



Table of Contents

Selection Procedure	49
Cooling Capacity Selection	49
Heating Capacity Selection	51
Evaporative Condensing Rooftop	54
Total Energy Recovery Wheel	54
Hot Gas Reheat Selection	55
Model Number Description	56
General Data	59
Performance Adjustment Factors	63
Performance Data	65
Gross Cooling Capacities	65
Supply Fan (with or without Variable Frequency Drive)	111
Exhaust Fan (with or without Energy Recovery Wheel)	113
Return Fan (with or without Energy Recovery Wheel)	114
Heating Capacities	116
Component Static Pressure Drops	120
Fan Drive Selections	127
Electrical Data	129
Electrical Service Sizing	129
Dimensional Data	133
Water Connection Locations	142
Electrical Entry Details	143
Minimum Required Clearance	143
Optional Roof Curb	144
Sensors	149
Weights	152

Mechanical Specifications	155
General	155
Casing	155
Access Doors	155
Blank Sections	155
Two- or Three-Piece Construction	155
Airflow Path	156
Burglar Bars	156
Belt Guard	156
Refrigeration System	156
Air-Cooled Condensing	157
Evaporative Condensing	157
Controls	158
Control Options	159
System Control Options	160
Electrical System	161
Filters	161
Exhaust Air	163
Return Air	164
Outside Air	165
Heating System	167
Energy Saving Options	167
Accessories	168
Trane Startup	169
Certified AHRI Performance	171

Features & Benefits

Figure 1. IntelliPak features

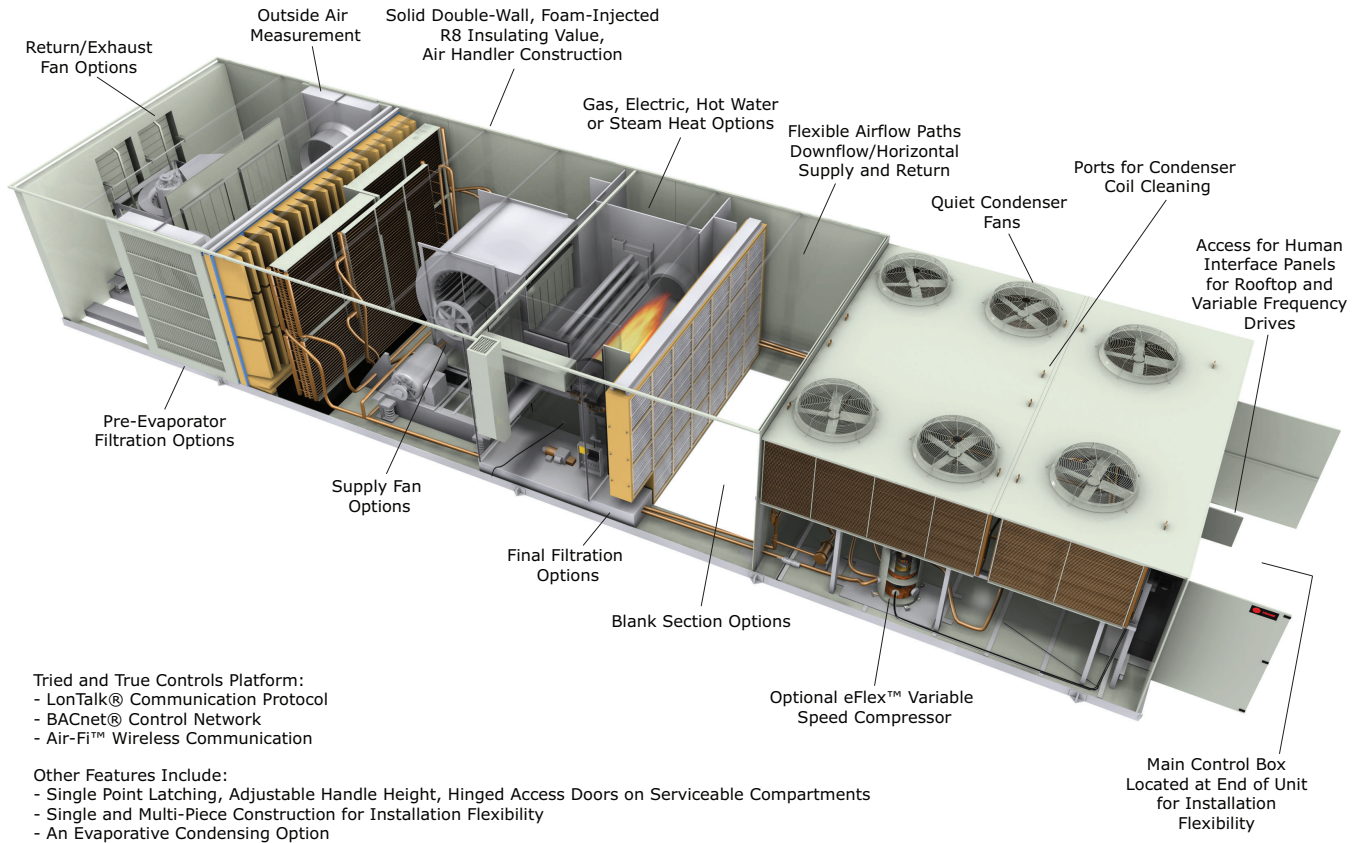
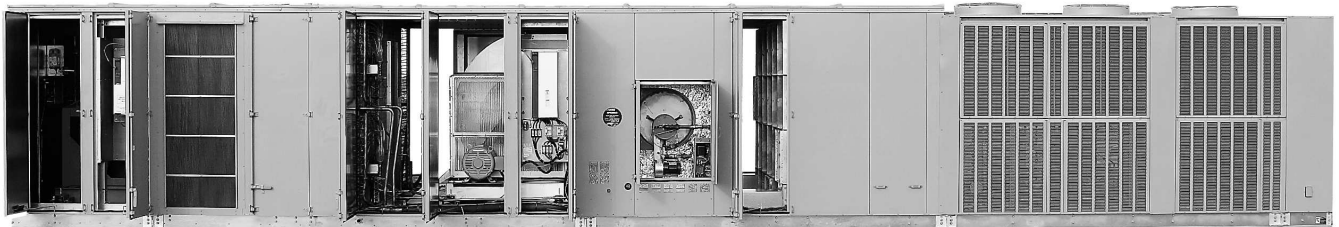

Figure 2. Standard unit with 8 ft blank space—panels removed



Standard Features

Figure 3. Human Interface panel



Figure 4. Solid double wall



Figure 5. Latching access door



Figure 6. Spring isolation



- 90 to 162 ton industrial/ commercial packaged rooftops
- R-410A HFC Refrigerant
- ASHRAE 90.1 - 2016 Efficiency Compliant
- IBC (International Building Code) Seismic compliance in select configurations
- cULus approval on standard options
- OSHPD Seismic compliance in select configurations

Controls

- Fully integrated, factory installed/commissioned microelectronic controls
- Unit mounted Human Interface Panel with a 2 line x 40 character English display and a 16 function keypad that includes custom, diagnostics, and service test mode menu keys
- Low charge indication and lockout Superheat monitoring and indication on each circuit
- CV, VAV, or SZVAV control
- Daytime warm-up (Occupied mode) on VAV models and morning warm-up operation on all units with heating options
- Low ambient compressor lockout control on units with economizers
- Froststat coil frost protection on all units
- Supply air static over-pressurization protection on units with VFD's
- Supply airflow proving Exhaust/return airflow proving on units with exhaust or return fan options
- Supply air tempering control
- Supply air heating control on SZVAV and VAV units with heat: modulating gas, electric, steam and hot water
- Emergency stop input
- Mappable sensors and setpoint sources
- Occupied/unoccupied switching
- Timed override activation

Refrigeration

- Trane 3-D scroll compressors
- Compressor lead/lag for run- time equalization¹
- Intertwined evaporator coil circuiting for full face area operation at part load conditions

¹. Not available with eFlex™ Variable Speed option



Features & Benefits

- Discharge service valve

Cabinet

- Solid double wall construction with foam injected R8 insulation throughout air handler section
- Single point latching, hinged access doors on control panel, filter, supply and exhaust/return fan section as well as gas heat section
- Flexible downflow and horizontal discharge/return paths
- Double sloped galvanized drain pans
- Extended casing, cooling only models
- Pitched roof over air handler section
- Heavy-gauge, continuous construction base rails
- Meets salt spray testing in accordance to ASTM B117 Standard

Mechanical

- Airfoil supply fan—standard and low CFM
- Totally enclosed condenser fan motors (TEFC)
- Stainless steel flue stack on gas heat units
- Two-inch spring fan isolation standard
- Two-inch MERV 8 high efficiency throwaway filters

Optional Features

Figure 7. Variable frequency drive



Figure 8. Traq damper



Figure 9. Convenience outlet

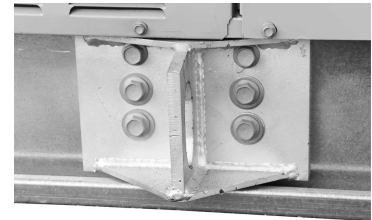

Controls

- Demand control ventilation (energy saving CO₂ economizer control)
- Twinning of up to four units for applications on common supply and return ducts
- Variable frequency drive (VFD) control of supply/exhaust/return fan motor
- High duct temperature thermostats
- Low ambient control to 0°F
- LonTalk Communication Interface module
- BACnet® Communication Interface module
- AirFi™ Wireless Comm Interface
- Rapid Restart
- Five ventilation override sequences
- Generic BAS interfaces—0-5 VDC and 0-10 VDC
- Remote Human Interface Panel (controls up to 4 units)
- SZVAV - Modulated Supply Fan for more efficient operation

- Rapid Restart - 100% cooling mode after power loss
- Fault Detection and Diagnostics (FDD)
- Supply & exhaust fan speed feedback through BCI-I

Refrigeration

- High capacity evaporator coils
- eFlex™ variable speed compressor
- Hot gas bypass to the evaporator inlet
- Suction service valves
- Modulating hot gas reheat
- Replaceable core filter driers

Cabinet

- Blank section options
 - Four foot blank—cooling only
 - Eight foot blank—cooling and heating
- Two or three-piece construction
- Single point access doors on both sides of the unit
- Double sloped stainless steel drain pans
- Belt guards for supply and exhaust/return fans
- Burglar bars on select configured units

Mechanical

- Modulating hot gas reheat
- Evaporative condensers
- Total energy recovery wheels rated in accordance to ARI Standard 1060
- Airfoil plenum return fan—standard and low CFM
- Forward curved exhaust fan—standard and low CFM
- Statitrac™ direct space sensing building pressurization control
- Outside air CFM compensation on SZVAV and VAV units with VFD and economizer
- Trane air quality (TraQ™) outside air measurement damper system
- 0-100% modulating outside air economizer
- 0-25% motorized outside air damper
- Low Leak, Standard Ultra Low Leak, and Ultra Low Leak AMCA 1A Economizer dampers

Filtration

- Pre-evaporator coil filter options
- Filter rack only (no filters)
- Two-inch throwaway filters, MERV8
- 90-95% bag filters, MERV15
- 90-95% cartridge filters, MERV14
- Final filters
 - Bag filters, MERV15
 - Standard and high temperature cartridge filters, MERV14
 - Standard and high temperature HEPA filters, MERV17

Heat Options

- Electric, gas, steam or hot water
- Gas heat options:
 - 10:1 modulating gas heat 850 MBh
 - 20:1 modulating gas heat 1100, 1800, and 2500 MBh
 - 10 year limited warranty on modulating gas heat



Features & Benefits

Electrical

- High Fault SCCR with unit interrupt rating of 65,000 amp (480V) and 25,000 amp (600V)
- Totally enclosed fan-cooled supply and exhaust/return fan motors
- Supply and exhaust/return motors with Internal Shaft Grounding Ring for VFD applications
- EISA-rated supply and exhaust/return fan motors as standard (60 Hz)
- Marine lights in serviceable compartments
- Electrical convenience outlet
- Through the door non-fused disconnect with external handle

Field Installed Accessories

- Roof curbs
- AirFi™ Wireless zone sensor
- AirFi™ Wireless Communication Interface
- Programmable sensors with night setback—CV and VAV
- Sensors without night setback— CV and VAV
- Remote zone sensors—used for remote sensing with remote panels
- ICS zone sensors used with Tracer system for zone control
- Outdoor temperature sensor for units without economizers
- Remote minimum position control for economizer
- Module kits available for field upgrade of controls

Features Summary

The IntelliPak 2 packaged rooftop air conditioner features a simplified installation process, more direct access to service ports and an extremely reliable system with multiple options to suit building requirements.

Installation and Service

- Loss of refrigerant charge diagnostics warns of a slightly undercharged situation followed by a warning and a lock out of an undercharged circuit for overall unit performance and compressor protection
- Superheat reading for each circuit displayed at the Human Interface panel to assist the service technician in troubleshooting
- Microprocessor unit controls coordinate the operation of the rooftop with quality, industry-accepted components for service ease
- Controls are factory installed/commissioned for ease of start up
- Condenser coil cleaning ports conveniently located on the roof of the condenser for efficient servicing
- Full unit points access—no field wiring of required points
- Modularity of unit control design
- Individual replaceable functional boards
- Unit mounted Human Interface Panel standard
 - User-friendly keypad edit parameters
 - Dedicated Human Interface access panel
 - Start up adjustments
 - Advanced diagnostics
- Unit-mounted and remote interface panel key pads are identical
- Single twisted wire pair communication for ICS interface
- Sturdy, double wall, foam injected, hinged access doors with height adjustable single point latches on main compartments for service ease
- Main control box conveniently located on end of unit for layout flexibility in tight spaces
- Built-in, optional features like high withstand rated breakers, belt guards and burglar bars contribute to safety
- Convenience outlet and marine lights for enhanced service capability
- Unit-mounted lifting lugs facilitate installation and can be used as unit tie-down points

Reliability

- Advanced diagnostics
- Microprocessor controls
- Built-in safeties
- Modular control design
- cULus approval as standard
- Corrosion protected condenser coil provides durability and defense against the destructive effects of alkalis, acids, alcohols, petroleum, seawater, salt air, and corrosive environments
- Internal Shaft Grounding Ring for motor bearing protection
- High fault unit interrupt rating (Short Circuit Current Rating-SCCR) up to 65k
- Factory-balanced supply, exhaust, and return fans
- Fully insulated floor, roof, panels, and gasketed interfaces reduce ambient air infiltration
- 200,000 average life fan bearings enhance unit durability
- Gas heater with free-floating stainless steel heat exchanger relieves the stresses of expansion and contraction. Stainless steel provides corrosion resistance through the entire material thickness
- Factory-wired and commissioned controls assure efficient and reliable rooftop operation
- Scroll compressors are designed to meet demanding operating conditions both in efficiency and reliability
- Roll-formed construction enhances cabinet integrity and assures a leak-proof casing
- AMCA 1A Ultra Low Leak economizer, including linkages and actuators, have a 5 year limited warranty and functional life of 60,000 opening and closed cycles
- Three-phase, direct-drive totally enclosed condenser fan motors enhance dependability and increase rooftop life

Application Flexibility

- Low CFM fans for low leaving air temperature applications
- Multiple downflow and horizontal air path options
- An array of heating options are available, including electric, natural gas, steam and hot water. The gas heating option provides a choice of two-stage gas heat, as well as full modulating gas heat. Electric heating options provide four to six steps of capacity.
- Variable speed compressors are designed to modulate refrigerant flow achieving outstanding partial load ratings (IEER)
- AMCA 1A Ultra Low Leak Economizer includes Fault Detection Diagnostics (FDD) to signal the IntelliPak controls for economizer faults
- Indoor Air Quality (IAQ)
 - Traq™ Damper System for precise outside air measurement
 - Demand Control Ventilation for CO₂ economizer control
 - Compensated outdoor air control
 - Statitrac™ direct space building pressure control
 - Multiple factory installed filter types, pre evaporator and final filters
 - Humidification control output
 - Comparative enthalpy, reference enthalpy, or dry bulb control for economizers
 - Supply, exhaust, & return fan size options to meet specific application needs
 - Exhaust or return fan options available for building pressure control
 - Low ambient cooling available to 0°F
- Superior building automation interface through LonTalk®
- Superior building automation interface through BACnet®
- Generic BAS interfaces
- Unit mounted or Remote Human Interface panels
- All parameters are editable from the Human Interface Panel
- Five factory preset ventilation override sequences which can be redefined in the field
- Variable Frequency Drives (VFD) included with or without bypass control for supply and exhaust/return fans
- Constant Volume (CV) controls stage both compressors and heat based on space requirements

Microchannel Condenser Coil

Microchannel condensing coils are all-aluminum coils with fully-brazed construction. This design reduces risk of leaks and provides increased coil rigidity — making them more rugged on the jobsite. Their flat streamlined tubes with small ports and metallurgical tube-to-fin bond allow for exceptional heat transfer. Microchannel all-aluminum construction provides several additional benefits:

- Light weight (simplifies coil handling)
- Easy to recycle
- Minimize galvanic corrosion

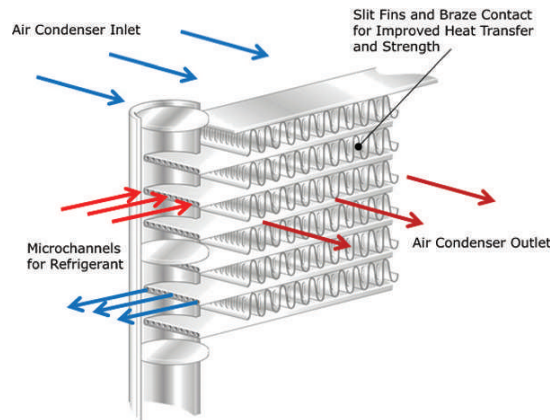

Energy Savings, Improved IAQ and Comfort

IntelliPak offers several ways to save energy while improving indoor air quality (IAQ) and zone comfort. Standard factory installed options for energy savings include, but are not limited to, modulating hot gas reheat, eDrive™ Direct Drive Plenum Supply Fans and eFlex™ variable speed compressors.

Single Zone VAV (SZVAV)

Single Zone VAV (SZVAV) is designed for use in single zone applications such as gymnasiums, auditoriums, manufacturing facilities, retail box stores, and any large open spaces where there is a diversity in the load profile. It is an ideal replacement to "yesterday's" constant-volume (CV) systems, as it reduces operating costs while improving occupant comfort.

SZVAV systems combine Trane application, control and system integration knowledge to exactly match fan speed with cooling and heating loads, regardless of the operating condition. Trane algorithms meet and/or exceed ASHRAE 90.1 SZVAV energy-saving recommendations and those of CA Title 24. The result is an optimized balance between zone temperature control and system energy savings. Depending on your specific application, energy savings can be as much as 20+%.

Note: *Building system modeling in energy simulation software such as TRACE is recommended to evaluate performance improvements for your application.*

SZVAV is fully integrated into the control system. It provides the simplest and fastest commissioning in the industry through proven factory-installed, wired, and tested system controllers. All control modules, logic boards and sensors are factory installed and tested to ensure the highest quality and most reliable system available. This means no special programming of algorithms, or hunting at the jobsite for field installed sensors, boards, etc. SZVAV is a quick and simple solution for many applications and is available from your most trusted rooftop VAV system solution provider -Trane.

Ultra Low Leak, AMCA 1A Economizer Damper

The pre-engineered design special Ultra Low Leak AMCA 1A Economizer Damper package will meet or exceed requirements of California Title 24, ASHRAE 90.1, and IECC. The economizer,

including linkages and actuators, will have a 5 year limited warranty and functional life of 60,000 opening and closed cycles.

Dampers are AMCA 511 Class 1A certified with a maximum leakage rate of 3 CFM/sq-ft at 1.0 in. WC pressure differential. As part of this package, Fault Detection and Diagnostics (FDD) control is included to meet California requirements. FDD control monitors the commanded position of the economizer compared to the feedback position of the damper. If the damper position is outside of $\pm 10\%$ of the commanded position, a diagnostic is generated.

Trane® Air Quality (TraQ™) Outside Air Measurement System

Trane® Air Quality (TraQ™) outside air measurement system uses velocity pressure sensing rings to measure airflow in the outside air opening from 40 cfm/ton to maximum airflow. TraQ™ dampers are AMCA certified ($\pm 5.0\%$) from 300fpm to 2500fpm, meeting requirements of LEED IE Q Credit 1.

eFlex™ Variable Speed Scroll Compressor

Trane® eFlex™ variable speed scroll compressors are matched with a specially designed variable frequency drive that allows a modulating ratio of up to 4:1. Our eFlex™ compressors are paired with fixed speed compressors such that the units are capable of continuous capacity modulation from 15 to 100%. By design, unit capacity stages overlap to eliminate the frequent cycling between stages typical of competing designs. This allows for unmatched control of leaving air temperatures to meet space loads. The eFlex™ compressors also include brushless permanent magnet motors designed to operate at higher efficiency along with reducing the compressor motor speed and staging results in significant part load energy savings. This makes units with eFlex™ compressors the most efficient products in their class at part load.

Energy Recovery Wheel

Because the energy recovery wheel has the capability to hold and transfer sensible and latent energy, this option can significantly reduce HVAC system operating energy costs. IntelliPak 2 offers the total energy wheel option to recover energy from the building exhaust. Benefits of the total energy recovery feature include:

- Energy efficient ventilation to reduce operating costs
- The ability to increase ventilation, allowing for improved indoor air quality (IAQ)
- High efficiency, which permits increased outdoor air quantity without increasing heating or cooling

Figure 10. Energy recovery wheel in economizer mode

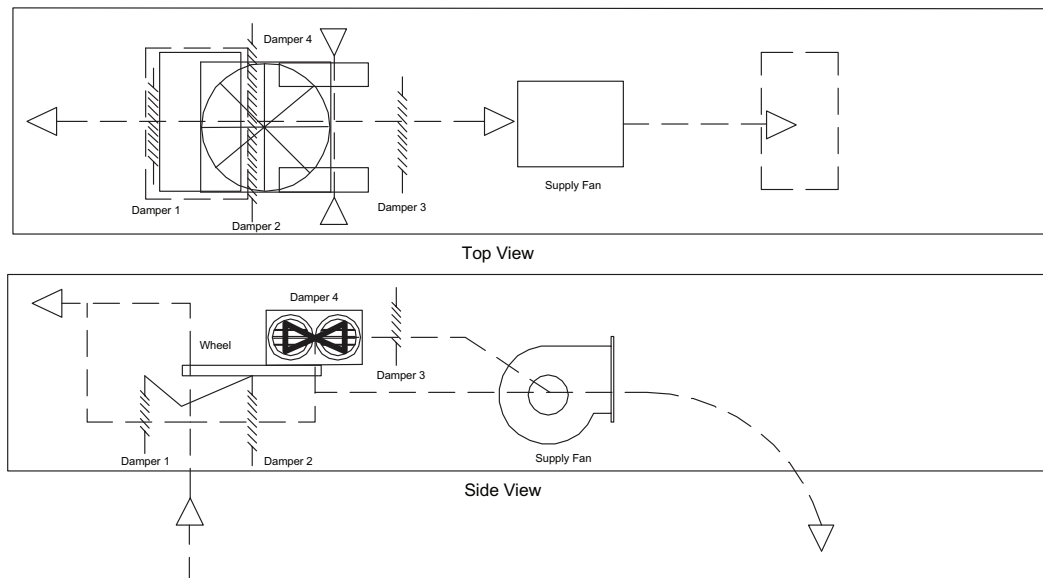

Modulating Hot Gas Reheat

By its very nature, the colder the air, the less moisture it contains. With hot gas reheat, hot refrigerant gas leaving the compressor is diverted to a hot gas reheat coil. The cold air leaving the DX coil is then reheated to an acceptable temperature and returned as dehumidified air to the facility space. The modulation of the hot gas reheat helps maintain both temperature and humidity levels in cooling mode, while reducing unit operating costs and saving energy.

Figure 11. Hot gas reheat

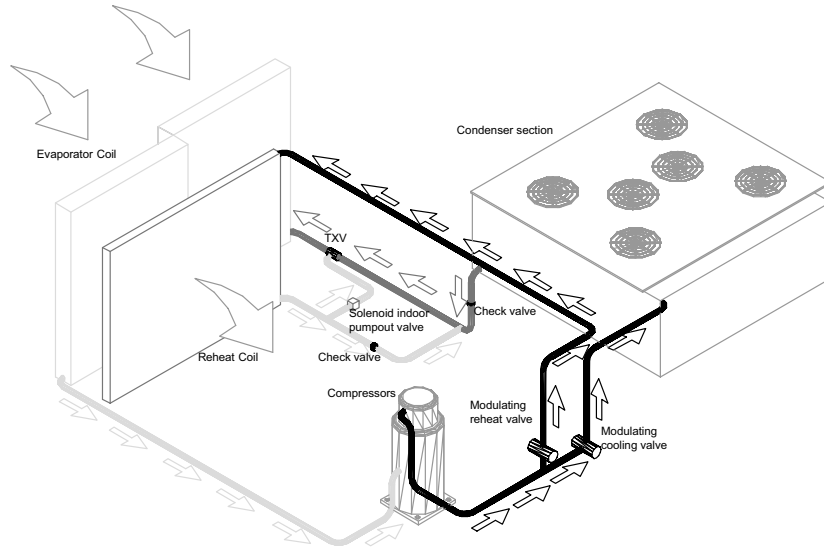

Evaporative Condensing Units

Unlike air-cooled condensers, evaporative condensers are dependent on the ambient wet bulb, rather than dry bulb, temperature. Wet bulb temperature is generally several degrees lower than dry bulb. Utilizing the lower wet bulb temperature to condense refrigerant vapor can dramatically decrease compressor power consumption by reducing compressor discharge pressure, thereby increasing unit efficiency.

Figure 12. Unit top/left side view—evaporator-cooled condenser

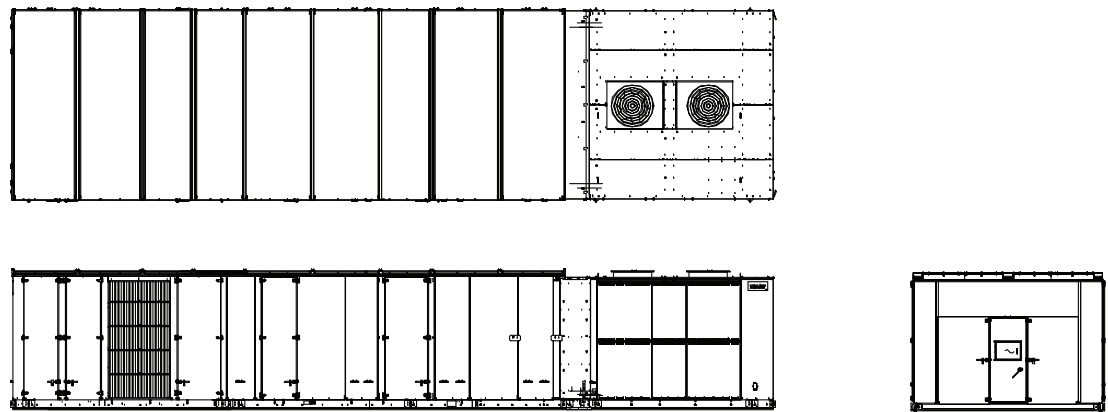

Integrated Rooftop Systems: Profitable, Simple

Trane® integrated rooftop systems make design and installation of building management systems cost effective and easy. Trane offers three choices for building management controls: Tracer® building automation system with a Trane® Control Interface (TCI), LonTalk® Communication Interface (LCI) or Tracer® SC with BACnet® Communication Interface (BCI).

The Tracer Integrated Comfort™ System (ICS) or System Controller (SC) improves job profit and increases job control by combining Trane rooftop units with the Trane Tracer building management system. These integrated systems provide total building comfort and control. Some of the primary motivations for building owners/managers in deciding to purchase a HVAC controls system are energy savings, cost control, and the convenience of facility automation.

Integrated Comfort with LonTalk Communication

Trane® Tracer® LonTalk™ Control Interface (LCI) for IntelliPak offers a building automation control system with outstanding interoperability benefits.

LonTalk, which is an industry standard, is an open, secure and reliable network communication protocol for controls, created by Echelon Corporation and adopted by the LonMark® Interoperability Association. It has been adopted by several standards, such as: EIA-709.1, the Electronic Industries Alliance (EIA) Control Network Protocol Specification and ANSI/ASHRAE 135, part of the American Society of Heating, Refrigeration, and Air Conditioning Engineer's BACnet® control standard for buildings.

Interoperability allows application or project engineers to specify the best products of a given type, rather than one individual supplier's entire system. It reduces product training and installation costs by standardizing communications across products. Interoperable systems allow building managers to monitor and control IntelliPak equipment with a Trane Tracer Summit or a 3rd party building automation system. It enables integration with many different building controls such as access/intrusion monitoring, lighting, fire and smoke devices, energy management, and a wide variety of sensors (temperature, pressure, light, humidity, occupancy, CO₂ and air velocity). For more information on LonMark, visit www.lonmark.org or Echelon, www.echelon.com.

Integrated Comfort with BACnet Communication

The Trane SC BACnet Control Interface (BCI-I) for IntelliPak offers a building automation control system with outstanding interoperability benefits. BACnet, which is an industry standard, is an open, secure and reliable network communication protocol for controls, created by American Society of Heating, refrigerating and Air-Conditioning Engineers, Inc. (ASHRAE)

Interoperability allows application or project engineers to specify the best products of a given type, rather than one individual supplier's entire system. It reduces product training and installation costs by standardizing communications across products. Interoperable systems allow building managers to monitor and control IntelliPak equipment with Tracer SC or a 3rd party building automation system. It enables integration with many different building controls such as access/intrusion monitoring, lighting, fire and smoke devices, energy management, and a wide variety of sensors (temperature, pressure, light, humidity, occupancy, CO₂ and air velocity).

Diagnostic Points	Control Points	Setup and Configuration
All self-contained unit diagnostics	• Cooling and heating setpoints	• Supply fan mode
System setpoints	• Zone setpoint offsets	• Configuration of supply air reset
System sensor inputs	• VAV discharge air setpoints	• Ventilation override mode configuration
Supply fan mode and status	• Supply air pressure setpoint	• Default system setpoint values
VFD speed	• Space pressure setpoint	• Sensor calibration offsets
• Unit heat/cool mode	• Zone and outdoor temperature values	
• Economizer position & setpoints	• Cooling and heating enable/disable	
• On/off status of each compressor	• Economizer enable/disable	
• Evaporator and saturated condenser temps	• Economizer setpoint	
• Hydronic heat valve position	• Economizer minimum position	
• Electric heat stage status	• Activation of ventilation override modes	
• Ventilation override mode status	• Diagnostics reset	



Features & Benefits

Diagnostic Points	Control Points	Setup and Configuration
	<ul style="list-style-type: none"> • Unit priority shutdown 	
	<ul style="list-style-type: none"> • Timed override activation 	

Trane Air-Fi™ Wireless Communication

Trane Air-Fi™ Wireless replaces the need for wired building controls, allowing installations to be completed quickly with less disruption to occupants in existing buildings, while also providing greater reliability, simplified installation and more flexibility as building spaces change. Many building owners face challenges connected to maintenance and repair with traditional wired systems, which fail when wires are cut or disconnected or fail intermittently when damaged. Air-Fi Wireless can help optimize any building's performance with less risk, thanks to self-repairing mesh technology that features redundant signal paths to help prevent communication failures.

Trane offers a typical 200-foot indoor signal range, with up to four times the number of paths, extending up to half-mile when unobstructed for even greater levels of signal reliability. With a battery life that's three times what competitors offer, the lifetime battery² eliminates the need to replace batteries over the life of the system in most installations and saves time and money. Air-Fi Wireless is a ZigBee® Certified Building Automation solution, and the system is built on a platform that supports BACnet™ open standards. This allows customers to integrate devices in the future when the building expands or changes. Wireless sensors are easy to move or replace, as needed, to resolve issues related to sensing accuracy, aesthetics or reconfigured spaces.

Trane Air-Fi Wireless also conforms to the IEEE 802.15.4 standard, so customers get a wireless BAS communication system that reliably coexists with other wireless systems, including Bluetooth® and Wi-Fi™ — without interference. There's no security risk with Air-Fi Wireless, which uses a separate, secure network from those used by a building's IT system. Air-Fi Wireless secures building automation networks by the use of AES-128 encryption, keys and device authentication.

The Trane Air-Fi Wireless interface is available factory-installed and addressed as a design special to expedite installation and reduce labor and upfront costs. It also ensures higher installation quality that results in better building performance for customers because the work is done in a controlled environment, making it more repeatable and consistent. To learn more about Trane Air-Fi Wireless technology, visit <http://commercial.trane.com/content/trane-lp/airfi.html>.

Optimum Building Comfort Control

The modular control design of the UCM allows for greater application flexibility. Customers can order exactly the options required for the job, rather than one large control package. Unit features are distributed among multiple field replaceable printed circuit boards. The Trane UCM can be setup to operate under one of three control applications:

- Standalone
- Interface with Trane Tracer building management system
- Interface with a generic (non-Trane) building management system. All setup parameters are preset from the factory, requiring less start-up time during installation

The unit mounted Human Interface and the Remote Human Interface Panels allow for less time spent servicing due to easy to read diagnostics and control adjustments made off of the roof.

All rooftop control parameters are adjustable and can be setup through the Remote Human Interface Panel such as, but not limited to: system on/off, demand limiting type, night setback setpoints, and many other setpoints. No potentiometers are required for setpoint adjustment; all adjustments are done through the Remote Human Interface keypad.

Up to 56 different rooftop diagnostic points can be monitored through the human interfaces such as: sensor failures, loss of supply airflow, and compressor trip. No special tools are required for servicing the unit. All diagnostic displays are available at the Remote Human Interface and will be held in memory, so that the operator/service person can diagnose the root cause of failures.

² Based on typical indoor operating conditions.

Statitrac Direct Space Building Pressurization Control

Figure 13. Statitrac

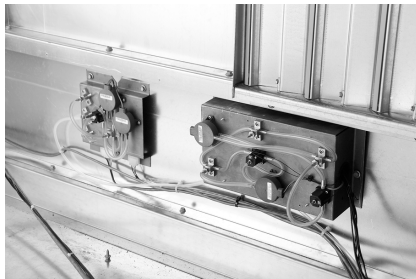

Trane Statitrac control is a highly accurate and efficient method of maintaining building pressure control with a large rooftop air conditioner.

Building space pressurization control is achieved with a 100 percent modulating exhaust system that features a single forward curved fan, with modulating discharge dampers that operates only when needed or a 100% modulating plenum return fan with airfoil wheel that operates continuously with the supply fan. Most of the operating hours of the 100 percent modulating exhaust system are at part load, resulting in energy savings. Statitrac, with the 100 percent modulating exhaust system, provides comfort and economy for buildings with large rooftop air conditioning systems.

Statitrac control with fan is simple! The space pressure control turns the fans on and off as required and modulates dampers, or fan speed, to maintain space pressure within the space pressure deadband.

The unit mounted can be used to:

- Adjust space pressure setpoint
- Adjust space pressure deadband
- Measure and read building static pressure

The modulating system maintains the desired building pressure, while saving energy and keeping the building at the right pressure. Proper building pressurization eliminates annoying door whistling, doors standing open, and odors from other zones. The Statitrac direct space building control sequence will also be maintained when a variable frequency drive is used.

Statitrac Control with Plenum Return Fan

Other manufacturers utilize a fan tracking control scheme whereby the return fan speed tracks the supply fan speed in a linear fashion. This scheme works well at minimum and maximum CFM airflow. However, due to the dissimilar performance characteristics of the supply and return fan, building pressure is difficult to control at points between minimum and maximum CFM airflow.

The Trane return fan/building pressurization control system eliminates the effects of dissimilar supply/return fan characteristics experienced in a linear tracking control system by modulating the exhaust dampers based on space pressure, the return/economizer dampers based on ventilation requirements, and the return fan speed based on return plenum static pressure. The supply fan, return fan, exhaust damper, and return/economizer damper systems act independently from one another to maintain comfort and building pressure.

The return fan operates whenever the supply fan is in operation. The unit exhaust dampers are modulated in response to the space pressure signal to maintain space pressure within the space pressure deadband. The unit economizer and return air dampers are modulated based on ventilation control, minimum outside air economizer position, and economizer cooling request. The return fan speed is modulated based on a return duct static pressure deadband control.

Using the unit mounted Human Interface, the operator can:

- Adjust space pressure setpoint
- Adjust space pressure deadband
- Measure and read building space pressure
- Measure and read return duct static pressure.



Features & Benefits

Proper building pressurization eliminates annoying door whistling, doors standing open, and odors from other zones.

Variable Frequency Drives (VFD)

Variable Frequency Drives are factory installed and tested to provide supply/exhaust/return fan motor speed modulation. VFD's, as compared to discharge dampers, are quieter, more efficient, and may be eligible for utility rebates. The VFD's are available with or without a bypass option. Bypass control will simply provide full nominal airflow in the event of drive failure. Further motor reliability is added with the optional Internal Shaft Grounding Ring.

3-D Scroll Compressors

The Trane 3-D® Scroll provides important reliability and efficiency benefits inherent to its design. The 3-D Scroll allows the orbiting scrolls to touch in all three dimensions forming a completely enclosed compression chamber which leads to increased efficiency.

In addition, the orbiting scrolls only touch with enough force to create a seal, thereby resulting in no wear between the scroll involutes. The fixed and orbiting scrolls are made of high strength cast iron, which results in less thermal distortion and minimal leakage. In addition, better part isolation has resulted in reduced compressor sound levels compared to previous designs.

Features listed below optimize the compressor design and performance:

- Optimized scroll profile
- Heat shield protection to reduce heat transfer between discharge and suction gas
- Suction Gas Cooled Motor
- Low Torque Variation
- Improved sealing between condenser side and air handler side

Additional features are incorporated in the compressor design for greater compressor reliability:

- Patented design motor cap for improved motor cooling
- Improved bearing alignment
- Improved resistance to dry start up
- Oil sight glass for evaluating proper oil levels

Rapid Restart

Trane understands that every second counts. Trane equipment, controls, and control sequences are designed to get the system back online and properly functioning should the facility experience a power cycle event.

- Trane HVAC system design is optimized for fast restart.
- IntelliPak Rooftop System controls and equipment provide an integrated, pre-engineered solution for fast restart.
- Proven operational procedures maximize uptime outside of critical outages and get the system up and running as quickly as possible.

With Rapid Restart and use of a backup generator, the IntelliPak™ Rooftop System can provide full cooling in 120 seconds or less after regaining electrical power. This option is fully integrated into the IntelliPak controls logic via standard human interface. Rapid Restart is a perfect fit in time-sensitive applications where extended down time is not an option and heating/cooling is crucial.

Figure 14. Rapid Restart

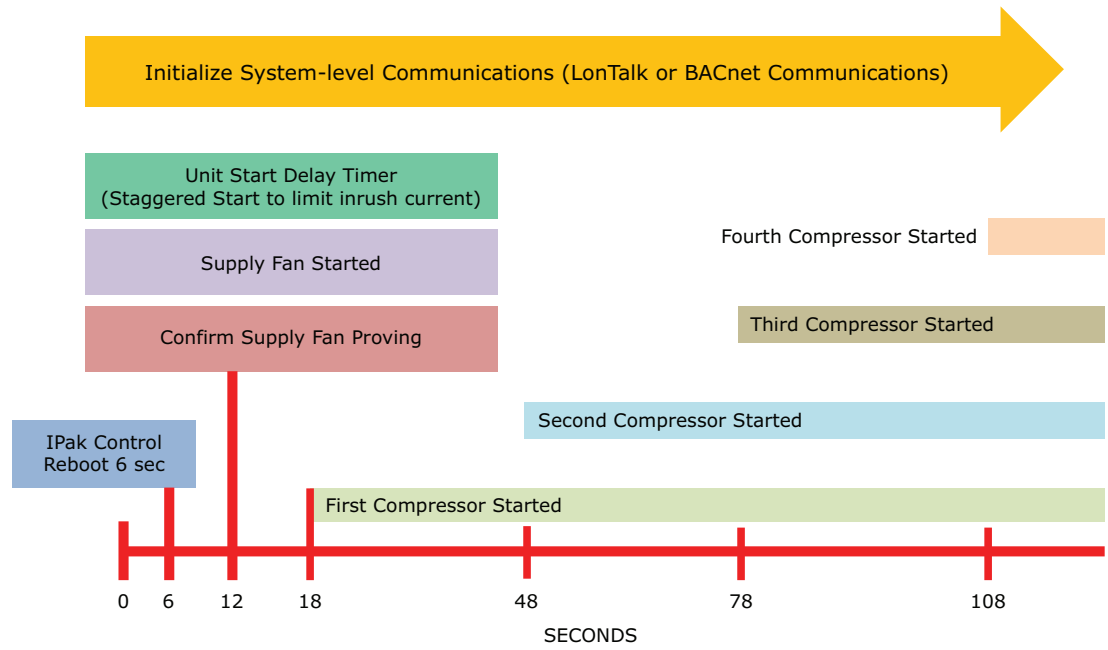

Controls

Figure 15. IntelliPak 2 control panel

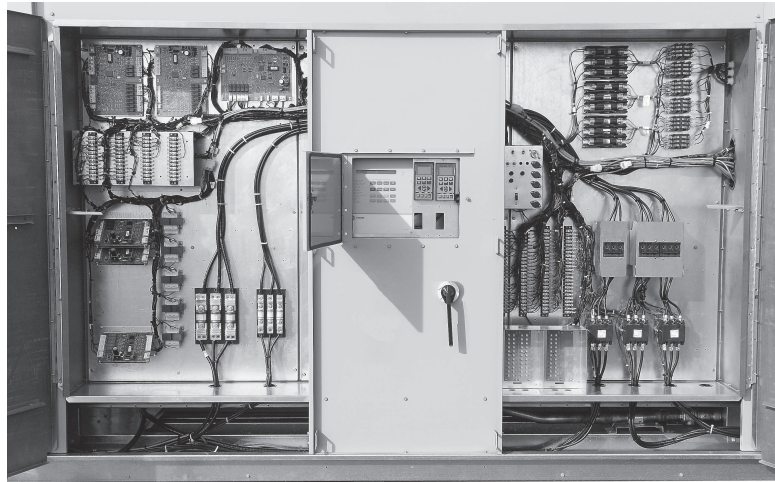

Variable Air Volume (VAV) Only

Note: When noted in this sequence “Human Interface Panel,” the reference is to both the unit mounted and remote mounted Human Interface Panel. All setpoint adjustments can be accomplished at the unit or Remote Human Interface Panel.

Supply Air Pressure Control

Variable Frequency Drive (VFD) Control

A pressure transducer measures duct static pressure, and the VFD is modulated to maintain the supply air static pressure within an adjustable user-defined range. The range is determined by the supply air pressure setpoint and supply air pressure deadband, which are set through the or BAS/Network.

The variable frequency drives provide supply fan motor speed modulation. The drive will accelerate or decelerate as required to maintain the supply static pressure setpoint.

Supply Air Static Pressure Limit

The opening of VAV terminals, and the amount of supply air provided by the variable frequency drive are coordinated during start up and transition to/from Occupied/Unoccupied modes to prevent over pressurization of the supply air ductwork. However, if for any reason the supply air pressure exceeds the user-defined supply air static pressure limit that was set at the , the supply fan and VFD are shut down. The unit is then allowed to restart three times. If the over pressurization condition occurs on the third restart, the unit is shut down and a manual reset diagnostic is set and displayed at the and BAS/Network.

Supply Air Temperature Controls

Cooling/Economizer

During Occupied cooling mode of operation, the economizer (if available) and mechanical cooling are used to control the supply air temperature. The supply air temperature setpoint and deadband are user-defined at the Human Interface Panel. The supply air temperature setpoint may be user-defined from the BAS/Network. If the conditions of the outside air are appropriate to use “free cooling,” the economizer will be used first in an attempt to satisfy the supply air setpoint; then, if required, the mechanical cooling will be staged on to maintain supply air temperature setpoint. Minimum On/Off timing of the mechanical cooling prevents rapid cycling.

On units with economizer, a call for cooling will modulate the outside air dampers open. The rate of economizer modulation is based on deviation of the supply air temperature from setpoint, i.e., the further away from setpoint, the faster the outside air damper will open. First stage of cooling will be allowed to start after the economizer reaches full open.

The economizer is only allowed to function freely if one of the following conditions is met:

- For dry bulb economizer control the ambient temperature must be below the dry bulb temperature control setting.
- For reference enthalpy economizer control, outdoor air enthalpy must be below the enthalpy control setting. At outdoor air conditions above the enthalpy control setting, mechanical cooling only is used and the outside air dampers remain at minimum position.
- For comparative enthalpy economizer control, outdoor air enthalpy must be below the enthalpy of the return air.

If the unit does not include an economizer, mechanical cooling only is used to satisfy cooling requirements. The outdoor air dampers may be set for a maximum of 25% outdoor air, through the unit mounted Human Interface Panel or a signal from the BAS/network, if the rooftop is equipped with 0 to 25% motorized outside air dampers.

Heating

Modulating Gas

Upon a call for heating, the HEAT module closes the heating contacts, beginning the firing sequence. First, the heat exchanger combustion blower begins operation. Upon positive proving of combustion airflow, a 60 second pre-purge cycle is executed. Then the ignition sequence takes place.

If ignition is not proven, the safety control locks out and must be manually reset. As long as there is a call for heat, the safety control can be reset, which starts another purge cycle and try for ignition.

Once ignited, as additional heat is required, the combustion air damper opens, increasing the firing rate.

During heating operation, an electronic flame safety control provides continuous flame supervision. If combustion should become unstable for any reason, heating will automatically shut down and be locked out until reset at the unit mounted Human Interface panel.

As the heating requirement is satisfied, the HEAT module will modulate the combustion air damper closed and the firing rate will lower to maintain the desired outlet temperature. When the requirement is fully satisfied, the heating contacts are opened, de-energizing the heat. The specific sequence of operation of the gas heat will depend on the size of the heat exchanger.

Electric Heating

The individual stages of electric heat will be sequenced on the zone demand. The number of available stages will depend on the unit size and heat capacity selected.

Hot Water or Steam

On units with hot water or steam heating, the supply air temperature can be controlled to a heating setpoint during the Occupied mode. The supply air temperature heating setpoint and deadband are user-defined at the Human Interface Panel. VAV Occupied heating on hot water and steam heat units is enabled by closing a field-supplied switch or On units with hot water or steam heating, the supply air temperature can be controlled to a heating setpoint during the Occupied mode. The supply air temperature heating setpoint and deadband are user-defined at the Human Interface Panel. VAV Occupied heating on hot water and steam heat units is enabled by closing a field-supplied switch or contacts connected to an changeover input on the RTM.

Supply Air Setpoint Reset

Figure 16. Supply air temperature reset

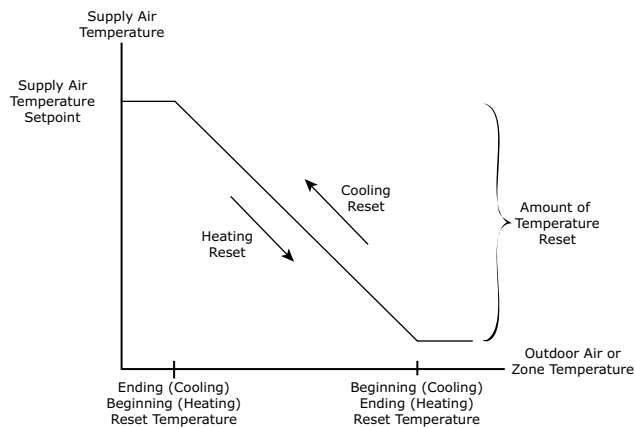

Supply air setpoint reset can be used to adjust the supply air temperature setpoint on the basis of a zone temperature or on outdoor air temperature. Supply air setpoint reset adjustment is available from the Human Interface Panel for supply air heating and supply air cooling control.

Outdoor air cooling reset

Outdoor air cooling reset is sometimes used in applications where the outdoor temperature has a large effect on building load. When the outside air temperature is low and the building cooling load is low, the supply air setpoint can be raised, thereby preventing sub-cooling of critical zones. This reset can lower usage of mechanical cooling, thus savings in compressor kW, but an increase in supply fan kW may occur.

Outdoor air heating reset

Outdoor air heating reset is the inverse of cooling, with the same principles applied. For both outdoor air cooling reset and heating reset, there are three user-defined parameters that are adjustable through the Human Interface Panel:

- Beginning reset temperature
- Ending reset temperature
- Amount of temperature reset

Zone reset

Zone reset is applied to the zone(s) in a building that tend to be overly cool or overly hot. The supply air temperature setpoint is adjusted based on the temperature of the critical zone(s). This can have the effect of improving comfort and/or lowering energy usage. The user-defined parameters are the same as for outdoor air reset.

Supply Air Tempering

Zone Temperature Control

Unoccupied Zone Heating and Cooling

During Unoccupied mode, the unit is operated as a CV unit. VFDs operate at 100% and VAV boxes are driven full open. The unit controls zone temperature within the Unoccupied zone cooling and heating (heating units only) setpoints.

Daytime Warm-up

This feature is available on all types of heating units. During Occupied mode, if the zone temperature falls to a preset, user-defined zone low limit temperature setpoint, the unit is put into Unoccupied mode and Daytime Warm-up is initiated. The system changes over to CV heating (full unit airflow), the VAV boxes are fully opened and full heating capacity is provided until the Daytime Warm-up setpoint is reached. The unit is then returned to normal Occupied mode.

Outside Air Measurement

Trane air quality (Traq™) outside air measurement damper system utilizes velocity pressure sensing rings. Based on unit design CFM, the ventilation control module (VCM) monitors and controls the quantity of outside air entering the unit. The outside airflow can be calibrated to accommodate for altitude. The following options are also available:

- An optional temperature sensor may be connected to the ventilation control module to enable it to control a field-installed pre-heater.
- An optional CO₂ sensor may be connected to the ventilation control module to control outside air based on CO₂ Demand Control Ventilation (DCV).

Unit Feedback – Supply and Exhaust Fan Speed Setpoints

BACnet® control network (BCI-I) points are available to allow for communication of the Supply and Exhaust Fan Speed Setpoints to the BAS. These points are only available for true VAV units. These setpoints will be overridden by equipment protection functionality, when applicable. These point additions eliminate the need to hard-wire directly to the VFDs for control.

Outside Air CFM Compensation

As the supply fan modulates, this function proportionally adjusts the economizer minimum position to compensate for the change in total airflow, in order to maintain a constant percent of outside air. The modified economizer minimum position is computed as a linear function, based on VFD position, given the two endpoints:

- Minimum Position with VFD @ 0%
- Minimum Position with VFD @ 100%

Both are user adjustable at the Human Interface Panel.

Single Zone Variable Air Volume (SZVAV) Only

The IntelliPak® controls platform will support Single Zone VAV as an optional unit control type in order to meet ASHRAE 90.1. The basic control will be a hybrid VAV/CV configured unit that provides discharge temperature control to a varying discharge air temperature target setpoint based on the space temperature and/or humidity conditions. Concurrently, the unit will control and optimize the supply fan speed to maintain the zone temperature to a zone temperature setpoint.

VFD Control

Single Zone VAV units will be equipped with a VFD-controlled supply fan which will be controlled via a 0-10 VDC signal from the Rooftop Module (RTM). With the RTM supply fan output energized and the RTM VFD output at 0 VDC, the fan speed output is 37% (22Hz) from the VFD by default; and at 10 VDC the fan speed output is 100% (60Hz). The control scales the 0-10 VDC VFD output from the RTM linearly to control between the 37-100% range.

The VFD will modulate the supply fan motor speed, accelerating or decelerating as required to maintain the zone temperature to the zone temperature setpoint. When subjected to high ambient return conditions the VFD will reduce its output frequency to maintain operation. Bypass control is offered to provide full nominal airflow in the event of drive failure.

Supply Fan Output Control

Units configured for Single Zone VAV control will utilize the same supply fan output control scheme as on traditional VAV units except the VFD signal will be based on zone heating and cooling demand instead of the supply air pressure.

Ventilation Control

Units configured for Single Zone VAV control will require special handling of the OA Damper Minimum Position control in order to compensate for the non-linearity of airflow associated with the variable supply fan speed and damper combinations. Units configured for Traq with or without DCV will operate identically to traditional units with no control changes.

Space Pressure Control

For units configured with Space Pressure Control with or without Statitrac, the new schemes implemented for economizer minimum position handling require changes to the existing Space Pressure Control scheme in order to prevent over/under pressurization. The overall scheme will remain very similar to VAV units with Space Pressure Control with the exception of the dynamic Exhaust Enable Setpoint.

For SZVAV an Exhaust Enable Setpoint must be selected during the 100% Fan Speed Command. Once selected, the difference between the Exhaust Enable Setpoint and Design OA Damper Minimum Position at 100% Fan Speed Command will be calculated. The difference calculated will be used as an offset and added to the Active Building Design OA Minimum Position Target in order to calculate the dynamic Exhaust Enable Target, which will be used throughout the Supply Fan Speed/OA Damper Position range.

The Exhaust Enable Target could be above or below the Active Building Design OA Minimum Position Target Setpoint, based on the Active Exhaust Enable Setpoint being set above or below the Building Design Minimum Position at 100% Fan Speed Command. Note that an Exhaust Enable Setpoint of 0% will result in the same effect on Exhaust Fan control as on VAV applications with and without Statitrac.

Occupied Cooling Operation

For normal cooling operation, cooling capacity will be staged or modulated in order to meet the calculated discharge air target setpoint. If the current active cooling capacity is controlling the discharge air within the deadband, no additional cooling capacity change will be requested. As the Discharge Air Temperature rises above the deadband, the algorithm will request additional capacity as required (additional compressors or economizer). As the Discharge Air Temperature falls below the deadband, the algorithm will request a reduction in active capacity.

Default Economizer Operation

By default, the unit will be setup to optimize the minimum supply fan speed capability during Economizer Only operation. If the economizer is able to meet the demand alone, due to desirable ambient conditions, the supply fan speed will be allowed to increase above the minimum prior to utilizing mechanical cooling if discharge air setpoint falls below the discharge air Lower Limit (Cooling) setpoint.

Unoccupied Mode

In Unoccupied periods the unit will utilize setback setpoints, 0% Minimum OA Damper position, and Auto Fan Mode operation as on normal Constant Volume units. The Supply Fan speed will be forced to 100% for all active heating and cooling requests in this mode.

Occupied Heating Operation

Occupied heating operation will utilize two separate control methodologies based on heating configurations. For all "Staged" Heating types, the unit will utilize full airflow during all active heating periods exactly like traditional Constant Volume units. For "Modulating" Heating types the unit will have the ability to utilize SZVAV Heating, much like Active Cooling, in order to maintain the Zone Temperature to the Zone Heating setpoint. Also, on units configured with a Modulating Heat type, the customer will have the ability to select between SZVAV Heating control, or to utilize traditional Constant Volume, full airflow heating based on the associated unit setup.

Compressor (DX) Cooling

Compressor control and protection schemes will function identical to that of a traditional unit. Normal compressor proving and disable input monitoring will remain in effect as well as normal three minute minimum on, off, and inter-stage timers. Also, all existing head pressure control schemes will be in effect.

Cooling Sequence

If the controller determines that there is a need for compressor stages in order to meet the calculated discharge air target setpoint, once supply fan proving has been made, the unit will begin to stage compressors accordingly.

Note: *The compressor staging order will be based on unit configuration and compressor lead/lag status.*

Once the discharge air target setpoint calculation has reached the user define Minimum Setpoint and compressors are being utilized to meet the demand, if the cooling demand increases, the discharge air target setpoint value will continue to lower past the minimum setpoint and begin to ramp the supply fan speed upward toward 100%.

Once the discharge air target setpoint calculation has reached the Minimum Setpoint and compressors are being utilized to meet the demand, as the discharge air target setpoint value continues to calculate lower the algorithm will begin to ramp the supply fan speed up toward 100%. Note that the supply fan speed will remain at the compressor stage's associated minimum value (as described below) until the discharge air target setpoint value is calculated below the discharge air temperature Minimum Setpoint (limited discharge air target setpoint).

As the cooling load in the zone decreases the zone cooling algorithm will reduce the speed of the fan down to minimum per compressor stage and control the compressors accordingly. As the compressors begin to de-energize, the supply fan speed will fall back to the Cooling Stage's associated minimum fan speed, but not below. As the load in the zone continues to drop, cooling capacity will be reduced in order to maintain the discharge air within the $\pm 1/2$ discharge air target deadband.

Constant Volume (CV) Only

Occupied Zone Temperature Control

Cooling/Economizer

During Occupied cooling mode, the economizer (if provided) and mechanical cooling are used to control zone temperature. The zone temperature cooling setpoint is user-defined at the Human Interface Panel or from the BAS/Network. If the conditions of outside air is appropriate to use "free cooling", the economizer will be first be used to attempt to satisfy the cooling zone temperature setpoint; then the compressors will be staged up as necessary. Minimum on/off timing of compressors prevents rapid cycling.

On units with economizer, a call for cooling will modulate the outside air dampers open. The rate of economizer modulation is based on deviation of the zone temperature from setpoint, i.e., the further away from setpoint, the faster the outside air damper will open. First stage of cooling will be allowed to start after the economizer reaches full open.

The economizer is only allowed to function freely if one of the following conditions is met:

- For dry bulb economizer control, the ambient temperature must be below the dry bulb temperature control setting.
- For reference enthalpy economizer control, outdoor air enthalpy must be below the enthalpy control setting. At outdoor air conditions above the enthalpy control setting, mechanical cooling only is used and the outdoor air dampers remain at minimum position.
- For comparative enthalpy economizer control, outdoor air enthalpy must be below the enthalpy of the return air.

If the unit does not include an economizer, mechanical cooling only is used to satisfy cooling requirements. The outdoor air dampers may be set for a maximum of 25% outdoor air, through the unit mounted Human Interface Panel or a signal from the BAS/network, if the rooftop is equipped with 0 to 25% motorized outside air dampers.

Heating

Gas Heating: Two-Stage

Upon a call for heating, the HEAT module closes the first stage heating contacts beginning the firing sequence. First, the heat exchanger combustion blower begins operation. Upon positive proving of combustion airflow, a 60 second pre-purge cycle is executed. Then the ignition sequence takes place.

If ignition is not proven, the safety control locks out and must be manually reset. As long as there is a call for heat, the safety control can be reset, which starts another purge cycle and try for ignition. As additional heat is required, the HEAT module will close the second stage heating contacts and depending on heat module size, will open either the second stage of the gas valve, or a second stage gas valve.

During heating operation, an electronic flame safety control provides continuous flame supervision. If combustion should become unstable for any reason, heating will automatically shut down. On the low heat for all unit sizes and the medium heat for the 90 and 105 ton, after a one minute delay, plus another 60 second pre-purge cycle the ignition cycle begins. On all other heat sizes the heating section will be shutdown and locked out after the first shutdown due to flame instability, until manually reset at the ignition module and at the unit-mounted Human Interface Panel .

As the heating requirement is satisfied, the HEAT module will open the second stage heating relay, de-energizing the second stage of heat. When the requirement is fully satisfied, the first stage contacts are opened, de-energizing the first stage of heat.

Gas Heating: Modulating Gas

Upon a call for heating, the HEAT module closes the heating contacts, beginning the firing sequence. First, the heat exchanger combustion blower begins operation. Upon positive proving of combustion airflow, a pre-purge cycle is executed. Then the ignition sequence takes place.

If ignition is not proven, the safety control locks out and must be manually reset. As long as there is a call for heat, the safety control can be reset, which starts another purge cycle and try for ignition. Once ignited, as additional heat is required, the combustion air damper opens, increasing the firing rate. During heating operation, an electronic flame safety control provides continuous flame supervision. If combustion should become unstable for any reason, heating will automatically shut down and be blocked out until reset at the unit-mounted Human Interface panel.

As the heating requirement is satisfied, the HEAT module will modulate the combustion air damper closed, and the firing rate will lower to maintain the desired outlet temperature. When the requirement is fully satisfied, the heating contacts are opened, de-energizing the heat. The specific sequence of operation of the gas heat will depend on the size of the heat exchanger.

Electric Heating

The individual stages of electric heat will be sequenced on the zone demand signal from the zone sensor. The signal is sent to the UCM and the stages are sequenced based on load demand. The number of available stages will depend on the unit size and heat capacity selected.

Hot Water or Steam Heating

Upon a call for heat, the UCM will send a varying voltage signal to the valve actuator. The valve will modulate to meet building demand as indicated by the voltage signal. When heating is satisfied, the valve will modulate closed. A temperature sensor is located on the coldest section of the coil. When it senses an impending freeze condition, a signal is sent to the hydronic valve to drive it full open. If the supply fan is on, or if the outside air damper is open when this freezing condition is sensed, the supply fan is turned off and the outside air damper is closed.

Supply Air Tempering

For staged gas and electric heat units in the occupied Heating mode, but not actively heating, if the supply air temperature drops to 10°F below the Occupied zone heating temperature setpoint, one stage of heat will be brought on to maintain a minimum supply air temperature. The heat stage is turned off if the supply air temperature rises to 10°F above the Occupied zone heating temperature setpoint.

Auto Changeover

When the System Mode is "Auto," the mode will change to cooling or heating as necessary to satisfy the zone cooling and heating setpoints. The zone cooling and heating setpoints can be as close as 2°F apart.

Unoccupied Zone Temperature Control

Cooling and Heating

Cooling and/or heating modes can be selected to maintain Unoccupied zone temperature setpoints. For Unoccupied periods, heating, economizer operation or compressor operation can be selectively locked out at the Human Interface Panels.

CV, SZVAV, and VAV

Note: SZVAV exceptions are noted in parenthesis.

Space Pressure Control - Statitrac

A pressure transducer is used to measure and report direct space (building) static pressure. The user-defined control parameters used in this control scheme are space static pressure setpoint, space pressure deadband and exhaust enable point. As the economizer opens, the building pressure rises and once above the exhaust enable point, enables the exhaust fan and dampers or exhaust VFD. The exhaust dampers or VFD then modulate to maintain space pressure within the deadband.

Morning Warm-up Options (Not applicable to SZVAV)

This feature may be enabled on all types of factory installed heat units as well as cooling only units configured as "External Heat" (for example, VAV boxes with reheat). At the conclusion of Unoccupied mode, while the economizer (if supplied) is kept closed, the selected zone is heated to the user-defined Morning Warm-up setpoint (see descriptions below). The unit is then released to Occupied mode.

Full Capacity Morning Warm-up (MWU)

Full capacity Morning Warm-up uses full heating capacity, and heats the zone up as quickly as possible. Full heating capacity is provided until the Morning Warm-up setpoint is met. At this point, the unit is released to occupied mode.

Cycling Capacity Morning Warm-up (MWU)

Cycling capacity Morning Warm-up provides a more gradual heating of the zone. Normal zone temperature control with varying capacity is used to raise the zone temperature to the MWU zone temperature setpoint. This method of warm-up is used to overcome the "building sink" effect. Cycling capacity MWU will operate until the MWU setpoint is reached or for 60 minutes, then the unit switches to Occupied mode. A control algorithm is used to increase or decrease the amount of heat in order to achieve the MWU zone temperature setpoint.

Note: When using the Morning Warm-up option in a VAV heating/cooling rooftop, airflow must be maintained through the rooftop unit. This can be accomplished by electrically tying the VAV boxes to the VAV box output relay contacts on the Rooftop Module (RTM) or by using changeover thermostats. Either of these methods will assure adequate airflow through the unit and satisfactory heating of the building.

Emergency Override

When a LonTalk® communication protocol or BACnet® control network is installed, the user can initiate from the Tracer® Ensemble™ building automation system (BAS) (in the case of LCI), Tracer® SC+ or third party BAS (with either BCI or LCI) one of five predefined, not available to configure, Emergency Override sequences. All compressors, condenser fans and the Humidification output are de-energized for any Emergency Override sequence. Each Emergency Override sequence commands the unit operation as follows:

PRESSURIZE_EMERG:

- Supply Fan - On

- Supply Fan VFD - Max(if so equipped)
- Exhaust Fan - Off; Exhaust Dampers - Closed (if so equipped)
- OA Dampers - Open; Return Damper - Closed
- Heat - All heat stages off; Mod Heat output at 0 VDC
- Occupied/Unoccupied/VAV box output - Energized
- VOM Relay - Energized (if so equipped)
- Preheat Output - Off
- Return Fan - Off; Exhaust Dampers - Closed (if so equipped)
- Return VFD - Min (if so equipped)

EMERG_DEPRESSURIZE:

- Supply Fan - Off
- Supply Fan VFD - Min (if so equipped)
- Exhaust Fan - On; Exhaust Dampers - Open/Max (if so equipped)
- OA Dampers - Closed; Return Damper - Open
- Heat - All heat stages off; Mod Heat output at 0 VDC
- Occupied/Unoccupied/VAV box output - Energized
- VOM Relay - Energized (if so equipped)
- Preheat Output - Off
- Return Fan - On; Exhaust Dampers - Open (if so equipped)
- Return VFD - Max (if so equipped)

EMERG_PURGE:

- Supply Fan - On
- Supply Fan VFD - Max (if so equipped)
- Exhaust Fan - On; Exhaust Dampers Open (if so equipped)
- OA Dampers - Open; Return Damper - Closed
- Heat - All heat stages off; Mod Heat output at 0 VDC
- Occupied/Unoccupied/VAV box output - Energized
- VOM Relay - Energized (if so equipped)
- Preheat Output - Off
- Return Fan - On; Exhaust Dampers - Open (if so equipped)
- Return VFD - Max (if so equipped)

EMERG_SHUTDOWN:

- Supply Fan - Off
- Supply Fan VFD - Min (if so equipped)
- Exhaust Fan - Off; Exhaust Dampers Closed (if so equipped)
- OA Dampers - Closed; Return Damper - Open
- Heat - All heat stages off; Mod Heat output at 0 VDC
- Occupied/Unoccupied/VAV box output - Energized
- VOM Relay - Energized (if so equipped)
- Preheat Output - Off
- Return Fan - Off; Exhaust Dampers - Closed (if so equipped)
- Return VFD - Min (if so equipped)

EMERG_FIRE - Input from fire pull box/system:

- Supply Fan - Off
- Supply Fan VFD - Min (if so equipped)
- Exhaust Fan - Off; Exhaust Dampers Closed (if so equipped)
- OA Dampers - Closed; Return Damper - Open
- Heat - All heat stages off; Mod Heat output at 0 VDC
- Occupied/Unoccupied/VAV box output - Energized
- VOM Relay - Energized (if so equipped)
- Preheat Output - Off
- Return Fan - Off; Exhaust Dampers - Closed (if so equipped)
- Return VFD - Min (if so equipped)

Ventilation Override Module (VOM)

The user can customize up to five different override sequences for purposes of ventilation override control. If more than one VOM sequence is being requested, the sequence with the highest priority is initiated first. Sequence hierarchy is the sequence "A" (UNIT OFF) is first, with sequence "E" (PURGE with Duct Pressure Control) last. A ventilation override mode can be initiated by closing any of the five corresponding binary inputs on the VOM module. A binary output is provided on the VOM module to provide remote indication of an active VOM mode. All compressors, condenser fans and the Humidification output are de-energized for any VOM sequence. The factory default definitions for each mode are as follows:

UNIT OFF sequence "A"

When complete system shutdown is required the following sequence can be used.

- Supply Fan - Off
- Supply Fan VFD - Min (if so equipped)
- Exhaust Fan - Off; Exhaust Dampers - Closed (if so equipped)
- OA Dampers - Closed; Return Damper - Open
- Heat - All heat stages off; Mod Heat output at 0 VDC
- Occupied/Unoccupied/VAV box output - Deenergized
- VOM Relay - Energized
- Preheat Output - Off
- Return Fan - Off; Exhaust Dampers - Closed (if so equipped)
- Return VFD - Min (if so equipped)
- OA Bypass Dampers - Open (if so equipped)
- Exhaust Bypass Dampers - Open (if so equipped)

PRESSURIZE sequence "B"

Perhaps a positively pressurized space is desired instead of a negatively pressurized space. In this case, the supply fan should be turned on with VFD at 100% speed and exhaust fan should be turned off.

- Supply Fan - On
- Supply Fan VFD - Max (if so equipped)
- Exhaust Fan - Off; Exhaust Dampers - Closed (if so equipped)
- OA Dampers - Open; Return Damper - Closed
- Heat - All heat stages off; Mod Heat output at 0 VDC
- Occupied/Unoccupied/VAV box output - Energized
- VOM Relay - Energized
- Preheat Output - Off
- Return Fan - Off; Exhaust Dampers - Closed (if so equipped)
- Return VFD - Min (if so equipped)
- OA Bypass Dampers - Open (if so equipped)
- Exhaust Bypass Dampers - Open (if so equipped)

EXHAUST sequence "C"

With only the exhaust fans running (supply fan off), the space that is conditioned by the rooftop would become negatively pressurized. This is desirable for clearing the area of smoke from the now-extinguished fire, possibly keeping smoke out of areas that were not damaged.

- Supply Fan - Off
- Supply Fan VFD - Min (if so equipped)
- Exhaust Fan - On; Exhaust Dampers Open (if so equipped)
- OA Dampers - Closed; Return Damper - Open
- Heat - All heat stages off; Mod Heat output at 0 VDC
- Occupied/Unoccupied/VAV box output - Deenergized
- VOM Relay - Energized
- Preheat Output - Off
- Return Fan - On; Exhaust Dampers - Open (if so equipped)
- Return VFD - Max (if so equipped)

- OA Bypass Dampers - Open (if so equipped)
- Exhaust Bypass Dampers - Open (if so equipped)

PURGE sequence "D"

Possibly this sequence could be used for purging the air out of a building before coming out of Unoccupied mode of operation on VAV units or for the purging of smoke or stale air if required after a fire.

- Supply Fan - On
- Supply Fan VFD - Max (if so equipped)
- Exhaust Fan - On; Exhaust Dampers Open (if so equipped)
- OA Dampers - Open; Return Damper - Closed
- Heat - All heat stages off; Mod Heat output at 0 VDC
- Occupied/Unoccupied/VAV box output - Energized
- VOM Relay - Energized
- Preheat Output - Off
- Return Fan - On; Exhaust Dampers - Open (if so equipped)
- Return VFD - Max (if so equipped)
- OA Bypass Dampers - Open (if so equipped)
- Exhaust Bypass Dampers - Open (if so equipped)

PURGE with duct pressure control sequence "E"

This sequence can be used when supply air control is required for smoke control.

- Supply Fan - On
- Supply Fan VFD - (If so equipped) Controlled by Supply Air Pressure Control function; Supply Air Pressure High Limit disabled
- Exhaust Fan - On; Exhaust Dampers Open (if so equipped)
- OA Dampers - Open; Return Damper - Closed
- Heat - All heat stages off; Mod Heat output at 0 VDC
- Occupied/Unoccupied/VAV box output - Energized
- VOM Relay - Energized
- Preheat Output - Off
- Return Fan - On; Exhaust Dampers - Open (if so equipped)
- Return VFD - Max (if so equipped)
- OA Bypass Dampers - Open (if so equipped)
- Exhaust Bypass Dampers - Open (if so equipped)

To use a RHI the unit must be equipped with an optional Inter-Processor Communications Bridge (IPCB) module. The RHI can be located up to 1,000 feet from the unit. A single RHI can be used to monitor and control up to four (4) rooftops, each containing an IPCB.

Human Interface Panel (HI)

The Human Interface (HI) Panel provides a 2 line X 40 character clear English liquid crystal display and a 16 button keypad for monitoring, setting, editing and controlling. The Human Interface Panel is mounted in the unit's main control panel and is accessible through an independent door.

The optional remote mount version of the Human Interface (RHI) Panel has all the functions of the unit mount version except Service Mode.

Human Interface Panel Main Menu

- **STATUS** — used to monitor all temperatures, pressures, humidities, setpoints, input and output status.
- **CUSTOM** — allows the user to create a custom status menu consisting of up to four (4) screens of the data available in the Status menu.
- **SETPOINTS** — used to review and/or modify all the factory preset Default setpoints and setpoint source selections.

- **DIAGNOSTICS** — used to review active and historical lists of diagnostic conditions. More than 100 different diagnostics can be read at the Human Interface Panel. The last 20 unique diagnostics can be held in an active history buffer log.
- **SETUP** — Control parameters, sensor source selections, function enable/disable, output definitions, and numerous other points can be edited in this menu. All points have factory preset values so unnecessary editing is kept to a minimum.
- **CONFIGURATION** — Preset with the proper configuration for the unit as it ships from the factory, this information would be edited only if certain features were physically added or deleted from the unit. For example, if a field supplied Ventilation Override Module was added to the unit in the field, the unit configuration would need to be edited to reflect that feature.
- **SERVICE** — used to selectively control outputs (for compressors, fans, damper position, etc.) for servicing or troubleshooting the unit. This menu is accessible only at the unit mounted Human Interface Panel.

Demand Limit (Not applicable to SZVAV)

This mode is used to reduce electrical consumption at peak load times. When demand limiting is needed, mechanical cooling and/or heating operation are either partially or completely disabled in order to save energy.

The definition of Demand Limit is user-definable at the Human Interface Panel. Demand Limit mode is initiated via a field supplied switch or contact closure (GBAS 0-5 VDC module or GBAS 0-10 VDC module) or via a communicated request (LCI or BCI). When the request for demand limit has been cancelled, the unit cooling and/or heating functions will become fully enabled.

Generic Building Automation System Module (GBAS 0-5 / 0-10 VDC)

The Generic Building Automation System Module (GBAS) is used to provide broad control capabilities for building automation systems other than the Trane Tracer Summit™ building automation system. The modules differ on the input signal and the number of binary I/O.

The following inputs and outputs are provided:

Analog Inputs — Four analog inputs, controlled via a field provided potentiometer or a VDC signal.

Table 1. Analog inputs (0-5 VDC, 0-10 VDC)

Set Point	System Control
Occupied Zone Cooling Setpoint	CV & SZVAV
Unoccupied Zone Cooling Setpoint	ALL
Occupied Zone Heating Setpoint	CV & SZVAV
Unoccupied Zone Heating Setpoint	ALL
Supply Air Cooling Setpoint	CV, SZVAV, VAV ^(a)
Supply Air Heating Setpoint	CV, SZVAV, VAV ^(a)
Space Static Pressure Setpoint	ALL
Supply Air Static Pressure Setpoint	VAV
Minimum Outside Air Flow Setpoint	ALL
Morning Warm Up Setpoint	CV & VAV
Economizer Dry Bulb Enable Setpoint	ALL
Minimum Outside Air Position Setpoint	ALL
Occupied Humidification Setpoint	ALL
Unoccupied Humidification Setpoint	ALL

Table 1. Analog inputs (0-5 VDC, 0-10 VDC) (continued)

Set Point	System Control
Occupied Dehumidification Setpoint	ALL
Unoccupied Dehumidification Setpoint	ALL

^(a) With discharge temperature control only

Analog Outputs — Four analog outputs that can be configured to be any of the following:

Table 2. Analog outputs (0-10 VDC only)

Output	System Control
Outdoor Air Temperature	ALL
Zone Temperature	ALL
Supply Air Temperature	CV, SZVAV, VAV ^(a)
Supply Air Pressure	SZVAV & VAV
Space Pressure	ALL
Space Relative Humidity	ALL
Outdoor Air Relative Humidity	ALL
Space CO2 Level	ALL
Compressor Staging (%)	ALL
Heat Staging (%)	ALL
Outdoor Air Damper Position	ALL
Outdoor Airflow	ALL
Occupied Humidification Setpoint	ALL
Unoccupied Humidification Setpoint	ALL

^(a) With discharge temperature control only

Binary Outputs — each of the five relay outputs can be mapped to any/all of the available diagnostics.

Binary Input — the single binary input can initiate or terminate the Demand Limit mode of operation via a field supplied switch or contact closure.

Frost Avoidance

Evaporator Coil Frost Protection - Frostat™

A temperature sensor on each evaporator circuit is used to determine if the coil is getting close to a freezing condition. Mechanical cooling capacity is shed as necessary to prevent icing. The Frostat™ system eliminates the need for hot gas bypass and utilizes the suction line surface temperature sensor near the TXV bulb location to shed cooling when coil frosting conditions occur. The supply fans are not shut off and will de-ice the coil. Timers prevent the compressors from rapid cycling.

Steam and Hot Water Coil - Freeze Avoidance

Freeze Avoidance is a feature which helps prevent freezing of steam or hot water heat coils during periods of unit inactivity and low ambient temperatures. Whenever the unit supply fan is off, the outdoor air temperature is monitored. If the temperature falls below a predetermined value, the heating valve is opened to a position selected at the unit mounted Human Interface to allow a minimum amount of steam or hot water to flow through the coil and avoid freezing conditions.

Occupied/Unoccupied Switching

There are three ways to switch Occupied/Unoccupied:

- Night Setback (NSB) Panel
- Field-supplied contact closure (hard wired binary input to RTM) (CV, SZVAV and VAV)
- Tracer (or third party BAS with LCI or BCI module)

Night Setback Sensors

The Trane night setback sensors are programmable with a time clock function that provides communication to the rooftop unit through a two-wire communications link. The desired transition times are programmed at the night setback sensor and communicated to the rooftop.

Night setback (unoccupied mode) is operated through the time clock provided in the sensors with night setback. When the time clock switches to night setback operation, the outdoor air dampers close and heating/cooling can be enabled or disabled depending on setup parameters. As the building load changes, the night setback sensor energizes the rooftop heating/cooling (if enabled) function and the evaporator fan. The rooftop unit will cycle through the evening as heating/cooling (if enabled) is required in the space. When the time clock switches from night setback to occupied mode, all heating/cooling functions begin normal operation.

When using the night setback options with a VAV heating/cooling rooftop, airflow must be maintained through the rooftop unit. This can be accomplished by electrically tying the VAV boxes to the VAV Box output relay contacts on the Rooftop Module (RTM) or by using changeover thermostats. Either of these methods will assure adequate airflow through the unit and satisfactory temperature control of the building.

Occupied/Unoccupied Input on the RTM

This input accepts a field supplied switch or contacts closure such as a time clock.

Trane Tracer® Ensemble™ or BAS System

The Tracer® Ensemble™ building management system or a third party BAS (with LCI or BCI module) can control the Occupied/Unoccupied status of the rooftop.

Timed Override Activation - ICS

This function is operational when the RTM is selected as the Zone Temperature Sensor source at the Human Interface Panel. When this function is initiated by the push of an override button on the ICS sensor, the Tracer Ensemble will switch the unit to the Occupied mode. Unit operation (Occupied mode) during timed override is terminated by a signal from Tracer.

Timed Override Activation - Non-ICS

This function is active whenever the RTM is selected as the Zone Temperature Sensorsource at the Human Interface Panel. When this function is initiated by the push of an override button on the zone sensor, the unit will switch to the Occupied mode. Automatic Cancellation of the Timed Override Mode occurs after three hours of operation.

Economizer Controls

Comparative Enthalpy Control of Economizer

An optional comparative enthalpy system is used to control the operation of the economizer, and measures the temperature and humidity of both return air and outside air to determine which source has lower enthalpy. This system allows true comparison of outdoor air and return air enthalpy by measurement of outdoor air and return air temperatures and humidities.

Reference Enthalpy Control of Economizer

The optional reference enthalpy compares outdoor air temperature and humidity to the economizer enthalpy control setpoint. If outdoor air temperature and humidity are below the economizer enthalpy control setpoint, the economizer will operate freely. This system provides more sophisticated control where outdoor air humidity levels may not be acceptable for building comfort and indoor air quality.

Dry Bulb Temperature Control of Economizer

The optional dry bulb system measures outdoor temperature comparing it to the economizer control temperature setpoint. If the outdoor temperature is below the economizer dry bulb temperature control setpoint, the economizer will operate freely. This system is best suited for arid regions where the humidity levels of outside air would not be detrimental to building comfort and indoor air quality.

Refrigeration Circuit Lead/Lag

Refrigeration Circuit lead/Lag is a user-selectable feature through the Human Interface Panel available on all units without the eFlex™ variable speed option. After each request for compressor operation, the lead refrigeration circuit switches, thereby causing a more equitable or balanced run time among compressors.

Emergency Stop Input

A binary input is provided on the Rooftop Module (RTM) for installation of field provided switch or contacts for immediate shutdown of all unit functions.

Anti-Short Cycle Protection

A standard feature provided to prevent excessive cycling and premature wear of the compressors, contactors and related components.

High Duct Temperature Sensor

Two manual reset, high temperature limit thermostats are provided. One is located in the discharge section of the unit set at 240°F and the other in the return air section of the unit set at 135°F. If either setpoint is reached, the rooftop unit is shut down.

CO₂ Control - Demand Control Ventilation (DCV)

A ventilation reset function that provides the necessary ventilation for occupants and reduces energy consumption by minimizing the outdoor air damper position (or the OA flow setpoint with Traq) below the Building Design Minimum, while still meeting the ASHRAE Std 62.1-2004 ventilation requirements.

- If the space CO₂ level is greater than or equal to the CO₂ Design Setpoint, the outdoor air damper will open to the Design Min Outdoor Air Damper (or OA Flow) Setpoint. If there is a call for economizer cooling, the outdoor air damper may be opened further to satisfy the cooling request.
- If the space CO₂ level is less than or equal to the CO₂ Minimum Setpoint, the outdoor air damper will close to the DCV Minimum Outdoor Air Damper (or OA Flow) Setpoint. If there is a call for economizer cooling, the outdoor air damper may be opened further to satisfy the cooling request.
- If the space CO₂ level is greater than the CO₂ Minimum Setpoint and less than the CO₂ Design Setpoint, the outdoor air damper position is (or OA flow) modulated proportionally to the Space CO₂ level relative to a point between the CO₂ Min Setpoint and the CO₂ Design Setpoint. If there is a call for economizer cooling, the outdoor air damper may be opened further to satisfy the cooling request.

Note: CO₂ sensor used with Demand Control Ventilation must be powered from an external power source or separate 24 VAC transformer.

Figure 17. CO₂ control

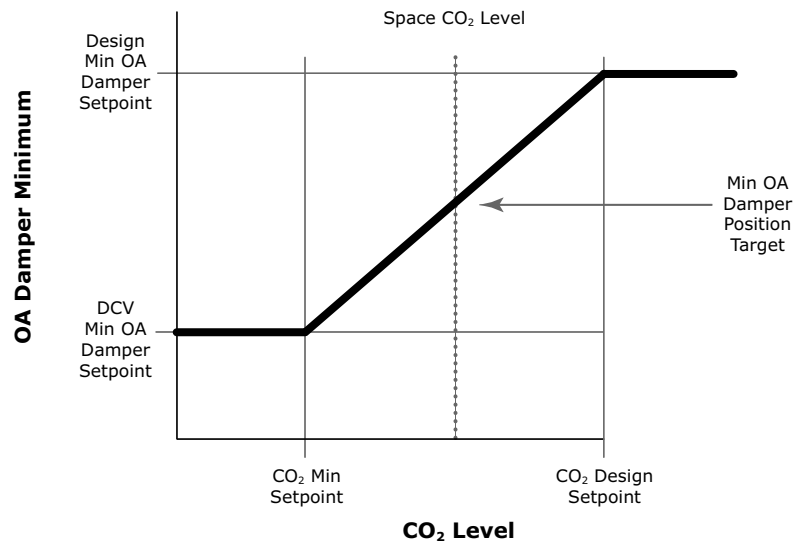

Humidification Control

A relay output is provided to control an externally connected, field supplied humidifier. Logic is provided for Occupied and Unoccupied humidification control with safeguards to prevent cycling between humidification and dehumidification

Return Fan Control

A return fan reduces the load on the supply fan motor or can allow a unit to operate at a higher static pressure. The return fan VFD is modulated independently to maintain desired return air plenum pressure. In all other cases the return fan is turned on or off with the supply fan.

Low Charge Protection

The low charge feature measures the entering and leaving evaporator temperatures on each circuit to calculate a superheat value for each circuit. The superheat value is used for multiple purposes:

- Displayed at the Human Interface panel to assist the service technician with unit charging and diagnostics
- A diagnostic message displayed at the Human Interface panel, warning of a low charge situation when the unit is just slightly undercharged. The unit will be allowed to run.
- A diagnostic message displayed at the Human Interface panel, warning of a low charge situation when the unit is undercharged. The undercharged circuit will be locked out to protect the compressors.

Condenser Fan Cycling

The IntelliPak™ 2 controller cycles condenser fans based on ambient temperature and saturated condensing temperature to ensure the optimum operating conditions for the unit.

LonTalk® Building Automation System

The LonTalk® communication protocol for the IntelliPak (LCI-I) controller expands communications from the unit UCM network to a Tracer® Ensemble™ building automation system or third party building automation system. Utilizing LonTalk®, the BAS allows external setpoint and configuration adjustment and monitoring of status and diagnostics. The LCI-I utilizes an FTT-10A free topology transceiver, which supports non-polarity sensitive, free topology wiring—which in turn allows the system installer to utilize star, bus, and loop architectures. This controller works in standalone mode, peer-to-peer with one or more other



units, or when connected to a Tracer® Ensemble™ or a third party building automation system that supports LonTalk®. The LCI-I controller is available as a factory or field-installed kit.

BACnet® Building Automation Control Network

The BACnet® control network for IntelliPak (BCI-I) expands communications from the unit UCM network to the Tracer® Ensemble™ building automation system or third party building automation system. Utilizing BACnet, the BAS allows external setpoint and configuration adjustment and monitoring of status and diagnostics. The BCI-I utilizes the BACnet defined MS/TP protocol as defined in ASHRAE standard 135-2004. This controller works in standalone mode, with Tracer® Ensemble™ or when connected to a third party building automation system that supports BACnet. The BCI-I controller is available as a factory or field-installed kit.

AirFi™ Wireless Communication Interface

Trane AirFi™ Wireless Comm replaces the BACnet communication link and sensor wire on Tracer® building automation systems for faster, easier, lower-risk installation and life-cycle savings.

Twinning

Twinning is a master unit and one or more similarly configured slave unit(s) operating cooperatively, to provide higher capacity and/or redundancy at partial capacity.

Twinning requires an LCI module be installed in each unit and is accomplished by binding variables between unit communication modules, communicating common setpoints and conditions (temperatures, pressures, fan speeds, damper positions, occupancy, states, etc.), and allowing each unit to run independent algorithms.

Note: BCI-I does not have twinning capabilities.

Twinned units must share a common supply and return duct network. Twinned units operate:

- as part of a Trane Integrated Comfort System installation, with Tracer Summit.
- on an inter-operable project with a third party LonTalk.
- as an independent group (bound via Rover or third party tool).

Energy Recovery Wheel

Variable effectiveness is a means to control the capacity of an energy wheel. Normal wheel sizing is for worst case winter/summer load; therefore, at part load the wheel may be oversized and variable effectiveness is justifiable. Variable effectiveness control can be used in any application where the outdoor air temperature may fall between the discharge air setpoint and the temperature at which heating is required.

For example, a job may have a required supply air set point of 55°F. A typical return air temperature may be 70°F and the outside air temperature 40°F. The energy wheel could heat the supply air to over 60°F, but by employing variable effectiveness, the energy wheel capacity can be modulated to exactly match the required supply air temperature without using additional heating or cooling. Therefore, variable effectiveness control can significantly add to the amount of energy saved in a year.

Variable effectiveness can be accomplished by varying the wheel rotational speed or by bypassing a portion of the exhaust air around the wheel matrix. IntelliPak 2 utilizes an exhaust air bypass damper for capacity control.

When unit mode and psychrometric conditions allow, the energy recovery wheel will turn "ON". The wheel uses energy from the return air stream to temper the outside air stream, thereby reducing the load of the space without utilizing mechanical cooling and heating.

Figure 18. Variable sensible effectiveness control

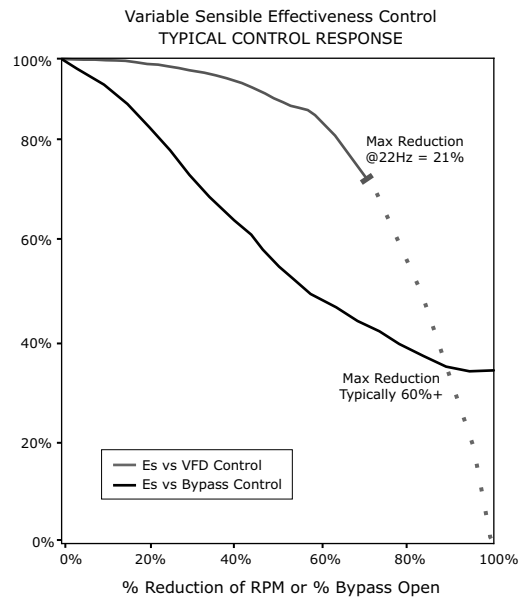

Modulating Hot Gas Reheat

When space conditions allow, the modulating hot gas reheat function activates the reheat mode. The reheat valve and cooling valve are modulated to control the discharge air temperature to the discharge air temperature reheat setpoint (default 70 °F).

In reheat mode, the reheat valve is commanded (15 to 85%) to control to the discharge air reheat setpoint and the cooling valve mirrors the reheat valve position (85 to 15%).

Low Ambient Function

The low ambient function is a head pressure control scheme that allows compressor operation at a lower ambient temperature, without tripping the low pressure cutout switch (LPC). For this function, normal condenser fan staging applies. The first condenser fan on each circuit is modulated by a variable frequency drive (VFD). The fan speed is modulated to control to the saturated condenser temperature control Setpoint.

Low Ambient Compressor Lockout

This function will lock out the compressor if the outdoor air temperature is below the low ambient compressor lock out temperature setpoint. The factory setpoint is 50°F on standard units and 0°F on low ambient units. This setpoint is adjustable at the Human Interface Panel. Compressors will be locked out when outdoor air temperatures fall below the selected temperature and will be allowed to start again when temperatures rise 5°F above the setpoint.

Evaporative Condenser

The evaporative condenser function is a method of head pressure control that utilizes water as the condensing medium rather than air. This method of head pressure control provides increased unit efficiency.

The function activates whenever a compressor is active on a circuit and modulates the condenser fan speed to control the Saturated Condenser Temperature (SCT) Control Setpoint. If the saturated condenser temperature continues to rise above the SCT upper limit, the sump pump will be energized.

Once the temperature falls below the SCT lower limit, the sump pump will be de-energized.

The function has a sump water freeze protection, a periodic partial water flush to reduce contaminant build up, an external drain request, and a water treatment option.

Figure 19. Evaporative condenser flow schematic

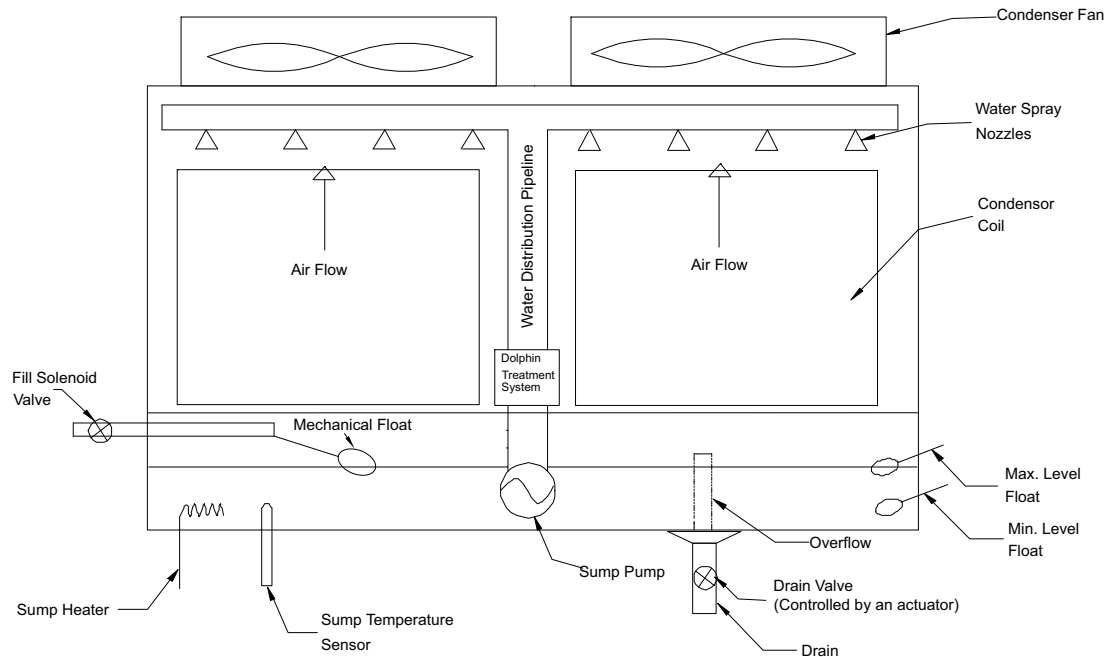

Rapid Restart (RR) Only

The IntelliPak™ controls platform will support rapid restart unit startup after every power cycle occurs. There will be no assumptions about how long the unit has been OFF, so the unit will perform the same startup sequence with each occurrence.

The following is a list of the control operations:

- This is a cooling only function and will not function with heating.
- RR will target a four-minute maximum time from start signal to 100% cooling with an upper limit of five minutes.
- Outside air temperatures relative to the Low Ambient Lockout Setpoint will determine whether economizer cooling or DX staging will be the primary source for cooling.
- The use of economizing below low ambient lockout (typically 50°F) during the RR function will be a selectable option on the HI.
- Until the RR termination conditions are met, the unit will ramp the outside air damper open, if under economizer operation. Until the RR termination conditions are met, the unit will stage DX mechanical cooling, if available, at six second intervals.
- Supply fan capacity will increase accordingly: CV & SZVAV: Supply fan operation at full airflow will be utilized.
- VAV: Once the supply fan proving switch is closed, the supply fan speed will ramp to 50% command, then control to normal discharge static pressure control limited by the high duct static limit.
- Building pressure will always be in control.
- The unit will indicate via local HI and remote BAS that the RR event is active.
- Valid RR temperature sensor or return air temperature sensor is required to determine initialization and deactivation of RR relative to RR critical temperature setpoint. If this sensor fails, the unit will terminate RR when the discharge temperature sensor indicates a value below the active SA cooling setpoint – 1/2 deadband.
- Limit OA humidity infiltration to humidity greater than 20% RH.



Application Considerations

High Capacity Evaporator

Rooftops are popular because of their “packaged” nature. Everything needed is contained in one box; mix-matching is neither necessary nor available. With this convenience comes some disadvantages, among them correctly matching cooling capacity to building load. For example, a 105 ton rooftop would need to be used on an application that is 91 tons, simply because the ton rooftop does not meet capacity. Matching the rooftop’s capacity to the building load is critical, which is why the IntelliPak line offers a high capacity coil option on its rooftops.

Capacity tables for both standard and high capacity units are available in the cooling data section of this catalog. Use the pressure drops associated with the high capacity coil option by adding them to the total static pressure used to size the supply fan motor. eFlex™, variable speed compressors also help units match the load needed by varying the compressor down to 15% of full load.

eFlex™ Variable Speed

A state of the art Trane eFlex™ variable speed compressor is combined with fixed capacity compressors to provide a superior part load efficiency (IEER) option. Compressor designs are optimized and selected to maximize part load performance. Continuous capacity from 15-100% means that discharge air temperature is controlled within +/-1°F. This eliminates discharge air temperature swings caused by cycling fixed capacity compressors, improves humidity control, and leads to increased comfort in the space.

Exhaust/Return Fan Options

When is it necessary to provide building exhaust? Whenever an outdoor air economizer is used, a building generally requires an exhaust system. The purpose of the exhaust system is to exhaust the proper amount of air to prevent over or under-pressurization of the building. The goal is to exhaust approximately 10% less air than the amount of outside air going into the building. This maintains a slightly positive building pressure.

The reason for applying either a return, or exhaust fan is to control building pressure. The Trane 100% modulating exhaust system with Statitrac is an excellent choice for controlling building pressure in the majority of applications. For more demanding applications, Trane's 100% modulating return fan system with Statitrac is an excellent choice for systems with high return static pressure losses, or duct returns. Both systems employ direct digital control technology to maintain building pressure. Either return or exhaust fan systems with Statitrac may be used on any rooftop application that has an outdoor air economizer.

A building may have all or part of its exhaust system in the rooftop unit. Often, a building provides exhaust external to the air conditioning equipment. This external exhaust must be considered when selecting the rooftop exhaust system.

With an exhaust fan system, the supply fan motor and drives must be sized to overcome the total system static pressure, including return losses, and pull return air back to the unit during non-economizer operation. However, a supply fan can typically overcome return duct losses more efficiently than a return air fan system. Essentially, one large fan by itself is normally more efficient than two fans in series because of only one drive loss, not two as with return fan systems.

In a return fan system, the return fan is in series with the supply fan, and operates continuously whenever the supply fan is operating to maintain return air volume. The supply fan motor and drives are sized to deliver the design CFM based on internal and discharge static pressure losses only. The return fan motor and drives are sized to pull the return CFM back to the unit based on return duct static. Therefore, with a return fan system, the supply fan ordinarily requires less horsepower than a system with an exhaust fan.

Exhaust/Return Fan Systems

- 100% modulating exhaust with Statitrac direct space sensing building pressurization control (with or without exhaust variable frequency drives)
- 100% modulating exhaust without Statitrac
- 100% modulating plenum return airfoil fan with Statitrac direct space sensing building pressurization control with variable frequency drive
- 100% modulating plenum return airfoil fan without Statitrac
- Drivers for applying either return or exhaust fan systems include economy, building pressure control, code requirements, and generally accepted engineering practices

100% Modulating Exhaust with Statitrac™ Control, Constant Volume (CV) and Variable Air Volume (VAV) Units

For both CV and VAV rooftops, the 100% modulating exhaust discharge dampers (or VFD) are modulated in response to building pressure. A differential pressure control system, Statitrac, uses a differential pressure transducer to compare indoor building pressure to atmospheric pressure. The FC exhaust fan is turned on when required to lower building static pressure to setpoint. The Statitrac control system then modulates the discharge dampers (or VFD) to control the building pressure to within the adjustable, specified deadband that is set at the Human Interface Panel. Economizer and return air dampers are modulated independent of the exhaust dampers (or VFD) based on ventilation control and economizer cooling requests.

Advantages:

- The exhaust fan runs only when needed to lower building static pressure.
- Statitrac compensates for pressure variations within the building from remote exhaust fans and makeup air units.
- The exhaust fan discharges in a single direction resulting in more efficient fan operation compared to return fan systems.
- When discharge dampers are utilized to modulate the exhaust airflow, the exhaust fan may be running unloaded whenever the economizer dampers are less than 100% open.

The Trane 100% modulating exhaust system with Statitrac provides efficient control of building pressure in most applications simply because 100 percent modulating exhaust discharge dampers (or VFD) are controlled directly from building pressure, rather than from an indirect indicator of building pressure, such as outdoor air damper position.

100% Modulating Exhaust System without Statitrac, Constant Volume (CV) Units Only

This fan system has performance capabilities equal to the supply fan. The FC exhaust fans are started by the economizer's outdoor air damper position and the exhaust dampers track the economizer outdoor air damper position. The amount of air exhausted by this fan is controlled by modulating discharge dampers at the fan outlet. The discharge damper position is controlled by a signal that varies with the position of the economizer dampers. When the exhaust fans start, the modulating discharge dampers are fully closed, and exhaust airflow is 15 to 20% of total exhaust capabilities. The Trane 100 percent modulating exhaust system provides excellent linear control of building exhaust in most applications where maintaining building pressure is not important.

Advantages:

- The exhaust fan runs only when the economizer reaches the desired exhaust enable point.
- Exhaust dampers are modulated based on the economizer position.
- When discharge dampers are utilized to modulate the exhaust airflow, the exhaust fan may be running unloaded whenever the economizer dampers are less than 100 percent open.

100% Modulating Exhaust with or without Statitrac Control, SZVAV Units

The overall scheme will remain very similar to non-Single Zone VAV units with Space Pressure Control with the exception of the dynamic Exhaust Enable Setpoint.

For SZVAV the user will select an Exhaust Enable Setpoint during the 100% Fan Speed Command. Once selected, the difference between the Exhaust Enable Setpoint and Design OA Damper Minimum Position at 100% Fan Speed Command will be calculated. The difference calculated will be used as an offset to be added to the Active Building Design OA Minimum Position Target to calculate the dynamic Exhaust Enable Target to be used throughout the Supply Fan Speed/OA Damper Position range.

Advantages:

- The exhaust fan runs only when the economizer reaches the desired exhaust enable point.
- Exhaust dampers are modulated based on the economizer position.
- The exhaust fan discharges in a single direction resulting in more efficient fan operation compared to return fan systems.
- When discharge dampers are utilized to modulate the exhaust airflow, the exhaust fan may be running unloaded whenever the economizer dampers are less than 100% open.

The Trane 100% modulating exhaust system provides excellent linear control of building exhaust in most applications where maintaining building pressure is not important.

100% Modulating Return Fan Systems with Statitrac Control, Constant Volume (CV) and Variable Air Volume (VAV) Units

For both CV and VAV applications, the IntelliPak 2 rooftop unit offers 100% modulating return fan systems. A differential pressure control system, Statitrac, uses a differential pressure transducer to compare indoor building pressure to atmospheric pressure.

The return fan exhaust dampers are modulated, based on space pressure, to control the building pressure to within the adjustable, specified deadband that is set at the Human Interface Panel. A VFD modulates the return fan speed based on return duct static pressure.

Economizer and return air dampers are modulated independent of the exhaust dampers based on ventilation control and economizer cooling requests.

Advantages:

- The return fan operates independently of the supply fan to provide proper balance throughout the airflow envelope.
- Statitrac compensates for pressure variations within the building from remote exhaust fans and makeup air units.
- The return fan acts as both exhaust and return fan based on operation requirements.

The Trane 100% modulating return system with Statitrac provides efficient control of building pressure in applications with higher return duct static pressure and applications requiring duct returns. Exhaust discharge dampers are controlled directly from building pressure, return fan VFD is controlled from return static pressure, and return/economizer dampers are controlled based on ventilation control and economizer cooling requests.

100% Modulating Return Fan without Statitrac Control, Constant Volume (CV) Units Only

The return fan runs continuously while the supply fan is energized. The exhaust discharge dampers are modulated in response to building pressure. Economizer and return air dampers are modulated independent of the exhaust dampers based on ventilation control, and economizer cooling requests.

Advantages:

- The return fan enhances total system static capability.
- The return fan discharges in two directions, thereby balancing exhaust and unit return air volumes.

Other Cooling Options

Cooling, Rapid Restart Units Only

This is for applications where the space has a high heat load with critical temperature control requirements. A typical application is a computer room that has a large number of routers and servers. If the cooling capacity is lost due to a power interruption, the temperature in the room can rise as much as 3-4°F per minute. Once power is restored (e.g., backup generator has started), the cooling capacity needs to be maximized as soon as possible to help get the space under control. Once cooling capacity has been maximized, the unit can then manage the load using its normal capacity control algorithms.

Supply and Return Airflow Configurations

The typical rooftop installation has both the supply and return air paths routed through the roof curb and building roof. However, many rooftop installations require horizontal supply and/or return from the rooftop because of a building's unique design or for acoustic considerations.

There are several ways to accomplish horizontal supply, see [Table 3, p. 42](#) and/or [Table 4, p. 43](#).

Figure 20. Left/right unit orientation and horizontal airflow

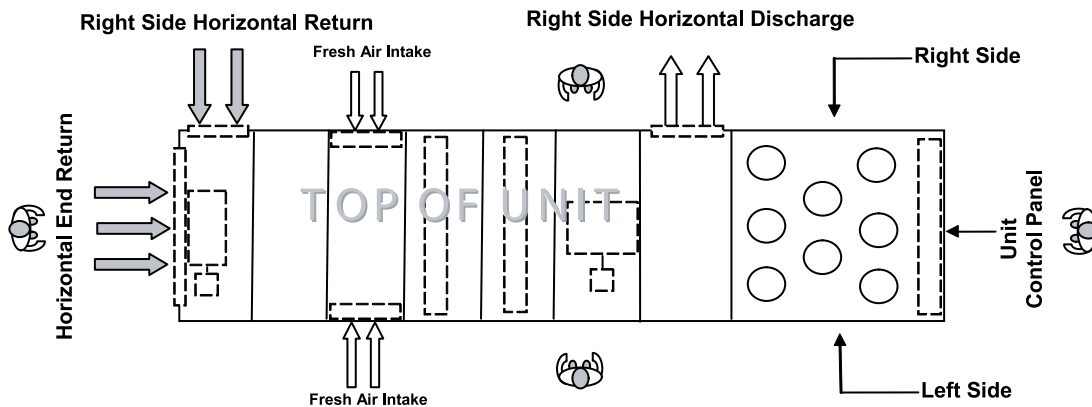

Table 3. Supply airflow configuration

Cabinet Configuration	Supply Airflow Discharge Direction	Type	Acceptable Application	With Bag Final Filters	With Cartridge Final Filters	With HEPA Final Filters
Standard Length	Downflow - Standard Option	Cooling Only	Yes	No	No	No
Standard Length	Horizontal - Right Side - Standard Option	Cooling Only	Yes	No	No	No
Standard Length	Horizontal - Left Side - Field Convertible	Cooling Only	Field Convert	No	No	No
Standard Length	Downflow - Standard Option	Gas, Electric, Steam, Hot Water Heat	Yes	No	No	No
Standard Length	Horizontal - Right Side - Standard Option	Gas, Electric, Steam, Hot Water Heat	Yes	No	No	No
Standard Length	Horizontal - Left Side - Field Convertible	Gas, Electric, Steam, Hot Water Heat	No	No	No	No

Table 3. Supply airflow configuration (continued)

Cabinet Configuration	Supply Airflow Discharge Direction	Type	Acceptable Application	With Bag Final Filters	With Cartridge Final Filters	With HEPA Final Filters
4 ft Blank Section	Downflow - Standard Option	Cooling Only	Yes	Yes	Yes	Yes
4 ft Blank Section	Horizontal - Right Side - Standard Option	Cooling Only	Yes	Yes	Yes	Yes
4 ft Blank Section	Horizontal - Left Side - Field Convertible	Cooling Only	Field Convert	Yes	Yes	Yes
4 ft Blank Section	Downflow - Standard Option	Gas, Electric, Steam, Hot Water Heat	No	No	No	No
4 ft Blank Section	Horizontal - Right Side - Standard Option	Gas, Electric, Steam, Hot Water Heat	No	No	No	No
4 ft Blank Section	Horizontal - Left Side - Field Convertible	Gas, Electric, Steam, Hot Water Heat	No	No	No	No
8 ft Blank Section	Downflow - Standard Option	Cooling Only, Steam Heat, Hot Water Heat	Yes	Yes	Yes	Yes
8 ft Blank Section	Horizontal - Right Side - Standard Option	Cooling Only, Steam Heat, Hot Water Heat	Yes	Yes	Yes	Yes
8 ft Blank Section	Horizontal - Left Side - Field Convertible	Cooling Only, Steam Heat, Hot Water Heat	Field Convert	Yes	Yes	Yes
8 ft Blank Section	Downflow - Standard Option	Gas ^(a) or Electric ^(b)	Yes	No	High Temp	High Temp
8 ft Blank Section	Horizontal - Right Side - Standard Option	Gas ^(a) or Electric ^(b)	Yes	No	High Temp	High Temp
8 ft Blank Section	Horizontal - Left Side - Field Convertible	Gas ^(a) or Electric ^(b)	Field Convert	No	High Temp	High Temp

^(a) Not available with 2.5M MBh heater

^(b) Multi-piece units with electric heat and eight foot blank section are not field convertible from right side horizontal to left side horizontal configuration.

Note: For left/right unit orientation, see [Figure 20, p. 42](#).

Table 4. Return airflow configuration

Airflow Config	Exhaust Fan VFD	Exhaust Fan No VFD	Return Fan VFD	Return Fan No VFD
Vertical	Yes	Yes	Yes	Yes
Horizontal - Right	Yes	Yes	Yes	Yes
Horizontal - Left	No	Field Convert	No	No
Horizontal - End	Yes	Yes	No	No

Note: For left/right unit orientation, see [Figure 20, p. 42](#).

When using an IntelliPak 2 Rooftop for horizontal supply and/or return, an additional pressure drop must be added to the supply external static to account for the 90 degree turn the air is making. This additional pressure drop depends on airflow and rooftop size, but a range of 0.10 inches to 0.30 inches can be expected. The openings on the rooftop all have a one inch lip around the perimeter to facilitate ductwork attachment.

Corrosive Atmospheres

Trane's IntelliPak® Rooftops are designed and built to industrial standards and will perform to those standards for an extended period depending on the hours of use, the quality of maintenance performed, and the regularity of that maintenance.

One factor that can have an adverse effect on unit life is operation in a corrosive environment. Since the Microchannel condenser coil is an all-aluminum design, it provides a high level of corrosion protection on its own. Uncoated, it withstands a salt spray test in accordance with ASTM B117 for 1,000 hours. When rooftops are operated in highly corrosive environments, Trane recommends the corrosion protected condenser coil option.

This corrosion protection option meets the most stringent testing in the industry, including ASTM B117 Salt Spray test for 6,000 hours and ASTM G85 A2 Cyclic Acidified Salt Fog test for 2,400 hours. The acid fog test is the most stringent available today. This coating is added after coil construction covering all tubes, headers, fins and edges. The design provides superior protection from any corrosive agent. For evaporator coils, epoxy coating can be utilized as a design special.



Application Considerations

IntelliPak paint innately handles harsh weather, including most coastal and salt environments and direct sun. The unit paint was salt spray tested in accordance with ASTM B117 and UV weathering resistance tested in accordance with ASTM G155 Test cycle 1 for 2000 hours. For further detail on the paint testing, refer to PROD-SLB034*-EN

Note: *Field coating is not allowed on Microchannel coils.*

Ventilation Override Sequences

One of the benefits of using an exhaust fan rather than a return fan, in addition to the benefits of lower energy usage and improved building pressurization control, is that the rooftop can be used as part of a ventilation override system. Several types of sequences can be easily done when exhaust fans are a part of the rooftop system.

What would initiate the ventilation override control sequence? Typically, a manual switch is used and located near the fire protection control panel. This enables the fire department access to the control for use during or after a fire. It is also possible to initiate the sequence from a field-installed automatic smoke detector. In either case, a contact closure begins the ventilation override control sequence.

Trane can provide five (5) different ventilation override sequences on both CV and VAV IntelliPak® rooftops. For convenience, the sequences are factory preset but are fully field edited from the Human Interface Panel or Tracer. Any or all five sequences may be “locked” in by the user at the Human Interface Panel.

The user can customize up to five (5) different override sequences for purposes such as smoke control. The following parameters within the unit can be defined for each of the five sequences:

- Supply Fan - on/off
- Variable Frequency Drives - on (60 Hz)/off (0 Hz)/controlling
- Exhaust/Return Fan - on/off
- Exhaust Dampers - open/closed
- Economizer Dampers - open/closed
- Heat - off/controlling (output for) VAV Boxes - open/controlling

Compressors and condenser fans are shut down for any Ventilation Override sequence. Factory preset sequences include unit Off, Exhaust, Purge, Purge with duct pressure control, and Pressurization. Any of the user-defined Ventilation Override sequences can be initiated by closing a field supplied switch or contacts connected to an input on the Ventilation Override Module. If more than one ventilation override sequence is being requested, the sequence with the highest priority is initiated. Refer to the Ventilation Override Mode (VOM) information in the Control section of this catalog for more details on each override sequence.

Natural Gas Heating Considerations

Trane uses heavy gauge stainless steel throughout the construction of its natural gas tubular exchangers. These heat exchangers can be applied with confidence, particularly with full modulation control, when mixed air temperatures are below 50°F, and low ambient temperatures can cause condensation to form on the heat exchanger. The IntelliPak® natural gas heat exchangers are not recommended for applications with mixed air conditions entering the heat exchanger below 30°F to ensure adequate leaving air heating temperature. For airflow limitations and temperature rise across the heat exchanger information, see , p. 116.

Acoustic Considerations

The best time to make provisions to reduce sound transmission to the occupied space is during the project design phase. Proper placement of rooftop equipment is critical to reducing sound transmitted into the building. The most economical means of avoiding an acoustical problem is to locate rooftop equipment away from acoustically-sensitive areas. If possible, locate rooftop equipment above corridors, utility rooms, restrooms, or other areas where higher sound levels are acceptable.

It is not possible to totally quantify the effect of the building structure on sound transmission, since this depends on the response of the roof and building members to the sound and vibration of the unit components. However, the following guidelines have been proven through experience to help reduce sound transmission through the building structure:

- Never cantilever the condensing section of the rooftop unit; a structural cross member must support this end of the unit.
- Locate the unit's center of gravity close to (or over) a column or main support beam to minimize roof deflection and vibration-related noise.
- If the roof structure is very light, roof joists should be replaced by a structural shape in the critical areas described above.
- If several units are to be placed on one span, they should be staggered to reduce deflection over that span.

For more information:

- ASHRAE. 2015. *ASHRAE Handbook – HVAC Applications* (Chapter 48: Noise and Vibration Control). Atlanta, GA: ASHRAE.
- ASHRAE. 2011. *Practical Guide to Noise and Vibration Control for HVAC Systems*. Atlanta, GA: ASHRAE.
- Guckelberger, D. 2000. "Controlling Noise From Large Rooftop Units," *ASHRAE Journal* (May): pp. 55-62.
- Trane. Guckelberger, D. and Bradley, B. 2006. *Acoustics in Air Conditioning*, ISS-APM001-EN. La Crosse, WI: Inland Printing Company.
- Trane. Murphy, J. and Harshaw, J. 2012. *Rooftop VAV Systems*, SYS-APM007-EN. La Crosse, WI: Inland Printing Company.

In addition, the Trane TAP™ Acoustics Program allows for modeling of various sound paths to predict sound levels in the occupied space. The software models airborne sound from supply- and return-air paths, as well as duct breakout and roof transmission sound, so that the designer can identify potential sound problems and make design alterations before equipment installation. TAP is also capable of modeling the effect of outdoor sound on adjacent properties. This program is available from Trane's Customer Direct Service Network (C.D.S.), ask your local Trane representative for additional information.

High Entering Return Temperature Applications

Some applications may have high entering return temperatures. It is recommended that the dry bulb temperatures in any application not exceed 95°F for extended periods of time. If this is a requirement, please work with the Applications or Product Support group in developing a specific assessment. Other factors, such as wet bulb and ambient temperatures, will also affect the system's reaction.

Clearance Requirements

The recommended clearances identified in unit dimensions should be maintained to assure adequate service capability, maximum capacity and peak operating efficiency. A reduction in unit clearance could result in condenser coil starvation or warm condenser air recirculation. If the clearances shown are not possible on a particular job, consider the following:

- Do the clearances available allow for major service work such as changing compressors or coils?
- Do the clearances available allow for proper outside air intake, exhaust air removal and condenser airflow?
- If screening around the unit is being used, is there a possibility of air recirculation from the exhaust to the outside air intake or from condenser exhaust to condenser intake?
- Do clearances meet all applicable codes?

Actual clearances which appear inadequate should be reviewed with a local Trane sales engineer.

When two or more units are to be placed side by side, the distance between the units should be increased to 150 percent of the recommended single unit clearance. The units should also be staggered, see [Figure 21, p. 46](#) and , for the following reasons:

- To reduce span deflection if more than one unit is placed on a single span. Reducing deflection discourages sound transmission.

- To assure proper diffusion of exhaust air before contact with the outside air intake of adjacent unit.

Figure 21. Unit placement

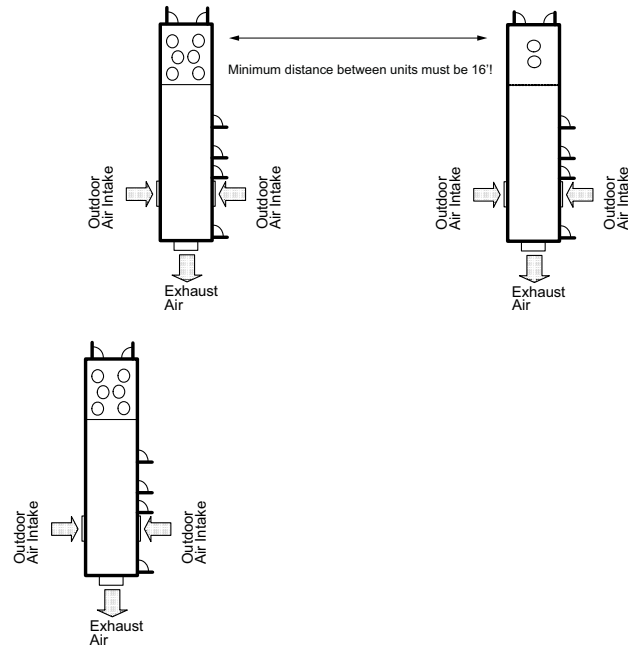

Duct Design

It is important to note that the rated capacities of the rooftop can be met only if the rooftop is properly installed in the field. A well-designed duct system is essential in meeting these capacities.

The satisfactory distribution of air throughout the system requires that there be an unrestricted and uniform airflow from the rooftop discharge duct. This discharge section should be straight for at least several duct diameters to allow the conversion of fan energy from velocity pressure to static pressure.

However, when job conditions dictate elbows be installed near the rooftop outlet, the loss of capacity and static pressure may be reduced through the use of guide vanes and proper direction of the bend in the elbow. The high velocity side of the rooftop outlet should be directed at the outside radius of the elbow rather than the inside as illustrated in .

Figure 22. Duct design

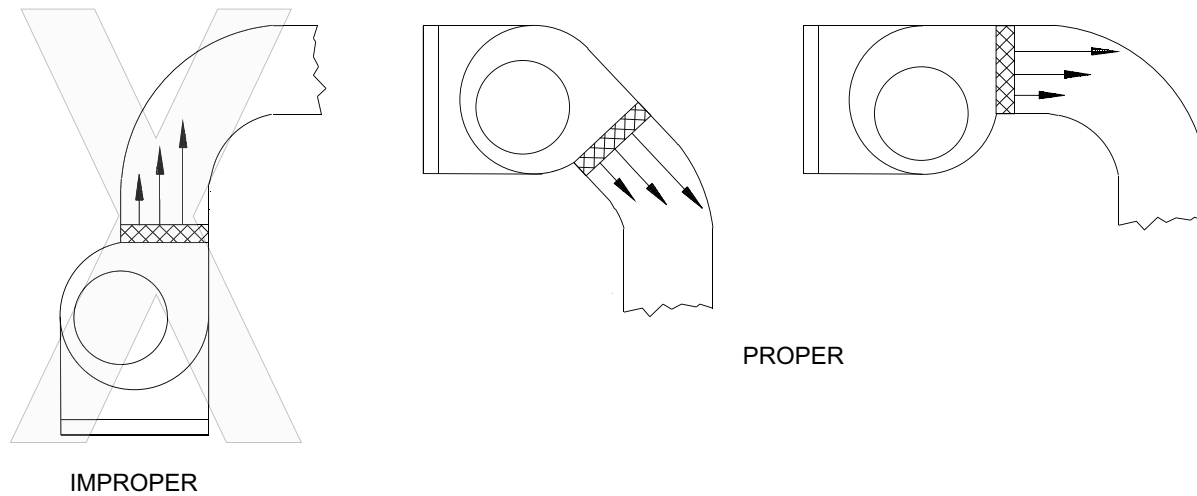

Energy Recovery Wheel

For applications where the air streams within the rooftop must be isolated, consider using alternative technologies that guarantee separation of the air streams.

Important: Do not use energy wheels in applications where the exhaust air is contaminated with harmful toxins or biohazards or where even a minor mixing of the air streams presents a health risk. See *Installation Operation Maintenance (RT-SVX24*-EN)* for more information.

The energy recovery option was designed as a partial flow outside air system, where the required outside air is less than 100 percent. IntelliPak 2 monitors outside air, return air, and zone conditions. It compares them with setpoints (set in the rooftop human interface) and checks for suitable energy recovery system operation. Energy recovery can be activated when both supply and exhaust fans are in operation. Heat can be recovered when the return air dry bulb temperature is greater than the outside air dry bulb temperature.

Energy recovery is disabled when economizer cooling operation is requested. Economizer cooling in energy recovery wheel equipped units requires the exhaust air and outside air bypass dampers to be open and the recovery wheel motor to be off. The energy recovery wheel can provide free cooling when outside air enthalpy is greater than return air enthalpy. In general, energy recovery works well in applications where a high outside airflow minimum is required, often because of high occupancy.

Modulating Hot Gas Reheat

Often supply fan VAV modulation, staged compressor control, or the addition of an eFlex™ variable speed compressor are sufficient in handling building humidity in a wide range of indoor load conditions. Applications where non-peak load conditions can be dominated by latent loads are candidates for the Hot Gas Reheat option. This includes many applications subject to ASHRAE Standard 62 requirements.

When a Hot Gas Reheat coil is energized, it increases the air temperature after exiting the evaporator coil. While this provides dehumidification, this is not a dehumidifier. The main function of the Packaged RTU is to provide zone temperature control. For times when dehumidification is needed, the hot gas reheat will be energized.

Applications which should be investigated before using the standard modulating hot gas reheat option, and will require additional investigation include the following:

- Process applications
- Units utilized as a make-up air or 100% outside air units
- Zones with dramatically varying load conditions (sanctuaries, locker rooms, gymnasiums, etc.



Application Considerations

Generally, the standard Modulating Hot Gas Reheat option requires a call for cooling to initiate. If there is no call for cooling, and there is a desire for dehumidification, another solution will need to be investigated. The IntelliPak™ packaged rooftop systems include non-standard solutions which can be considered for these types of applications.

Evaporative Condenser

Water Supply—Suspended particulate matter, mineral concentrations, trash and debris can adversely affect performance of any water-cooled device. If not managed, mineral concentrations can result in clogged water system hardware, heat exchanger restriction and heat transfer loss. Trane's evaporative condenser is designed to greatly minimize performance problems that may occur from the by-products of water evaporation.

Incoming Water Supply Line—A float valve is provided to maintain sump water level during condenser operation. A field installed gate valve may be installed on the condenser water supply line. An 80 to 100 mesh field supplied strainer may be installed in the condenser water supply line to help prevent the introduction of debris. The condenser water supply line should be flushed thoroughly prior to connection to the unit. Local codes may require back-flow prevention on the condenser water supply line.

Water Discharge and Drain Line—Care and judgment should be exercised in selecting a water discharge site.

Local Site Discharge—Rooftop or simple storm sewer discharge is generally acceptable. Do not routinely direct sump discharge onto areas where the byproducts of water evaporation or water treatment products are undesirable.

Sewer Discharge—The quantities of mineral and debris in the discharge water are actually very small, and do not cause problems when diluted in normal sewer flow. Check local codes to identify any special requirements for sewer discharge. Regardless of the disposal method used, local codes, state or federal standards for water disposal must be followed.

Freeze Protection—For operation in ambient temperatures below 32°F, optional sump heater and controls are available to provide operation down to 10°F. In colder climates water supply line and drain piping will require field installed freeze protection. Generally low wattage heat tape on the water lines is sufficient protection.

Make-up Water Considerations:

Water Saving Methods—A programmable flush cycle is initiated to remove mineral deposits and particulates from the sump. Fresh water can be cycled into the sump as a portion of the existing water is drained. The intervals between drains are adjustable from 0 - 12 hours. When set to 0, the periodic blowdown is disabled.

A more efficient approach is utilizing the Conductivity Controller option, which performs blowdowns based on water quality readings from the conductivity sensor in the sampling tube. Users can set a limit based on water quality testing they have performed in their area, when this adjustable setpoint is exceeded the unit will conduct a blowdown for a period of time set by the user. This allows the user to save water by only performing blowdowns when they are required. Water level is maintained by the internal float valve.

Water Treatment—Water treatment is required on all evaporative condensing units. Even when an optional Dolphin WaterCare System is utilized, water must still be maintained and monitored throughout the unit life cycle.

Note: *Local codes may require the use of chemicals for water treatment. Different chemical feeder systems are available to fit a wide variety of requirements and budgets. Check with local code officials to determine installation requirements.*

Low Ambient Operation — Remote Human Interface Recommendation

Who wants to be on a roof at subzero temperatures? We can understand a service technician's reluctance to do this; that's why we offer a remote mounted human interface panel. The service technician can troubleshoot and diagnose in the comfort of a mechanical room.



Selection Procedure

This section outlines a step-by-step procedure that may be used to select a Trane air-cooled single-zone air conditioner. Air-cooled models should be selected based on dry bulb (DB) conditions. For specific model selection, utilize TOPSS or contact the local Trane Sales Office. This sample selection is based on the following conditions:

Note: When calculating capacities for evaporative condensers, use ambient wet bulb (WB).

Summer Design	
Summer outdoor design conditions	95 DB/76 WB ambient temperature
Summer room design conditions	78 DB/65 WB
Total cooling load	980 MBh (81.6 tons)
Sensible cooling load	735 MBh (61.25 tons)
Outdoor air ventilation load	154.0 MBh (12.8 tons)
Return air temperature	78 DB/65 WB
Winter design:	
Winter outdoor design conditions	0°F
Return air temperature	70°F
Total heating load	720 MBh
Winter outdoor air ventilation load	288.6 MBh
Total winter heating load	1008.6 MBh
Air delivery data:	
Supply fan CFM	36,000 CFM
External duct static pressure	1.86 in wg
Minimum outdoor air ventilation	3,600 CFM
fan CFM	36,000 CFM
Return air duct negative static pressure	0.3 in wg
Electrical characteristics:	
Voltage/cycle/phase	460/60/3
Unit Accessories	<ul style="list-style-type: none"> • Gas fired heat exchanger - high heat • Downflow supply and upflow return • High efficiency throwaway filters • Economizer • Modulating 100% exhaust

Cooling Capacity Selection

1. Nominal Unit Size Selection

A summation of the peak cooling load and the outside air ventilation load shows: 980 MBh + 154.0 MBh = 1134.0 MBh required unit capacity. From , p. 65, a 105 ton unit with standard capacity evaporator coil at 80 DB / 65 WB, 95°F outdoor air temperature and 36,000 total supply CFM is 1,237 MBh total and 1,037 MBh sensible. Thus, a nominal 105 ton unit with standard capacity evaporator coil is selected.

2. Evaporator Coil Entering Conditions

Mixed air dry bulb temperature determination:

Selection Procedure

Using the minimum percent of OA (3,600 CFM ÷ 36,000 CFM = 10%), determine the mixture dry bulb to the evaporator.

$$RADB + \% \text{ OA (OADB - RADB)} = 78 + (0.10) (95 - 78) = 78 + 1.5 = 79.5^\circ\text{F}$$

Approximate wet bulb mixture temperature:

$$RAWB + \% \text{ OA (OAWB - RAWB)} = 65 + (0.10) (76 - 65) = 65 + 1.1 = 66.1^\circ\text{F}$$

3. Determine Supply Fan Motor Heat Gain

Having selected a nominal 105 ton unit, the supply fan bhp can be calculated. The supply fan motor heat gain must be considered in final determination of unit capacity.

Table 5. Determine unit total static pressure at design supply CFM:

Supply Duct Static Pressure	2.2 inches
Evaporator Coil (, p. 120)	0.64 inches
Return Duct Negative Static Pressure	0.30
Heat Exchanger (, p. 120)	0.03
Throwaway Filter (, p. 120)	0.26
Economizer Damper ^(a) (, p. 120)	0.57
Unit Total Static Pressure	4.0

^(a) Add either the economizer damper value or return damper value, depending on which static pressure is greater. (Do not use both.)

Using total of 36,000 CFM and total static pressure of 4.0 inches, enter 40.4 bhp with 1,097 rpm required for the 36" supply fan. Supply fan motor heat gain = 109.0 MBh, or 109.0 MBh ÷ 36000 CFM x 1.085 = 2.8°F supply fan motor heat. See supply fan graph in , p. 111.

4. Determine Total Required Cooling Capacity

Required capacity = Total peak load + OA load + supply air fan motor heat

$$\text{Required capacity} = 980.0 + 154.0 + 109.0 = 1243.0 \text{ MBh (103.6 tons)}$$

5. Determine Unit Capacity

From , p. 65, unit total capacity at 79.5 DB/66.1 WB entering the evaporator, 36,000 supply air CFM, 95°F outdoor ambient is 1,251 MBh (104.2 tons) with 996 MBh (83 tons) sensible capacity.

6. Determine Leaving Air Temperature

Unit sensible heat capacity corrected for supply air fan motor heat = 996 MBh sensible - 109.0 MBh motor heat = 887 MBh.

Supply air dry bulb temperature difference =

$$\frac{\text{Sensible Btu}}{1.085 \times \text{Supply CFM}} =$$

$$\text{Sensible Btu} = 887 \text{ MBh} / (1.085 \times 36,000 \text{ CFM}) = 23.0$$

$$\text{Supply air dry bulb} = 79.5 \text{ DB} - 23.0 = 56.5 \text{ leaving evaporator coil}$$

$$\frac{\text{Total Btu}}{4.5 \times \text{Supply CFM}} =$$

$$\text{Unit enthalpy difference} = 1,251 \text{ MBh} \div (4.5 \times 36,000 \text{ CFM}) = 7.72 \text{ Btu/lb.}$$

$$\text{Leaving enthalpy} = h (\text{ent WB}) - h (\text{diff}). \text{ From Table 9, p. 63, } h (\text{ent WB}) = 30.9 \text{ Btu/lb.}$$

$$\text{Leaving enthalpy} = 30.9 \text{ Btu/lb.} - 7.72 \text{ Btu/lb.} = 23.18 \text{ Btu/lb.}$$

$$\text{Supply air wet bulb} = 54.9 \text{ leaving evaporator coil.}$$

$$\text{Leaving air temperature} = 56.5 \text{ DB/54.9 WB}$$

Heating Capacity Selection

1. Determine air temperature entering heating module

Mixed air temperature = RADB + % OA (OADB - RADB) = 70 + (0.10) (0 - 70) = 63°F

Supply air fan motor heat temperature rise = 109000 Btu ÷ (1.085 × 36000 CFM) = 2.8°F

Air temperature entering heating module = 63.0 + 2.8 = 65.8°F

2. Determine total winter heating load

Total winter heating load = peak heating load + ventilation load - supply fan motor heat = 720 + 288.6 - 109.0 = 899.6 MBh

a. Electric heating system

Unit operating on 460/60/3 power supply.

From [Table 54, p. 116](#), kW may be selected for a nominal 105 ton unit operating 460-volt power. The 265 kW heat module (904.4 MBh) will satisfy the winter heating load of 899.6 MBh.

[Table 54, p. 116](#) shows an air temperature rise of 23.2°F for 36,000 CFM through the 265 kW heat module.

Unit supply temperature at design heating conditions = mixed air temperature + air temperature rise = 65.8°F + 23.2°F = 89.0°F.

b. Gas heating system (natural gas)

From [p. 116](#) select the high heat module (1,440 MBh output) to satisfy winter heating load of 899.6 MBh at unit CFM.

[Table , p. 116](#) also shows an air temperature rise of 37.0°F for **36,000 CFM** through the heating module.

Unit supply temperature at design heating conditions = mixed air temperature + air temperature rise = 65.8°F + 37.0°F = 102.8°F.

c. Hot water heating system

Assume a hot water supply temperature of 190°F and an entering coil temperature of 65.8°F.

Subtract the mixed air temperature from the hot water temperature to determine the ITD (initial temperature difference).

ITD = 190°F - 65.0°F = 125°F. Divide the winter heating load by ITD = 1008.6 MBh ÷ 125°F = 8.0 Q/ITD.

From [Table 57, p. 117](#), select the low heat module. By interpolation, a Q/ITD of 8.0 can be obtained at a gpm of 40.0. Water pressure drop at 40.0 gpm is 0.33 ft. of water.

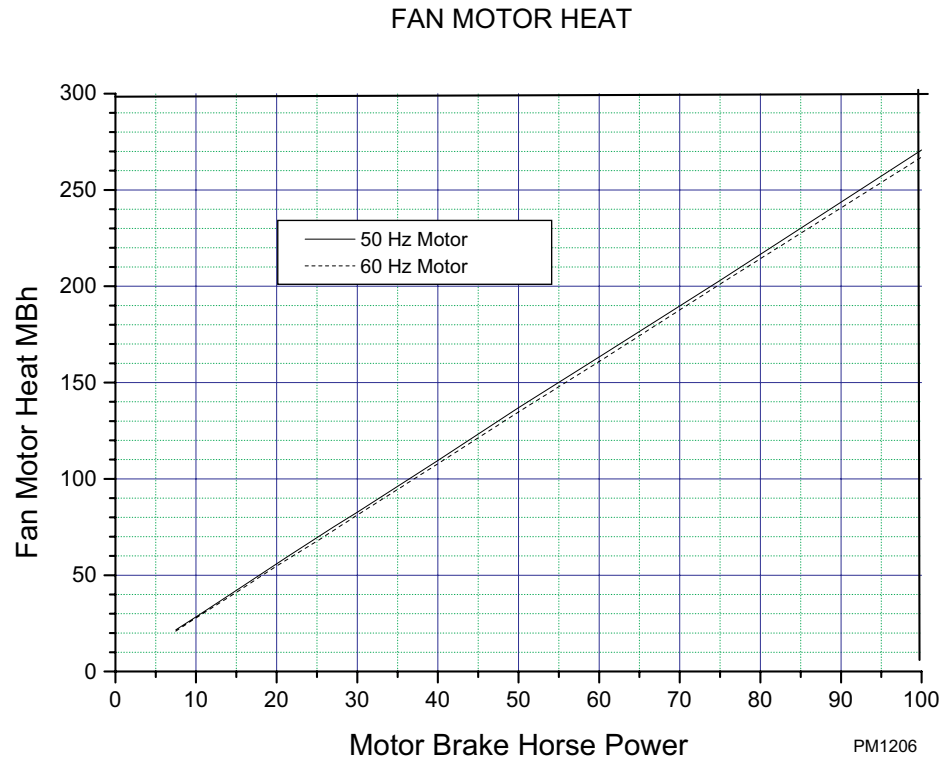
Figure 23. Fan motor heat

Heat module temperature rise is determined by:

$$\frac{\text{Total Btu}}{1.085 \times \text{Supply CFM}} = \Delta T$$

$$\frac{1008600}{1.085 \times 36000} = 25.8$$

Unit supply air temperature = mixed air temperature + air temperature rise = 65.4 + 25.8 = 91.2°F.

d. Steam heating system

Assume a 15 psig steam supply.

From [Table 59, p. 119](#), the saturated temperature steam is 250°F. Subtract mixed air temperature from the steam temperature to determine ITD.

$$\text{ITD} = 250^\circ\text{F} - 65.0^\circ\text{F} = 185^\circ\text{F}.$$

Divide winter heating load by ITD = 1008.6 MBh ÷ 185°F = 5.45 Q/ITD.

From [Table 58, p. 118](#), select the low heat module. The low heat module at 36,000 CFM has a Q/ITD = 7.45.

$$\text{Heat module capacity, Q} = \text{ITD} \times \text{Q/ITD} = 185^\circ\text{F} \times 7.45 \text{ Q/ITD} = 1378 \text{ MBh}$$

Heat module air temperature rise is determined by:

$$\frac{\text{Total Btu}}{1.085 \times \text{Supply CFM}} = \Delta T$$

$$\frac{1378000}{1.085 \times 36000} = 35.3$$

Unit supply temperature at design conditions = mixed air temperature + air temperature rise = 65.4°F + 35.3°F = 100.7°F.

e. Air delivery procedure

Supply fan performance tables include internal resistance of rooftop. For total static pressure determination, system external static must be added to appropriate component static pressure drop (evaporator coil, filters, optional economizer, optional exhaust fan, optional heating system, optional cooling only extended casing).

f. Supply fan motor sizing

The supply fan motor selected in the cooling capacity determination was 40.4 bhp and 1,097 rpm. Thus, a 40 hp supply fan motor is selected.

Enter , p. 127 to select the proper drive. For a 105 ton rooftop with 40 hp motor, a drive letter A - 1,100 rpm is selected.

g. Exhaust fan motor sizing

The exhaust/return fan is selected based on total return system negative static pressure and exhaust fan CFM. Return system negative static includes return duct static, and any other job site applicable static pressure drop.

Return duct static pressure = 0.30 inches.

Total return system negative static pressure = 0.30 inches.

Exhaust fan CFM = 36,000 CFM

From the exhaust fan curve (, p. 113), the required bhp is estimated at 21 bhp at 400 rpm. Thus, the exhaust fan motor selected is 25 hp.

To select a drive, enter Table 68, p. 127 for a 25 hp motor for a 105 ton unit. Drive selection number 4 - 400 rpm.

h. Return fan motor sizing

Return fan drive selection is shown on Table 69, p. 128. The same static pressure and CFM considerations must be taken for return fan size, horsepower, and drive selection as are required for exhaust fan sizing. However, since the return fan runs continuously the sensible heat generated by the return fan motor must be included in the entering evaporator coil mixed air temperature equation.

In this selection, if the return motor bhp is equal to the exhaust motor bhp, 21.44 bhp = 58.1 MBh ÷ (1.085 × 36,000 Return CFM) = 1.5°F added to the return air temperature.

Where altitudes are significantly above sea level, use Table 10, p. 64 and Figure 24, p. 63 for applicable correction factors.

i. Unit Electrical Requirements

Selection procedures for electrical requirements for wire sizing amps, maximum fuse sizing, and dual element fuses are given in the electrical service section of this catalog.

j. Altitude Corrections

The rooftop performance tables and curves of this catalog are based on standard air (.075 lbs/ft). If the rooftop airflow requirements are at other than standard conditions (sea level), an air density correction is needed to project accurate unit performance.

Figure 24, p. 63 shows the air density ratio at various temperatures and elevations. Trane rooftops are designed to operate between 40° and 90°F leaving air temperature. The procedure to use when selecting a supply or exhaust/return fan on a rooftop for elevations and temperatures other than standard is as follows:

- Determine the air density ratio using Figure 24, p. 63.
- Divide the static pressure at the nonstandard condition by the air density ratio to obtain the corrected static pressure.
- Use the actual CFM and the corrected static pressure to determine the fan rpm and

bhp from the rooftop performance tables or curves.

- The fan rpm is correct as selected.
- Bhp must be multiplied by the air density ratio to obtain the actual operating bhp.

In order to better illustrate this procedure, the following example is used: Consider a 90 ton rooftop unit that is to deliver 32,000 actual CFM at 3-inches total static pressure (tsp), 55°F leaving air temperature, at an elevation of 5,000 ft.

- From [Figure 24, p. 63](#), the air density ratio is 0.86.
- $Tsp = 3.0\text{-inches} / 0.86 = 3.49\text{ inches tsp}$.
- From the supply fan curve [Figure 26, p. 111](#) a 90 ton rooftop will deliver 32,000 CFM at 3.49 inches TSP at 997 rpm and an estimated 30 bhp.
- $Bhp = 30 \times 0.86 = 25.8\text{ bhp actual}$.
- The rpm is correct as selected - 997 rpm.

Compressor MBh, SHR, and kW should be calculated at standard and then converted to actual using the correction factors in [Table 10, p. 64](#). Apply these factors to the capacities selected at standard CFM so as to correct for the reduced mass flow rate across the condenser. Heat selections other than gas heat will not be affected by altitude. Nominal gas capacity (output) should be multiplied by the factors given in [Table 11, p. 64](#) before calculating the heating supply air temperature.

Evaporative Condensing Rooftop

For unit selection, air-cooled or evaporative condensers can be selected using the same calculations, however evaporative condenser capacities should be calculated based on Wet Bulb (WB) temperatures. For specific model selection, utilize TOPSS or contact the local Trane Sales Office.

Total Energy Recovery Wheel

Utilize TOPSS or contact the local Trane sales office to calculate required return air preheat temperature for the given minimum outdoor air temperature and return air relative humidity.

To calculate the supply and exhaust air conditions leaving the wheel, you must know the wheel effectiveness. Refer to [Table 66, p. 126](#) for total effectiveness measurements.

Note: *The effectiveness numbers shown assume equal supply and exhaust airflows. If the airflows are unbalanced, the effectiveness changes. Use TOPSS to determine effectiveness values for these conditions.*

Calculate Wheel Performance

Use the following equations to calculate supply air conditions. Use TOPSS to calculate exhaust air conditions and to obtain actual dry bulb temperature and enthalpy values for coil and equipment sizing.

1. Dry bulb temperature:

$$\text{Cooling: } T_{sa} = T_{oa} - (E \times (T_{oa} - T_{ra}))$$

$$\text{Heating: } T_{sa} = T_{oa} + (E \times (T_{ra} - T_{oa}))$$

where:

T_{sa} = Dry bulb temperature of supply air (°F)

T_{oa} = Dry bulb temperature of outside air (°F)

T_{ra} = Dry bulb temperature of return air (°F)

E = Sensible Effectiveness

2. Enthalpy:

$$\text{Cooling: } H_{sa} = H_{oa} - (E \times (H_{oa} - H_{ra}))$$

$$\text{Heating: } H_{sa} = H_{oa} + (E \times (H_{ra} - H_{oa}))$$

where:

H_{sa} = Enthalpy of supply air (Btu/ lb)

H_{oa} = Enthalpy of outside air (Btu/ lb)

H_{ra} = Enthalpy of return air (Btu/lb)

E = Total Effectiveness

After calculating these two points, use a psychrometric chart to obtain the supply air wet bulb temperature and/or grains moisture.

3. Energy wheel application example

In this example, a wheel sized for nominal 10,500 CFM will be used for the initial evaluation. The air pressure drop is 1.07 in. wg and the total effectiveness is 73% (see [Table 66, p. 126](#)). The total and latent effectiveness values are close to equal for Trane energy wheels. For this example, total effectiveness is assumed to be 73% in cooling mode and 75% in heating mode. TOPSS could be used to obtain the exact values.

a. Supply air conditions, cooling mode:

$$T_{sa} = T_{oa} - (E \times (T_{oa} - T_{ra})) = 95^{\circ}\text{F} - (.73 \times (95^{\circ}\text{F} - 75^{\circ}\text{F})) = 81^{\circ}\text{F}$$

$$H_{sa} = H_{oa} - (E \times (H_{oa} - H_{ra})) = 38.4 \text{ Btu/lb} - (.73 \times (38.4 \text{ Btu/lb} - 26.0 \text{ Btu/lb})) = 29.3 \text{ Btu/lb}$$

According to a psychrometric chart, the supply air wet bulb temperature is 64.4°F, 64 grains/lbm.

$$T_{sa} = T_{oa} + (E \times (T_{ra} - T_{oa})) = 10^{\circ}\text{F} + (.75 \times (70^{\circ}\text{F} - 10^{\circ}\text{F})) = 55^{\circ}\text{F}$$

$$H_{sa} = H_{oa} + (E \times (H_{ra} - H_{oa})) = 3.2 \text{ Btu/lb} + (.75 \times (22.7 \text{ Btu/lb} - 3.2 \text{ Btu/lb})) = 17.8 \text{ Btu/lb}$$

According to a psychrometric chart, the supply air wet bulb temperature is 45.5°F, 30 grains/lbm.

When designing the remainder of the air-handling system, remember to account for the air pressure drop imposed by the energy wheel.

Hot Gas Reheat Selection

The hot gas reheat coil is designed to deliver maximum reheat temperatures. Contact the local Trane Sales Office or refer to the IntelliPak™ TOPSS™ selection program to determine leaving air temperature, latent capacity, reheat sensible capacity, leaving unit dew point, and moisture removal when the unit is in reheat operation. If the reheat set point is not obtainable at the provided conditions the customer will be required to make adjustments to the conditions or change the reheat set point value. Please note that reheat operation will not be allowed when there is a call for heating or more than 50% call for cooling.



Model Number Description

DIGIT 1: Unit Type

S = Self-Contained (Packaged Rooftop)

Digit 2 — Unit Function

E = DX Cooling, Electric Heat
F = DX Cooling, Natural Gas Heat
L = DX Cooling, Hot Water Heat
S = DX Cooling, Steam Heat
X = DX Cooling, No Heat, Extended Casing

Digit 3 — System Type

H = Single Zone

Digit 4 — Development Sequence

J = Ninth

Digit 5, 6, 7 — Nominal Capacity

090 = 90 Ton Air-Cooled
105 = 105 Ton Air-Cooled
120 = 120 Ton Air-Cooled
130 = 130 Ton Air-Cooled
150 = 150 Ton Air-Cooled
100 = 100 Ton Evap Condenser
118 = 118 Ton Evap Condenser
128 = 128 Ton Evap Condenser
140 = 140 Ton Evap Condenser
162 = 162 Ton Evap Condenser

Digit 8 — Voltage Selection

4 = 460/60/3 XL
5 = 575/60/3 XL
C = 380/50/3 XL

Digit 9 — Heating Capacity Selection

0 = No Heat
1 = Electric heat 90/56 kW 60/50 Hz
2 = Electric heat 140/88 kW 60/50 Hz
3 = Electric heat 265/166 kW 60/50 Hz
4 = Electric Heat 300/188 kW 60/50 Hz
A = Low Gas Heat — 2-stage
B = Medium Gas Heat — 2-stage
C = High Gas Heat — 2-stage
D = Low Gas Heat — Modulating
E = Medium Gas Heat — Modulating
F = High Gas Heat — Modulating

Digit 10 — Heating (continued)

Steam or Hot Water Heat:

G = Low Heat - 1.0" (25mm) Valve
H = Low Heat - 1.25" (32mm) Valve
J = Low Heat - 1.5" (38mm) Valve
K = Low Heat - 2.0" (50mm) Valve
L = Low Heat - 2.50" (64mm) Valve
M = Low Heat - 3.0" (76mm) Valve
N = High Heat - 1.0" (25mm) Valve
P = High Heat - 1.25" (32mm) Valve
Q = High Heat - 1.5" (38mm) Valve
R = High Heat - 2.0" (50mm) Valve
T = High Heat - 2.50" (64mm) Valve
U = High Heat - 3.0" (76mm) Valve

DIGIT 10, 11 — Design Sequence

A-ZZ = (Factory Assigned) Sequence may be any letter A to Z, or any digit 1 to 9.

DIGIT 12 — Unit Configuration Selection

1 = One-Piece Unit w/o Blank Section
2 = One-Piece Unit w/4' Blank Section
3 = One-Piece Unit w/8' Blank Section
4 = Two-Piece Unit w/o Blank Section
5 = Two-Piece Unit w/4' Blank Section
6 = Two-Piece Unit w/8' Blank Section
7 = Three-Piece unit w/o Blank Section
8 = Three-Piece Unit w/4' Blank Section
9 = Three-Piece Unit w/8' Blank Section

DIGIT 13 — Airflow Direction

1 = Downflow Supply/Upflow Return
2 = Downflow Supply/Horiz End Return
3 = Downflow Supply/Horiz Right Return
4 = Right Side Horiz Supply/Upflow Return
5 = Right Side Horiz Supply/Horizontal End Return
6 = Right Side Horiz Supply/Horizontal Right Return

DIGIT 14 — Supply Fan Options

1 = Standard CFM
3 = Standard CFM - TEFC Motor(s)
4 = Low CFM
6 = Low CFM - TEFC Motor(s)
7 = Standard CFM - w/ Motor Shaft Grounding
9 = Standard CFM - TEFC Motor(s) w/ Shaft Grounding
A = Low CFM - w/ Motor Shaft Grounding
C = Low CFM - TEFC Motor(s) w/ Shaft Grounding

DIGIT 15 — Supply Fan Motor Selection

F = 15 hp
G = 20 Hp
H = 25 Hp
J = 30 Hp
K = 40 Hp
L = 50 Hp
M = 60 Hp
N = 75 Hp
P = 100 Hp

DIGIT 16 — Supply Fan RPM Selection

7 = 700
8 = 800
9 = 900
A = 1000
B = 1100
C = 1200
D = 1300
E = 1400
F = 1500
G = 1600
H = 1700
J = 1800
K = 1900
L = 2000

DIGIT 17 — Exhaust/Return Fan Options

0 = None
1 = Std CFM Exhaust Fan w/o Statitrac CV Only
2 = Low CFM Exhaust Fan w/o Statitrac CV Only
3 = Std CFM Exhaust w/o VFD w/ Statitrac
4 = Low CFM Exhaust w/o VFD w/ Statitrac
5 = Std CFM Exhaust w/ VFD w/ Bypass w/ Statitrac
6 = Low CFM Exhaust w/ VFD w/ Bypass w/ Statitrac
7 = Std CFM Exhaust w/ VFD w/o Bypass w/ Statitrac
8 = Low CFM Exhaust w/ VFD w/o Bypass w/ Statitrac
A = Std CFM Return w/o Statitrac CV Only
B = Low CFM Return w/o Statitrac CV Only
C = Std CFM Return w/ VFD w/ Bypass w/ Statitrac
D = Low CFM Return w/ VFD w/ Bypass w/ Statitrac
E = Std CFM Return w/ VFD w/o Bypass w/ Statitrac
F = Low CFM Return w/ VFD w/o Bypass w/ Statitrac

DIGIT 18 — Exhaust/Return Fan Motor Selection

0 = None
D = 7.5 Hp
E = 10 Hp
F = 15 Hp
G = 20 Hp
H = 25 Hp
J = 30 Hp
K = 40 Hp
L = 50 Hp
M = 60 Hp

DIGIT 19 — Exhaust/Return RPM Selection

0 = None
3 = 300
4 = 400
5 = 500
6 = 600
7 = 700
8 = 800
9 = 900
A = 1000
B = 1100
C = 1200
D = 1300
E = 1400

DIGIT 20 — System Control Selection

1 = Constant Volume (CV) (Zone Temperature Control)
2 = CV w/ Discharge Temp Control
4 = VAV w/ VFD Supply w/o Bypass (Discharge Temp Control)
5 = VAV w/ VFD Supply w/ Bypass (Discharge Temp Control)
6 = VAV – Single Zone VAV w/VFD w/o Bypass (Zone Temperature Control)
7 = VAV – Single Zone VAV w/VFD w/ Bypass (Zone Temperature Control)

DIGIT 21 — Outside Air and Economizer Option/Controls

A = 0-25% Motorized Damper
B = Economizer w/Dry Bulb
C = Economizer w/Reference Enthalpy
D = Economizer w/Comparative Enthalpy
E = Econ w/Outside Air Measure/Dry Bulb
F = Econ w/Outside Air Measure/Ref Enthalpy
G = Econ w/Outside Air Measure/Comp Enthalpy
H = Econ w/DCV/Dry Bulb^(a)
J = Econ w/DCV/Ref Enthalpy^(a)
K = Econ w/DCV/Comp Enthalpy^(a)

^(a) Requires CO₂ Zone Sensor(s)

DIGIT 22 — Damper Option

0 = Standard
1 = Low Leak
2 = Ultra Low Leak
U = Ultra Low Leak, AMCA 1A, w/ FDD (Design Special)

DIGIT 23 — Pre-Evaporator Coil Filter Selection

0 = Two Inch High Efficiency Throwaway
1 = Two Inch Throwaway Rack/Less Filters
2 = 90-95% Bag Filters w/ Prefilters
3 = Bag Filter Rack/Less Filters
4 = 90-95% Cartridge Filters w/ Prefilters
5 = Cartridge Rack/Less Filters
6 = 90-95% Low Pressure Drop Cartridge Filters w/ Prefilters
7 = Low Pressure Drop Cartridge Rack/Less Filters

DIGIT 24 — Blank Section Application Options

0 = None
A = 90-95% Bag w/ Prefilters
B = 90-95% Low Pressure Drop Cartridge w/ Prefilters
C = 90-95%, Cartridge Filters w/ Prefilters
D = 90-95% High Temp Cartridge w/ Prefilters
E = HEPA w/ Prefilters
F = High Temp HEPA w/ Prefilters

DIGIT 25 — Energy Recovery Wheel

0 = None
1 = Low CFM ERW w/ Bypass Defrost
2 = Standard CFM ERW w/ Bypass Defrost

DIGIT 26 — Unit Mounted Power Connection Selection

A = Terminal Block
B = Non-Fused Disconnect
C = Non-Fused Disconnect w/ Powered Convenience Outlet
D = Unit Disconnect Switch w/ high fault SCCR
E = Unit Disconnect Switch w/ high fault SCCR/ Powered Convenience Outlet

DIGIT 27 — Condenser Coil Selection

0 = Air-Cooled Aluminum
A = Evap Condenser
B = Evap Condenser w/ Sump Heater
C = Evap Condenser w/ Dolphin WaterCare System
D = Evap Condenser w/ Dolphin WaterCare System & Sump Heater
E = Evap Condenser w/ Conductivity Controller
F = Evap Condenser w/ Conductivity Controller and Sump Heater
J = Corrosion Protected Condenser Coil

DIGIT 28 — Capacity/Efficiency & Drain Pan Option

0 = Standard Evap Coil w/ Galvanized Drain Pan
A = Standard Evap Coil w/ Stainless Steel Drain Pan
B = High Cap Evap Coil w/ Galvanized Drain Pan
C = High Cap Evap Coil w/ Stainless Steel Drain Pan
V = eFlex™ w/ Std evap coil w/ Galv drain pan
W = eFlex™ w/ Std evap coil w/ SS drain pan
Y = eFlex™ w/ Hi cap evap coil w/ Galv drain pan
Z = eFlex™ w/ Hi cap evap coil w/ SS drain pan

DIGIT 29 — Refrigeration System Selection A

0 = Standard
A = Suction Service Valves
B = Replaceable Core Liquid Filter Driers
C = Suction Service Valves & Replaceable Core Liquid Filter Driers

DIGIT 30 — Refrigeration System Selection B

0 = Standard
1 = Hot Gas Reheat^(a)
2 = Hot Gas By-Pass
3 = Hot Gas Reheat^(a)/Hot Gas By-Pass
^(a) Humidity sensor required

DIGIT 31 — Ambient Control Option

0 = Standard Ambient
1 = Low Ambient

DIGIT 32 — High Duct Temp Thermostat

0 = None
1 = High Duct Temp Thermostat

DIGIT 33 — Controls Option

0 = None
1 = Remote Human Interface (RHI) & Inter-Processor Communication Bridge (IPCB)
2 = IPCB
3 = Rapid Restart

^(a) Requires CO₂ Zone Sensor(s)

^(b) Humidity sensor required



Model Number Description

DIGIT 34 — Module Options

- 0** = None
- A** = 0-5 volt Generic Building Automation System (GBAS)
- B** = 0-10 volt GBAS
- C** = 0-5 volt GBAS and 0-10 volt GBAS
- D** = Ventilation Override
- F** = LonTalk® Communication Interface (LCI)
- G** = 0-5 volt GBAS volt & Ventilation Override
- H** = 0-10 volt GBAS & Ventilation Override
- J** = 0-5 volt GBAS and 0-10 volt GBAS & Ventilation Override
- L** = LCI & Ventilation Override
- M** = BACnet Communication Interface (BCI)
- N** = BCI & Ventilation Override

DIGIT 35 — Zone Sensor Option

- 0** = None
- A** = Dual Setpoint w/Man/Auto Changeover — BAYSENS108
- B** = Dual Setpoint w/Man/Auto Chgovr & Sys Lights — BAYSENS110
- C** = Room Sensor w/timed Override & Cancel — BAYSENS073
- D** = Room Sensor w/TO (Timed Override) & Cancel & Local Stpt Adj — BAYSENS074
- G** = VAV w/System Lights — BAYSENS021
- L** = Programmable Night Setback — BAYSENS119

DIGIT 36 — Agency Approval Option

- 0** = None
- 1** = cULus

DIGIT 37 — Service Enhancements

- 0** = Single Side Access Door
- A** = Dual Side Access Door
- B** = Single Side Access Doors/ Marine Lights
- C** = Dual Side Access Doors/ Marine Lights

DIGIT 38 — Miscellaneous Options

- 0** = None
- 1** = Belt Guards
- 2** = Burglar Bars
- 3** = Belt Guards/Burglar Bars

EXAMPLE

*Model number
SXHJ10540AA715MFDE81D1100A1-
BA1000AA1A1 describes a unit with the
following characteristics: DX Cooling, No
Heat, Extended Casing, 105 Ton nominal
capacity, with 460/3/60 power supply, 3
piece construction with downflow supply and
upflow return, low CFM fans, a 60 hp supply
fan w/ a 1500 rpm drive, a 10 Hp return fan
with VFD, bypass and statitrac, with CV
control, and economizer w/ comparative
enthalpy, low leak dampers, 2" throwaway
rack less filters, terminal blank connection,
Air Cooled Copper Condenser coil, high cap
evap with galvanized drain pan, suction
service valves, hot gas reheat, 0-5V GBAS,
dual setpoint with Manual/Auto Changeover,
cULus approval, Dual side access, and belt
guards.*

*The service digit for each model number
contains 38 digits; all 38 digits must be
referenced.*



General Data

Table 6. General data (all dimensions in inches)

	90/100 Tons	105/118 Tons	120/128 Tons	130/140 Tons	150/162 Tons
Compressor Data - Fixed Speed					
Number/Size (Nominal)	4/20 Ton	2/20 Ton, 2/25 Ton	4/25 Ton	2/25 Ton, 2/32 Ton	4/32 Ton
Type	Scroll	Scroll	Scroll	Scroll	Scroll
Unit Capacity Steps	100/75/50/25	100/72/44/22	100/75/50/25	100/72/44/22	100/75/50/25
rpm	3450	3450	3450	3450	3450
No. of Circuits	2	2	2	2	2
Compressor Data - eFlex™ Variable Speed (Air-Cooled Only)					
Number/Size (Nominal)	1/6-25; 4/15	1/6-25; 3/15; 1/20	1/6-25; 2/15; 1/20; 1/25	1/6-25; 2/15; 1/25; 1/32	1/6-25; 1/15; 1/25; 2/32
Type	Scroll	Scroll	Scroll	Scroll	Scroll
Unit Capacity Steps	15-100	15-100	15-100	15-100	15-100
No. of Circuits	2	2	2	2	2
Evaporator Coil - Standard					
Dimensions	118 x 90	118 x 90	170 x 90	170 x 90	170 x 90
Size (ft ²)	73.75	73.75	106.25	106.25	106.25
Rows/Fin Series	3/168	4/168	3/168	4/168	6/168
Tube Diameter	1/2	1/2	1/2	1/2	1/2
Surface	Enhanced	Enhanced	Enhanced	Enhanced	Enhanced
Evaporator Coil - High Capacity					
Dimensions	118 x 90	118 x 90	170 x 90	170 x 90	N/A
Size (ft ²)	73.75	73.75	106.25	106.25	N/A
Rows/Fin Series	5/168	6/168	6/168	6/168	N/A
Tube Diameter	1/2	1/2	1/2	1/2	N/A
Surface	Enhanced	Enhanced	Enhanced	Enhanced	N/A
Air-Cooled - Condenser Fans					
Number/Size/Type	6/30/Prop	6/30/Prop	8/30/Prop	8/30/Prop	8/30/Prop
Hp (each)	1.5	1.5	1.5	1.5	1.5
Air-Cooled - Condenser Coil					
Size (ft ²)	134	161	161	161	161
Rows/Fin Series	1/240	1/240	2/276	2/276	2/276
Type	Microchannel	Microchannel	Microchannel	Microchannel	Microchannel
Evaporative Condenser - Condenser Fans					
Number/Type	2/Prop	2/Prop	2/Prop	2/Prop	2/Prop
hp (each)	5.4	5.4	5.4	5.4	5.4
Cycle/Phase	60/3	60/3	60/3	60/3	60/3
Evaporative Condenser - Condenser Coil					
Size (ft ²)	36	36	36	36	36
Rows	212	212	212	212	212
Tube Diameter	5/16	5/16	5/16	5/16	5/16
Evaporative Condensing Sump Pump					
Number/Type	1 / Sump, Drainage	1 / Sump, Drainage	1 / Sump, Drainage	1 / Sump, Drainage	1 / Sump, Drainage
hp	1.5	1.5	1.5	1.5	1.5
rpm	3600	3600	3600	3600	3600
Cycle/Phase	60/3	60/3	60/3	60/3	60/3
Sump Pump GPM	80	80	80	80	80
Supply Fans Standard CFM					
Number/Size/Type	1 / 36 DW AF	1 / 36 DW AF	1 / 40 DW AF	1 / 40 DW AF	1 / 40 DW AF
Number of Motors	1	1	1	1	1
hp Range	15 - 60	20 - 75	20 - 75	20 - 100	20 - 100
CFM Range	20,000 - 40,000	23,000 - 45,000	27,000 - 54,000	29,000 - 58,000	29,000 - 58,000
Total SP Range-(In. WG)	7.5	7.5	7.5	7.5	7.5
Supply Fans Low CFM					
Number/Size/Type	1/25/DW AF	1/32/DW AF	1/32/DW AF	1/32/DW AF	1/32/DW AF
Number of Motors	1	1	1	1	1
hp Range	15 - 50	15 - 60	15 - 60	20 - 60	20 - 60
CFM Range	16,000 - 31,000	19,000 - 36,000	21,000 - 42,000	23,000 - 45,000	23,000 - 45,000
ESP Range-(In. WG)	7.5	7.5	7.5	7.5	7.5
Exhaust Fans Standard CFM					
Number/Size/Type	1/28/DW FC	1/32/DW FC	1/32/DW FC	1/32/DW FC	1/32/DW FC
Number of Motors	1	1	1	1	1



General Data

Table 6. General data (all dimensions in inches) (continued)

	90/100 Tons	105/118 Tons	120/128 Tons	130/140 Tons	150/162 Tons
hp Range	10 - 50 hp	15 - 50 hp	15 - 60 hp	15 - 60 hp	15 - 60 hp
CFM Range	20,000 - 36,000	23,000 - 40,000	27,000 - 48,000	29,000 - 52,000	29,000 - 52,000
ESP Range-(In. WG)	2.5	2.5	2.5	2.5	2.5
Exhaust Fans Low CFM					
Number/Size/Type	1/25/DW FC	1/28/DW FC	1/28/DW FC	1/28/DW FC	1/28/DW FC
Number of Motors	1	1	1	1	1
hp Range	7.5 - 25 hp	7.5 - 25 hp	7.5 - 30 hp	7.5 - 50 hp	7.5 - 50 hp
CFM Range	10,000 - 28,000	12,000 - 33,000	14,000-37,000	15,000 - 41,000	15,000 - 41,000
ESP Range-(In. WG)	2.5	2.5	2.5	2.5	2.5
Return Fans Standard CFM					
Number/Size/Type	1/40/Plenum AF	1/40/Plenum AF	1/44/Plenum AF	1/44/Plenum AF	1/44/Plenum AF
Number of Motors	1	1	1	1	1
hp Range	10 - 30 hp	15 - 40 hp	15 - 40 hp	20 - 50 hp	20 - 50 hp
CFM Range	20,000 - 40,000	24,000 - 44,000	27,000 - 51,000	29,000 - 54,000	29,000 - 54,000
ESP Range-(In. WG)	2.5	2.5	2.5	2.5	2.5
Return Fans Low CFM					
Number/Size/Type	1/36.5/Plenum	1/36.5/Plenum	1/36.5/Plenum	1/36.5/Plenum	1/36.5/Plenum
Number of Motors	1	1	1	1	1
hp Range	7.5 - 20 hp	10 - 25 hp	10 - 40 hp	15 - 40 hp	15 - 40 hp
CFM Range	16,000 - 28,000	19,000 - 33,000	21,000 - 36,000	23,000 - 36,000	23,000 - 36,000
ESP Range-(In. WG)	2.5	2.5	2.5	2.5	2.5
Energy Recovery Standard CFM					
Cassette Dimensions (LxWxH)	104 x 104 x 10	108 x 108 x 14	115 x 115 x 14	115 x 115 x 14	115 x 115 x 14
Wheel Segments	16	16	16	16	16
Motor (V/ph/Hz)	460/3/60 575/3/60	460/3/60 575/3/60	460/3/60 575/3/60	460/3/60 575/3/60	460/3/60 575/3/60
hp	0.33	0.33	0.33	0.33	0.33
Galv. Steel RA Filters - Number/Size	10/24 x 24 x1	10/24 x 24 x1	10/24 x 24 x1	10/24 x 24 x1	10/24 x 24 x1
Galv. Steel FA Filters - Number/Size	8/24 x 24 x1	8/24 x 24 x1	8/24 x 24 x1	8/24 x 24 x1	8/24 x 24 x1
CFM Range	8,500 - 18,000	9,000 - 21,000	10,000 - 24,000	13,000 - 29,000	13,000 - 29,000
Energy Recovery Low CFM					
Cassette Dimensions (LxWxH)	85 x 85 x 7.07	85 x 85 x 7.07	91 x 91 x 10	96 x 96 x 10	96 x 96 x 10
Wheel Segments	8	8	8	16	16
Motor (V/ph/Hz)	460/3/60 575/3/60	460/3/60 575/3/60	460/3/60 575/3/60	460/3/60 575/3/60	460/3/60 575/3/60
hp	0.25	0.25	0.25	0.33	0.33
Galv. Steel RA Filters - Number/Size	10/24 x 24 x1	10/24 x 24 x1	10/24 x 24 x1	10/24 x 24 x1	10/24 x 24 x1
Galv. Steel FA Filters - Number/Size	8/24 x 24 x1	8/24 x 24 x1	6/24 x 24 x1 2/12 x 24 x1	6/24 x 24 x1 2/12 x 24 x1	6/24 x 24 x1 2/12 x 24 x1
CFM Range	8,500 - 14,000	9,000 - 14,000	9,000 - 15,000	9,000 - 16,000	9,000 - 16,000
Electric Heat (60 Hz)					
kW	90-265	90-265	140-300	140-300	140-300
Circuit Capacity Steps	30 - 37.5 kW	30 - 37.5 kW	35 - 37.5 kW	35 - 37.5 kW	35 - 37.5 kW
Electric Heat (50 Hz)					
kW	56-166	56-166	88-188	88-188	88-188
Circuit Capacity Steps	18.8 - 23.5 kW	18.8 - 23.5 kW	21.9 - 23.5 kW	21.9 - 23.5 kW	21.9 - 23.5 kW
Natural Gas Heat					
2-Stage Gas Heat					
Low Heat Input (mbh)	850	850	1100	1100	1100
Mid Heat Input (mbh)	1100	1100	1800	1800	1800
High Heat Input (mbh)	1800	1800	2500	2500	2500
Fully Modulating Steps					
Low Heat Input (mbh)	10:1	10:1	20:1	20:1	20:1
Mid Heat Input (mbh)	20:1	20:1	20:1	20:1	20:1
High Heat Input (mbh)	20:1	20:1	20:1	20:1	20:1
Heat Exchanger Material	Stainless Steel	Stainless Steel	Stainless Steel	Stainless Steel	Stainless Steel
Gas Heat Steady State Efficiency%^(a)					
	80%	80%	80%	80%	80%
Hot Water Coil					
Size	33 x 88 x 2 rows	33 x 88 x 2 rows	33 x 110 x 2 rows	33 x 110 x 2 rows	33 x 110 x 2 rows
Quantity	2	2	2	2	2
Type	5W, PrimaFlo	5W, PrimaFlo	5W, PrimaFlo	5W, PrimaFlo	5W, PrimaFlo
High Heat (fins/ft)	122	122	122	122	122
Low Heat (fins/ft)	80	80	80	80	80

Table 6. General data (all dimensions in inches) (continued)

	90/100 Tons	105/118 Tons	120/128 Tons	130/140 Tons	150/162 Tons
Steam Coil					
Size	33 x 88 x 1 rows	33 x 88 x 1 rows	33 x 110 x 1 rows	33 x 110 x 1 rows	33 x 110 x 1 rows
Quantity	2	2	2	2	2
Type	NS, SigmaFlo	NS, SigmaFlo	NS, SigmaFlo	NS, SigmaFlo	NS, SigmaFlo
High Heat (fins/ft)	112	112	112	112	112
Low Heat (fins/ft)	62	62	62	62	62
Filters					
Standard 2" High Efficiency Throwaway Filters					
Number/Size	21-20 x 24 x 2 5-12 x 24 x 2	21-20 x 24 x 2 5-12 x 24 x 2	28-20 x 24 x 2	28-20 x 24 x 2	28-20 x 24 x 2
Face area (ft ²)	80	80	93	93	93
90-95% Bag Filters w/Prefilters					
Number/Size	21-20 x 24 x 19 5-12 x 24 x 19	21-20 x 24 x 19 5-12 x 24 x 19	21-20 x 24 x 19 5-12 x 24 x 19	21-20 x 24 x 19 5-12 x 24 x 19	21-20 x 24 x 19 5-12 x 24 x 19
Face area (ft ²)	80	80	80	80	80
Prefilters					
Number/Size	21-20 x 24 x 2 5-12 x 24 x 2	21-20 x 24 x 2 5-12 x 24 x 2	21-20 x 24 x 2 5-12 x 24 x 2	21-20 x 24 x 2 5-12 x 24 x 2	21-20 x 24 x 2 5-12 x 24 x 2
90-95% Cartridge Filters w/Prefilters					
Number/Size	21-20 x 24 x 12 5-12 x 24 x 12	21-20 x 24 x 12 5-12 x 24 x 12	21-20 x 24 x 12 5-12 x 24 x 12	21-20 x 24 x 12 5-12 x 24 x 12	21-20 x 24 x 12 5-12 x 24 x 12
Face area (ft ²)	80	80	80	80	80
Prefilters					
Number/Size	21-20 x 24 x 2 5-12 x 24 x 2	21-20 x 24 x 2 5-12 x 24 x 2	21-20 x 24 x 2 5-12 x 24 x 2	21-20 x 24 x 2 5-12 x 24 x 2	21-20 x 24 x 2 5-12 x 24 x 2
90-95% Low Pressure Drop Cartridge Filters w/Prefilters					
Number/Size	21-20 x 24 x 12 5-12 x 24 x 12	21-20 x 24 x 12 5-12 x 24 x 12	21-20 x 24 x 12 5-12 x 24 x 12	21-20 x 24 x 12 5-12 x 24 x 12	21-20 x 24 x 12 5-12 x 24 x 12
Face area (ft ²)	80	80	80	80	80
Prefilters					
Number/Size	21-20 x 24 x 2 5-12 x 24 x 2	21-20 x 24 x 2 5-12 x 24 x 2	21-20 x 24 x 4 5-12 x 24 x 4	21-20 x 24 x 4 5-12 x 24 x 4	21-20 x 24 x 4 5-12 x 24 x 4
Final Filters					
90-95% Low Pressure Drop Cartridge Filters w/Prefilters^(b)					
Number/Size	15-24 x 24 x 12 7-12 x 24 x 12	15-24 x 24 x 12 7-12 x 24 x 12	15-24 x 24 x 12 7-12 x 24 x 12	15-24 x 24 x 12 7-12 x 24 x 12	15-24 x 24 x 12 7-12 x 24 x 12
Face area (ft ²)	74	74	74	74	74
Prefilters					
Number/Size	15-24 x 24 x 4 7-12 x 24 x 4	15-24 x 24 x 4 7-12 x 24 x 4	15-24 x 24 x 4 7-12 x 24 x 4	15-24 x 24 x 4 7-12 x 24 x 4	15-24 x 24 x 4 7-12 x 24 x 4
90-95% Bag Filters w/Prefilters^(c)					
Number/Size	15-24 x 24 x 19 7-12 x 24 x 19	15-24 x 24 x 19 7-12 x 24 x 19	15-24 x 24 x 19 7-12 x 24 x 19	15-24 x 24 x 19 7-12 x 24 x 19	15-24 x 24 x 19 7-12 x 24 x 19
Face area (ft ²)	74	74	74	74	74
Prefilters					
Number/Size	15-24 x 24 x 2 7-12 x 24 x 2	15-24 x 24 x 2 7-12 x 24 x 2	15-24 x 24 x 2 7-12 x 24 x 2	15-24 x 24 x 2 7-12 x 24 x 2	15-24 x 24 x 2 7-12 x 24 x 2
90-95% Cartridge Filters^(c)					
Number/Size	15-24 x 24 x 12 7-12 x 24 x 12	15-24 x 24 x 12 7-12 x 24 x 12	15-24 x 24 x 12 7-12 x 24 x 12	15-24 x 24 x 12 7-12 x 24 x 12	15-24 x 24 x 12 7-12 x 24 x 12
Face area (ft ²)	74	74	74	74	74
Prefilters					
Number/Size	15-24 x 24 x 2 7-12 x 24 x 2	15-24 x 24 x 2 7-12 x 24 x 2	15-24 x 24 x 2 7-12 x 24 x 2	15-24 x 24 x 2 7-12 x 24 x 2	15-24 x 24 x 2 7-12 x 24 x 2
90-95% High Temp Cartridge Filters^(d)					
Number/Size	15-24 x 24 x 12 7-12 x 24 x 12	15-24 x 24 x 12 7-12 x 24 x 12	15-24 x 24 x 12 7-12 x 24 x 12	15-24 x 24 x 12 7-12 x 24 x 12	15-24 x 24 x 12 7-12 x 24 x 12
Face area (ft ²)	74	74	74	74	74
Prefilters					
Number/Size	15-24 x 24 x 2 7-12 x 24 x 2	15-24 x 24 x 2 7-12 x 24 x 2	15-24 x 24 x 2 7-12 x 24 x 2	15-24 x 24 x 2 7-12 x 24 x 2	15-24 x 24 x 2 7-12 x 24 x 2
HEPA Filters w/Prefilters^(c)					
Number/Size	15-24 x 24 x 12 7-12 x 24 x 12	15-24 x 24 x 12 7-12 x 24 x 12	15-24 x 24 x 12 7-12 x 24 x 12	15-24 x 24 x 12 7-12 x 24 x 12	15-24 x 24 x 12 7-12 x 24 x 12
Face area (ft ²)	74	74	74	74	74
Prefilters					
Number/Size	15-24 x 24 x 2 7-12 x 24 x 2	15-24 x 24 x 2 7-12 x 24 x 2	15-24 x 24 x 2 7-12 x 24 x 2	15-24 x 24 x 2 7-12 x 24 x 2	15-24 x 24 x 2 7-12 x 24 x 2
High Temp HEPA Cartridge Filters w/Prefilters^(d)					



General Data

Table 6. General data (all dimensions in inches) (continued)

	90/100 Tons	105/118 Tons	120/128 Tons	130/140 Tons	150/162 Tons
Number/Size	15-24 x 24 x 12 7-12 x 24 x 12	15-24 x 24 x 12 7-12 x 24 x 12	15-24 x 24 x 12 7-12 x 24 x 12	15-24 x 24 x 12 7-12 x 24 x 12	15-24 x 24 x 12 7-12 x 24 x 12
Face area (ft ²)	74	74	74	74	74
Prefilters					
Number/Size	15-24 x 24 x 2 7-12 x 24 x 2	15-24 x 24 x 2 7-12 x 24 x 2	15-24 x 24 x 2 7-12 x 24 x 2	15-24 x 24 x 2 7-12 x 24 x 2	15-24 x 24 x 2 7-12 x 24 x 2
Standard Unit Minimum Outside Air Temperature for Mechanical Cooling					
Without Hot Gas Bypass	40	40	40	40	40
With Hot Gas Bypass	55	55	55	55	55
Low Unit Minimum Outside Air Temperature for Mechanical Cooling					
Without Hot Gas Bypass	0	0	0	0	0
With Hot Gas Bypass	10	10	10	10	10
Evaporative Condenser Minimum Outside Temperature for Mechanical Cooling					
Without Sump Heater	40	40	40	40	40
With Sump Heater	10	10	10	10	10

Note: Air-Cooled/Evaporative Condensers - please note that not all data applies to both models.

- (a) Heating Performance is AHRI and DOE certified
- (b) Standard airflow applications of cooling only units require High Efficiency Throwaway Prefilters with the 90-95% Low PD Cartridge Filter Option.
- (c) Standard airflow applications of cooling only units include 2" High Efficiency Throwaway Prefilters with the 90-95% Bag and HEPA Filter Options.
- (d) Gas/Electric Units require 2" High Efficiency High Temperature Rated Throwaway Prefilters with High Temperature Rated 90-95% Cartridge and HEPA filter options.

Table 7. Gas heat inputs/input ranges/inlet sizes

Two-Stage Gas Heat				
Standard Gas Heat Input (MBh)	Low Gas Heat Inputs (MBh)	High Fire Heat Input (MBh)	Modulating Gas Heat Range (MBh)	Gas Heat Inlet Sizes (in.)
850	425	850	85-850	1
1100	550	1100	55-1100	1 1/4
1800	900	1800	90-1800	1 1/2
2500	1250	2500	125-2500	1 1/2

Table 8. Economizer outdoor air damper leakage (at rated airflow)³

Damper	Leakage Rate/CFM/ft²
Standard	20
Optional "Low Leak"	10 (Class 2 AMCA 511-99)
Optional "Ultra Low Leak"	4 (Class 1 AMCA 511-99)
Title 24 Ultra Low Leak	3 (Class 1A AMCA 511-99)

³ Leakage/ft² at 1.0 in WC pressure difference



Performance Adjustment Factors

Figure 24. Air density ratios

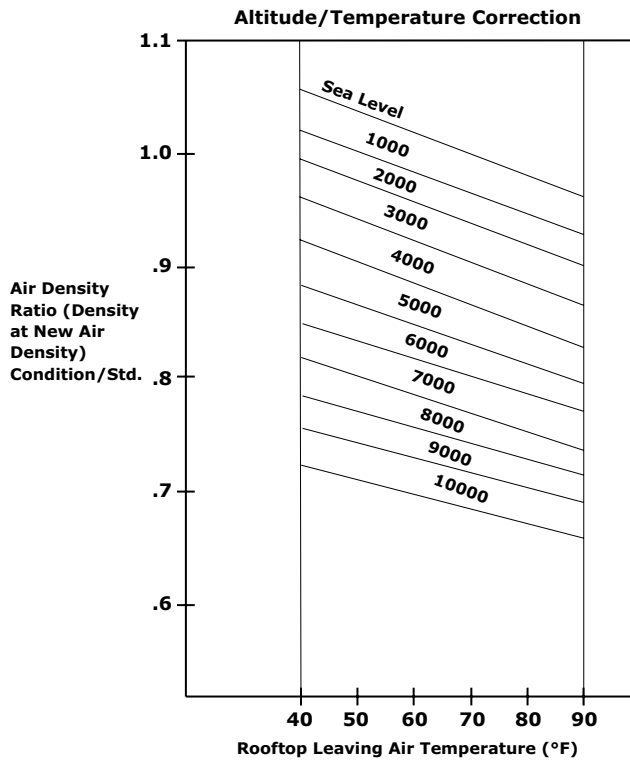

Table 9. Enthalpy of saturated air

Wet Bulb Temperature	Btu per Pound
41	15.70
43	16.66
42	16.17
43	16.66
44	17.15
45	17.65
46	18.16
47	18.68
48	19.21
49	19.75
50	20.30
51	20.86
52	21.44
53	22.02
54	22.62
55	23.22
56	23.84



Performance Adjustment Factors

Table 9. Enthalpy of saturated air (continued)

Wet Bulb Temperature	Btu per Pound
57	24.48
58	25.12
59	25.78
60	26.46
61	27.15
62	27.85
63	28.57
64	29.31
65	30.06
66	30.83
67	31.62
68	32.42
69	33.25
70	34.09
71	34.95
72	35.83
73	36.74
74	37.66

Table 10. Cooling capacity altitude correction factors

	Altitude (ft.)							
	Sea Level	1000	2000	3000	4000	5000	6000	7000
Cooling Capacity Multiplier	1.00	0.99	0.99	0.98	0.97	0.96	0.95	0.94
KW Correction Multiplier (Compressors)	1.00	1.01	1.02	1.03	1.04	1.05	1.06	1.07
Sensible Heat Ratio Correction Multiplier	1.00	.98	.95	.93	.91	.89	.87	.85
Maximum Condenser Ambient	115°F	114°F	113°F	112°F	111°F	110°F	109°F	108°F

Table 11. Gas heating capacity altitude correction factors

	Sea Level to 2000	2001 to 2500	2501 to 3500	3501 to 4500	4501 to 5500	5501 to 6500	6501 to 7500
Capacity Multiplier	1.00	.92	.88	.84	.80	.76	.72



Performance Data

Gross Cooling Capacities

Air-Cooled, 60Hz, Standard and High Capacity Evaporator Coils

Table 12. Gross cooling capacities – 90 tons – standard evaporator coil, 60Hz

CFM	Ent DB (°F)	Ambient Temperature (°F)																							
		85				95				105				115											
		Entering Wet Bulb (°F)		73		Entering Wet Bulb (°F)		73		Entering Wet Bulb (°F)		67		73		Entering Wet Bulb (°F)		61		67		73			
16000	75	904	650	998	532	1097	412	869	631	959	514	1054	394	831	611	917	494	1008	375	793	591	874	474	962	356
	80	906	739	1000	625	1098	503	871	719	962	606	1055	485	835	698	920	586	1009	466	797	677	877	566	963	447
	85	914	830	1003	717	1100	594	879	810	962	698	1058	576	843	789	921	677	1012	556	806	768	878	655	966	537
	90	923	923	1005	805	1102	685	894	894	967	785	1060	667	863	863	926	763	1014	647	831	831	884	741	969	628
20000	75	957	719	1052	575	1150	428	918	697	1009	556	1103	407	876	675	963	535	1053	388	834	653	916	515	1003	369
	80	964	828	1055	688	1151	538	926	807	1013	669	1105	519	885	785	964	649	1056	500	843	762	919	627	1006	481
	85	977	942	1057	797	1154	650	932	932	1015	777	1107	629	897	897	970	755	1059	612	860	860	924	732	1009	592
	90	1010	1010	1065	906	1155	763	977	977	1023	885	1108	743	941	941	978	863	1060	722	903	903	933	840	1011	701
25000	75	1004	804	1098	623	1193	439	962	773	1051	603	1143	423	918	750	1002	582	1091	402	872	726	953	561	1036	385
	80	1016	931	1100	759	1195	578	975	909	1054	737	1146	559	932	886	1005	715	1094	540	878	878	956	692	1041	520
	85	1041	1041	1106	890	1198	715	1005	1005	1062	869	1148	697	966	966	1013	846	1096	678	925	925	965	823	1042	656
	90	1091	1091	1118	1025	1200	847	1053	1053	1074	1003	1152	826	1012	1012	1027	980	1101	805	972	972	971	971	1047	782
30000	75	1039	866	1129	667	1222	451	995	843	1078	648	1170	433	948	819	1026	625	1116	414	900	794	976	602	1059	394
	80	1047	1047	1132	822	1226	614	1008	1008	1085	800	1175	596	967	967	1034	776	1121	577	924	924	983	753	1064	556
	85	1099	1099	1142	978	1227	774	1059	1059	1095	956	1177	754	1016	1016	1045	932	1123	732	974	974	995	909	1067	709
	90	1150	1150	1150	1150	1232	926	1110	1110	1109	1109	1182	905	1066	1066	1066	1066	1129	883	1021	1021	1021	1021	1073	859
33000	75	1056	906	1141	692	1236	458	1011	883	1092	670	1183	440	963	859	1039	647	1128	420	914	833	988	624	1070	401
	80	1073	1073	1148	858	1239	636	1033	1033	1099	835	1188	617	990	990	1048	812	1133	598	947	947	996	788	1074	579
	85	1127	1127	1159	1028	1242	806	1086	1086	1111	1006	1190	785	1042	1042	1061	982	1136	763	997	997	1010	958	1078	740
	90	1179	1179	1179	1179	1247	971	1137	1137	1136	1136	1196	951	1092	1092	1092	1092	1142	928	1045	1045	1044	1044	1085	904
36000	75	1070	946	1154	713	1248	464	1024	922	1104	691	1194	446	976	897	1051	668	1138	427	927	872	998	644	1079	407
	80	1097	1097	1161	893	1251	657	1055	1055	1112	870	1199	638	1010	1010	1060	846	1141	621	966	966	1007	822	1082	598
	85	1151	1151	1174	1077	1253	837	1108	1108	1126	1055	1201	816	1063	1063	1076	1031	1146	794	1017	1017	1024	1006	1087	770
	90	1204	1204	1203	1203	1259	1016	1160	1160	1160	1160	1208	995	1114	1114	1114	1114	1153	972	1064	1064	1064	1064	1095	948
40000	75	1087	996	1168	740	1261	473	1041	972	1117	718	1207	454	980	980	1063	694	1149	435	934	934	1010	670	1089	415
	80	1123	1123	1176	938	1263	686	1080	1080	1126	915	1209	666	1034	1034	1073	891	1153	643	988	988	1019	866	1093	620
	85	1178	1178	1192	1141	1266	877	1134	1134	1143	1118	1214	856	1088	1088	1093	1091	1157	833	1039	1039	1040	1040	1097	809
	90	1231	1231	1231	1231	1274	1074	1187	1187	1186	1186	1222	1053	1138	1138	1138	1138	1166	1029	1086	1086	1086	1086	1106	1004

Table 13. Gross cooling capacities – 90 tons eFlex™ variable speed – standard evaporator coil, 60Hz

CFM	Ent DB (°F)	Ambient Temperature (°F)																																																																																																		
		85						95						105						115																																																																																
		Entering Wet Bulb (°F)			73			67			61			73			67			61			73			67			61			73																																																																				
		CAP	SHC	SHC	CAP	SHC	SHC	CAP	SHC	SHC	CAP	SHC	SHC	CAP	SHC	SHC	CAP	SHC	SHC	CAP	SHC	SHC	CAP	SHC	SHC	CAP	SHC	SHC	CAP	SHC	SHC																																																																					
16000	75	909	652	1006	536	1105	415	869	631	962	515	1057	395	837	614	917	494	1005	373	818	603	877	475	952	351	80	911	742	1009	629	1106	507	873	720	965	607	1057	486	840	701	920	586	1006	464	820	690	879	566	953	442	85	918	833	1011	721	1108	598	881	811	967	699	1060	577	847	791	923	676	1009	555	824	782	880	655	956	533	90	933	915	1013	809	1110	689	895	895	971	786	1062	667	865	865	926	763	1011	645	840	840	885	742	958	623
	75	964	722	1062	579	1153	427	920	699	1013	557	1100	406	879	676	962	534	1043	384	846	658	914	513	984	361	80	971	833	1064	693	1154	539	929	809	1016	671	1102	518	886	786	965	647	1045	496	851	766	915	625	986	473	85	982	943	1067	802	1157	651	942	914	1019	779	1105	630	902	884	969	754	1048	607	864	864	920	730	988	583	90	1018	1018	1074	911	1158	762	980	980	1027	887	1106	740	940	940	977	862	1049	717	902	902	928	837	989	691
	75	1014	800	1106	627	1188	437	966	775	1054	604	1131	416	918	750	999	580	1069	394	876	727	943	558	1005	370	80	1026	937	1108	763	1189	575	974	918	1057	739	1133	554	929	886	1002	713	1071	531	887	855	948	687	1006	507	85	1050	1050	1115	894	1190	713	1009	1009	1064	870	1134	690	964	964	1010	844	1072	665	921	921	955	818	1007	640	90	1098	1098	1118	1040	1191	843	1056	1056	1071	1008	1135	819	1009	1009	1020	973	1073	793	961	961	968	937	1008	765
	30000	75	1049	871	1135	670	1209	447	1000	845	1080	646	1149	425	948	818	1021	622	1084	402	900	794	963	596	1017	379	80	1065	1023	1139	825	1211	609	1018	990	1085	800	1151	587	965	965	1028	773	1086	564	920	920	969	746	1017	541	85	1107	1107	1147	980	1213	769	1062	1062	1094	955	1152	744	1013	1013	1037	928	1087	717	963	963	978	900	1018	689	90	1153	1153	1161	1118	1218	920	1106	1106	1105	1105	1155	894	1054	1054	1053	1053	1089	866	997	997	996	996	1019
75		1066	912	1148	693	1220	452	1015	885	1091	670	1158	431	962	858	1032	643	1092	408	912	832	973	616	1023	384	80	1082	1082	1152	860	1223	630	1037	1037	1097	835	1160	610	988	988	1039	808	1093	585	940	940	979	780	1023	559	85	1133	1133	1161	1029	1225	800	1085	1085	1107	1004	1161	774	1035	1035	1049	976	1093	746	981	981	988	947	1023	717	90	1176	1176	1175	1175	1231	965	1126	1126	1125	1125	1167	938	1069	1069	1069	1069	1098	910	1008	1008	1007	1007	1025	879
75		1081	951	1158	715	1229	458	1029	924	1102	690	1166	436	969	907	1042	663	1098	413	920	871	980	636	1028	389	80	1105	1105	1163	894	1231	651	1058	1058	1108	868	1167	627	1007	1007	1048	841	1099	605	956	956	986	812	1028	576	85	1154	1154	1173	1077	1235	830	1105	1105	1118	1051	1170	803	1051	1051	1059	1019	1100	775	993	993	997	976	1027	745	90	1194	1194	1194	1194	1243	1010	1141	1141	1140	1140	1177	982	1082	1082	1081	1081	1106	952	1017	1017	1016	1016	1027	944
40000		75	1091	1014	1169	741	1238	465	1040	978	1113	716	1174	443	987	941	1051	689	1105	420	929	929	988	660	1033	396	80	1129	1129	1174	937	1243	675	1080	1080	1118	912	1174	652	1028	1028	1057	883	1105	625	973	973	994	854	1033	596	85	1175	1175	1185	1134	1247	870	1124	1124	1130	1095	1180	842	1067	1067	1069	1052	1108	813	1004	1004	1005	1005	1032	782	90	1219	1219	1219	1219	1258	1068	1161	1161	1161	1161	1181	1069	1099	1099	1098	1098	1111	1025	1030	1030	1030	1030	1036

Table 14. Gross cooling capacities – 105 tons – standard evaporator coil, 60Hz

CFM	Ent DB (°F)	Ambient Temperature (°F)																							
		85						95						105						115					
		Entering Wet Bulb (°F)						Entering Wet Bulb (°F)						Entering Wet Bulb (°F)						Entering Wet Bulb (°F)					
		61	67	73	79	85	91	61	67	73	79	85	91	61	67	73	79	85	91	61	67	73	79	85	91
19000	75	1061	771	1169	627	1280	479	1018	748	1121	605	1230	458	972	724	1072	582	1177	437	925	698	1024	560	1120	414
	80	1065	880	1172	739	1282	590	1023	856	1125	717	1232	569	978	830	1076	694	1179	547	933	806	1028	671	1123	525
	85	1075	991	1175	851	1284	701	1033	967	1126	828	1235	680	989	941	1078	803	1182	658	945	916	1030	779	1126	635
	90	1095	1095	1179	958	1287	811	1059	1059	1133	934	1238	790	1020	1020	1085	910	1185	767	982	982	1037	885	1129	744
23000	75	1111	840	1220	670	1329	492	1065	815	1169	647	1276	471	1015	788	1117	624	1218	449	968	764	1064	601	1157	426
	80	1121	971	1224	804	1332	625	1075	945	1173	781	1279	604	1026	919	1122	758	1222	582	980	893	1068	734	1161	558
	85	1136	1105	1227	933	1335	757	1092	1080	1177	908	1282	736	1045	1045	1126	883	1225	713	1004	1004	1073	858	1165	690
	90	1179	1179	1236	1061	1337	889	1139	1139	1187	1037	1283	868	1097	1097	1136	1012	1226	843	1054	1054	1083	985	1166	817
28000	75	1159	919	1264	718	1372	506	1110	893	1212	696	1315	485	1058	866	1156	672	1254	463	1008	840	1099	648	1190	440
	80	1173	1077	1268	879	1375	665	1124	1051	1214	851	1319	644	1074	1024	1160	826	1258	622	1025	997	1103	799	1194	598
	85	1204	1204	1275	1028	1378	824	1160	1160	1224	1004	1322	803	1116	1116	1169	978	1260	781	1069	1069	1112	951	1196	754
	90	1259	1259	1288	1184	1380	977	1216	1216	1238	1160	1325	953	1170	1170	1184	1133	1265	928	1120	1120	1128	1106	1201	901
33000	75	1195	993	1296	764	1402	518	1143	966	1242	742	1343	497	1091	939	1181	718	1280	475	1038	911	1122	691	1213	452
	80	1214	1179	1300	941	1406	704	1158	1158	1247	917	1347	683	1112	1112	1189	890	1284	660	1064	1064	1129	862	1217	636
	85	1263	1263	1311	1120	1407	886	1217	1217	1258	1095	1349	863	1169	1169	1201	1068	1286	837	1118	1118	1141	1040	1219	809
	90	1321	1321	1320	1320	1412	1059	1274	1274	1274	1274	1354	1035	1224	1224	1224	1224	1292	1009	1170	1170	1169	1169	1225	981
38000	75	1223	1064	1318	806	1425	530	1170	1036	1262	781	1365	509	1116	1009	1203	755	1299	487	1061	980	1141	727	1231	463
	80	1249	1249	1326	1004	1428	741	1202	1202	1271	979	1368	720	1152	1152	1212	952	1303	697	1100	1100	1150	923	1233	674
	85	1309	1309	1340	1208	1430	941	1262	1262	1286	1183	1370	917	1211	1211	1227	1155	1305	891	1155	1155	1165	1126	1237	863
	90	1368	1368	1368	1368	1437	1139	1319	1319	1319	1319	1377	1114	1265	1265	1265	1265	1312	1088	1207	1207	1206	1206	1243	1059
43000	75	1246	1132	1338	843	1443	541	1192	1104	1281	817	1381	520	1137	1076	1220	790	1315	498	1081	1046	1156	761	1244	474
	80	1285	1285	1347	1065	1445	781	1236	1236	1290	1039	1383	757	1185	1185	1230	1011	1317	731	1130	1130	1166	982	1247	703
	85	1347	1347	1364	1294	1447	995	1297	1297	1308	1268	1387	970	1243	1243	1249	1240	1321	943	1185	1185	1187	1187	1250	915
	90	1406	1406	1405	1405	1457	1217	1354	1354	1354	1354	1394	1191	1297	1297	1297	1297	1328	1164	1236	1236	1235	1235	1258	1135
45000	75	1254	1158	1345	857	1449	545	1200	1131	1287	831	1387	524	1145	1102	1225	804	1320	502	1081	1081	1161	775	1249	479
	80	1297	1297	1354	1089	1451	793	1248	1248	1297	1063	1389	768	1196	1196	1236	1035	1323	742	1140	1140	1171	1005	1252	714
	85	1360	1360	1372	1327	1454	1016	1309	1309	1317	1301	1392	991	1254	1254	1257	1257	1326	964	1195	1195	1195	1195	1255	935
	90	1419	1419	1419	1419	1464	1248	1366	1366	1366	1366	1400	1222	1308	1308	1308	1308	1334	1194	1246	1246	1245	1245	1264	1164

Table 15. Gross cooling capacities – 105 tons eFlex™ variable speed – standard evaporator coil, 60Hz

CFM	Ent DB (°F)	Ambient Temperature (°F)																							
		85						95						105						115					
		Entering Wet Bulb (°F)						Entering Wet Bulb (°F)						Entering Wet Bulb (°F)						Entering Wet Bulb (°F)					
		61	67	73	79	85	91	61	67	73	79	85	91	61	67	73	79	85	91	61	67	73	79	85	91
19000	75	1060	769	1168	626	1274	475	1013	744	1115	601	1218	452	969	722	1062	576	1158	428	942	706	1017	555	1097	404
	80	1064	879	1172	738	1275	586	1018	852	1119	713	1220	563	974	828	1066	688	1160	539	944	811	1020	666	1100	514
	85	1075	990	1175	850	1278	697	1028	963	1120	824	1223	673	984	938	1068	797	1163	649	952	919	1022	776	1102	624
	90	1095	1095	1179	957	1280	807	1055	1055	1128	931	1225	783	1014	1014	1075	904	1166	758	981	981	1028	879	1104	733
23000	75	1110	839	1218	668	1315	486	1059	811	1161	642	1256	463	1009	784	1104	617	1191	438	972	764	1051	594	1125	413
	80	1121	970	1222	802	1317	618	1070	942	1165	776	1258	595	1019	914	1107	750	1194	570	980	893	1053	725	1127	544
	85	1137	1105	1225	931	1320	750	1087	1072	1169	904	1260	727	1038	1038	1113	876	1196	701	1000	1000	1059	850	1128	675
	90	1179	1179	1234	1060	1321	882	1134	1134	1179	1032	1261	857	1088	1088	1123	1004	1196	829	1044	1044	1067	977	1129	800
28000	75	1159	918	1259	715	1348	496	1103	889	1200	690	1285	473	1048	860	1139	664	1217	448	1004	837	1080	640	1146	423
	80	1173	1076	1262	873	1349	655	1119	1047	1203	845	1286	631	1064	1018	1143	817	1218	606	1016	991	1083	789	1146	580
	85	1203	1203	1269	1025	1351	813	1154	1154	1212	997	1287	790	1105	1105	1151	969	1218	763	1057	1057	1090	939	1146	732
	90	1256	1256	1281	1180	1354	965	1207	1207	1224	1153	1288	937	1154	1154	1161	1126	1218	907	1099	1099	1102	1082	1144	876
33000	75	1194	992	1287	760	1370	506	1136	962	1226	735	1304	483	1079	932	1161	707	1233	458	1028	906	1098	679	1160	433
	80	1210	1182	1291	936	1374	692	1152	1152	1232	909	1304	667	1101	1101	1168	879	1231	640	1051	1051	1103	850	1157	614
	85	1259	1259	1300	1114	1376	873	1207	1207	1241	1086	1305	844	1153	1153	1177	1056	1232	814	1096	1096	1112	1025	1156	782
	90	1309	1309	1308	1308	1382	1046	1255	1255	1255	1255	1310	1016	1195	1195	1195	1195	1233	984	1130	1130	1130	1130	1155	951
38000	75	1221	1062	1306	800	1388	517	1162	1032	1245	773	1317	492	1103	1001	1179	743	1245	467	1048	973	1113	713	1170	442
	80	1245	1245	1312	998	1392	728	1192	1192	1251	969	1318	702	1138	1138	1185	939	1243	675	1082	1082	1118	908	1167	647
	85	1299	1299	1323	1200	1395	927	1245	1245	1262	1171	1320	897	1186	1186	1196	1140	1242	864	1122	1122	1127	1106	1163	832
	90	1347	1347	1346	1346	1403	1125	1286	1286	1286	1286	1328	1094	1221	1221	1220	1220	1248	1060	1149	1149	1148	1148	1165	1025
43000	75	1242	1130	1322	835	1403	527	1182	1099	1259	807	1329	502	1122	1068	1192	777	1253	477	1063	1035	1124	746	1178	452
	80	1278	1278	1328	1056	1405	765	1224	1224	1266	1028	1329	735	1165	1165	1198	996	1252	704	1105	1105	1128	964	1173	672
	85	1329	1329	1339	1282	1411	980	1271	1271	1277	1252	1334	948	1207	1207	1209	1205	1252	915	1138	1138	1138	1138	1169	880
	90	1380	1380	1379	1379	1422	1203	1314	1314	1313	1313	1342	1170	1242	1242	1242	1242	1260	1135	1165	1165	1164	1164	1171	1110
45000	75	1250	1156	1328	849	1407	531	1190	1125	1264	821	1333	506	1126	1095	1196	790	1256	480	1066	1066	1127	759	1181	456
	80	1289	1289	1333	1079	1410	776	1234	1234	1270	1050	1334	746	1174	1174	1202	1019	1255	714	1112	1112	1131	986	1176	682
	85	1338	1338	1347	1315	1416	1000	1279	1279	1282	1277	1338	969	1213	1213	1214	1214	1256	935	1143	1143	1142	1142	1171	899
	90	1392	1392	1391	1391	1429	1233	1324	1324	1323	1323	1348	1200	1250	1250	1250	1250	1263	1164	1170	1170	1170	1170	1174	1127

Table 16. Gross cooling capacities – 120 tons – standard evaporator coil, 60Hz

CFM	Ent DB (°F)	Ambient Temperature (°F)																								
		85				95				105				115												
		Entering Wet Bulb (°F)		73		61		67		61		67		73		61		67		73						
		CAP	SHC	CAP	SHC	CAP	SHC	CAP	SHC	CAP	SHC	CAP	SHC	CAP	SHC	CAP	SHC	CAP	SHC	CAP	SHC					
21000	75	1160	838	1287	688	1425	534	1117	815	1240	665	1373	513	1070	790	1188	640	1316	489	1019	763	1132	615	1254	464	
	80	1162	957	1290	808	1425	653	1120	933	1243	785	1374	631	1073	907	1191	760	1317	607	1024	880	1136	734	1255	582	
	85	1173	1077	1293	928	1427	772	1132	1053	1247	905	1376	750	1086	1027	1195	880	1319	726	1038	999	1136	854	1258	700	
	90	1189	1189	1295	1046	1430	890	1154	1154	1249	1022	1379	868	1115	1115	1198	996	1323	844	1073	1073	1144	968	1262	818	
26000	75	1228	927	1357	742	1494	553	1180	903	1305	718	1438	530	1126	875	1248	693	1376	506	1071	846	1187	666	1308	480	
	80	1236	1071	1361	888	1495	698	1190	1046	1310	865	1439	675	1139	1019	1253	839	1377	651	1086	990	1192	812	1310	625	
	85	1238	1238	1362	1034	1498	843	1199	1199	1311	1009	1442	820	1156	1156	1255	982	1381	795	1110	1110	1196	954	1314	769	
	90	1300	1300	1373	1176	1501	987	1261	1261	1323	1151	1445	964	1217	1217	1269	1124	1384	939	1169	1169	1210	1095	1314	915	
31000	75	1276	1007	1407	791	1542	567	1226	981	1352	767	1482	545	1171	953	1292	741	1417	520	1114	923	1227	713	1345	494	
	80	1294	1178	1411	963	1543	738	1245	1152	1357	939	1484	715	1191	1124	1293	913	1419	691	1118	1118	1229	884	1348	664	
	85	1321	1321	1417	1131	1546	908	1279	1279	1363	1105	1487	885	1232	1232	1304	1078	1423	861	1181	1181	1241	1048	1352	834	
	90	1388	1388	1434	1299	1547	1080	1344	1344	1381	1274	1488	1056	1296	1296	1324	1246	1424	1029	1243	1243	1242	1242	1354	1000	
36000	75	1317	1082	1444	836	1577	580	1265	1055	1387	812	1515	557	1208	1026	1324	786	1447	533	1148	996	1256	758	1372	506	
	80	1318	1318	1449	1033	1579	776	1273	1273	1389	1007	1517	753	1224	1224	1327	979	1450	728	1171	1171	1260	948	1376	701	
	85	1388	1388	1460	1223	1583	971	1342	1342	1404	1197	1521	948	1292	1292	1343	1168	1450	928	1237	1237	1277	1138	1377	898	
	90	1458	1458	1457	1457	1586	1163	1410	1410	1410	1410	1524	1138	1358	1358	1358	1358	1458	1111	1301	1301	1300	1300	1386	1081	
41000	75	1351	1153	1473	879	1605	592	1297	1126	1414	854	1540	569	1238	1096	1349	828	1470	544	1176	1065	1274	803	1393	518	
	80	1369	1369	1478	1101	1607	812	1322	1322	1418	1070	1542	789	1270	1270	1355	1041	1473	764	1214	1214	1286	1010	1397	737	
	85	1442	1442	1495	1310	1608	1036	1394	1394	1437	1284	1544	1010	1340	1340	1375	1255	1475	983	1282	1282	1307	1224	1399	953	
	90	1514	1514	1513	1513	1617	1243	1463	1463	1463	1463	1553	1217	1408	1408	1408	1408	1408	1485	1189	1348	1348	1347	1347	1411	1159
46000	75	1379	1221	1496	920	1627	603	1324	1194	1431	899	1560	580	1264	1163	1365	870	1488	555	1200	1131	1293	839	1409	528	
	80	1412	1412	1503	1167	1629	847	1363	1363	1442	1130	1562	823	1309	1309	1377	1101	1491	798	1250	1250	1307	1070	1414	771	
	85	1487	1487	1524	1395	1631	1089	1436	1436	1466	1368	1564	1063	1380	1380	1402	1339	1493	1035	1319	1319	1333	1307	1417	1005	
	90	1560	1560	1559	1559	1645	1320	1507	1507	1506	1506	1577	1293	1449	1449	1448	1448	1507	1265	1385	1385	1384	1384	1431	1234	
51000	75	1403	1287	1511	961	1644	613	1321	1321	1449	935	1576	590	1266	1266	1381	905	1502	565	1207	1207	1308	874	1423	539	
	80	1448	1448	1523	1215	1648	880	1397	1397	1463	1188	1578	856	1341	1341	1397	1159	1506	832	1279	1279	1325	1127	1424	812	
	85	1524	1524	1549	1476	1650	1141	1471	1471	1490	1449	1581	1114	1413	1413	1426	1419	1510	1086	1349	1349	1356	1356	1432	1056	
	90	1599	1599	1598	1598	1668	1396	1542	1542	1542	1542	1598	1367	1482	1482	1482	1482	1526	1338	1416	1416	1415	1415	1449	1307	
54000	75	1389	1389	1521	982	1653	619	1338	1338	1458	955	1584	596	1282	1282	1390	926	1510	571	1222	1222	1316	894	1430	544	
	80	1468	1468	1535	1249	1657	900	1415	1415	1474	1222	1587	876	1358	1358	1407	1192	1511	859	1295	1295	1335	1160	1432	829	
	85	1544	1544	1564	1524	1661	1172	1490	1490	1503	1496	1591	1145	1431	1431	1439	1439	1518	1116	1365	1365	1368	1368	1440	1085	
	90	1620	1620	1619	1619	1681	1439	1561	1561	1561	1561	1609	1411	1500	1500	1499	1499	1519	1427	1431	1431	1431	1431	1430	1430	



Performance Data

Table 17. Gross cooling capacities – 120 tons eFlex™ variable speed – standard evaporator coil, 60Hz

CFM	Ent DB (°F)	Ambient Temperature (°F)																							
		85						95						105						115					
		Entering Wet Bulb (°F)			Entering Wet Bulb (°F)			Entering Wet Bulb (°F)			Entering Wet Bulb (°F)			Entering Wet Bulb (°F)			Entering Wet Bulb (°F)			Entering Wet Bulb (°F)					
		61	67	73	61	67	73	61	67	73	61	67	73	61	67	73	61	67	73						
21000	75	1170	843	1297	692	1432	537	1123	818	1245	667	1374	514	1072	790	1188	640	1312	487	1019	763	1129	613	1242	459
	80	1171	963	1300	812	1433	656	1125	936	1248	787	1376	632	1075	908	1192	760	1313	605	1024	879	1133	733	1245	578
	85	1183	1082	1303	932	1435	775	1137	1056	1252	907	1379	751	1088	1028	1193	880	1316	724	1032	1001	1135	852	1248	696
	90	1202	1197	1304	1051	1437	894	1158	1158	1254	1025	1381	869	1116	1116	1198	996	1319	842	1072	1072	1141	967	1251	813
26000	75	1236	933	1366	746	1497	554	1184	905	1310	720	1433	530	1127	875	1247	692	1366	502	1070	845	1182	664	1291	473
	80	1245	1077	1370	893	1498	699	1195	1049	1314	867	1436	674	1140	1019	1252	839	1367	647	1084	989	1187	810	1292	618
	85	1247	1247	1371	1039	1501	844	1204	1204	1315	1012	1439	819	1157	1157	1254	982	1370	791	1109	1109	1191	951	1295	761
	90	1309	1309	1382	1181	1503	988	1265	1265	1328	1154	1442	963	1217	1217	1267	1124	1371	937	1166	1166	1204	1092	1296	907
31000	75	1286	1012	1416	794	1540	566	1233	989	1355	768	1473	541	1172	953	1289	739	1400	514	1111	921	1219	710	1320	484
	80	1303	1184	1420	967	1541	737	1250	1155	1360	940	1474	712	1183	1136	1290	912	1401	684	1127	1093	1221	880	1321	654
	85	1330	1330	1425	1135	1544	907	1283	1283	1366	1107	1477	881	1231	1231	1301	1076	1404	853	1177	1177	1233	1044	1324	823
	90	1396	1396	1441	1303	1544	1079	1348	1348	1384	1275	1477	1051	1294	1294	1310	1257	1405	1021	1236	1236	1235	1235	1325	987
36000	75	1327	1087	1451	839	1572	578	1270	1058	1389	812	1498	551	1208	1026	1319	784	1422	524	1144	993	1246	753	1339	494
	80	1341	1297	1453	1036	1574	774	1278	1278	1391	1008	1500	747	1224	1224	1322	976	1423	718	1167	1167	1250	943	1340	688
	85	1396	1396	1466	1226	1578	970	1346	1346	1405	1197	1503	941	1290	1290	1337	1165	1424	917	1230	1230	1265	1132	1341	883
	90	1463	1463	1462	1462	1581	1161	1411	1411	1410	1410	1507	1131	1351	1351	1351	1351	1428	1098	1286	1286	1286	1286	1344	1063
41000	75	1360	1158	1478	881	1598	590	1302	1129	1413	854	1519	561	1237	1096	1342	825	1438	533	1171	1062	1262	797	1352	503
	80	1378	1378	1481	1098	1601	810	1326	1326	1418	1070	1522	782	1269	1269	1347	1038	1439	752	1208	1208	1272	1004	1352	721
	85	1449	1449	1498	1312	1602	1033	1395	1395	1435	1283	1524	1002	1335	1335	1365	1251	1440	969	1270	1270	1290	1178	1353	934
	90	1514	1514	1513	1513	1612	1241	1457	1457	1457	1457	1534	1209	1393	1393	1393	1393	1450	1175	1321	1321	1320	1320	1362	1139
46000	75	1388	1226	1499	921	1619	600	1328	1196	1429	898	1537	572	1251	1187	1356	866	1450	542	1187	1138	1278	832	1362	512
	80	1420	1420	1504	1158	1622	844	1366	1366	1439	1129	1540	816	1305	1305	1367	1104	1454	785	1241	1241	1289	1061	1363	754
	85	1490	1490	1523	1395	1623	1087	1434	1434	1459	1365	1542	1055	1370	1370	1387	1332	1456	1021	1300	1300	1309	1293	1366	985
	90	1557	1557	1556	1556	1636	1318	1493	1493	1492	1492	1555	1285	1423	1423	1422	1422	1469	1249	1346	1346	1345	1345	1377	1212
51000	75	1398	1325	1513	962	1635	611	1340	1325	1445	933	1551	582	1264	1264	1371	901	1462	552	1201	1201	1291	866	1371	521
	80	1455	1455	1523	1215	1638	878	1398	1398	1456	1186	1555	848	1335	1335	1383	1153	1465	822	1267	1267	1303	1117	1371	791
	85	1524	1524	1547	1475	1641	1138	1464	1464	1478	1444	1558	1106	1397	1397	1405	1400	1470	1071	1322	1322	1325	1325	1377	1034
	90	1595	1595	1594	1594	1656	1391	1527	1527	1526	1526	1573	1358	1451	1451	1451	1451	1484	1321	1369	1369	1368	1368	1382	1303
54000	75	1403	1397	1522	983	1643	616	1341	1341	1453	953	1558	588	1280	1280	1378	921	1469	557	1215	1215	1297	885	1375	526
	80	1472	1472	1533	1249	1647	897	1415	1415	1465	1219	1562	868	1350	1350	1391	1185	1470	843	1280	1280	1310	1149	1377	807
	85	1542	1542	1560	1523	1650	1168	1478	1478	1488	1484	1566	1135	1409	1409	1414	1414	1477	1100	1332	1332	1333	1333	1382	1062
	90	1615	1615	1614	1614	1668	1435	1544	1544	1543	1543	1580	1453	1466	1466	1465	1465	1488	1394	1380	1380	1380	1380	1402	1379

Table 18. Gross cooling capacities – 130 tons – standard evaporator coil, 60Hz

CFM	Ent DB (°F)	Ambient Temperature (°F)																									
		85						95						105						115							
		Entering Wet Bulb (°F)		73		61		Entering Wet Bulb (°F)		67		73		61		Entering Wet Bulb (°F)		67		73		61		Entering Wet Bulb (°F)		67	
CAP	SHC	CAP	SHC	CAP	SHC	CAP	SHC	CAP	SHC	CAP	SHC	CAP	SHC	CAP	SHC	CAP	SHC	CAP	SHC	CAP	SHC	CAP	SHC	CAP	SHC	CAP	SHC
23000	75	1340	965	1483	791	1631	612	1288	937	1427	765	1572	587	1232	907	1366	736	1507	560	1175	877	1302	706	1436	531		
	80	1342	1102	1486	928	1632	748	1291	1073	1431	902	1574	723	1236	1042	1370	873	1508	695	1179	1010	1307	843	1438	667		
	85	1353	1238	1489	1065	1635	883	1303	1209	1435	1039	1576	858	1249	1178	1374	1009	1512	831	1194	1146	1311	979	1442	801		
	90	1371	1371	1491	1201	1637	1018	1330	1330	1437	1173	1579	993	1284	1284	1378	1142	1515	965	1236	1236	1315	1111	1445	936		
26000	75	1385	1022	1529	825	1675	623	1331	994	1471	798	1614	598	1272	963	1407	769	1545	571	1211	933	1339	739	1471	542		
	80	1391	1174	1532	979	1676	775	1338	1151	1475	952	1615	750	1280	1120	1411	923	1547	723	1220	1089	1344	893	1474	693		
	85	1406	1328	1536	1133	1679	927	1355	1299	1479	1106	1618	902	1298	1267	1412	1075	1551	874	1241	1235	1346	1043	1478	845		
	90	1445	1445	1541	1283	1682	1079	1400	1400	1485	1254	1621	1053	1351	1351	1423	1223	1554	1025	1299	1299	1357	1191	1481	995		
30000	75	1434	1095	1577	868	1722	635	1374	1063	1516	841	1656	610	1315	1035	1449	811	1585	583	1251	1004	1378	780	1507	554		
	80	1445	1275	1581	1044	1724	810	1389	1236	1521	1016	1658	784	1328	1203	1454	987	1588	757	1265	1170	1383	956	1511	727		
	85	1456	1456	1584	1217	1727	984	1409	1409	1524	1189	1661	957	1357	1357	1459	1157	1591	930	1302	1302	1389	1124	1514	900		
	90	1526	1526	1595	1388	1730	1157	1479	1479	1537	1359	1664	1130	1426	1426	1473	1327	1594	1102	1369	1369	1404	1294	1515	1073		
35000	75	1481	1175	1623	917	1766	650	1422	1144	1559	890	1696	623	1357	1111	1490	860	1622	596	1290	1076	1415	829	1541	567		
	80	1499	1376	1627	1120	1769	851	1442	1346	1564	1093	1698	824	1379	1312	1492	1061	1625	797	1314	1278	1418	1027	1545	767		
	85	1536	1536	1633	1316	1773	1052	1486	1486	1572	1287	1701	1024	1430	1430	1504	1255	1628	997	1371	1371	1431	1220	1548	967		
	90	1609	1609	1650	1514	1774	1252	1558	1558	1590	1485	1704	1223	1501	1501	1524	1453	1631	1192	1440	1440	1453	1418	1552	1159		
40000	75	1521	1264	1657	963	1800	663	1460	1235	1592	936	1726	640	1393	1187	1520	907	1650	609	1324	1152	1443	875	1566	580		
	80	1545	1482	1660	1190	1804	891	1472	1472	1595	1161	1729	863	1414	1414	1525	1129	1654	836	1353	1353	1448	1094	1571	806		
	85	1601	1601	1673	1411	1808	1118	1548	1548	1610	1381	1732	1090	1489	1489	1540	1349	1654	1065	1426	1426	1465	1314	1572	1031		
	90	1676	1676	1697	1636	1813	1339	1621	1621	1620	1620	1737	1308	1561	1561	1560	1560	1661	1277	1495	1495	1494	1494	1580	1243		
45000	75	1553	1327	1685	1008	1828	675	1491	1296	1618	981	1750	648	1423	1261	1544	951	1672	621	1351	1225	1461	920	1587	591		
	80	1576	1576	1689	1256	1832	929	1521	1521	1623	1227	1754	901	1461	1461	1552	1208	1675	873	1396	1396	1473	1159	1591	844		
	85	1654	1654	1706	1503	1833	1184	1598	1598	1641	1473	1755	1153	1537	1537	1570	1440	1677	1121	1470	1470	1493	1405	1593	1088		
	90	1732	1732	1731	1731	1844	1424	1672	1672	1671	1671	1766	1392	1609	1609	1608	1608	1686	1359	1540	1540	1539	1539	1602	1325		
50000	75	1581	1399	1706	1052	1850	687	1518	1367	1636	1026	1770	659	1448	1332	1561	993	1691	632	1375	1295	1480	958	1604	603		
	80	1619	1619	1714	1320	1854	966	1562	1562	1646	1290	1773	938	1500	1500	1573	1257	1693	910	1432	1432	1493	1221	1607	880		
	85	1699	1699	1735	1593	1856	1241	1640	1640	1667	1562	1776	1209	1576	1576	1596	1529	1695	1177	1506	1506	1518	1493	1610	1143		
	90	1780	1780	1779	1779	1869	1506	1715	1715	1714	1714	1790	1473	1648	1648	1647	1647	1708	1440	1576	1576	1575	1575	1621	1405		
55000	75	1605	1469	1723	1094	1869	698	1541	1437	1653	1063	1787	670	1471	1401	1577	1030	1706	643	1384	1384	1495	994	1618	614		
	80	1655	1655	1735	1383	1873	1003	1597	1597	1665	1352	1790	974	1532	1532	1591	1319	1707	946	1462	1462	1511	1282	1619	919		
	85	1737	1737	1762	1681	1876	1297	1674	1674	1691	1648	1794	1265	1609	1609	1619	1615	1711	1232	1537	1537	1541	1541	1624	1197		
	90	1821	1821	1820	1820	1891	1586	1753	1753	1752	1752	1810	1553	1682	1682	1681	1681	1726	1519	1606	1606	1605	1605	1638	1483		
58000	75	1618	1510	1733	1116	1878	705	1553	1478	1662	1085	1796	677	1468	1468	1586	1052	1714	650	1399	1399	1503	1015	1625	620		
	80	1674	1674	1746	1420	1882	1024	1615	1615	1676	1388	1799	995	1550	1550	1601	1355	1715	971	1478	1478	1520	1318	1627	937		
	85	1758	1758	1776	1733	1887	1330	1693	1693	1704	1700	1804	1297	1626	1626	1632	1632	1720	1264	1553	1553	1554	1554	1631	1228		
	90	1842	1842	1842	1842	1903	1633	1773	1773	1772	1772	1821	1600	1700	1700	1699	1699	1737	1566	1622	1622	1621	1621	1647	1529		



Performance Data

Table 19. Gross cooling capacities – 130 tons eFlex™ variable speed – standard evaporator coil, 60Hz

CFM	Ent DB (°F)	Ambient Temperature (°F)																							
		85						95						105						115					
		Entering Wet Bulb (°F)		67		73		Entering Wet Bulb (°F)		61		67		73		Entering Wet Bulb (°F)		61		67		73			
23000	75	1341	965	1484	791	1629	610	1285	935	1424	762	1564	583	1226	904	1358	731	1492	553	1171	875	1294	702	1417	523
	80	1346	1104	1488	929	1630	746	1288	1071	1428	900	1565	719	1230	1038	1362	869	1493	688	1175	1008	1299	839	1419	658
	85	1354	1239	1491	1066	1632	882	1301	1207	1431	1037	1568	854	1243	1174	1366	1005	1497	824	1190	1144	1301	975	1422	793
	90	1377	1372	1493	1202	1635	1017	1329	1329	1434	1171	1571	989	1278	1278	1370	1138	1499	958	1231	1231	1307	1106	1425	927
26000	75	1387	1023	1530	825	1668	619	1328	992	1467	796	1601	592	1265	960	1397	764	1525	562	1206	930	1329	734	1447	531
	80	1392	1175	1534	980	1669	772	1334	1143	1471	950	1602	744	1273	1109	1402	918	1527	714	1215	1077	1334	887	1449	683
	85	1408	1330	1537	1133	1672	924	1352	1298	1473	1104	1605	896	1289	1263	1403	1071	1530	865	1236	1222	1336	1037	1451	833
	90	1447	1447	1543	1284	1675	1075	1398	1398	1481	1252	1607	1047	1345	1345	1414	1218	1533	1016	1292	1292	1347	1185	1454	984
30000	75	1434	1094	1577	867	1710	630	1373	1062	1511	838	1636	601	1305	1026	1438	805	1558	572	1243	993	1365	774	1475	541
	80	1446	1267	1581	1044	1711	805	1386	1234	1515	1014	1638	775	1321	1199	1443	981	1559	745	1259	1166	1370	949	1477	713
	85	1466	1445	1584	1217	1715	979	1407	1407	1519	1186	1639	948	1351	1351	1447	1151	1561	918	1295	1295	1375	1117	1479	885
	90	1529	1529	1595	1388	1719	1152	1476	1476	1532	1356	1642	1121	1418	1418	1461	1321	1563	1090	1359	1359	1389	1286	1479	1057
35000	75	1483	1176	1620	916	1751	643	1420	1150	1551	886	1668	613	1349	1106	1475	853	1585	582	1282	1072	1398	821	1499	551
	80	1501	1377	1624	1119	1754	845	1439	1344	1556	1089	1670	813	1371	1308	1477	1054	1586	782	1302	1271	1401	1019	1500	750
	85	1538	1538	1631	1315	1758	1046	1483	1483	1563	1283	1674	1014	1422	1422	1489	1247	1587	981	1360	1360	1412	1211	1501	950
	90	1609	1609	1646	1512	1760	1246	1552	1552	1580	1480	1676	1211	1489	1489	1501	1453	1589	1174	1422	1422	1429	1400	1501	1138
40000	75	1522	1253	1652	961	1782	656	1456	1219	1581	931	1694	624	1384	1182	1503	899	1605	592	1314	1146	1422	866	1517	561
	80	1539	1495	1654	1188	1786	884	1478	1449	1584	1156	1698	852	1406	1406	1507	1120	1606	818	1343	1343	1427	1084	1516	786
	85	1601	1601	1666	1407	1790	1111	1542	1542	1597	1375	1701	1080	1477	1477	1520	1339	1607	1045	1409	1409	1440	1302	1515	1008
	90	1670	1670	1680	1638	1794	1332	1608	1608	1607	1607	1707	1296	1540	1540	1539	1539	1615	1258	1466	1466	1465	1465	1521	1219
45000	75	1554	1328	1676	1005	1807	667	1486	1293	1604	975	1715	635	1412	1256	1522	943	1621	602	1340	1219	1438	909	1531	571
	80	1576	1576	1680	1252	1811	921	1517	1517	1608	1220	1720	889	1450	1450	1529	1184	1625	855	1383	1383	1447	1155	1528	821
	85	1650	1650	1696	1499	1812	1175	1588	1588	1622	1464	1721	1139	1519	1519	1544	1428	1626	1101	1446	1446	1462	1390	1530	1062
	90	1722	1722	1721	1721	1821	1415	1651	1651	1650	1650	1731	1377	1574	1574	1574	1574	1635	1338	1494	1494	1494	1494	1538	1298
50000	75	1581	1400	1695	1049	1826	678	1512	1365	1619	1019	1732	646	1437	1326	1538	983	1635	613	1362	1288	1453	945	1541	581
	80	1617	1617	1702	1315	1830	958	1555	1555	1627	1282	1736	925	1486	1486	1547	1245	1639	891	1414	1414	1463	1207	1540	859
	85	1690	1690	1723	1588	1832	1231	1623	1623	1644	1551	1739	1194	1551	1551	1563	1514	1642	1155	1473	1473	1480	1466	1543	1116
	90	1767	1767	1766	1766	1844	1496	1691	1691	1690	1690	1749	1457	1608	1608	1608	1608	1651	1417	1522	1522	1522	1522	1550	1376
55000	75	1603	1469	1710	1088	1842	689	1534	1434	1634	1055	1746	656	1451	1404	1551	1018	1647	623	1371	1371	1465	980	1550	591
	80	1650	1650	1721	1377	1845	993	1586	1586	1642	1341	1750	960	1515	1515	1561	1305	1650	928	1440	1440	1475	1266	1550	891
	85	1726	1726	1748	1675	1848	1286	1652	1652	1665	1637	1753	1248	1574	1574	1579	1579	1654	1208	1493	1493	1494	1494	1553	1168
	90	1803	1803	1803	1803	1864	1576	1723	1723	1722	1722	1767	1536	1636	1636	1635	1635	1665	1494	1544	1544	1543	1543	1562	1452
58000	75	1615	1510	1719	1110	1850	695	1538	1487	1641	1076	1754	663	1456	1456	1558	1039	1654	629	1385	1385	1471	1001	1555	597
	80	1667	1667	1732	1414	1853	1014	1602	1602	1650	1377	1756	983	1529	1529	1568	1340	1656	948	1452	1452	1481	1300	1555	908
	85	1746	1746	1762	1727	1858	1319	1669	1669	1678	1678	1760	1280	1587	1587	1590	1590	1660	1240	1502	1502	1502	1502	1558	1198
	90	1822	1822	1822	1822	1875	1622	1739	1739	1738	1738	1776	1582	1649	1649	1648	1648	1673	1540	1555	1555	1555	1555	1565	1501

Table 20. Gross cooling capacities – 150 tons – standard evaporator coil, 60Hz

CFM	Ent DB (°F)	Ambient Temperature (°F)																							
		85						95						105						115					
		Entering Wet Bulb (°F)						Entering Wet Bulb (°F)						Entering Wet Bulb (°F)						Entering Wet Bulb (°F)					
		61	67	73	79	85	91	61	67	73	79	85	91	61	67	73	79	85	91	61	67	73	79	85	91
23000	75	1468	1040	1623	860	1777	673	1411	1009	1565	831	1718	645	1351	977	1500	800	1651	617	1292	945	1434	769	1579	587
	80	1471	1184	1626	1002	1779	811	1415	1152	1568	973	1720	785	1355	1119	1504	942	1653	757	1296	1088	1439	911	1581	726
	85	1476	1328	1629	1143	1781	951	1421	1296	1572	1115	1723	925	1361	1257	1507	1083	1657	896	1303	1225	1442	1051	1585	866
	90	1491	1468	1632	1284	1783	1090	1440	1437	1575	1255	1725	1064	1389	1389	1511	1223	1659	1035	1341	1341	1443	1191	1588	1004
26000	75	1521	1102	1675	896	1827	681	1462	1070	1615	867	1764	656	1398	1037	1547	836	1695	628	1336	1005	1478	804	1619	598
	80	1523	1262	1678	1055	1829	839	1465	1229	1619	1027	1766	813	1402	1194	1551	995	1698	785	1340	1160	1482	963	1622	755
	85	1534	1420	1681	1214	1831	996	1477	1387	1622	1185	1769	970	1415	1352	1555	1153	1701	942	1356	1318	1486	1121	1626	911
	90	1566	1566	1685	1372	1834	1153	1518	1518	1625	1343	1771	1126	1465	1465	1559	1309	1703	1097	1413	1413	1490	1275	1628	1066
30000	75	1578	1179	1728	940	1876	699	1516	1147	1666	912	1811	668	1449	1113	1596	880	1739	644	1383	1080	1523	848	1660	610
	80	1584	1360	1731	1122	1882	876	1524	1333	1670	1094	1813	848	1457	1299	1601	1062	1742	820	1392	1255	1528	1029	1664	790
	85	1600	1542	1735	1303	1885	1055	1543	1510	1675	1275	1815	1027	1481	1476	1603	1243	1745	999	1422	1422	1532	1209	1667	968
	90	1656	1656	1740	1481	1887	1235	1607	1607	1681	1452	1818	1206	1551	1551	1613	1418	1747	1177	1493	1493	1541	1383	1670	1146
35000	75	1632	1270	1778	991	1929	710	1566	1235	1714	963	1855	682	1496	1198	1642	932	1781	655	1428	1170	1565	899	1699	625
	80	1643	1476	1781	1201	1932	919	1581	1443	1718	1173	1858	890	1513	1407	1647	1142	1784	862	1444	1370	1570	1109	1703	832
	85	1672	1672	1786	1409	1934	1126	1620	1620	1723	1380	1860	1097	1562	1562	1653	1346	1785	1069	1500	1500	1577	1310	1705	1038
	90	1746	1746	1797	1614	1937	1334	1695	1695	1735	1584	1863	1305	1636	1636	1667	1551	1788	1275	1573	1573	1593	1515	1707	1244
40000	75	1673	1350	1816	1040	1967	723	1609	1327	1750	1012	1889	695	1536	1280	1676	981	1813	668	1464	1243	1597	948	1730	643
	80	1691	1588	1820	1279	1970	960	1629	1555	1753	1251	1891	931	1561	1519	1680	1217	1815	903	1491	1482	1601	1181	1732	872
	85	1743	1743	1828	1510	1971	1195	1689	1689	1762	1479	1894	1166	1629	1629	1691	1446	1815	1137	1563	1563	1613	1410	1733	1106
	90	1820	1820	1847	1744	1975	1431	1764	1764	1780	1712	1898	1399	1703	1703	1712	1680	1820	1367	1636	1636	1635	1635	1737	1333
45000	75	1708	1430	1846	1088	1997	742	1643	1397	1778	1059	1917	708	1570	1360	1703	1029	1839	680	1495	1322	1622	996	1754	651
	80	1732	1697	1850	1351	1999	1000	1666	1666	1782	1321	1919	971	1603	1603	1709	1297	1838	942	1536	1536	1628	1251	1754	912
	85	1802	1802	1864	1609	2000	1263	1745	1745	1794	1577	1921	1234	1682	1682	1723	1544	1840	1206	1613	1613	1644	1507	1756	1172
	90	1883	1883	1889	1869	2006	1521	1820	1820	1820	1820	1928	1488	1756	1756	1756	1756	1846	1455	1686	1686	1685	1685	1760	1420
50000	75	1737	1508	1871	1134	2022	749	1671	1475	1800	1106	1940	720	1598	1438	1724	1076	1860	693	1521	1399	1642	1043	1773	663
	80	1768	1768	1878	1421	2022	1040	1712	1712	1806	1402	1941	1011	1647	1647	1732	1355	1858	982	1577	1577	1650	1318	1772	952
	85	1852	1852	1895	1707	2024	1331	1790	1790	1822	1673	1943	1299	1726	1726	1749	1640	1860	1266	1655	1655	1670	1603	1774	1231
	90	1935	1935	1934	1934	2032	1609	1869	1869	1868	1868	1952	1576	1800	1800	1799	1799	1868	1542	1726	1726	1725	1725	1781	1503
55000	75	1762	1584	1891	1181	2043	761	1696	1551	1818	1152	1959	732	1622	1514	1741	1118	1877	705	1545	1474	1657	1080	1790	676
	80	1809	1809	1901	1506	2042	1079	1750	1750	1826	1456	1959	1050	1684	1684	1752	1422	1874	1021	1612	1612	1669	1385	1787	991
	85	1896	1896	1922	1803	2044	1392	1829	1829	1847	1768	1962	1359	1762	1762	1773	1734	1877	1325	1689	1689	1694	1694	1789	1289
	90	1978	1978	1978	1978	2056	1697	1910	1910	1909	1909	1972	1663	1836	1836	1836	1836	1887	1628	1759	1759	1759	1759	1797	1592
58000	75	1775	1629	1901	1207	2053	768	1710	1596	1828	1175	1969	740	1636	1558	1751	1141	1887	712	1558	1518	1666	1103	1799	683
	80	1831	1831	1913	1529	2052	1102	1769	1769	1838	1495	1968	1073	1703	1703	1762	1461	1883	1044	1630	1630	1679	1424	1798	1016
	85	1918	1918	1937	1860	2055	1427	1850	1850	1862	1825	1972	1394	1781	1781	1787	1787	1886	1360	1707	1707	1707	1707	1777	1777
	90	2001	2001	2001	2001	2069	1749	1931	1931	1930	1930	1983	1714	1857	1857	1856	1856	1898	1680	1777	1777	1777	1777	1808	1635



Performance Data

Table 21. Gross cooling capacities – 150 tons eFlex™ variable speed – standard evaporator coil, 60Hz

CFM	Ent DB (°F)	Ambient Temperature (°F)																							
		85						95						105						115					
		Entering Wet Bulb (°F)						Entering Wet Bulb (°F)						Entering Wet Bulb (°F)						Entering Wet Bulb (°F)					
		61	67	73	79	85	91	61	67	73	79	85	91	61	67	73	79	85	91	61	67	73	79	85	91
23000	75	1479	1047	1638	867	1792	676	1418	1013	1573	835	1725	647	1358	981	1505	803	1652	616	1313	957	1451	777	1583	588
	80	1482	1190	1642	1010	1793	817	1422	1157	1577	978	1727	788	1362	1124	1510	945	1654	756	1317	1099	1454	918	1585	727
	85	1486	1331	1645	1152	1795	957	1427	1296	1581	1119	1730	928	1368	1262	1513	1086	1657	896	1323	1236	1457	1059	1587	867
	90	1502	1472	1648	1293	1797	1097	1448	1430	1584	1261	1732	1067	1395	1391	1517	1227	1659	1035	1356	1356	1460	1198	1590	1005
	75	1534	1109	1692	904	1837	685	1469	1074	1624	871	1767	656	1405	1041	1552	838	1691	626	1356	1015	1491	810	1618	596
26000	80	1538	1269	1695	1063	1839	843	1474	1234	1628	1031	1769	814	1409	1198	1556	997	1694	783	1360	1172	1495	969	1620	753
	85	1547	1428	1698	1223	1841	1001	1484	1392	1632	1190	1771	971	1422	1357	1561	1156	1696	940	1374	1330	1499	1127	1622	909
	90	1578	1571	1702	1381	1844	1158	1525	1525	1636	1348	1773	1127	1471	1471	1564	1312	1698	1095	1426	1426	1502	1281	1624	1064
	75	1592	1187	1745	947	1882	701	1524	1152	1675	916	1807	666	1455	1117	1600	882	1729	636	1402	1090	1533	852	1652	607
	80	1598	1368	1749	1130	1888	878	1531	1331	1679	1098	1809	846	1463	1295	1604	1064	1731	815	1410	1266	1537	1034	1654	785
30000	85	1615	1552	1752	1312	1891	1058	1551	1511	1683	1280	1811	1025	1488	1466	1608	1244	1732	994	1438	1429	1541	1213	1654	963
	90	1671	1671	1757	1491	1894	1238	1615	1615	1690	1457	1813	1204	1556	1556	1616	1421	1733	1172	1503	1503	1549	1387	1655	1141
	75	1647	1277	1793	998	1932	710	1576	1241	1722	966	1843	677	1502	1202	1643	932	1763	647	1444	1172	1571	902	1683	618
	80	1660	1486	1796	1208	1935	920	1591	1449	1725	1177	1847	886	1519	1410	1648	1143	1762	854	1460	1379	1575	1112	1682	824
	85	1692	1674	1801	1417	1938	1128	1629	1629	1730	1384	1850	1094	1566	1566	1653	1347	1761	1060	1510	1510	1581	1313	1680	1029
40000	90	1761	1761	1811	1621	1942	1336	1703	1703	1742	1588	1853	1302	1638	1638	1667	1551	1762	1265	1576	1576	1594	1516	1681	1233
	75	1690	1360	1827	1045	1967	723	1618	1323	1755	1014	1874	689	1542	1284	1675	980	1787	658	1479	1252	1599	949	1706	629
	80	1709	1598	1830	1283	1970	960	1640	1562	1758	1252	1878	926	1566	1523	1678	1217	1784	891	1503	1474	1603	1183	1701	861
	85	1759	1759	1839	1516	1972	1196	1698	1698	1766	1482	1881	1162	1631	1631	1688	1445	1786	1126	1568	1568	1611	1410	1699	1095
	90	1831	1831	1856	1750	1976	1430	1766	1766	1780	1711	1885	1394	1698	1698	1706	1662	1791	1355	1630	1630	1633	1614	1699	1318
45000	75	1725	1440	1854	1091	1994	735	1652	1403	1779	1060	1899	701	1574	1363	1698	1027	1806	669	1508	1329	1620	996	1724	640
	80	1749	1696	1859	1356	1996	999	1682	1649	1783	1321	1902	965	1606	1606	1703	1285	1805	930	1543	1543	1625	1249	1715	899
	85	1814	1814	1872	1614	1997	1263	1750	1750	1792	1577	1903	1228	1680	1680	1714	1541	1807	1191	1611	1611	1635	1504	1714	1156
	90	1890	1890	1900	1854	2003	1520	1816	1816	1821	1801	1909	1482	1740	1740	1740	1740	1812	1442	1667	1667	1666	1666	1718	1403
	75	1754	1518	1876	1137	2016	746	1681	1480	1798	1106	1919	713	1601	1440	1716	1071	1822	680	1532	1405	1636	1038	1738	651
50000	80	1783	1783	1884	1424	2016	1038	1719	1719	1803	1388	1920	1004	1648	1648	1722	1351	1821	969	1580	1580	1642	1315	1727	936
	85	1860	1860	1902	1711	2019	1327	1789	1789	1816	1672	1922	1291	1717	1717	1735	1634	1823	1252	1645	1645	1655	1597	1728	1213
	90	1940	1940	1939	1939	2028	1608	1860	1860	1860	1860	1927	1567	1777	1777	1776	1776	1829	1527	1694	1694	1693	1693	1733	1485
	75	1778	1593	1895	1181	2033	758	1705	1556	1814	1148	1935	724	1625	1516	1731	1113	1836	691	1553	1479	1651	1078	1751	662
	80	1821	1821	1906	1492	2034	1076	1754	1754	1819	1453	1934	1042	1681	1681	1737	1416	1834	1008	1610	1610	1656	1380	1742	975
55000	85	1902	1902	1928	1807	2037	1389	1823	1823	1840	1766	1937	1350	1745	1745	1752	1714	1837	1309	1669	1669	1672	1656	1739	1270
	90	1979	1979	1978	1978	2051	1696	1896	1896	1895	1895	1945	1653	1808	1808	1807	1807	1842	1611	1721	1721	1720	1720	1744	1571
	75	1791	1638	1905	1207	2043	764	1717	1601	1823	1173	1944	731	1637	1560	1739	1136	1844	698	1562	1516	1658	1100	1757	669
	80	1841	1841	1918	1532	2043	1099	1772	1772	1828	1492	1943	1066	1698	1698	1745	1455	1841	1029	1625	1625	1663	1418	1747	995
	85	1924	1924	1942	1863	2047	1425	1843	1843	1854	1810	1944	1384	1759	1759	1764	1746	1843	1344	1681	1681	1682	1682	1745	1304
90	2000	2000	2000	2000	2063	1748	1913	1913	1912	1912	1912	1912	1823	1823	1822	1822	1849	1661	1734	1734	1733	1733	1751	1612	

Table 22. Gross cooling capacities – 90 tons – high capacity evaporator coil, 60Hz

CFM	Ent DB (°F)	Ambient Temperature (°F)																										
		85						95						105						115								
		61			67			73			61			67			73			61			67			73		
		CAP	SHC	SHC	CAP	SHC	SHC	CAP	SHC	SHC	CAP	SHC	SHC	CAP	SHC	SHC	CAP	SHC	SHC	CAP	SHC	SHC	CAP	SHC	SHC			
16000	75	954	682	1052	559	1153	432	917	661	1012	540	1110	414	879	641	970	520	1065	395	846	624	930	501	1021	377			
	80	956	778	1055	655	1154	527	919	756	1015	635	1112	509	882	735	973	615	1067	490	849	716	933	596	1023	472			
	85	963	872	1057	750	1156	621	926	850	1018	731	1114	603	889	829	975	710	1070	584	855	809	935	691	1026	566			
	90	974	969	1059	845	1158	715	941	941	1020	825	1116	697	909	909	978	803	1072	678	879	879	938	782	1028	659			
20000	75	1012	758	1109	603	1206	445	971	737	1066	584	1160	428	927	712	1019	563	1113	409	889	692	976	544	1064	391			
	80	1017	872	1112	721	1207	562	977	850	1069	702	1163	545	935	827	1022	681	1116	526	895	806	979	662	1067	507			
	85	1028	990	1114	838	1209	679	989	968	1071	818	1166	661	949	946	1025	795	1119	642	912	912	983	774	1070	623			
	90	1064	1064	1120	952	1211	794	1030	1030	1078	931	1168	777	993	993	1032	908	1121	758	957	957	989	887	1072	738			
25000	75	1061	839	1156	653	1249	459	1017	816	1110	634	1202	442	971	792	1061	613	1152	424	929	770	1015	594	1100	405			
	80	1071	983	1158	799	1250	603	1029	960	1112	777	1205	586	984	936	1064	755	1156	568	942	914	1018	733	1103	548			
	85	1098	1098	1163	937	1251	746	1062	1062	1119	916	1207	729	1021	1021	1072	894	1157	711	983	983	1025	871	1105	691			
	90	1148	1148	1172	1078	1253	887	1111	1111	1129	1057	1209	868	1071	1071	1083	1035	1160	848	1031	1031	1037	1013	1108	826			
30000	75	1097	916	1187	701	1279	472	1052	893	1140	681	1231	455	1003	868	1087	661	1179	437	959	845	1039	639	1125	418			
	80	1113	1088	1190	866	1280	642	1067	1067	1144	845	1233	625	1024	1024	1095	822	1182	607	985	985	1046	800	1127	588			
	85	1158	1158	1198	1031	1280	811	1119	1119	1152	1010	1234	793	1078	1078	1105	988	1183	772	1035	1035	1055	965	1129	750			
	90	1208	1208	1212	1200	1284	972	1169	1169	1169	1169	1237	953	1127	1127	1127	1127	1186	932	1083	1083	1082	1082	1132	909			
33000	75	1114	961	1200	729	1294	479	1068	937	1152	707	1245	462	1019	912	1102	684	1192	444	974	889	1052	662	1137	426			
	80	1134	1134	1205	905	1293	665	1094	1094	1158	884	1246	649	1051	1051	1109	861	1194	631	1009	1009	1058	838	1138	611			
	85	1187	1187	1214	1087	1293	846	1147	1147	1169	1066	1246	827	1104	1104	1121	1043	1195	806	1060	1060	1070	1020	1140	783			
	90	1236	1236	1236	1236	1298	1022	1197	1197	1197	1197	1249	1002	1153	1153	1153	1153	1198	981	1107	1107	1106	1106	1143	959			
36000	75	1128	1004	1213	752	1306	487	1083	981	1164	730	1256	470	1033	955	1113	707	1203	452	988	932	1062	684	1147	433			
	80	1158	1158	1218	944	1304	688	1117	1117	1171	922	1256	672	1074	1074	1121	900	1204	655	1030	1030	1070	876	1148	632			
	85	1211	1211	1228	1141	1305	880	1171	1171	1184	1120	1257	860	1127	1127	1135	1098	1205	839	1080	1080	1084	1074	1149	816			
	90	1261	1261	1261	1261	1310	1072	1220	1220	1219	1219	1260	1051	1175	1175	1175	1175	1209	1030	1127	1127	1127	1127	1153	1007			
40000	75	1146	1061	1227	782	1320	496	1100	1038	1177	760	1269	479	1050	1012	1126	737	1215	461	1004	988	1074	713	1159	443			
	80	1186	1186	1232	994	1319	720	1144	1144	1185	973	1270	700	1099	1099	1135	950	1216	679	1053	1053	1082	926	1159	656			
	85	1238	1238	1245	1213	1318	925	1197	1197	1201	1192	1268	905	1152	1152	1153	1153	1216	883	1103	1103	1103	1103	1159	860			
	90	1289	1289	1289	1289	1325	1138	1245	1245	1245	1245	1245	1116	1199	1199	1199	1199	1220	1095	1149	1149	1149	1149	1164	1071			



Performance Data

Table 23. Gross cooling capacities – 90 tons eFlex™ variable speed – high capacity evaporator coil, 60Hz

CFM	Ent DB (°F)	Ambient Temperature (°F)																							
		85						95						105						115					
		Entering Wet Bulb (°F)			Entering Wet Bulb (°F)			Entering Wet Bulb (°F)			Entering Wet Bulb (°F)			Entering Wet Bulb (°F)			Entering Wet Bulb (°F)			Entering Wet Bulb (°F)					
		61	67	73	61	67	73	61	67	73	61	67	73	61	67	73	61	67	73						
16000	75	959	684	1063	564	1164	436	921	663	1016	541	1114	415	897	651	971	520	1061	393	914	738	944	507	1012	373
	80	962	780	1066	660	1165	531	924	759	1019	637	1116	510	899	745	974	615	1064	488	914	753	944	601	1014	467
	85	968	875	1068	756	1167	626	929	852	1022	732	1118	604	903	837	976	710	1066	582	915	844	945	695	1016	561
	90	981	962	1071	850	1169	720	946	936	1025	827	1121	698	918	914	979	803	1068	676	922	911	947	786	1018	654
20000	75	1020	761	1122	609	1211	447	973	736	1070	585	1160	427	935	716	1019	562	1102	404	924	758	977	544	1046	383
	80	1026	877	1125	727	1213	564	980	852	1074	704	1162	543	941	830	1022	680	1105	521	923	820	978	660	1048	499
	85	1036	995	1128	844	1214	680	993	963	1078	820	1163	659	954	935	1025	795	1107	637	932	917	981	773	1050	614
	90	1074	1074	1133	959	1214	796	1034	1034	1083	934	1165	775	993	993	1032	908	1108	752	960	960	960	885	1050	728
25000	75	1072	845	1167	658	1245	457	1021	818	1114	635	1192	438	973	793	1058	611	1132	416	944	778	1007	590	1072	394
	80	1084	990	1170	803	1246	601	1034	963	1118	779	1192	580	985	936	1061	753	1133	558	950	913	1009	729	1071	536
	85	1110	1110	1174	943	1248	745	1066	1066	1123	918	1191	723	1021	1021	1068	892	1132	700	981	981	1015	867	1070	676
	90	1158	1158	1182	1084	1250	885	1115	1115	1133	1059	1192	861	1068	1068	1078	1029	1132	836	1021	1021	1027	994	1070	809
30000	75	1110	923	1195	704	1270	468	1057	896	1141	681	1211	447	1004	868	1082	656	1151	426	964	848	1028	632	1088	404
	80	1126	1084	1198	870	1271	639	1077	1050	1146	846	1210	617	1026	1015	1087	819	1147	594	982	982	1031	793	1084	573
	85	1169	1169	1204	1035	1273	807	1123	1123	1153	1011	1210	783	1073	1073	1096	984	1147	757	1024	1024	1038	957	1081	729
	90	1211	1211	1218	1179	1278	970	1165	1165	1168	1146	1213	943	1113	1113	1113	1113	1145	915	1058	1058	1058	1058	1078	887
33000	75	1127	968	1208	729	1281	474	1074	940	1154	706	1221	454	1019	912	1093	680	1159	432	975	889	1037	655	1095	411
	80	1150	1128	1211	908	1283	661	1099	1099	1158	884	1219	639	1049	1049	1099	857	1156	616	1003	1003	1041	830	1089	591
	85	1194	1194	1217	1089	1284	842	1148	1148	1165	1064	1219	816	1096	1096	1108	1037	1153	789	1043	1043	1049	1010	1086	761
	90	1236	1236	1235	1235	1293	1021	1183	1183	1183	1183	1224	992	1128	1128	1128	1128	1154	963	1068	1068	1068	1068	1082	933
36000	75	1142	1012	1219	753	1290	481	1088	984	1163	729	1229	460	1033	955	1102	702	1165	438	985	931	1045	676	1102	417
	80	1169	1169	1221	946	1293	684	1121	1121	1168	921	1228	660	1070	1070	1108	894	1162	636	1020	1020	1049	866	1097	611
	85	1214	1214	1227	1141	1296	877	1167	1167	1176	1117	1228	849	1113	1113	1118	1080	1157	820	1057	1057	1059	1038	1089	791
	90	1258	1258	1258	1258	1305	1071	1202	1202	1202	1202	1235	1041	1141	1141	1141	1141	1161	1011	1077	1077	1076	1076	1087	979
40000	75	1159	1068	1230	783	1301	489	1102	1043	1174	758	1239	469	1048	1005	1113	730	1173	447	999	970	1054	703	1109	426
	80	1194	1194	1231	994	1304	711	1145	1145	1178	970	1236	687	1091	1091	1118	942	1170	660	1038	1038	1057	914	1101	632
	85	1236	1236	1244	1197	1309	921	1184	1184	1187	1157	1238	892	1128	1128	1130	1120	1165	862	1069	1069	1069	1069	1092	832
	90	1286	1286	1286	1286	1319	1136	1224	1224	1224	1224	1247	1106	1158	1158	1157	1157	1171	1074	1088	1088	1088	1088	1092	1040

Table 24. Gross cooling capacities – 105 tons – high capacity evaporator coil, 60Hz

CFM	Ent DB (°F)	Ambient Temperature (°F)																										
		85						95						105						115								
		61			67			73			61			67			73			61			67			73		
		CAP	SHC	SHC	CAP	SHC	SHC	CAP	SHC	SHC	CAP	SHC	SHC	CAP	SHC	SHC	CAP	SHC	SHC	CAP	SHC	SHC	CAP	SHC	SHC			
19000	75	1101	794	1211	647	1322	495	1057	770	1163	624	1274	475	1010	746	1115	602	1222	456	971	725	1069	580	1168	432			
	80	1104	907	1214	760	1324	607	1060	882	1166	737	1277	587	1014	856	1119	715	1225	566	974	834	1072	693	1171	544			
	85	1112	1019	1216	874	1327	719	1068	994	1169	851	1279	699	1022	968	1122	828	1227	677	983	945	1075	806	1173	655			
	90	1129	1129	1219	985	1328	831	1092	1092	1172	961	1281	811	1054	1054	1126	937	1230	788	1019	1019	1079	913	1175	766			
23000	75	1155	869	1263	690	1373	508	1107	844	1214	668	1322	488	1056	816	1163	645	1266	467	1014	793	1112	623	1208	445			
	80	1161	1000	1266	826	1375	642	1114	974	1218	804	1325	622	1066	948	1167	781	1269	601	1022	924	1115	758	1211	578			
	85	1173	1136	1269	960	1377	776	1128	1111	1221	937	1327	756	1083	1083	1170	912	1272	734	1044	1044	1119	887	1213	711			
	90	1216	1216	1276	1091	1378	910	1176	1176	1228	1067	1329	890	1136	1136	1178	1042	1274	867	1094	1094	1126	1017	1214	844			
28000	75	1203	949	1309	740	1417	522	1152	923	1259	718	1363	502	1102	896	1204	695	1305	481	1054	871	1149	672	1243	459			
	80	1214	1110	1313	904	1418	684	1164	1084	1263	882	1366	664	1116	1058	1208	859	1308	642	1067	1032	1152	828	1246	619			
	85	1244	1244	1318	1059	1419	845	1202	1202	1269	1035	1367	824	1158	1158	1215	1010	1309	803	1113	1113	1159	983	1246	780			
	90	1299	1299	1327	1217	1421	1003	1258	1258	1279	1194	1369	980	1212	1212	1226	1168	1311	956	1164	1164	1171	1142	1249	930			
33000	75	1239	1026	1343	788	1448	535	1188	1000	1290	766	1393	516	1136	973	1231	744	1332	494	1085	947	1174	718	1269	472			
	80	1255	1216	1346	971	1448	723	1207	1191	1294	947	1394	703	1157	1157	1238	921	1334	682	1110	1110	1180	894	1270	659			
	85	1305	1305	1354	1154	1449	911	1262	1262	1303	1130	1395	889	1214	1214	1247	1104	1335	864	1164	1164	1188	1077	1271	837			
	90	1362	1362	1368	1341	1453	1088	1317	1317	1317	1317	1396	1065	1268	1268	1268	1268	1337	1040	1216	1216	1215	1215	1273	1013			
38000	75	1268	1101	1366	833	1473	548	1216	1074	1312	808	1416	528	1162	1047	1254	782	1354	507	1109	1019	1194	755	1289	485			
	80	1293	1293	1372	1037	1471	762	1249	1249	1319	1013	1415	743	1200	1200	1261	986	1354	721	1149	1149	1200	958	1289	699			
	85	1354	1354	1381	1247	1473	969	1308	1308	1329	1222	1415	945	1257	1257	1272	1196	1354	920	1204	1204	1212	1168	1288	893			
	90	1410	1410	1410	1410	1476	1172	1362	1362	1362	1362	1417	1148	1310	1310	1310	1310	1356	1123	1254	1254	1254	1254	1290	1095			
43000	75	1291	1173	1386	871	1492	560	1239	1147	1331	846	1434	540	1184	1119	1272	819	1371	519	1129	1090	1211	791	1305	497			
	80	1332	1332	1392	1101	1491	803	1285	1285	1338	1076	1434	780	1234	1234	1279	1049	1371	755	1180	1180	1217	1021	1304	728			
	85	1391	1391	1404	1337	1491	1025	1344	1344	1352	1313	1431	1001	1291	1291	1295	1286	1369	975	1235	1235	1235	1235	1302	947			
	90	1449	1449	1449	1449	1496	1255	1397	1397	1397	1397	1434	1230	1343	1343	1342	1342	1371	1204	1284	1284	1284	1284	1305	1176			
45000	75	1299	1202	1393	886	1499	565	1247	1175	1338	861	1440	545	1192	1147	1278	834	1377	524	1137	1118	1216	805	1311	502			
	80	1345	1345	1398	1126	1497	815	1298	1298	1344	1101	1439	792	1246	1246	1285	1074	1376	767	1191	1191	1223	1045	1309	739			
	85	1404	1404	1413	1373	1497	1047	1356	1356	1360	1349	1436	1022	1303	1303	1303	1303	1373	997	1246	1246	1245	1245	1306	969			
	90	1463	1463	1462	1462	1503	1289	1409	1409	1409	1409	1440	1263	1354	1354	1353	1353	1376	1236	1294	1294	1294	1294	1310	1208			



Performance Data

Table 25. Gross cooling capacities – 105 tons eFlex™ variable speed – high capacity evaporator coil, 60Hz

CFM	Ent DB (°F)	Ambient Temperature (°F)																							
		85						95						105						115					
		Entering Wet Bulb (°F)						Entering Wet Bulb (°F)						Entering Wet Bulb (°F)						Entering Wet Bulb (°F)					
		61	67	73	79	85	91	61	67	73	79	85	91	61	67	73	79	85	91	61	67	73	79	85	91
19000	75	1101	793	1212	646	1318	491	1052	767	1157	620	1263	469	1014	747	1106	596	1203	445	1006	742	1069	579	1146	422
	80	1104	906	1215	760	1319	604	1056	879	1161	734	1265	581	1017	857	1110	709	1206	557	1006	851	1070	691	1148	533
	85	1112	1019	1218	874	1321	716	1064	991	1164	847	1267	693	1023	968	1113	823	1208	668	1006	958	1071	803	1150	644
	90	1131	1129	1221	986	1323	828	1089	1089	1168	958	1269	804	1050	1050	1117	932	1210	779	1027	1027	1074	910	1151	754
23000	75	1155	868	1263	689	1360	502	1101	839	1206	663	1303	479	1053	813	1150	638	1239	455	1031	801	1102	617	1177	432
	80	1163	1001	1266	825	1361	636	1109	971	1210	799	1304	613	1061	945	1154	774	1241	588	1033	930	1104	752	1177	564
	85	1176	1137	1269	960	1362	769	1124	1107	1214	932	1305	746	1079	1071	1158	905	1242	721	1046	1046	1106	880	1177	696
	90	1219	1219	1276	1090	1362	902	1172	1172	1222	1063	1305	879	1127	1127	1165	1035	1243	854	1086	1086	1112	1009	1178	827
28000	75	1204	949	1306	737	1393	512	1146	919	1248	713	1334	490	1093	891	1187	687	1268	467	1058	872	1131	663	1202	443
	80	1216	1111	1308	901	1395	674	1160	1081	1251	874	1332	650	1106	1053	1190	845	1266	626	1065	1031	1133	819	1199	601
	85	1245	1245	1314	1056	1398	836	1197	1197	1258	1029	1331	810	1148	1148	1197	1001	1265	786	1102	1102	1138	973	1199	759
	90	1297	1297	1322	1214	1400	993	1250	1250	1267	1188	1332	964	1197	1197	1206	1158	1264	935	1144	1144	1147	1122	1195	906
33000	75	1240	1026	1335	784	1418	524	1181	996	1276	759	1355	501	1124	967	1211	732	1288	477	1080	944	1151	706	1220	454
	80	1256	1217	1338	967	1421	712	1200	1183	1279	940	1351	687	1146	1146	1216	910	1282	662	1099	1099	1154	882	1213	638
	85	1303	1303	1343	1149	1422	899	1253	1253	1286	1122	1352	870	1198	1198	1223	1092	1280	840	1143	1143	1159	1062	1209	811
	90	1350	1350	1353	1332	1427	1077	1298	1298	1298	1298	1354	1047	1239	1239	1239	1239	1278	1015	1178	1178	1178	1178	1204	984
38000	75	1267	1101	1355	827	1438	535	1208	1070	1294	800	1371	512	1149	1040	1229	770	1303	488	1098	1014	1167	742	1234	465
	80	1292	1292	1358	1030	1440	750	1240	1240	1299	1003	1367	725	1185	1185	1234	973	1296	699	1131	1131	1169	943	1228	672
	85	1344	1344	1363	1238	1442	956	1291	1291	1305	1211	1367	925	1232	1232	1241	1181	1290	893	1171	1171	1175	1149	1215	862
	90	1393	1393	1392	1392	1451	1161	1331	1331	1330	1330	1372	1129	1265	1265	1264	1264	1292	1096	1196	1196	1196	1196	1210	1061
43000	75	1289	1172	1371	863	1454	546	1230	1142	1310	836	1384	523	1169	1111	1243	805	1315	500	1115	1082	1179	776	1245	477
	80	1326	1326	1372	1092	1454	788	1272	1272	1312	1064	1380	758	1214	1214	1246	1034	1306	728	1155	1155	1180	1003	1235	698
	85	1375	1375	1385	1329	1459	1012	1316	1316	1319	1298	1380	979	1254	1254	1254	1247	1299	946	1189	1189	1188	1188	1220	913
	90	1429	1429	1428	1428	1469	1244	1360	1360	1359	1359	1387	1210	1287	1287	1287	1287	1302	1175	1211	1211	1211	1210	1218	1139
45000	75	1296	1201	1376	878	1459	551	1238	1170	1315	850	1388	527	1176	1139	1248	819	1319	504	1121	1101	1183	789	1249	482
	80	1337	1337	1377	1116	1459	800	1283	1283	1317	1089	1384	769	1223	1223	1250	1058	1310	738	1163	1163	1183	1027	1238	708
	85	1387	1387	1393	1364	1465	1034	1325	1325	1326	1322	1384	1001	1260	1260	1260	1260	1303	967	1194	1194	1193	1193	1221	933
	90	1442	1442	1441	1441	1475	1277	1370	1370	1370	1370	1392	1242	1295	1295	1295	1295	1306	1206	1216	1216	1216	1216	1221	1169

Table 26. Gross cooling capacities – 120 tons – high capacity evaporator coil, 60Hz

CFM	Ent DB (°F)	Ambient Temperature (°F)																										
		85						95						105						115								
		61			67			73			61			67			73			61			67			73		
		CAP	SHC	SHC	CAP	SHC	SHC	CAP	SHC	SHC	CAP	SHC	SHC	CAP	SHC	SHC	CAP	SHC	SHC	CAP	SHC	SHC	CAP	SHC	SHC			
21000	75	1230	881	1363	724	1497	560	1564	578	1252	950	1383	757	1510	557	1195	921	1323	730	1450	533	1138	893	1260	702	1382	507	
	80	1233	1006	1366	849	1498	684	1500	806	1258	1105	1387	909	1513	707	1202	1068	1328	882	1454	683	1145	1038	1265	854	1387	658	
	85	1237	1132	1369	973	1500	806	1502	929	1274	1252	1391	1061	1515	856	1221	1221	1330	1032	1457	833	1173	1173	1268	1002	1391	807	
	90	1254	1252	1371	1096	1502	929	1502	929	1215	1215	1323	1072	1453	907	1173	1173	1265	1044	1397	883	1129	1129	1209	1015	1335	857	
26000	75	1304	976	1436	780	1564	578	1564	578	1252	950	1383	757	1510	557	1195	921	1323	730	1450	533	1138	893	1260	702	1382	507	
	80	1308	1126	1439	933	1567	729	1567	729	1258	1105	1387	909	1513	707	1202	1068	1328	882	1454	683	1145	1038	1265	854	1387	658	
	85	1322	1279	1442	1084	1570	879	1570	879	1274	1252	1391	1061	1515	856	1221	1221	1330	1032	1457	833	1173	1173	1268	1002	1391	807	
	90	1372	1372	1446	1232	1572	1028	1572	1028	1331	1331	1396	1207	1516	1005	1284	1284	1339	1179	1459	982	1277	1277	1329	1149	1393	956	
31000	75	1355	1062	1486	831	1613	593	1613	593	1302	1034	1432	808	1554	571	1243	1010	1370	781	1492	548	1181	971	1304	753	1421	522	
	80	1367	1239	1489	1011	1616	771	1616	771	1315	1212	1436	987	1556	748	1257	1181	1375	961	1496	725	1197	1150	1309	933	1427	699	
	85	1397	1397	1493	1186	1619	948	1619	948	1353	1353	1440	1161	1557	924	1304	1304	1380	1133	1498	901	1251	1251	1315	1102	1430	876	
	90	1462	1462	1501	1360	1621	1125	1621	1125	1419	1419	1450	1335	1560	1101	1369	1369	1392	1308	1499	1077	1315	1315	1329	1277	1432	1049	
36000	75	1397	1142	1523	879	1649	607	1649	607	1342	1114	1467	856	1588	584	1280	1082	1404	830	1523	561	1217	1050	1335	801	1450	540	
	80	1413	1348	1525	1086	1652	811	1652	811	1362	1321	1471	1063	1588	787	1303	1290	1407	1031	1526	765	1244	1244	1339	1000	1456	739	
	85	1466	1466	1531	1283	1653	1015	1653	1015	1421	1421	1478	1258	1590	991	1369	1369	1418	1230	1526	968	1312	1312	1351	1199	1457	942	
	90	1532	1532	1547	1486	1656	1215	1656	1215	1485	1485	1493	1460	1593	1189	1434	1434	1434	1434	1529	1163	1377	1377	1377	1377	1461	1135	
41000	75	1430	1219	1550	925	1678	619	1678	619	1375	1191	1493	902	1613	597	1312	1159	1427	877	1547	574	1246	1126	1358	848	1473	549	
	80	1451	1451	1553	1152	1679	850	1679	850	1404	1404	1497	1126	1613	827	1350	1350	1435	1098	1549	804	1291	1291	1365	1066	1477	779	
	85	1520	1520	1564	1378	1680	1082	1680	1082	1473	1473	1507	1352	1615	1055	1420	1420	1447	1324	1549	1029	1361	1361	1380	1293	1479	1000	
	90	1590	1590	1589	1589	1686	1302	1686	1302	1536	1536	1536	1536	1620	1275	1484	1484	1484	1484	1552	1247	1425	1425	1425	1425	1482	1219	
46000	75	1457	1294	1571	972	1700	632	1700	632	1402	1266	1513	946	1635	609	1338	1234	1446	916	1567	586	1272	1200	1374	883	1491	561	
	80	1494	1494	1578	1218	1701	889	1578	1218	1446	1446	1519	1192	1634	865	1391	1391	1457	1164	1566	842	1330	1330	1386	1132	1494	819	
	85	1566	1566	1592	1472	1703	1141	1592	1472	1514	1514	1532	1444	1635	1114	1461	1461	1473	1417	1567	1086	1400	1400	1406	1386	1496	1057	
	90	1637	1637	1636	1636	1710	1387	1636	1636	1581	1581	1581	1581	1641	1359	1523	1523	1523	1523	1572	1331	1463	1463	1462	1462	1500	1302	
51000	75	1480	1367	1589	1010	1719	644	1589	1010	1425	1339	1531	984	1652	622	1362	1307	1464	954	1583	599	1294	1272	1391	921	1507	573	
	80	1531	1531	1598	1284	1718	927	1598	1284	1481	1481	1537	1256	1651	905	1425	1425	1474	1228	1584	880	1363	1363	1404	1196	1509	850	
	85	1605	1605	1617	1565	1721	1198	1617	1565	1549	1549	1556	1536	1652	1171	1494	1494	1496	1496	1581	1142	1432	1432	1431	1431	1509	1113	
	90	1677	1677	1677	1677	1731	1472	1677	1677	1618	1618	1617	1617	1659	1443	1556	1556	1556	1556	1589	1414	1493	1493	1492	1492	1515	1384	
54000	75	1493	1411	1599	1032	1729	651	1599	1032	1437	1383	1540	1006	1662	629	1374	1350	1473	976	1592	606	1306	1304	1399	943	1514	581	
	80	1550	1550	1609	1322	1729	953	1609	1322	1499	1499	1547	1294	1660	925	1443	1443	1484	1266	1592	898	1379	1379	1413	1234	1517	867	
	85	1625	1625	1631	1619	1731	1233	1631	1619	1568	1568	1570	1570	1661	1205	1511	1511	1510	1510	1588	1175	1448	1448	1447	1447	1516	1146	
	90	1698	1698	1698	1698	1742	1522	1698	1698	1636	1636	1636	1636	1669	1492	1574	1574	1574	1574	1598	1464	1508	1508	1507	1507	1523	1432	

Table 27. Gross cooling capacities – 120 tons eFlex™ variable speed – high capacity evaporator coil, 60Hz

CFM	Ent DB (°F)	Ambient Temperature (°F)																							
		85						95						105						115					
		61		67		73		61		67		73		61		67		73		61		67		73	
		CAP	SHC	CAP	SHC	CAP	SHC	CAP	SHC	CAP	SHC	CAP	SHC	CAP	SHC	CAP	SHC	CAP	SHC	CAP	SHC	CAP	SHC	CAP	SHC
21000	75	1240	886	1378	730	1515	567	1188	858	1321	703	1458	543	1133	828	1260	674	1392	515	1083	802	1203	648	1326	489
	80	1244	1012	1381	855	1517	690	1190	983	1325	828	1460	666	1136	953	1264	799	1395	639	1085	924	1208	772	1329	611
	85	1248	1134	1384	980	1519	813	1197	1105	1328	952	1463	789	1143	1074	1268	923	1398	762	1095	1047	1211	896	1333	734
	90	1265	1258	1387	1104	1521	936	1220	1220	1332	1076	1465	912	1176	1176	1270	1046	1401	884	1134	1134	1214	1017	1336	856
26000	75	1317	983	1454	788	1579	582	1259	953	1394	760	1519	558	1197	921	1327	730	1450	532	1142	893	1264	703	1378	505
	80	1322	1133	1458	941	1582	733	1265	1102	1398	913	1521	709	1205	1070	1332	883	1454	683	1151	1041	1268	855	1383	655
	85	1336	1287	1461	1093	1584	884	1282	1256	1403	1066	1523	859	1226	1216	1336	1034	1457	832	1177	1177	1271	1003	1386	804
	90	1386	1386	1466	1241	1586	1034	1339	1339	1408	1213	1524	1008	1288	1288	1343	1181	1459	981	1238	1238	1280	1150	1388	953
31000	75	1373	1073	1505	839	1624	596	1310	1038	1443	812	1558	571	1245	1004	1374	782	1488	545	1186	974	1305	753	1413	518
	80	1383	1248	1509	1019	1629	774	1324	1217	1448	992	1559	748	1260	1183	1379	962	1490	722	1202	1152	1309	931	1417	694
	85	1413	1413	1512	1195	1632	952	1363	1363	1452	1167	1560	924	1307	1307	1385	1135	1491	898	1254	1254	1316	1102	1417	870
	90	1480	1480	1521	1370	1635	1130	1430	1430	1463	1342	1562	1102	1374	1374	1397	1310	1492	1074	1317	1317	1330	1278	1419	1043
36000	75	1414	1151	1541	886	1659	609	1352	1119	1478	860	1585	582	1284	1084	1407	830	1514	557	1221	1052	1335	801	1438	530
	80	1432	1358	1543	1093	1663	814	1372	1327	1481	1064	1587	786	1307	1287	1411	1032	1514	760	1247	1247	1339	999	1439	733
	85	1484	1484	1549	1291	1665	1019	1432	1432	1489	1263	1590	991	1373	1373	1421	1231	1513	963	1314	1314	1350	1198	1439	935
	90	1547	1547	1563	1494	1668	1220	1495	1495	1504	1465	1593	1189	1437	1437	1440	1424	1514	1156	1374	1374	1374	1374	1438	1125
41000	75	1449	1229	1566	931	1685	621	1385	1196	1503	906	1608	594	1315	1161	1428	876	1535	569	1250	1128	1353	844	1457	542
	80	1473	1460	1570	1159	1689	853	1415	1415	1507	1131	1610	825	1354	1354	1437	1099	1531	797	1294	1294	1363	1065	1455	770
	85	1537	1537	1580	1385	1690	1085	1484	1484	1516	1356	1612	1054	1423	1423	1449	1325	1530	1021	1359	1359	1376	1291	1453	990
	90	1603	1603	1603	1603	1695	1306	1541	1541	1541	1541	1617	1274	1480	1480	1479	1479	1535	1240	1413	1413	1413	1413	1450	1205
46000	75	1477	1304	1587	977	1706	633	1413	1272	1521	949	1626	605	1342	1236	1447	916	1551	580	1275	1202	1371	882	1473	554
	80	1513	1513	1592	1225	1708	891	1458	1458	1527	1195	1628	863	1395	1395	1457	1164	1544	834	1331	1331	1382	1130	1469	807
	85	1580	1580	1607	1479	1710	1143	1522	1522	1538	1447	1630	1111	1460	1460	1470	1416	1546	1077	1393	1393	1398	1378	1463	1043
	90	1649	1649	1649	1649	1719	1391	1583	1583	1582	1582	1635	1357	1511	1511	1511	1511	1511	1511	1511	1511	1511	1511	1511	1511
51000	75	1500	1378	1603	1016	1723	644	1437	1346	1537	986	1641	617	1365	1309	1463	953	1564	592	1295	1268	1386	918	1485	566
	80	1547	1547	1611	1290	1724	929	1492	1492	1542	1259	1643	901	1428	1428	1472	1227	1560	870	1361	1361	1397	1193	1482	838
	85	1618	1618	1631	1572	1727	1201	1552	1552	1558	1538	1644	1167	1488	1488	1489	1487	1558	1133	1418	1418	1418	1418	1471	1097
	90	1687	1687	1686	1686	1739	1476	1615	1615	1614	1614	1651	1440	1540	1540	1540	1540	1540	1540	1540	1540	1540	1540	1540	1540
54000	75	1512	1421	1612	1038	1732	651	1449	1389	1546	1009	1648	624	1376	1349	1471	975	1572	598	1306	1306	1394	940	1492	573
	80	1566	1566	1622	1328	1732	952	1508	1508	1550	1296	1650	921	1444	1444	1480	1264	1565	887	1376	1376	1404	1230	1487	855
	85	1638	1638	1645	1626	1736	1235	1570	1570	1572	1572	1650	1200	1500	1500	1500	1500	1500	1500	1500	1500	1500	1500	1500	1500
	90	1707	1707	1707	1707	1750	1526	1632	1632	1631	1631	1660	1489	1554	1554	1553	1553	1553	1553	1553	1553	1553	1553	1553	1553

Table 28. Gross cooling capacities – 130 tons – high capacity evaporator coil, 60Hz

CFM	Ent DB (°F)	Ambient Temperature (°F)																							
		85						95						105						115					
		Entering Wet Bulb (°F)			Entering Wet Bulb (°F)			Entering Wet Bulb (°F)			Entering Wet Bulb (°F)			Entering Wet Bulb (°F)			Entering Wet Bulb (°F)			Entering Wet Bulb (°F)					
		61	67	73	61	67	73	61	67	73	61	67	73	61	67	73	61	67	73						
23000	75	1400	1002	1697	636	1346	973	1493	797	1640	612	1287	941	1429	767	1575	585	1229	911	1365	737	1504	557		
	80	1404	1145	1698	776	1347	1114	1497	937	1642	752	1288	1081	1434	907	1577	724	1232	1049	1370	877	1507	695		
	85	1410	1288	1556	1105	1356	1252	1500	1078	1644	890	1299	1220	1438	1047	1581	863	1243	1188	1374	1017	1511	834		
	90	1429	1428	1559	1245	1383	1383	1504	1218	1647	1028	1335	1335	1439	1186	1583	1001	1288	1288	1376	1154	1514	972		
26000	75	1449	1062	1598	859	1392	1032	1539	832	1682	623	1330	1000	1473	802	1615	596	1269	969	1405	771	1541	567		
	80	1453	1220	1601	1017	1396	1189	1543	990	1684	779	1335	1155	1478	960	1618	752	1275	1129	1410	929	1545	723		
	85	1464	1377	1604	1175	1410	1346	1547	1147	1687	935	1350	1313	1482	1117	1621	908	1293	1281	1415	1083	1549	879		
	90	1505	1505	1607	1331	1459	1459	1550	1302	1689	1090	1408	1408	1486	1270	1624	1063	1356	1356	1420	1237	1552	1033		
30000	75	1502	1138	1647	902	1442	1108	1587	875	1725	635	1374	1073	1518	845	1656	609	1312	1044	1447	814	1580	580		
	80	1509	1323	1650	1083	1451	1285	1591	1056	1727	814	1387	1250	1523	1026	1660	787	1323	1216	1452	995	1584	758		
	85	1528	1499	1654	1263	1474	1469	1593	1236	1729	991	1417	1417	1527	1204	1662	965	1362	1362	1456	1170	1587	936		
	90	1590	1590	1660	1438	1542	1542	1602	1410	1732	1169	1488	1488	1537	1378	1665	1142	1431	1431	1468	1344	1590	1113		
35000	75	1550	1224	1693	953	1491	1199	1631	926	1765	649	1423	1166	1561	896	1695	623	1354	1122	1487	865	1616	595		
	80	1565	1431	1695	1162	1506	1400	1635	1135	1768	855	1440	1365	1566	1106	1698	829	1374	1330	1489	1071	1620	800		
	85	1603	1603	1701	1366	1553	1553	1641	1337	1770	1061	1496	1496	1573	1306	1700	1034	1436	1436	1500	1271	1622	1005		
	90	1675	1675	1713	1569	1625	1625	1654	1541	1772	1268	1569	1569	1589	1510	1702	1238	1507	1507	1518	1475	1625	1207		
40000	75	1591	1306	1727	1001	1529	1274	1664	975	1797	662	1459	1238	1593	945	1725	636	1389	1202	1516	914	1644	608		
	80	1611	1542	1731	1239	1552	1512	1667	1209	1799	896	1486	1477	1597	1177	1727	869	1419	1419	1521	1142	1647	841		
	85	1669	1669	1740	1465	1617	1617	1677	1436	1801	1130	1559	1559	1609	1405	1727	1102	1495	1495	1534	1370	1649	1074		
	90	1744	1744	1760	1699	1689	1689	1697	1669	1806	1357	1631	1631	1630	1630	1731	1327	1566	1566	1565	1565	1653	1295		
45000	75	1624	1385	1755	1049	1561	1353	1690	1022	1823	675	1490	1317	1618	993	1749	649	1418	1280	1539	962	1667	621		
	80	1646	1646	1760	1307	1593	1593	1695	1278	1824	936	1532	1532	1624	1246	1749	909	1466	1466	1547	1211	1668	881		
	85	1724	1724	1773	1564	1669	1669	1707	1533	1826	1197	1609	1609	1639	1502	1750	1166	1542	1542	1563	1467	1670	1134		
	90	1802	1802	1802	1802	1741	1741	1741	1741	1833	1446	1680	1680	1680	1680	1755	1414	1613	1613	1612	1612	1675	1381		
50000	75	1651	1462	1777	1095	1588	1430	1709	1069	1845	687	1517	1394	1635	1036	1768	662	1443	1357	1556	1001	1685	634		
	80	1690	1690	1785	1376	1635	1635	1717	1345	1845	975	1573	1573	1646	1313	1767	948	1505	1505	1568	1278	1685	920		
	85	1771	1771	1802	1660	1711	1711	1733	1629	1847	1257	1650	1650	1665	1597	1769	1226	1581	1581	1589	1562	1687	1193		
	90	1850	1850	1850	1850	1786	1786	1786	1786	1855	1533	1720	1720	1720	1720	1776	1501	1650	1650	1650	1650	1693	1467		
55000	75	1674	1537	1795	1139	1611	1505	1727	1109	1863	700	1541	1469	1653	1076	1785	674	1466	1431	1572	1039	1701	646		
	80	1728	1728	1806	1443	1671	1671	1735	1411	1861	1015	1608	1608	1664	1379	1782	987	1538	1538	1585	1344	1701	959		
	85	1811	1811	1828	1756	1747	1747	1758	1723	1864	1316	1684	1684	1688	1688	1784	1284	1613	1613	1614	1614	1701	1250		
	90	1890	1890	1890	1890	1824	1824	1824	1824	1874	1619	1755	1755	1754	1754	1794	1586	1681	1681	1681	1681	1709	1552		
58000	75	1687	1581	1806	1162	1624	1550	1737	1132	1872	707	1554	1514	1662	1099	1794	681	1479	1475	1581	1062	1709	653		
	80	1748	1748	1817	1483	1689	1689	1746	1451	1870	1038	1626	1626	1674	1419	1793	1011	1555	1555	1595	1383	1709	977		
	85	1832	1832	1843	1812	1767	1767	1772	1772	1873	1351	1701	1701	1702	1702	1792	1319	1630	1630	1630	1629	1708	1285		
	90	1913	1913	1912	1912	1844	1844	1844	1844	1884	1670	1773	1773	1773	1773	1804	1637	1698	1698	1698	1697	1718	1602		

Table 29. Gross cooling capacities – 130 tons eFlex™ variable speed – high capacity evaporator coil, 60Hz

CFM	Ent DB (°F)	Ambient Temperature (°F)																							
		85						95						105						115					
		61		67		73		61		67		73		61		67		73		61		67		73	
23000	75	1402	1003	1553	825	1698	635	1342	970	1489	794	1633	608	1280	937	1421	761	1561	578	1228	910	1360	733	1489	549
	80	1406	1145	1557	966	1699	775	1345	1112	1493	935	1635	747	1284	1078	1425	902	1563	717	1232	1050	1365	874	1491	687
	85	1411	1284	1560	1107	1701	914	1353	1250	1497	1076	1638	886	1293	1216	1429	1043	1566	856	1242	1187	1368	1013	1494	826
	90	1432	1424	1564	1247	1703	1052	1381	1381	1501	1216	1640	1025	1330	1330	1432	1182	1569	994	1286	1286	1370	1150	1497	963
26000	75	1452	1063	1602	860	1739	644	1388	1030	1535	829	1671	617	1323	996	1463	796	1596	587	1268	968	1398	767	1521	558
	80	1456	1223	1605	1019	1741	801	1392	1186	1540	988	1673	773	1328	1151	1468	954	1599	743	1273	1121	1403	924	1524	713
	85	1467	1379	1609	1177	1743	958	1406	1344	1544	1146	1675	929	1344	1309	1473	1112	1602	899	1292	1274	1405	1081	1526	868
	90	1508	1508	1612	1333	1745	1113	1457	1457	1548	1300	1676	1084	1401	1401	1477	1265	1604	1053	1352	1352	1412	1232	1528	1022
30000	75	1505	1139	1650	903	1782	656	1436	1105	1582	872	1707	627	1367	1069	1507	839	1631	598	1308	1039	1437	809	1552	569
	80	1512	1318	1653	1084	1785	836	1447	1283	1586	1053	1708	805	1379	1246	1512	1020	1633	776	1320	1214	1441	989	1555	746
	85	1532	1502	1657	1265	1789	1015	1472	1460	1589	1233	1711	983	1410	1410	1515	1198	1634	953	1358	1358	1445	1164	1556	922
	90	1595	1595	1663	1440	1792	1193	1541	1541	1599	1408	1712	1161	1481	1481	1526	1372	1635	1130	1423	1423	1456	1338	1556	1099
35000	75	1556	1230	1693	952	1824	670	1485	1190	1624	922	1741	639	1412	1152	1547	890	1662	610	1349	1119	1472	858	1582	581
	80	1569	1434	1696	1162	1828	877	1503	1398	1628	1132	1743	845	1431	1361	1552	1099	1662	815	1368	1327	1477	1067	1581	785
	85	1608	1608	1701	1366	1831	1084	1551	1551	1634	1334	1746	1051	1488	1488	1559	1299	1661	1019	1427	1427	1484	1263	1579	988
	90	1677	1677	1712	1569	1834	1291	1621	1621	1646	1537	1749	1258	1557	1557	1573	1502	1663	1221	1492	1492	1498	1464	1581	1187
40000	75	1595	1308	1724	999	1856	682	1525	1272	1654	970	1768	650	1449	1233	1576	938	1685	621	1382	1199	1498	906	1604	593
	80	1615	1545	1727	1236	1859	917	1549	1510	1657	1204	1772	885	1477	1462	1581	1172	1682	853	1412	1412	1503	1133	1599	823
	85	1672	1672	1737	1464	1861	1152	1613	1613	1666	1431	1774	1119	1547	1547	1591	1396	1684	1086	1481	1481	1513	1360	1599	1053
	90	1741	1741	1756	1697	1865	1382	1677	1677	1681	1657	1778	1346	1611	1611	1610	1610	1687	1308	1540	1540	1540	1540	1596	1271
45000	75	1627	1387	1750	1046	1881	694	1557	1351	1677	1016	1790	662	1479	1312	1596	984	1704	633	1409	1276	1516	951	1621	604
	80	1650	1650	1754	1305	1883	956	1589	1589	1681	1271	1793	924	1521	1521	1603	1236	1699	891	1455	1455	1524	1200	1612	861
	85	1723	1723	1768	1561	1884	1219	1660	1660	1691	1526	1794	1184	1592	1592	1615	1491	1701	1146	1521	1521	1536	1454	1610	1109
	90	1797	1797	1796	1796	1891	1470	1724	1724	1723	1723	1800	1432	1647	1647	1647	1647	1706	1394	1572	1572	1572	1572	1612	1356
50000	75	1654	1463	1770	1092	1901	706	1583	1428	1694	1062	1808	674	1505	1388	1613	1026	1719	644	1433	1351	1533	989	1635	616
	80	1691	1691	1777	1372	1901	995	1629	1629	1699	1337	1809	963	1560	1560	1621	1302	1714	930	1490	1490	1540	1265	1627	900
	85	1767	1767	1795	1658	1904	1280	1696	1696	1713	1620	1811	1242	1625	1625	1634	1583	1716	1204	1551	1551	1555	1539	1621	1165
	90	1841	1841	1841	1841	1915	1558	1764	1764	1763	1763	1818	1518	1682	1682	1681	1681	1721	1479	1598	1598	1597	1597	1626	1439
55000	75	1676	1538	1786	1134	1918	717	1606	1503	1709	1100	1823	686	1527	1463	1628	1064	1731	655	1451	1421	1546	1027	1648	628
	80	1726	1726	1797	1439	1917	1034	1661	1661	1715	1402	1823	1001	1590	1590	1635	1366	1727	968	1517	1517	1554	1329	1640	933
	85	1804	1804	1820	1752	1919	1334	1728	1728	1736	1713	1824	1300	1650	1650	1651	1651	1728	1261	1573	1573	1573	1573	1632	1222
	90	1878	1878	1878	1878	1936	1644	1795	1795	1795	1795	1834	1603	1709	1709	1709	1709	1734	1562	1618	1618	1621	1621	1636	1521
58000	75	1688	1582	1794	1157	1926	724	1618	1547	1717	1123	1831	693	1537	1505	1636	1086	1738	662	1460	1460	1553	1049	1654	635
	80	1744	1744	1808	1479	1926	1057	1677	1677	1723	1441	1832	1026	1605	1605	1643	1404	1734	987	1531	1531	1561	1367	1644	950
	85	1824	1824	1833	1808	1931	1374	1746	1746	1749	1749	1831	1334	1663	1663	1663	1663	1734	1295	1584	1584	1583	1583	1637	1255
	90	1899	1899	1899	1899	1947	1696	1812	1812	1812	1812	1842	1653	1723	1723	1722	1722	1742	1612	1632	1632	1632	1632	1641	1570

Air-Cooled, 50Hz, Standard and High Capacity Evaporator Coils

Table 30. Gross cooling capacities – 90 tons – standard evaporator coil, 50Hz

CFM	Ent DB (°F)	Ambient Temperature (°F)																							
		85						95						105						115					
		Entering Wet Bulb (°F)			Entering Wet Bulb (°F)			Entering Wet Bulb (°F)			Entering Wet Bulb (°F)			Entering Wet Bulb (°F)			Entering Wet Bulb (°F)			Entering Wet Bulb (°F)					
		61	67	73	61	67	73	61	67	73	61	67	73	61	67	73	61	67	73						
16000	75	793	590	875	474	959	355	759	571	839	458	920	340	726	553	802	441	879	323	693	535	764	425	836	307
	80	797	677	878	566	960	445	765	659	843	549	922	430	732	641	806	533	881	414	699	623	768	516	839	397
	85	806	768	879	654	963	536	775	750	844	637	925	520	738	738	808	619	884	504	709	709	770	600	842	487
	90	831	831	884	741	965	625	804	804	850	724	925	611	775	775	814	706	885	593	746	746	776	687	843	575
20000	75	835	653	916	514	997	367	800	638	878	498	956	351	764	615	838	481	912	335	727	596	797	463	866	318
	80	844	763	918	625	1000	478	809	744	880	607	959	463	774	725	841	588	916	446	738	705	799	569	871	430
	85	861	861	923	731	1002	589	831	831	886	713	962	574	800	800	847	694	917	558	767	767	806	675	872	540
	90	903	903	931	839	1004	696	872	872	895	821	964	679	840	840	856	802	921	661	805	805	812	788	877	642
25000	75	873	726	949	561	1029	379	836	707	908	544	986	364	797	687	865	525	939	348	758	666	821	505	892	331
	80	879	879	954	690	1032	516	847	847	914	671	990	501	813	813	871	652	944	484	777	777	828	631	897	468
	85	924	924	961	821	1034	650	891	891	922	802	992	633	855	855	880	783	946	614	818	818	837	762	900	595
	90	967	967	967	967	1037	777	933	933	933	933	996	759	897	897	897	897	951	741	859	859	858	858	905	722
30000	75	900	795	973	599	1052	391	862	775	931	580	1006	375	821	754	886	560	958	359	780	733	840	540	910	343
	80	923	923	978	750	1055	553	888	888	937	731	1008	540	852	852	893	711	961	521	813	813	848	690	914	502
	85	969	969	988	906	1056	703	934	934	948	887	1013	685	896	896	905	867	966	666	856	856	861	846	918	647
	90	1013	1013	1013	1013	1060	854	977	977	977	977	1018	836	938	938	938	938	972	817	898	898	897	897	925	798
33000	75	914	834	984	620	1062	397	875	814	941	601	1016	382	834	793	896	581	967	366	786	786	849	560	918	349
	80	944	944	990	785	1064	575	908	908	948	766	1019	557	870	870	904	746	971	538	830	830	857	724	922	519
	85	991	991	1002	956	1066	734	954	954	962	936	1022	716	915	915	919	916	975	697	874	874	875	875	927	677
	90	1035	1035	1035	1035	1071	899	998	998	998	997	1028	881	957	957	957	957	982	862	916	916	915	915	934	841
36000	75	926	872	993	640	1071	404	877	877	950	621	1024	388	839	839	904	601	974	372	800	800	857	579	925	356
	80	962	962	1000	819	1073	591	925	925	958	800	1027	574	886	886	913	779	979	554	845	845	866	758	930	535
	85	1009	1009	1015	1004	1075	764	972	972	974	974	1030	746	931	931	931	931	983	727	889	889	889	889	934	706
	90	1054	1054	1053	1053	1081	943	1015	1015	1015	1015	1037	924	974	974	974	974	991	905	931	931	931	931	938	898
40000	75	933	933	1004	666	1081	412	896	896	960	647	1033	396	857	857	913	626	983	380	816	816	865	604	933	364
	80	983	983	1011	863	1083	613	945	945	968	844	1036	595	904	904	923	822	988	575	862	862	876	800	938	555
	85	1030	1030	1031	1031	1084	803	991	991	991	991	1039	785	949	949	949	949	991	765	907	907	906	906	942	744
	90	1075	1075	1074	1074	1093	1000	1035	1035	1035	1035	1034	1034	1042	992	992	992	992	991	991	948	948	947	947	947

Table 31. Gross cooling capacities – 90 tons eFlex™ variable speed – standard evaporator coil, 50Hz

CFM	Ent DB (°F)	Ambient Temperature (°F)																							
		85						95						105						115					
		Entering Wet Bulb (°F)			Entering Wet Bulb (°F)			Entering Wet Bulb (°F)			Entering Wet Bulb (°F)			Entering Wet Bulb (°F)			Entering Wet Bulb (°F)			Entering Wet Bulb (°F)					
		61	67	73	61	67	73	61	67	73	61	67	73	61	67	73	61	67	73						
16000	75	838	614	925	497	1006	374	800	593	883	478	960	355	765	574	839	458	909	334	738	559	797	438	856	314
	80	842	702	928	589	1007	464	805	681	886	569	961	445	770	662	843	549	911	425	742	646	800	529	858	404
	85	851	793	929	679	1009	555	814	772	888	659	963	536	779	752	844	637	913	515	748	734	801	615	860	493
	90	870	870	934	767	1011	645	838	838	893	746	965	625	806	806	850	723	914	605	774	774	806	701	861	583
20000	75	885	679	968	537	1038	382	844	657	923	517	988	363	803	635	874	496	934	342	766	616	825	475	877	321
	80	893	789	970	650	1039	493	853	767	925	628	990	474	812	745	876	605	935	453	774	724	827	582	877	431
	85	904	904	974	756	1040	604	869	869	930	734	991	584	832	832	882	711	936	563	795	795	832	687	878	542
	90	946	946	981	864	1041	713	910	910	930	842	992	691	870	870	889	818	937	668	828	828	840	794	879	643
25000	75	926	754	1002	581	1063	391	882	731	952	562	1009	372	836	707	899	540	951	351	792	684	846	516	891	330
	80	935	896	1004	713	1065	528	893	867	956	691	1011	508	846	846	904	667	953	487	805	805	851	642	891	465
	85	970	970	1010	844	1066	664	930	930	962	821	1012	642	886	886	910	797	954	617	840	840	856	771	893	592
	90	1009	1009	1017	978	1069	791	967	967	967	967	1015	768	920	920	919	919	957	743	868	868	868	868	894	717
30000	75	955	822	1021	621	1081	401	909	799	971	599	1024	381	860	773	917	574	963	360	812	749	861	549	900	339
	80	971	971	1025	772	1084	563	929	929	975	749	1027	543	884	884	921	724	965	523	837	837	865	698	902	498
	85	1012	1012	1031	926	1087	716	968	968	982	903	1028	692	920	920	928	877	967	667	867	867	871	850	902	640
	90	1046	1046	1046	1046	1092	867	999	999	999	999	1033	843	947	947	947	947	947	970	816	891	890	890	902	787
33000	75	968	862	1031	641	1089	407	921	837	980	619	1032	387	871	812	924	594	970	366	819	792	867	568	905	345
	80	991	991	1034	805	1092	584	948	948	983	782	1033	564	900	900	928	757	971	539	851	851	870	730	906	513
	85	1030	1030	1041	973	1097	747	983	983	990	949	1036	722	932	932	935	923	972	696	877	877	877	877	905	668
	90	1065	1065	1065	1065	1104	912	1015	1015	1015	1015	1042	886	960	960	960	960	960	976	859	899	899	899	906	829
36000	75	974	917	1038	661	1096	412	928	885	986	638	1038	393	874	874	930	612	975	372	827	827	872	586	910	350
	80	1008	1008	1040	838	1099	603	963	963	989	814	1039	579	913	913	933	788	976	554	861	861	875	761	910	527
	85	1044	1044	1051	1020	1105	776	996	996	999	990	1043	751	942	942	943	943	977	724	886	886	885	885	907	695
	90	1084	1084	1083	1083	1114	956	1030	1030	1030	1030	1050	929	971	971	971	971	978	922	906	906	905	905	908	905
40000	75	989	951	1045	685	1104	420	938	938	993	662	1044	400	890	890	936	636	980	379	840	840	878	609	914	358
	80	1025	1025	1049	881	1108	624	978	978	996	856	1046	599	926	926	939	829	981	573	871	871	879	801	913	545
	85	1061	1061	1063	1059	1114	815	1011	1011	1010	1010	1050	789	955	955	955	955	982	761	896	896	895	895	910	731
	90	1105	1105	1104	1104	1118	1039	1047	1047	1047	1047	1055	1000	984	984	983	983	983	983	912	912	912	912	911	911

Table 32. Gross cooling capacities – 105 tons – standard evaporator coil, 50Hz

CFM	Ent DB (°F)	Ambient Temperature (°F)																							
		85						95						105						115					
		Entering Wet Bulb (°F)						Entering Wet Bulb (°F)						Entering Wet Bulb (°F)						Entering Wet Bulb (°F)					
		61	67	73	79	85	91	61	67	73	79	85	91	61	67	73	79	85	91	61	67	73	79	85	91
19000	75	931	701	1024	560	1117	413	893	681	983	541	1071	395	852	659	937	521	1024	377	810	636	892	501	974	358
	80	939	809	1028	671	1119	523	900	789	987	652	1074	505	860	765	942	632	1027	486	819	743	896	612	978	467
	85	970	929	1031	777	1122	633	914	899	990	757	1077	615	875	785	946	736	1030	596	838	838	900	714	981	577
	90	985	985	1037	884	1122	743	953	952	996	864	1078	723	918	918	951	842	1032	703	880	879	906	819	983	681
23000	75	973	765	1063	600	1153	425	932	744	1019	581	1105	407	888	721	971	561	1055	389	844	702	920	542	1001	369
	80	983	896	1065	731	1156	556	992	893	1022	714	1109	538	899	850	974	693	1059	520	878	835	924	665	1007	501
	85	1006	1006	1071	855	1158	687	971	971	1028	835	1111	670	933	933	981	812	1062	650	893	893	935	790	1010	628
	90	1053	1053	1081	984	1160	813	1017	1017	1038	963	1114	793	978	978	991	941	1065	771	938	938	945	918	1013	749
28000	75	1010	842	1095	646	1184	437	966	821	1048	626	1135	420	920	795	998	604	1088	398	874	771	949	581	1027	382
	80	1025	998	1099	796	1187	595	980	980	1052	775	1137	583	940	940	1003	753	1085	563	898	897	955	730	1031	540
	85	1068	1067	1108	948	1189	749	1029	1029	1063	927	1141	727	987	987	1015	904	1089	706	946	946	965	881	1034	684
	90	1116	1116	1116	1115	1192	896	1077	1077	1077	1075	1145	876	1035	1035	1035	1034	1093	854	991	991	990	989	1038	830
33000	75	1037	912	1119	685	1207	449	989	889	1071	664	1156	432	943	864	1020	642	1103	414	896	840	969	617	1048	394
	80	1063	1062	1123	860	1208	636	1023	1022	1076	838	1159	614	979	979	1026	815	1106	593	936	936	975	793	1049	570
	85	1114	1114	1135	1038	1210	804	1073	1073	1089	1016	1161	784	1030	1030	1041	993	1108	761	984	984	990	968	1052	738
	90	1163	1163	1163	1162	1215	976	1122	1122	1121	1121	1166	956	1077	1077	1076	1076	1113	934	1028	1028	1028	1027	1057	910
38000	75	1059	981	1137	722	1226	460	1071	968	1088	700	1172	443	965	932	1036	677	1117	425	913	913	985	652	1059	406
	80	1097	1097	1144	921	1226	667	1056	1056	1095	899	1175	643	1011	1011	1045	875	1121	622	965	965	991	850	1063	598
	85	1150	1149	1158	1124	1226	857	1107	1107	1112	1101	1177	837	1062	1062	1063	1063	1123	814	1013	1013	1013	1013	1065	790
	90	1198	1198	1198	1197	1234	1055	1155	1155	1155	1154	1181	1033	1108	1108	1107	1107	1129	1011	1057	1057	1056	1056	1072	987
43000	75	1070	1068	1151	756	1238	472	1028	1027	1101	734	1185	455	982	982	1049	711	1129	436	936	936	996	686	1070	417
	80	1125	1125	1159	980	1239	696	1082	1082	1110	957	1188	672	1036	1036	1058	933	1133	650	988	988	1004	909	1074	625
	85	1178	1177	1178	1178	1240	910	1134	1134	1134	1134	1189	889	1087	1087	1086	1086	1134	865	1036	1036	1035	1035	1075	841
	90	1228	1228	1227	1227	1250	1132	1182	1182	1180	1180	1196	1109	1132	1132	1131	1131	1143	1087	1079	1079	1078	1078	1078	1077
45000	75	1080	1078	1156	770	1243	476	1037	1036	1106	748	1190	459	990	990	1054	724	1133	441	944	944	1000	699	1074	422
	80	1135	1135	1165	1003	1244	707	1091	1091	1116	981	1192	683	1045	1045	1063	957	1136	661	996	996	1009	930	1077	636
	85	1186	1186	1187	1187	1245	931	1143	1143	1143	1143	1193	909	1095	1095	1094	1094	1138	885	1044	1044	1043	1043	1079	861
	90	1238	1238	1238	1237	1256	1162	1191	1191	1189	1189	1202	1140	1141	1141	1140	1140	1140	1137	1087	1087	1086	1086	1085	1084



Performance Data

Table 33. Gross cooling capacities – 105 tons eFlex™ variable speed – standard evaporator coil, 50Hz

CFM	Ent DB (°F)	Ambient Temperature (°F)																							
		85						95						105						115					
		Entering Wet Bulb (°F)			Entering Wet Bulb (°F)			Entering Wet Bulb (°F)			Entering Wet Bulb (°F)			Entering Wet Bulb (°F)			Entering Wet Bulb (°F)			Entering Wet Bulb (°F)					
		61	67	73	61	67	73	61	67	73	61	67	73	61	67	73	61	67	73						
19000	75	972	722	1066	578	1151	426	928	698	1017	556	1098	405	885	675	966	533	1041	382	851	657	918	512	983	361
	80	979	831	1069	690	1153	536	935	806	1020	667	1100	515	892	782	968	643	1043	492	856	763	920	621	985	469
	85	990	942	1071	799	1155	645	946	915	1023	774	1102	624	906	883	972	749	1045	601	870	854	924	725	986	578
	90	1020	1020	1078	905	1156	755	981	981	1029	881	1103	733	941	941	979	855	1046	708	903	903	930	831	987	683
23000	75	1015	787	1104	618	1180	434	967	762	1052	595	1125	413	919	737	997	571	1064	391	878	715	945	549	1003	369
	80	1025	918	1107	749	1181	565	978	892	1054	725	1125	544	930	866	1000	699	1065	521	886	842	947	674	1002	498
	85	1043	1043	1112	875	1183	696	1001	1001	1060	850	1126	675	957	957	1006	824	1066	650	915	915	952	799	1002	625
	90	1089	1089	1119	1003	1185	824	1045	1045	1068	978	1127	799	999	999	1011	955	1066	772	952	952	960	916	1001	745
28000	75	1053	863	1136	663	1205	444	1003	837	1080	640	1145	423	950	810	1022	614	1083	401	904	785	965	591	1018	378
	80	1065	1023	1138	814	1206	602	1018	987	1084	789	1146	580	969	949	1026	762	1081	556	920	920	970	736	1016	533
	85	1104	1104	1144	966	1207	757	1058	1058	1090	940	1146	732	1009	1009	1033	913	1081	705	959	959	975	885	1013	676
	90	1146	1146	1153	1111	1213	905	1098	1098	1101	1073	1149	878	1044	1044	1044	1044	1044	850	986	986	986	986	1013	821
33000	75	1081	935	1155	704	1222	454	1029	907	1099	678	1160	433	974	879	1039	652	1094	410	924	853	981	625	1029	388
	80	1101	1101	1159	876	1225	639	1053	1053	1103	850	1159	615	1002	1002	1044	823	1093	589	952	952	984	795	1025	565
	85	1146	1146	1165	1051	1228	812	1096	1096	1110	1025	1161	784	1042	1042	1051	997	1093	756	985	985	988	951	1021	726
	90	1185	1185	1184	1184	1235	985	1131	1131	1131	1131	1167	956	1072	1072	1072	1072	1095	926	1008	1008	1008	1008	1020	894
38000	75	1103	1003	1170	739	1235	464	1049	975	1113	713	1171	442	992	945	1052	685	1103	420	940	905	991	657	1037	398
	80	1133	1133	1173	934	1239	672	1083	1083	1117	908	1171	647	1029	1029	1056	880	1102	618	975	975	993	851	1031	589
	85	1174	1174	1184	1136	1244	865	1121	1121	1126	1094	1174	836	1063	1063	1065	1045	1101	806	1000	1000	1000	998	1026	774
	90	1219	1219	1218	1218	1252	1063	1158	1158	1158	1158	1180	1033	1092	1092	1092	1092	1105	1001	1020	1020	1020	1020	1026	961
43000	75	1117	1070	1182	772	1246	474	1064	1030	1124	746	1180	452	1006	1006	1062	717	1111	430	954	954	999	689	1043	408
	80	1156	1156	1185	991	1251	702	1104	1104	1126	964	1180	673	1048	1048	1064	935	1109	644	989	989	1000	904	1036	613
	85	1198	1198	1201	1187	1256	917	1141	1141	1142	1142	1184	887	1079	1079	1079	1079	1109	855	1012	1012	1012	1012	1031	822
	90	1245	1245	1245	1245	1267	1139	1179	1179	1179	1179	1189	1115	1108	1108	1107	1107	1112	1059	1029	1029	1029	1029	1029	1030
45000	75	1124	1087	1185	785	1250	478	1071	1046	1127	759	1182	456	1013	1013	1065	730	1114	434	960	960	1002	701	1046	412
	80	1164	1164	1189	1014	1255	713	1111	1111	1129	986	1183	684	1054	1054	1067	956	1111	654	994	994	1000	931	1037	623
	85	1207	1207	1208	1208	1260	937	1147	1147	1148	1148	1187	907	1084	1084	1084	1084	1111	875	1016	1016	1016	1016	1032	840
	90	1254	1254	1254	1254	1267	1184	1186	1186	1186	1186	1194	1132	1112	1112	1112	1112	1112	1112	1115	1076	1031	1031	1030	1030

Table 34. Gross cooling capacities – 120 tons – standard evaporator coil, 50Hz

CFM	Ent DB (°F)	Ambient Temperature (°F)																									
		85						95						105						115							
		Entering Wet Bulb (°F)						Entering Wet Bulb (°F)						Entering Wet Bulb (°F)						Entering Wet Bulb (°F)							
		61	67	73	79	85	91	61	67	73	79	85	91	61	67	73	79	85	91	61	67	73	79	85	91		
		CAP	SHC	CAP	SHC	CAP	SHC	CAP	SHC	CAP	SHC	CAP	SHC	CAP	SHC	CAP	SHC	CAP	SHC	CAP	SHC	CAP	SHC				
21000	75	1033	770	1143	620	1261	467	1411	529	1544	144	1248	816	1355	510	1097	1097	1190	791	1293	489	1046	1046	1128	764	1226	467
	80	1037	886	1146	739	1262	585	1413	771	1544	144	1248	816	1355	510	1097	1097	1190	791	1293	489	1046	1046	1128	764	1226	467
	85	1042	1013	1147	858	1264	702	1413	771	1544	144	1248	816	1355	510	1097	1097	1190	791	1293	489	1046	1046	1128	764	1226	467
	90	1082	1082	1153	972	1267	820	1413	771	1544	144	1248	816	1355	510	1097	1097	1190	791	1293	489	1046	1046	1128	764	1226	467
26000	75	1086	856	1198	670	1313	482	1413	771	1544	144	1248	816	1355	510	1097	1097	1190	791	1293	489	1046	1046	1128	764	1226	467
	80	1096	995	1198	818	1314	626	1413	771	1544	144	1248	816	1355	510	1097	1097	1190	791	1293	489	1046	1046	1128	764	1226	467
	85	1119	1119	1205	956	1317	770	1413	771	1544	144	1248	816	1355	510	1097	1097	1190	791	1293	489	1046	1046	1128	764	1226	467
	90	1176	1176	1217	1098	1318	914	1413	771	1544	144	1248	816	1355	510	1097	1097	1190	791	1293	489	1046	1046	1128	764	1226	467
31000	75	1125	927	1236	717	1349	495	1413	771	1544	144	1248	816	1355	510	1097	1097	1190	791	1293	489	1046	1046	1128	764	1226	467
	80	1127	1127	1238	885	1351	665	1413	771	1544	144	1248	816	1355	510	1097	1097	1190	791	1293	489	1046	1046	1128	764	1226	467
	85	1188	1188	1248	1049	1354	834	1413	771	1544	144	1248	816	1355	510	1097	1097	1190	791	1293	489	1046	1046	1128	764	1226	467
	90	1248	1248	1247	1247	1356	997	1413	771	1544	144	1248	816	1355	510	1097	1097	1190	791	1293	489	1046	1046	1128	764	1226	467
36000	75	1158	1000	1264	761	1375	507	1413	771	1544	144	1248	816	1355	510	1097	1097	1190	791	1293	489	1046	1046	1128	764	1226	467
	80	1179	1179	1268	949	1377	702	1413	771	1544	144	1248	816	1355	510	1097	1097	1190	791	1293	489	1046	1046	1128	764	1226	467
	85	1242	1242	1282	1138	1379	895	1413	771	1544	144	1248	816	1355	510	1097	1097	1190	791	1293	489	1046	1046	1128	764	1226	467
	90	1303	1303	1303	1303	1384	1078	1413	771	1544	144	1248	816	1355	510	1097	1097	1190	791	1293	489	1046	1046	1128	764	1226	467
41000	75	1185	1069	1283	803	1395	518	1413	771	1544	144	1248	816	1355	510	1097	1097	1190	791	1293	489	1046	1046	1128	764	1226	467
	80	1221	1221	1292	1011	1398	737	1413	771	1544	144	1248	816	1355	510	1097	1097	1190	791	1293	489	1046	1046	1128	764	1226	467
	85	1286	1286	1309	1224	1399	949	1413	771	1544	144	1248	816	1355	510	1097	1097	1190	791	1293	489	1046	1046	1128	764	1226	467
	90	1347	1347	1346	1346	1408	1156	1413	771	1544	144	1248	816	1355	510	1097	1097	1190	791	1293	489	1046	1046	1128	764	1226	467
46000	75	1188	1188	1301	839	1411	529	1413	771	1544	144	1248	816	1355	510	1097	1097	1190	791	1293	489	1046	1046	1128	764	1226	467
	80	1255	1255	1311	1069	1413	771	1413	771	1544	144	1248	816	1355	510	1097	1097	1190	791	1293	489	1046	1046	1128	764	1226	467
	85	1321	1321	1333	1307	1416	1001	1413	771	1544	144	1248	816	1355	510	1097	1097	1190	791	1293	489	1046	1046	1128	764	1226	467
	90	1383	1383	1382	1382	1429	1231	1413	771	1544	144	1248	816	1355	510	1097	1097	1190	791	1293	489	1046	1046	1128	764	1226	467
51000	75	1215	1215	1316	873	1424	539	1413	771	1544	144	1248	816	1355	510	1097	1097	1190	791	1293	489	1046	1046	1128	764	1226	467
	80	1284	1284	1328	1126	1425	807	1413	771	1544	144	1248	816	1355	510	1097	1097	1190	791	1293	489	1046	1046	1128	764	1226	467
	85	1349	1349	1354	1354	1430	1052	1413	771	1544	144	1248	816	1355	510	1097	1097	1190	791	1293	489	1046	1046	1128	764	1226	467
	90	1413	1413	1412	1412	1447	1305	1413	771	1544	144	1248	816	1355	510	1097	1097	1190	791	1293	489	1046	1046	1128	764	1226	467
54000	75	1229	1229	1323	893	1431	545	1413	771	1544	144	1248	816	1355	510	1097	1097	1190	791	1293	489	1046	1046	1128	764	1226	467
	80	1299	1299	1336	1159	1432	823	1413	771	1544	144	1248	816	1355	510	1097	1097	1190	791	1293	489	1046	1046	1128	764	1226	467
	85	1364	1364	1366	1366	1438	1081	1413	771	1544	144	1248	816	1355	510	1097	1097	1190	791	1293	489	1046	1046	1128	764	1226	467
	90	1430	1430	1429	1429	1428	1428	1413	771	1544	144	1248	816	1355	510	1097	1097	1190	791	1293	489	1046	1046	1128	764	1226	467

Table 35. Gross cooling capacities – 120 tons eFlex™ variable speed – standard evaporator coil, 50Hz

CFM	Ent DB (°F)	Ambient Temperature (°F)																							
		85						95						105						115					
		Entering Wet Bulb (°F)		73		67		Entering Wet Bulb (°F)		73		67		Entering Wet Bulb (°F)		73		67		Entering Wet Bulb (°F)		73		67	
CAP	SHC	CAP	SHC	CAP	SHC	CAP	SHC	CAP	SHC	CAP	SHC	CAP	SHC	CAP	SHC	CAP	SHC	CAP	SHC	CAP	SHC	CAP	SHC	CAP	SHC
21000	75	1078	795	1194	643	1309	486	1033	771	1144	620	1255	464	984	745	1090	595	1193	440	935	719	1033	570	1129	414
	80	1083	912	1197	763	1310	605	1039	887	1148	740	1256	582	990	861	1094	715	1196	558	942	834	1037	689	1130	531
	85	1086	1039	1198	882	1312	723	1047	1008	1150	858	1259	700	1003	974	1094	832	1198	675	958	939	1039	805	1133	649
	90	1121	1121	1203	998	1315	840	1084	1084	1155	973	1261	817	1043	1043	1102	946	1201	792	1000	1000	1047	919	1134	766
26000	75	1135	879	1250	694	1357	499	1086	853	1197	670	1298	476	1033	825	1138	644	1233	452	979	797	1076	618	1161	425
	80	1146	1022	1254	840	1358	644	1099	997	1199	816	1300	621	1047	969	1141	789	1234	595	989	942	1079	761	1163	568
	85	1162	1162	1256	982	1360	787	1121	1121	1204	957	1302	764	1076	1076	1146	929	1236	739	1028	1028	1085	900	1164	713
	90	1219	1219	1267	1123	1361	931	1177	1177	1216	1098	1302	909	1130	1130	1150	1082	1236	881	1079	1079	1093	1040	1164	850
31000	75	1178	955	1289	740	1387	509	1127	929	1233	716	1325	486	1071	900	1170	690	1256	462	1014	871	1102	663	1181	435
	80	1189	1134	1291	911	1389	679	1142	1099	1235	885	1326	656	1081	1081	1173	856	1257	630	1031	1031	1107	826	1181	603
	85	1234	1234	1299	1074	1392	849	1189	1189	1244	1048	1327	826	1138	1138	1183	1020	1257	798	1084	1084	1117	989	1181	771
	90	1292	1292	1307	1247	1394	1015	1244	1244	1244	1244	1329	988	1191	1191	1190	1190	1259	959	1132	1132	1131	1131	1183	927
36000	75	1213	1033	1317	783	1412	520	1159	1001	1257	760	1343	496	1101	971	1192	732	1271	471	1041	941	1123	703	1194	444
	80	1227	1227	1319	974	1416	716	1180	1180	1261	947	1345	690	1128	1128	1197	918	1272	664	1073	1073	1129	892	1193	636
	85	1288	1288	1330	1162	1416	912	1239	1239	1273	1135	1346	884	1184	1184	1209	1106	1273	854	1124	1124	1141	1074	1194	822
	90	1343	1343	1342	1342	1423	1095	1291	1291	1290	1290	1353	1066	1231	1231	1231	1231	1277	1035	1164	1164	1163	1163	1197	1002
41000	75	1240	1097	1336	824	1432	531	1186	1069	1274	801	1358	506	1119	1052	1208	771	1283	480	1060	1008	1137	740	1204	453
	80	1269	1269	1341	1034	1435	751	1220	1220	1281	1007	1362	725	1164	1164	1215	977	1284	700	1105	1105	1144	945	1203	669
	85	1329	1329	1354	1245	1437	965	1277	1277	1295	1218	1364	936	1218	1218	1229	1187	1285	905	1152	1152	1158	1131	1203	872
	90	1382	1382	1382	1382	1447	1173	1325	1325	1324	1324	1373	1143	1260	1260	1260	1260	1294	1110	1188	1188	1188	1188	1211	1076
46000	75	1254	1182	1351	862	1447	541	1201	1142	1289	835	1371	516	1132	1132	1221	805	1293	489	1074	1074	1149	773	1211	462
	80	1303	1303	1357	1091	1450	787	1251	1251	1297	1064	1374	760	1193	1193	1229	1034	1294	730	1129	1129	1156	1000	1211	702
	85	1359	1359	1374	1326	1454	1018	1304	1304	1312	1284	1378	987	1241	1241	1244	1230	1297	955	1170	1170	1172	1172	1212	921
	90	1418	1418	1417	1417	1467	1248	1354	1354	1353	1353	1379	1257	1285	1285	1284	1284	1302	1203	1209	1209	1208	1208	1220	1145
51000	75	1265	1265	1363	895	1459	551	1214	1214	1301	868	1382	525	1156	1156	1232	838	1301	498	1095	1095	1157	805	1218	471
	80	1329	1329	1370	1146	1462	818	1275	1275	1309	1119	1384	793	1214	1214	1240	1088	1302	761	1148	1148	1161	1073	1217	727
	85	1386	1386	1394	1380	1468	1068	1326	1326	1329	1329	1390	1037	1259	1259	1261	1261	1308	1004	1186	1186	1186	1186	1221	969
	90	1449	1449	1448	1448	1472	1356	1381	1381	1380	1380	1391	1305	1307	1307	1306	1306	1306	1306	1226	1226	1225	1225	1225	1225
54000	75	1280	1280	1369	915	1466	557	1227	1227	1306	887	1388	531	1168	1168	1237	857	1305	504	1106	1106	1162	824	1222	476
	80	1342	1342	1377	1179	1468	839	1287	1287	1315	1151	1389	809	1225	1225	1249	1145	1307	776	1156	1156	1167	1092	1220	742
	85	1401	1401	1406	1406	1476	1098	1337	1337	1339	1339	1397	1067	1269	1269	1269	1269	1313	1033	1193	1193	1193	1193	1225	997
	90	1465	1465	1464	1464	1484	1385	1395	1395	1394	1394	1393	1393	1318	1318	1318	1318	1317	1317	1234	1234	1233	1233	1233	1233

Table 36. Gross cooling capacities – 130 tons – standard evaporator coil, 50Hz

CFM	Ent DB (°F)	Ambient Temperature (°F)																									
		85						95						105						115							
		Entering Wet Bulb (°F)			Entering Wet Bulb (°F)			Entering Wet Bulb (°F)			Entering Wet Bulb (°F)			Entering Wet Bulb (°F)			Entering Wet Bulb (°F)			Entering Wet Bulb (°F)							
		61	67	73	61	67	73	61	67	73	61	67	73	61	67	73	61	67	73								
	75	1182	881	1304	707	1426	527	1426	527	1130	855	1252	683	1371	506	1078	827	1195	658	1310	482	1024	798	1135	631	1244	457
	80	1187	1019	1307	843	1427	662	1139	994	1256	819	1373	640	1088	959	1200	794	1313	616	1034	930	1054	930	1140	767	1247	591
23000	85	1199	1149	1307	978	1429	796	1154	1123	1257	953	1376	774	1098	1098	1201	926	1316	750	1054	1054	1142	897	1251	724		
	90	1238	1238	1314	1109	1431	930	1199	1199	1264	1084	1378	907	1155	1155	1209	1056	1319	883	1108	1108	1151	1027	1254	857		
	75	1215	932	1338	738	1457	536	1165	906	1285	715	1401	515	1110	877	1225	689	1338	491	1054	848	1163	662	1269	465		
	80	1225	1082	1342	891	1459	687	1176	1055	1289	867	1403	666	1122	1027	1230	841	1341	642	1067	997	1168	814	1273	616		
26000	85	1238	1238	1344	1040	1461	838	1197	1197	1291	1014	1406	816	1151	1151	1234	987	1344	792	1103	1103	1172	957	1276	766		
	90	1298	1298	1352	1187	1463	987	1256	1256	1301	1161	1408	965	1209	1209	1244	1134	1345	941	1159	1159	1184	1104	1277	912		
	75	1254	998	1374	778	1490	547	1202	971	1318	754	1431	526	1145	952	1257	728	1366	502	1086	911	1192	701	1295	476		
	80	1268	1170	1375	953	1492	720	1217	1143	1320	927	1434	698	1162	1114	1259	899	1370	674	1105	1084	1194	869	1300	648		
30000	85	1302	1302	1382	1118	1494	892	1258	1258	1328	1093	1436	869	1208	1208	1268	1065	1372	845	1156	1156	1204	1035	1302	819		
	90	1363	1363	1394	1288	1495	1061	1318	1318	1341	1262	1437	1037	1268	1268	1283	1234	1374	1011	1214	1214	1214	1213	1305	982		
	75	1292	1076	1407	825	1521	560	1239	1048	1350	801	1460	538	1179	1018	1286	775	1393	515	1118	987	1218	748	1320	489		
	80	1312	1277	1409	1021	1524	759	1254	1254	1353	995	1462	737	1202	1202	1290	966	1397	713	1148	1148	1223	936	1324	687		
35000	85	1365	1365	1419	1213	1525	959	1318	1318	1363	1187	1463	935	1266	1266	1302	1159	1398	909	1209	1209	1236	1128	1326	879		
	90	1427	1427	1426	1426	1529	1147	1379	1379	1378	1378	1467	1121	1326	1326	1325	1325	1402	1095	1267	1267	1266	1266	1330	1065		
	75	1323	1150	1432	870	1545	572	1268	1122	1371	847	1483	550	1207	1092	1306	818	1414	527	1144	1060	1236	787	1339	501		
	80	1349	1349	1436	1086	1548	797	1300	1300	1378	1060	1484	775	1246	1246	1314	1031	1417	751	1189	1189	1245	1000	1343	725		
40000	85	1414	1414	1448	1305	1549	1018	1365	1365	1392	1279	1484	992	1310	1310	1330	1250	1418	965	1250	1250	1262	1219	1344	936		
	90	1477	1477	1476	1476	1557	1232	1426	1426	1425	1425	1490	1204	1370	1370	1369	1369	1423	1177	1308	1308	1307	1307	1350	1147		
	75	1348	1222	1451	912	1565	584	1292	1194	1390	885	1501	562	1231	1163	1324	856	1431	538	1166	1130	1253	824	1354	513		
	80	1388	1388	1457	1150	1567	835	1338	1338	1398	1123	1501	812	1282	1282	1334	1094	1432	791	1222	1222	1264	1062	1357	761		
45000	85	1454	1454	1473	1395	1570	1075	1403	1403	1416	1368	1502	1048	1346	1346	1354	1339	1434	1021	1283	1283	1286	1286	1359	990		
	90	1519	1519	1519	1519	1579	1314	1463	1463	1462	1462	1510	1286	1405	1405	1404	1404	1440	1257	1340	1340	1339	1339	1366	1227		
	75	1369	1292	1468	949	1581	595	1308	1273	1406	922	1516	573	1243	1243	1339	892	1445	550	1182	1182	1266	859	1367	524		
	80	1421	1421	1475	1212	1582	875	1369	1369	1415	1185	1515	849	1311	1311	1350	1155	1446	821	1249	1249	1279	1123	1369	790		
50000	85	1487	1487	1496	1482	1586	1130	1433	1433	1437	1437	1516	1102	1375	1375	1376	1376	1446	1074	1310	1310	1309	1309	1371	1044		
	90	1555	1555	1555	1555	1598	1394	1495	1495	1494	1494	1528	1365	1433	1433	1432	1432	1456	1336	1365	1365	1365	1365	1380	1304		
	75	1378	1378	1481	985	1594	606	1325	1325	1419	957	1528	584	1267	1267	1351	927	1456	561	1204	1204	1277	894	1378	535		
	80	1448	1448	1490	1272	1596	905	1395	1395	1429	1245	1527	878	1336	1336	1364	1215	1457	850	1271	1271	1292	1182	1379	819		
55000	85	1516	1516	1518	1518	1600	1185	1459	1459	1458	1458	1528	1156	1399	1399	1398	1398	1457	1127	1332	1332	1331	1331	1381	1096		
	90	1585	1585	1585	1585	1614	1472	1522	1522	1522	1522	1543	1443	1457	1457	1456	1456	1455	1455	1386	1386	1386	1386	1385	1385		
	75	1392	1392	1488	1005	1602	612	1339	1339	1425	978	1535	591	1280	1280	1357	948	1462	567	1216	1216	1283	914	1383	542		
	80	1462	1462	1498	1307	1603	922	1408	1408	1437	1280	1533	895	1348	1348	1371	1250	1463	867	1283	1283	1299	1216	1385	835		
58000	85	1532	1531	1531	1531	1608	1216	1472	1472	1471	1471	1535	1187	1411	1411	1411	1411	1463	1158	1343	1343	1343	1343	1386	1126		
	90	1601	1601	1600	1600	1623	1518	1537	1537	1536	1536	1535	1535	1469	1469	1469	1469	1469	1468	1468	1468	1468	1468	1397	1397		

Table 37. Gross cooling capacities – 130 tons eFlex™ variable speed – standard evaporator coil, 50Hz

CFM	Ent DB (°F)	Ambient Temperature (°F)																							
		85				95				105				115											
		Entering Wet Bulb (°F)				Entering Wet Bulb (°F)				Entering Wet Bulb (°F)				Entering Wet Bulb (°F)											
		61	67	73	73	61	67	73	73	61	67	73	73	61	67	73	73								
23000	75	1226	904	1351	728	1468	544	1171	876	1295	702	1408	519	1116	846	1233	674	1340	492	1063	818	1171	647	1269	465
	80	1229	1038	1355	865	1469	679	1178	1009	1298	839	1409	654	1123	979	1237	810	1342	627	1070	950	1175	782	1271	599
	85	1242	1174	1356	1001	1471	813	1188	1147	1301	974	1411	788	1138	1108	1238	944	1344	761	1090	1071	1177	914	1273	732
	90	1276	1276	1361	1133	1472	947	1233	1233	1306	1105	1413	922	1185	1185	1246	1075	1345	894	1138	1138	1185	1044	1274	866
26000	75	1262	957	1387	760	1496	551	1207	929	1328	734	1433	526	1147	897	1263	705	1363	500	1093	869	1198	677	1289	472
	80	1271	1107	1390	913	1496	702	1217	1078	1332	887	1434	677	1159	1047	1266	858	1365	650	1104	1017	1201	828	1291	622
	85	1287	1256	1392	1064	1497	852	1238	1219	1334	1036	1435	827	1182	1182	1270	1005	1366	800	1133	1133	1206	974	1291	771
	90	1339	1339	1400	1211	1500	1003	1292	1292	1343	1183	1436	978	1241	1241	1280	1152	1367	949	1188	1188	1215	1120	1292	919
30000	75	1302	1024	1422	799	1524	559	1245	994	1361	773	1458	535	1183	962	1294	744	1385	508	1124	931	1225	715	1309	480
	80	1316	1197	1424	974	1528	733	1260	1167	1364	946	1458	707	1200	1135	1297	916	1385	679	1139	1098	1227	884	1308	651
	85	1344	1344	1429	1142	1531	906	1295	1295	1370	1113	1458	878	1241	1241	1303	1082	1384	850	1186	1186	1235	1049	1308	821
	90	1405	1405	1440	1311	1532	1078	1354	1354	1381	1282	1460	1047	1298	1298	1312	1253	1385	1016	1238	1238	1247	1205	1307	983
35000	75	1342	1102	1454	845	1555	572	1283	1072	1391	819	1479	544	1219	1039	1321	790	1405	518	1156	1006	1248	760	1327	491
	80	1357	1306	1456	1043	1559	772	1302	1265	1393	1014	1482	744	1237	1237	1324	982	1402	715	1180	1180	1252	949	1323	686
	85	1408	1408	1463	1235	1561	972	1356	1356	1402	1206	1484	942	1297	1297	1333	1174	1403	912	1236	1236	1261	1140	1321	878
	90	1464	1464	1473	1424	1565	1163	1410	1410	1416	1382	1488	1131	1348	1348	1347	1347	1405	1097	1280	1280	1280	1280	1322	1062
40000	75	1373	1177	1477	890	1579	583	1313	1146	1412	862	1498	555	1247	1112	1340	832	1420	528	1181	1079	1265	800	1340	501
	80	1394	1394	1479	1107	1582	810	1340	1340	1416	1078	1502	781	1280	1280	1345	1052	1417	751	1219	1219	1270	1012	1336	723
	85	1455	1455	1487	1324	1583	1033	1399	1399	1425	1295	1503	1001	1337	1337	1354	1263	1418	966	1270	1270	1280	1228	1332	931
	90	1511	1511	1510	1510	1591	1247	1448	1448	1447	1447	1509	1213	1380	1380	1379	1379	1423	1178	1306	1306	1306	1306	1335	1141
45000	75	1399	1249	1494	932	1597	594	1337	1218	1428	902	1514	566	1270	1183	1355	870	1431	538	1199	1147	1279	836	1350	511
	80	1432	1432	1497	1168	1600	846	1376	1376	1432	1139	1517	819	1314	1314	1360	1107	1430	787	1248	1248	1284	1072	1343	754
	85	1489	1489	1511	1413	1602	1089	1430	1430	1442	1381	1518	1056	1364	1364	1370	1335	1431	1020	1292	1292	1295	1274	1342	984
	90	1552	1552	1551	1551	1613	1329	1483	1483	1482	1482	1528	1294	1407	1407	1406	1406	1439	1257	1327	1327	1327	1327	1348	1219
50000	75	1412	1337	1508	967	1611	605	1353	1293	1441	938	1527	577	1287	1244	1367	905	1440	548	1214	1214	1290	870	1359	521
	80	1462	1462	1512	1229	1613	883	1404	1404	1445	1199	1529	852	1339	1339	1371	1166	1440	820	1270	1270	1294	1130	1352	784
	85	1522	1522	1534	1498	1618	1144	1455	1455	1460	1441	1532	1110	1384	1384	1386	1382	1442	1073	1309	1309	1309	1309	1350	1036
	90	1587	1587	1587	1587	1630	1408	1513	1513	1512	1512	1543	1373	1432	1432	1432	1432	1447	1350	1348	1348	1347	1347	1356	1286
55000	75	1433	1384	1518	1002	1623	615	1366	1366	1451	972	1537	587	1301	1301	1376	939	1448	558	1235	1235	1298	904	1366	531
	80	1485	1485	1528	1290	1625	918	1426	1426	1454	1257	1538	883	1358	1358	1380	1223	1449	848	1287	1287	1302	1187	1358	811
	85	1550	1550	1554	1547	1631	1198	1479	1479	1480	1480	1543	1163	1402	1402	1401	1401	1451	1125	1322	1322	1322	1322	1358	1087
	90	1616	1616	1615	1615	1645	1486	1537	1537	1537	1537	1551	1461	1452	1452	1452	1452	1460	1397	1363	1363	1362	1362	1362	1362
58000	75	1437	1437	1523	1022	1629	622	1378	1378	1456	992	1543	593	1313	1313	1381	959	1453	564	1245	1245	1302	923	1370	537
	80	1497	1497	1536	1326	1632	935	1436	1436	1460	1291	1543	900	1368	1368	1386	1283	1453	864	1295	1295	1303	1227	1362	827
	85	1564	1564	1567	1567	1638	1230	1491	1491	1491	1491	1549	1194	1412	1412	1412	1412	1456	1156	1330	1330	1329	1329	1362	1117
	90	1630	1630	1630	1630	1647	1550	1550	1550	1549	1549	1559	1490	1462	1462	1461	1461	1461	1461	1461	1461	1461	1461	1369	1369

Table 38. Gross cooling capacities – 150 tons – standard evaporator coil, 50Hz

CFM	Ent DB (°F)	Ambient Temperature (°F)																							
		85						95						105						115					
		Entering Wet Bulb (°F)						Entering Wet Bulb (°F)						Entering Wet Bulb (°F)						Entering Wet Bulb (°F)					
		61	67	73	79	85	91	61	67	73	79	85	91	61	67	73	79	85	91	61	67	73	79	85	91
23000	75	1288	941	1419	761	1546	574	1237	914	1365	736	1493	554	1179	884	1305	709	1430	528	1126	857	1245	682	1365	504
	80	1289	1080	1422	901	1547	712	1237	1051	1370	876	1494	690	1182	1021	1309	848	1433	665	1128	991	1249	821	1368	639
	85	1300	1221	1425	1040	1547	848	1248	1189	1373	1015	1496	827	1194	1158	1314	988	1436	802	1142	1130	1253	960	1370	776
	90	1333	1333	1426	1178	1549	985	1290	1290	1374	1151	1497	964	1245	1244	1318	1121	1438	939	1197	1197	1257	1092	1373	912
26000	75	1328	999	1457	794	1580	583	1276	972	1402	769	1525	561	1211	940	1334	751	1463	538	1157	913	1277	714	1393	512
	80	1332	1153	1461	951	1581	737	1281	1131	1406	926	1527	716	1221	1092	1346	899	1465	692	1165	1072	1282	870	1397	666
	85	1346	1309	1463	1107	1581	891	1296	1282	1408	1081	1528	870	1243	1243	1348	1052	1467	845	1194	1194	1285	1022	1400	819
	90	1399	1399	1467	1258	1582	1044	1354	1354	1415	1232	1530	1023	1306	1306	1357	1202	1469	999	1255	1255	1293	1173	1402	972
30000	75	1368	1069	1497	835	1616	594	1312	1039	1441	811	1559	573	1253	1014	1378	784	1495	549	1192	985	1311	756	1424	523
	80	1379	1255	1499	1014	1616	770	1325	1216	1444	990	1561	749	1267	1188	1382	963	1498	725	1209	1154	1316	934	1428	699
	85	1406	1405	1503	1190	1617	946	1361	1360	1448	1162	1561	924	1310	1308	1387	1134	1499	901	1257	1257	1321	1104	1429	874
	90	1470	1469	1510	1363	1620	1123	1424	1424	1457	1337	1563	1102	1373	1373	1397	1309	1501	1076	1318	1318	1332	1277	1432	1047
35000	75	1412	1155	1534	884	1651	607	1354	1127	1477	860	1593	586	1291	1090	1413	834	1526	563	1228	1060	1343	805	1455	537
	80	1426	1356	1536	1092	1652	811	1372	1328	1479	1064	1592	789	1335	1302	1415	1034	1528	766	1251	1251	1346	1004	1456	740
	85	1476	1475	1538	1286	1654	1016	1429	1428	1486	1262	1591	992	1375	1375	1423	1233	1528	969	1318	1318	1356	1202	1457	943
	90	1538	1538	1552	1490	1656	1217	1492	1491	1499	1465	1593	1190	1438	1438	1438	1437	1530	1164	1380	1380	1380	1379	1459	1134
40000	75	1443	1231	1562	932	1678	619	1384	1198	1504	908	1619	599	1320	1170	1435	879	1553	575	1257	1133	1366	853	1480	549
	80	1464	1462	1564	1159	1679	852	1414	1413	1505	1132	1615	829	1359	1356	1439	1103	1551	806	1300	1300	1370	1071	1478	781
	85	1528	1527	1570	1384	1680	1084	1481	1481	1515	1358	1615	1057	1426	1426	1452	1330	1551	1031	1366	1366	1384	1299	1478	1001
	90	1592	1591	1591	1591	1684	1305	1542	1542	1541	1538	1616	1276	1488	1488	1487	1485	1552	1250	1427	1427	1426	1426	1480	1221
45000	75	1471	1310	1584	978	1700	632	1412	1281	1523	949	1640	612	1347	1244	1456	919	1571	588	1281	1210	1385	889	1495	563
	80	1507	1507	1585	1226	1701	892	1457	1455	1528	1201	1634	868	1400	1399	1463	1176	1571	849	1338	1338	1391	1140	1497	817
	85	1571	1570	1595	1479	1702	1143	1523	1523	1539	1454	1631	1115	1466	1466	1478	1425	1568	1089	1404	1404	1409	1394	1494	1059
	90	1640	1640	1639	1638	1707	1392	1583	1583	1582	1580	1637	1363	1527	1527	1526	1524	1569	1335	1463	1463	1463	1463	1497	1306
50000	75	1493	1381	1601	1018	1720	645	1436	1352	1540	988	1659	625	1384	1322	1473	958	1588	601	1347	1292	1401	927	1512	576
	80	1540	1539	1599	1302	1719	931	1491	1490	1546	1266	1654	909	1433	1432	1480	1237	1586	881	1370	1370	1410	1205	1511	848
	85	1608	1608	1621	1575	1719	1201	1554	1554	1562	1548	1647	1174	1499	1499	1501	1501	1581	1146	1435	1435	1434	1434	1507	1117
	90	1679	1679	1677	1677	1725	1478	1620	1620	1616	1615	1655	1449	1557	1557	1557	1556	1585	1421	1493	1493	1492	1492	1512	1391
55000	75	1559	1463	1615	1055	1732	653	1457	1425	1555	1026	1674	637	1389	1382	1487	996	1602	614	1325	1325	1414	964	1525	589
	80	1571	1571	1616	1366	1734	967	1520	1519	1559	1331	1666	940	1461	1461	1494	1301	1599	911	1396	1396	1421	1267	1525	879
	85	1642	1642	1646	1646	1734	1260	1582	1582	1585	1585	1661	1232	1526	1526	1525	1525	1591	1203	1460	1460	1459	1459	1518	1173
	90	1711	1711	1710	1710	1743	1563	1651	1651	1647	1647	1673	1535	1584	1584	1584	1584	1599	1505	1517	1517	1516	1516	1545	1470
58000	75	1526	1498	1622	1077	1745	665	1463	1455	1562	1049	1682	644	1403	1397	1494	1018	1609	621	1338	1338	1420	986	1532	596
	80	1585	1585	1629	1397	1742	986	1534	1534	1568	1369	1673	958	1475	1475	1502	1339	1606	929	1409	1409	1429	1305	1531	896
	85	1657	1657	1661	1661	1742	1295	1599	1599	1599	1599	1669	1266	1540	1540	1540	1540	1597	1237	1474	1474	1474	1474	1523	1207
	90	1727	1727	1727	1727	1753	1614	1666	1666	1664	1664	1681	1585	1599	1599	1599	1597	1597	1640	1553	1530	1530	1528	1528	1526



Performance Data

Table 39. Gross cooling capacities – 150 tons eFlex™ variable speed – standard evaporator coil, 50Hz

CFM	Ent DB (°F)	Ambient Temperature (°F)																							
		85						95						105						115					
		Entering Wet Bulb (°F)			Entering Wet Bulb (°F)			Entering Wet Bulb (°F)			Entering Wet Bulb (°F)			Entering Wet Bulb (°F)			Entering Wet Bulb (°F)			Entering Wet Bulb (°F)					
		61	67	73	61	67	73	61	67	73	61	67	73	61	67	73	61	67	73						
23000	75	1349	975	1486	793	1608	598	1292	945	1426	765	1548	573	1235	915	1363	736	1480	546	1190	892	1308	710	1414	520
	80	1353	1119	1489	934	1609	737	1294	1086	1430	906	1549	712	1238	1054	1367	876	1482	685	1193	1030	1311	851	1415	658
	85	1359	1257	1492	1075	1610	876	1304	1225	1433	1047	1550	851	1248	1194	1370	1017	1484	823	1204	1169	1314	990	1417	796
	90	1386	1386	1494	1215	1610	1014	1340	1340	1435	1186	1551	989	1292	1292	1373	1154	1485	961	1251	1251	1316	1126	1418	933
26000	75	1393	1034	1526	826	1638	604	1333	1003	1465	798	1577	580	1273	973	1399	768	1508	554	1223	948	1339	742	1439	527
	80	1397	1191	1529	984	1638	760	1338	1159	1468	956	1577	736	1279	1127	1403	926	1509	709	1230	1100	1342	899	1439	682
	85	1410	1350	1532	1142	1641	917	1353	1318	1472	1114	1578	891	1296	1286	1404	1083	1509	863	1250	1250	1344	1054	1439	836
	90	1457	1457	1535	1297	1644	1073	1408	1408	1476	1267	1578	1045	1355	1355	1411	1235	1509	1018	1308	1308	1350	1205	1439	990
30000	75	1438	1107	1566	866	1673	614	1374	1074	1503	839	1605	589	1311	1041	1434	809	1535	563	1259	1014	1371	782	1464	537
	80	1447	1285	1568	1047	1676	794	1387	1253	1506	1020	1604	766	1324	1219	1438	990	1533	739	1271	1191	1373	962	1461	712
	85	1470	1458	1570	1226	1679	973	1416	1416	1509	1197	1603	943	1361	1361	1441	1165	1531	916	1311	1311	1376	1134	1459	888
	90	1531	1531	1576	1400	1681	1151	1479	1479	1516	1371	1605	1121	1423	1423	1450	1339	1531	1092	1367	1367	1385	1307	1460	1063
35000	75	1482	1190	1600	914	1708	627	1418	1157	1537	887	1631	599	1351	1123	1466	857	1559	574	1295	1094	1398	829	1487	548
	80	1496	1398	1601	1123	1710	834	1435	1366	1538	1095	1631	805	1370	1332	1469	1066	1553	776	1313	1302	1400	1031	1480	750
	85	1539	1539	1605	1323	1711	1040	1485	1485	1543	1294	1632	1011	1426	1426	1474	1262	1550	980	1369	1369	1405	1230	1480	956
	90	1596	1596	1613	1525	1713	1245	1543	1543	1553	1497	1634	1212	1482	1482	1486	1465	1551	1178	1419	1419	1419	1419	1473	1145
40000	75	1516	1270	1624	960	1734	639	1452	1237	1560	933	1652	610	1383	1202	1488	904	1578	585	1322	1171	1418	877	1505	560
	80	1534	1504	1626	1191	1734	873	1475	1463	1562	1162	1652	844	1412	1412	1491	1130	1569	814	1354	1354	1420	1098	1492	787
	85	1590	1590	1631	1418	1736	1109	1535	1535	1567	1389	1653	1077	1473	1473	1497	1357	1568	1043	1410	1410	1426	1324	1489	1010
	90	1650	1650	1653	1637	1740	1333	1584	1584	1583	1583	1655	1298	1519	1519	1518	1518	1569	1263	1451	1451	1451	1451	1485	1228
45000	75	1543	1347	1643	1006	1754	651	1478	1314	1579	980	1670	622	1408	1279	1505	947	1593	596	1345	1247	1435	915	1520	571
	80	1571	1571	1644	1257	1754	912	1514	1514	1580	1228	1669	882	1450	1450	1508	1195	1582	852	1388	1388	1436	1162	1513	832
	85	1629	1629	1658	1515	1756	1170	1570	1570	1585	1481	1669	1135	1505	1505	1515	1449	1582	1100	1438	1438	1443	1415	1498	1066
	90	1694	1694	1694	1694	1761	1420	1623	1623	1623	1623	1673	1384	1547	1547	1547	1547	1547	1583	1347	1473	1473	1472	1472	1496
50000	75	1565	1422	1660	1047	1771	662	1500	1389	1593	1018	1684	633	1430	1354	1519	985	1606	607	1364	1320	1447	952	1532	583
	80	1603	1603	1664	1324	1770	951	1545	1545	1593	1292	1682	922	1480	1480	1520	1259	1599	891	1415	1415	1447	1226	1521	860
	85	1667	1667	1681	1610	1772	1229	1597	1597	1604	1574	1682	1193	1528	1528	1529	1529	1592	1156	1458	1458	1458	1458	1505	1121
	90	1731	1731	1730	1730	1780	1507	1654	1654	1653	1653	1688	1469	1573	1573	1572	1572	1596	1431	1492	1492	1492	1492	1505	1394
55000	75	1583	1495	1671	1084	1785	674	1519	1463	1605	1055	1697	645	1448	1426	1531	1021	1618	619	1379	1379	1458	988	1544	595
	80	1628	1628	1680	1390	1785	990	1569	1569	1603	1355	1696	956	1503	1503	1530	1322	1608	920	1435	1435	1456	1288	1528	887
	85	1697	1697	1701	1692	1785	1287	1624	1624	1625	1625	1694	1250	1546	1546	1546	1546	1601	1212	1472	1472	1472	1472	1512	1175
	90	1763	1763	1762	1762	1797	1592	1680	1680	1680	1680	1700	1553	1595	1595	1594	1594	1606	1514	1509	1509	1509	1509	1514	1475
58000	75	1593	1538	1678	1107	1792	680	1527	1501	1611	1076	1704	652	1456	1456	1536	1043	1625	626	1391	1391	1463	1009	1551	602
	80	1645	1645	1689	1429	1791	1010	1581	1581	1609	1393	1702	974	1514	1514	1536	1359	1612	937	1445	1445	1461	1325	1531	903
	85	1712	1712	1713	1713	1792	1321	1638	1638	1637	1637	1700	1284	1558	1558	1557	1557	1606	1246	1481	1481	1481	1481	1515	1208
	90	1780	1780	1779	1779	1805	1643	1693	1693	1692	1692	1708	1603	1605	1605	1605	1605	1605	1605	1605	1518	1518	1517	1517	1517

Table 40. Gross cooling capacities – 90 tons – high capacity evaporator coil, 50Hz

CFM	Ent DB (°F)	Ambient Temperature (°F)																										
		85						95						105						115								
		Entering Wet Bulb (°F)			Entering Wet Bulb (°F)			Entering Wet Bulb (°F)			Entering Wet Bulb (°F)			Entering Wet Bulb (°F)			Entering Wet Bulb (°F)			Entering Wet Bulb (°F)								
		61	67	73	61	67	73	61	67	73	61	67	73	61	67	73	61	67	73									
16000	75	834	617	916	495	589	1000	462	804	691	884	573	964	448	770	673	847	556	925	432	922	339	735	565	809	446	882	323
	80	837	709	919	589	1000	462	804	691	884	573	964	448	770	673	847	556	925	432	922	339	735	565	809	446	882	323	
	85	845	803	920	684	1001	555	812	785	885	667	966	541	780	767	849	649	928	525	749	549	813	633	888	510	888	510	
20000	75	871	871	924	774	1003	648	843	843	890	757	968	634	814	814	854	739	929	618	786	786	818	721	890	602	890	602	
	80	877	685	958	536	1037	381	841	666	921	520	999	367	804	647	881	503	957	351	771	629	842	487	916	336	916	336	
	85	884	799	960	653	1039	496	849	781	924	637	1002	482	813	761	883	617	961	466	779	743	844	599	920	451	920	451	
25000	75	902	902	963	764	1040	611	872	872	928	747	1003	597	841	841	889	728	963	581	809	809	849	710	922	566	922	566	
	80	943	943	969	877	1041	724	914	914	934	860	1005	709	881	881	896	841	964	692	848	848	857	822	924	675	924	675	
	85	1007	1007	1010	1000	1072	810	976	976	976	976	1035	794	941	941	941	941	994	777	906	906	906	905	952	760	952	760	
30000	75	942	837	1014	626	1094	407	904	818	975	608	1053	393	864	797	932	589	1008	378	825	777	889	570	965	364	965	364	
	80	967	967	1018	787	1092	575	933	933	980	769	1053	563	897	897	938	750	1010	546	860	860	896	731	967	528	967	528	
	85	1011	1011	1025	952	1092	733	978	978	989	934	1053	717	942	942	942	942	962	733	924	924	924	923	976	715	976	715	
33000	75	1052	1052	1052	1052	1095	893	1019	1019	1019	1019	1054	877	983	983	1003	1003	1003	983	983	983	983	983	983	983	983	983	983
	80	955	880	1025	649	1106	415	917	861	985	631	1063	400	877	840	942	611	1018	386	837	819	899	592	975	371	975	371	
	85	988	988	1029	825	1105	598	954	954	991	807	1064	581	917	917	948	788	1020	564	879	879	906	768	976	546	976	546	
36000	75	1032	1032	1039	1006	1102	767	999	999	1002	989	1062	751	961	961	961	961	962	733	924	924	924	923	976	715	976	715	
	80	1075	1075	1074	1074	1107	944	1039	1039	1039	1039	1064	926	1003	1003	1003	1003	1003	1003	983	983	983	983	983	983	983	983	983
	85	967	923	1035	671	1115	422	929	903	994	653	1072	408	889	882	950	633	1027	393	848	848	908	613	984	379	984	379	
40000	75	1006	1006	1039	862	1114	616	972	972	1000	845	1072	599	934	934	958	825	1029	581	895	895	915	805	984	563	984	563	
	80	1050	1050	1051	1051	1111	800	1016	1016	1016	1016	1070	783	978	978	978	978	978	766	940	940	940	940	940	940	940	940	940
	85	1094	1094	1094	1094	1118	993	1056	1056	1056	1056	1073	975	1019	1019	1019	1019	1019	1019	957	980	980	979	979	988	938	988	938
40000	75	979	979	1045	700	1127	432	943	943	1004	681	1082	417	905	905	960	660	1036	403	865	865	917	640	993	389	993	389	
	80	1026	1026	1049	912	1123	639	991	991	1011	894	1082	622	953	953	968	874	1038	604	913	913	926	854	993	585	993	585	
	85	1071	1071	1070	1070	1120	844	1036	1036	1035	1035	1078	827	998	998	997	997	997	1036	809	958	958	958	958	991	790	991	790
90	1118	1118	1118	1118	1131	1059	1076	1076	1076	1076	1076	1084	1038	1037	1037	1037	1037	1037	1041	1020	996	996	996	996	996	996	996	996



Performance Data

Table 41. Gross cooling capacities – 90 tons eFlex™ variable speed – high capacity evaporator coil, 50Hz

CFM	Ent DB (°F)	Ambient Temperature (°F)																																																																																																						
		85						95						105						115																																																																																				
		Entering Wet Bulb (°F)			73			61			67			73			61			67			73			61			67			73																																																																								
		CAP	SHC	SHC	CAP	SHC	SHC	CAP	SHC	SHC	CAP	SHC	SHC	CAP	SHC	SHC	CAP	SHC	SHC	CAP	SHC	SHC	CAP	SHC	SHC	CAP	SHC	SHC	CAP	SHC	SHC																																																																									
16000	75	883	643	973	521	1054	390	845	623	929	500	1008	371	815	607	886	480	958	351	805	602	850	463	909	332	80	887	737	976	616	1055	484	848	716	932	595	1010	465	818	699	888	574	960	445	805	691	851	557	911	425	85	894	832	978	711	1056	578	856	810	934	690	1012	559	823	791	890	669	962	538	806	782	852	650	912	518	90	914	914	981	804	1057	671	881	881	938	782	1013	652	849	849	894	759	963	631	824	824	854	739	913	611				
	75	932	714	1018	562	1086	398	889	691	971	541	1039	380	850	670	922	520	987	361	825	657	877	500	934	342	80	940	830	1020	679	1087	514	897	807	974	659	1040	495	856	785	924	636	987	475	827	769	878	615	934	455	85	955	941	1023	793	1088	629	915	915	978	771	1039	610	877	877	928	747	987	590	844	844	882	725	933	569	90	995	995	1028	906	1089	744	957	957	984	884	1040	724	916	916	935	860	988	702	876	876	888	837	933	679				
	75	975	794	1051	608	1114	409	929	770	1003	588	1062	390	882	746	950	566	1008	371	846	727	900	546	954	352	80	987	938	1053	749	1113	551	942	914	1005	727	1061	532	896	884	953	702	1005	512	856	856	903	679	948	491	85	1019	1019	1057	886	1115	694	979	979	1010	865	1061	673	934	934	959	840	1005	649	891	891	908	816	947	625	90	1057	1057	1063	1027	1119	829	1016	1016	1019	998	1062	806	969	969	969	969	1005	782	921	921	921	921	944	756				
	30000	75	1004	869	1072	652	1132	420	957	845	1022	620	1079	401	907	819	968	605	1022	382	863	797	917	582	967	363	80	1022	1022	1073	812	1134	590	980	980	1025	790	1077	569	934	934	972	765	1020	550	889	889	919	741	962	526	85	1061	1061	1076	975	1136	752	1019	1019	1029	954	1077	727	971	971	977	929	1017	702	921	921	924	904	955	677	90	1096	1096	1095	1095	1142	913	1048	1048	1048	1048	1080	888	996	996	996	996	1016	861	941	941	940	940	952	834			
75		1018	912	1081	674	1142	426	970	888	1031	652	1087	408	919	862	976	627	1029	388	873	838	924	603	973	370	80	1043	1043	1081	848	1143	612	1000	1000	1033	827	1085	591	951	951	980	802	1026	566	904	904	926	777	966	541	85	1078	1078	1087	1029	1146	785	1033	1033	1038	1005	1084	760	984	984	985	978	1022	734	932	932	931	931	958	707	90	1118	1118	1118	1118	1153	963	1066	1066	1065	1065	1089	936	1009	1009	1009	1009	1022	909	950	950	950	949	954	880				
75		1029	955	1088	695	1150	433	981	930	1038	672	1093	414	929	903	983	647	1035	395	880	880	930	623	979	377	80	1059	1059	1089	885	1150	631	1015	1015	1039	863	1091	607	966	966	985	838	1031	582	917	917	931	812	970	556	85	1093	1093	1098	1078	1155	818	1046	1046	1047	1043	1091	792	994	994	994	994	1025	765	939	939	939	939	961	738	90	1138	1138	1138	1138	1162	1012	1081	1081	1080	1080	1096	984	1020	1020	1020	1020	1020	1020	955	955	955	955	955	957	925			
40000		75	1041	1009	1096	722	1159	442	994	977	1046	700	1101	423	942	942	991	674	1042	404	895	895	937	649	986	386	80	1075	1075	1097	934	1159	654	1030	1030	1046	910	1098	629	980	980	992	884	1036	603	929	929	936	858	973	576	85	1115	1115	1115	1115	1164	862	1061	1061	1061	1061	1098	835	1007	1006	1006	1006	1006	1006	1031	806	948	948	948	948	963	777	90	1159	1159	1159	1159	1172	1076	1098	1098	1098	1098	1105	1047	1032	1032	1031	1031	1031	1031	1034	1014	960	960	960	960	959

Table 42. Gross cooling capacities – 105 tons – high capacity evaporator coil, 50Hz

CFM	Ent DB (°F)	Ambient Temperature (°F)																										
		85						95						105						115								
		61			67			73			61			67			73			61			67			73		
		CAP	SHC	SHC	CAP	SHC	SHC	CAP	SHC	SHC	CAP	SHC	SHC	CAP	SHC	SHC	CAP	SHC	SHC	CAP	SHC	SHC	CAP	SHC	SHC			
19000	75	965	721	1055	573	1146	423	926	701	1014	555	1103	407	884	680	969	535	1057	390	845	661	928	516	1012	373			
	80	968	830	1058	685	1148	534	931	810	1018	667	1106	517	890	787	985	656	1061	500	849	766	935	633	1016	482			
	85	987	945	1060	796	1149	644	938	918	1020	776	1108	627	910	902	976	755	1064	609	866	866	935	735	1018	591			
	90	1010	1010	1065	903	1151	754	978	978	1025	884	1110	737	945	944	982	863	1065	721	908	908	940	842	1019	701			
23000	75	1004	786	1094	614	1183	436	961	766	1051	595	1139	419	920	744	1005	576	1092	402	875	722	962	558	1045	384			
	80	1011	917	1095	748	1184	567	971	895	1054	729	1142	551	928	873	1009	710	1095	533	887	851	965	691	1046	515			
	85	1033	1033	1100	875	1185	699	999	999	1059	855	1143	683	961	961	1014	834	1096	665	925	925	969	813	1048	647			
	90	1080	1079	1107	1005	1187	829	1045	1044	1066	985	1145	811	1007	1007	1021	964	1099	791	970	970	977	942	1048	770			
28000	75	1041	864	1126	664	1216	449	997	844	1081	644	1171	433	952	818	1034	623	1124	415	908	794	989	602	1072	398			
	80	1053	1023	1130	816	1216	607	1011	1002	1086	798	1172	591	971	971	1039	774	1124	574	932	932	992	753	1074	559			
	85	1096	1096	1136	970	1216	764	1059	1059	1093	950	1173	745	1019	1019	1048	929	1125	726	980	980	1001	907	1074	705			
	90	1143	1142	1147	1128	1217	914	1106	1106	1106	1105	1174	896	1067	1067	1067	1066	1126	875	1025	1025	1025	1024	1074	854			
33000	75	1068	938	1151	703	1240	462	1024	915	1105	682	1194	446	976	890	1058	661	1144	429	932	868	1011	639	1093	412			
	80	1093	1092	1154	881	1234	643	1055	1054	1109	861	1195	633	1013	1013	1062	839	1146	610	972	972	1014	817	1094	589			
	85	1143	1142	1162	1063	1237	821	1104	1104	1119	1043	1194	803	1063	1063	1074	1022	1145	782	1021	1021	1026	999	1093	760			
	90	1188	1188	1188	1188	1241	998	1152	1152	1151	1151	1195	979	1110	1110	1109	1109	1146	959	1065	1065	1065	1064	1094	937			
38000	75	1088	1009	1169	740	1260	474	1045	987	1123	719	1209	455	998	962	1075	698	1162	440	954	939	1027	675	1110	441			
	80	1129	1128	1173	945	1259	682	1089	1089	1128	924	1212	662	1047	1047	1080	902	1162	639	1004	1004	1031	879	1109	617			
	85	1178	1178	1184	1153	1255	878	1139	1139	1142	1134	1209	858	1097	1097	1097	1097	1160	837	1052	1052	1050	1050	1106	815			
	90	1226	1226	1226	1226	1259	1081	1186	1186	1184	1184	1210	1060	1142	1142	1141	1141	1161	1040	1095	1095	1094	1094	1110	1019			
43000	75	1135	1082	1184	776	1276	487	1065	1057	1137	755	1226	471	1019	1019	1088	733	1173	450	976	976	1040	709	1121	434			
	80	1157	1156	1188	1007	1273	712	1116	1116	1143	986	1225	691	1073	1073	1094	964	1175	668	1028	1028	1044	940	1121	645			
	85	1206	1206	1206	1206	1269	933	1167	1167	1166	1166	1221	912	1123	1123	1122	1122	1171	891	1076	1076	1081	1081	1117	869			
	90	1257	1257	1256	1256	1276	1163	1213	1213	1211	1211	1224	1141	1167	1167	1166	1166	1175	1121	1119	1119	1118	1118	1122	1098			
45000	75	1113	1111	1189	790	1277	508	1072	1072	1142	769	1231	476	1028	1028	1093	747	1180	459	984	984	1044	723	1126	440			
	80	1167	1166	1193	1032	1277	723	1126	1126	1148	1011	1230	702	1082	1082	1100	988	1180	679	1037	1037	1048	963	1126	656			
	85	1217	1217	1215	1215	1273	954	1176	1176	1175	1175	1225	934	1133	1133	1136	1136	1175	913	1085	1085	1095	1095	1121	890			
	90	1268	1268	1268	1268	1282	1196	1224	1224	1221	1221	1230	1173	1178	1178	1175	1175	1180	1151	1127	1127	1126	1126	1125	1123			

Table 43. Gross cooling capacities – 105 tons eFlex™ variable speed – high capacity evaporator coil, 50Hz

CFM	Ent DB (°F)	Ambient Temperature (°F)																							
		85						95						105						115					
		61		67		73		61		67		73		61		67		73		61		67		73	
CAP	SHC	CAP	SHC	CAP	SHC	CAP	SHC	CAP	SHC	CAP	SHC	CAP	SHC	CAP	SHC	CAP	SHC	CAP	SHC	CAP	SHC	CAP	SHC		
19000	75	1009	744	1103	595	1187	438	962	719	1053	572	1136	418	923	698	1003	550	1080	397	903	688	962	531	1027	376
	80	1013	855	1106	708	1188	549	968	830	1056	685	1137	529	927	808	1006	662	1082	507	903	794	963	643	1028	486
	85	1022	967	1108	820	1188	660	978	942	1059	796	1138	640	939	910	1009	772	1083	617	911	887	965	751	1028	596
	90	1051	1051	1112	929	1188	770	1012	1012	1063	905	1139	750	972	972	1013	880	1084	728	939	939	969	858	1029	704
23000	75	1052	812	1142	635	1217	447	1002	786	1090	612	1164	427	956	761	1036	589	1107	406	926	745	989	569	1050	385
	80	1060	945	1143	770	1217	579	1012	919	1092	746	1163	559	964	893	1038	721	1106	537	930	875	990	699	1048	516
	85	1079	1066	1147	900	1218	712	1034	1034	1096	875	1162	691	991	991	1043	849	1106	670	954	954	993	826	1047	646
	90	1121	1121	1152	1029	1218	843	1078	1078	1102	1005	1163	821	1033	1033	1049	979	1104	795	990	990	999	949	1044	770
28000	75	1091	890	1173	681	1243	458	1039	863	1119	659	1188	438	988	837	1062	634	1129	417	948	816	1011	612	1070	397
	80	1103	1052	1174	838	1243	617	1053	1019	1122	813	1184	596	1005	981	1066	787	1123	574	963	948	1013	763	1066	554
	85	1139	1139	1178	992	1245	776	1093	1093	1127	968	1184	753	1045	1045	1071	942	1122	727	999	999	999	916	1059	700
	90	1178	1178	1185	1142	1249	929	1132	1132	1135	1105	1185	902	1081	1081	1081	1065	1120	875	1028	1028	1028	1028	1054	847
33000	75	1119	965	1194	724	1262	469	1066	937	1139	700	1205	449	1013	910	1081	674	1145	428	967	887	1028	649	1085	408
	80	1139	1130	1195	901	1264	656	1090	1090	1142	877	1200	633	1040	1040	1084	850	1138	609	994	994	1028	824	1077	585
	85	1180	1180	1199	1082	1266	834	1132	1132	1146	1057	1199	807	1080	1080	1089	1030	1133	779	1027	1027	1031	987	1066	751
	90	1220	1220	1220	1220	1271	1013	1166	1166	1166	1166	1202	984	1109	1109	1109	1109	1132	955	1048	1048	1047	1047	1061	925
38000	75	1140	1037	1209	761	1277	480	1087	1009	1154	736	1219	460	1031	980	1095	709	1158	440	984	944	1039	683	1097	420
	80	1170	1170	1209	963	1279	691	1121	1121	1155	938	1214	665	1069	1069	1097	911	1149	639	1018	1018	1038	884	1087	612
	85	1210	1210	1217	1171	1282	890	1158	1158	1162	1126	1212	861	1101	1101	1103	1083	1141	831	1043	1043	1043	1038	1071	802
	90	1255	1255	1255	1255	1288	1095	1194	1194	1194	1194	1215	1065	1129	1129	1129	1129	1129	1141	1033	1061	1061	1061	1061	1065
43000	75	1156	1108	1221	796	1290	491	1104	1068	1166	770	1230	472	1049	1027	1106	742	1169	452	1000	988	1048	715	1108	433
	80	1193	1193	1221	1024	1291	721	1143	1143	1164	998	1222	692	1089	1089	1106	970	1157	664	1034	1034	1046	941	1092	636
	85	1237	1237	1238	1227	1294	945	1178	1178	1178	1178	1221	914	1118	1118	1117	1117	1148	883	1055	1055	1054	1054	1075	851
	90	1283	1283	1283	1283	1301	1176	1216	1216	1215	1215	1226	1144	1144	1144	1144	1144	1144	1148	1095	1069	1069	1069	1070	1038
45000	75	1163	1126	1225	809	1294	496	1111	1087	1169	784	1235	477	1056	1045	1109	756	1173	457	1005	1005	1051	728	1112	438
	80	1201	1201	1225	1048	1295	732	1150	1150	1167	1021	1225	702	1095	1095	1108	993	1159	674	1040	1040	1048	964	1094	645
	85	1246	1246	1247	1247	1299	966	1185	1185	1185	1185	1224	935	1123	1123	1123	1123	1150	904	1059	1059	1059	1059	1076	871
	90	1293	1293	1292	1292	1306	1208	1223	1223	1223	1223	1229	1168	1149	1149	1148	1148	1151	1112	1072	1072	1071	1071	1071	1055

Table 44. Gross cooling capacities – 120 tons – high capacity evaporator coil, 50Hz

CFM	Ent DB (°F)	Ambient Temperature (°F)																										
		85						95						105						115								
		61			67			73			61			67			73			61			67			73		
		CAP	SHC	SHC	CAP	SHC	SHC	CAP	SHC	SHC	CAP	SHC	SHC	CAP	SHC	SHC	CAP	SHC	SHC	CAP	SHC	SHC	CAP	SHC	SHC			
21000	75	1084	803	1196	645	1306	482	1036	782	1153	626	1263	465	990	756	1104	604	1215	447	943	732	1054	582	1161	426			
	80	1086	927	1199	769	1307	604	1045	906	1157	749	1266	587	1009	886	1110	728	1218	568	952	853	1059	705	1166	547			
	85	1094	1047	1201	892	1308	725	1055	1025	1161	873	1268	708	1031	1009	1110	849	1221	689	968	968	1060	825	1169	668			
	90	1132	1132	1204	1012	1310	846	1098	1098	1163	991	1269	829	1061	1060	1116	967	1224	810	1021	1021	1067	944	1171	789			
26000	75	1137	890	1250	698	1356	498	1092	867	1206	678	1312	481	1043	841	1156	657	1261	463	994	816	1102	634	1204	443			
	80	1146	1040	1252	848	1355	645	1105	1020	1210	829	1314	629	1056	994	1160	808	1265	611	1010	966	1106	785	1210	591			
	85	1171	1170	1255	995	1357	794	1135	1134	1212	974	1314	777	1095	1094	1164	951	1267	759	1052	1052	1111	927	1213	738			
	90	1227	1226	1261	1141	1359	942	1191	1191	1220	1121	1315	925	1151	1151	1173	1098	1268	905	1106	1106	1123	1074	1213	883			
31000	75	1180	972	1287	746	1391	511	1134	948	1243	728	1347	495	1082	922	1190	706	1297	476	1031	894	1134	683	1239	456			
	80	1193	1148	1289	924	1392	686	1163	1130	1245	906	1346	670	1101	1100	1195	877	1297	652	1056	1056	1140	853	1241	631			
	85	1240	1240	1293	1092	1393	862	1203	1202	1250	1071	1345	844	1161	1160	1202	1049	1298	826	1115	1115	1148	1024	1242	803			
	90	1294	1294	1303	1266	1395	1032	1259	1259	1264	1246	1346	1012	1218	1218	1218	1216	1299	992	1172	1172	1172	1172	1244	970			
36000	75	1212	1049	1314	793	1418	524	1165	1024	1266	771	1373	509	1113	997	1213	748	1319	490	1059	970	1157	724	1259	470			
	80	1234	1234	1316	988	1419	726	1195	1194	1272	967	1370	709	1151	1150	1221	945	1321	692	1103	1103	1164	920	1263	672			
	85	1291	1291	1320	1185	1419	925	1254	1254	1279	1166	1369	905	1212	1211	1231	1144	1321	884	1164	1164	1177	1120	1264	861			
	90	1347	1347	1347	1347	1422	1118	1308	1308	1308	1307	1369	1096	1267	1267	1267	1265	1319	1076	1220	1220	1220	1220	1266	1054			
41000	75	1236	1122	1335	834	1441	538	1191	1099	1288	811	1395	522	1138	1073	1234	787	1338	503	1084	1045	1176	762	1277	483			
	80	1275	1275	1336	1053	1439	765	1236	1234	1292	1034	1393	751	1191	1190	1242	1012	1340	728	1142	1142	1185	987	1281	704			
	85	1332	1332	1346	1279	1440	983	1294	1294	1303	1259	1385	960	1251	1251	1256	1237	1337	940	1202	1202	1203	1203	1281	918			
	90	1393	1393	1392	1391	1443	1203	1348	1348	1346	1346	1389	1181	1305	1305	1305	1304	1338	1160	1257	1257	1256	1256	1283	1137			
46000	75	1258	1195	1352	872	1459	550	1233	1175	1305	848	1412	535	1154	1144	1250	824	1355	516	1105	1105	1192	799	1293	495			
	80	1308	1307	1353	1117	1456	800	1268	1267	1309	1098	1409	781	1223	1222	1258	1075	1356	757	1172	1172	1200	1048	1296	734			
	85	1368	1368	1371	1371	1455	1040	1325	1325	1326	1326	1400	1017	1282	1282	1281	1281	1350	996	1232	1232	1231	1231	1293	974			
	90	1428	1428	1428	1428	1463	1288	1383	1383	1380	1380	1406	1265	1334	1334	1334	1333	1353	1243	1286	1286	1285	1285	1296	1221			
51000	75	1273	1273	1365	908	1475	563	1231	1229	1318	885	1428	548	1183	1182	1264	860	1369	527	1131	1131	1204	834	1295	537			
	80	1334	1333	1371	1182	1470	830	1295	1294	1323	1161	1421	809	1249	1249	1272	1137	1368	786	1197	1197	1214	1110	1308	762			
	85	1394	1394	1396	1396	1469	1096	1350	1350	1353	1353	1413	1073	1308	1308	1310	1310	1359	1051	1257	1257	1265	1265	1304	1029			
	90	1461	1461	1460	1460	1480	1371	1410	1410	1408	1408	1421	1347	1360	1360	1359	1359	1366	1324	1309	1309	1308	1308	1306	1304			
54000	75	1288	1287	1372	930	1484	571	1245	1243	1325	906	1427	564	1197	1195	1270	881	1363	541	1144	1144	1211	855	1298	523			
	80	1349	1348	1377	1219	1478	848	1308	1308	1330	1197	1428	826	1262	1262	1279	1174	1374	803	1210	1210	1222	1147	1314	779			
	85	1413	1413	1414	1414	1476	1130	1365	1365	1370	1370	1420	1106	1321	1321	1327	1327	1366	1084	1270	1270	1281	1281	1309	1061			
	90	1477	1477	1477	1477	1490	1421	1423	1423	1423	1423	1423	1395	1373	1373	1373	1372	1372	1370	1369	1321	1321	1320	1320	1317	1317		

Table 45. Gross cooling capacities – 120 tons eFlex™ variable speed – high capacity evaporator coil, 50Hz

CFM	Ent DB (°F)	Ambient Temperature (°F)																							
		85						95						105						115					
		61		67		73		61		67		73		61		67		73		61		67		73	
CAP	SHC	CAP	SHC	CAP	SHC	CAP	SHC	CAP	SHC	CAP	SHC	CAP	SHC	CAP	SHC	CAP	SHC	CAP	SHC	CAP	SHC	CAP	SHC		
21000	75	1135	830	1256	673	1369	506	1086	804	1204	649	1318	486	1034	777	1148	623	1259	462	987	753	1095	599	1198	439
	80	1138	954	1259	797	1370	629	1089	926	1208	773	1320	608	1039	898	1153	747	1262	584	993	873	1099	723	1201	560
	85	1146	1076	1262	920	1371	750	1099	1049	1212	896	1322	730	1050	1017	1154	869	1264	706	1008	985	1102	844	1204	682
	90	1176	1176	1265	1042	1372	872	1137	1137	1215	1018	1323	851	1094	1094	1159	989	1266	827	1054	1054	1106	963	1206	802
26000	75	1197	921	1315	725	1416	519	1145	894	1262	702	1363	499	1089	865	1202	676	1302	476	1037	837	1143	651	1238	453
	80	1205	1070	1318	877	1416	668	1154	1042	1266	854	1364	648	1099	1013	1204	827	1305	625	1048	987	1147	802	1240	601
	85	1226	1210	1320	1026	1418	817	1180	1176	1268	1001	1364	796	1132	1132	1210	973	1305	773	1087	1087	1151	946	1241	749
	90	1280	1280	1326	1173	1420	966	1238	1238	1276	1148	1364	944	1190	1190	1218	1120	1306	920	1141	1141	1160	1092	1242	894
31000	75	1242	1003	1354	774	1448	531	1188	975	1299	751	1393	511	1129	944	1237	725	1331	489	1075	917	1173	699	1265	466
	80	1256	1181	1356	951	1452	708	1202	1155	1301	927	1390	685	1148	1114	1240	899	1330	663	1097	1075	1178	870	1264	639
	85	1298	1298	1360	1123	1454	884	1252	1252	1308	1098	1389	861	1202	1202	1248	1071	1329	837	1150	1150	1186	1042	1263	811
	90	1352	1352	1368	1296	1456	1057	1308	1308	1317	1267	1391	1030	1257	1257	1262	1227	1327	1004	1202	1202	1204	1185	1261	977
36000	75	1277	1081	1380	819	1475	543	1222	1053	1324	797	1415	523	1133	1016	1260	769	1353	501	1104	993	1196	741	1285	478
	80	1298	1273	1382	1018	1478	747	1248	1236	1328	994	1410	722	1193	1193	1267	966	1347	700	1140	1140	1202	936	1283	678
	85	1352	1352	1386	1215	1479	948	1305	1305	1335	1192	1411	922	1252	1252	1275	1164	1345	895	1196	1196	1212	1135	1278	867
	90	1403	1403	1405	1389	1483	1143	1353	1353	1352	1352	1413	1115	1299	1299	1299	1299	1342	1085	1240	1240	1240	1240	1272	1056
41000	75	1305	1156	1400	862	1496	555	1249	1128	1344	838	1433	534	1187	1097	1279	809	1369	513	1128	1066	1213	779	1301	490
	80	1336	1336	1401	1082	1497	800	1288	1288	1347	1058	1428	761	1234	1234	1286	1030	1364	736	1177	1177	1220	1000	1296	710
	85	1389	1389	1409	1307	1499	1007	1342	1342	1354	1282	1428	978	1288	1288	1296	1249	1356	949	1229	1229	1233	1199	1286	920
	90	1447	1447	1447	1447	1504	1228	1388	1388	1388	1388	1432	1198	1327	1327	1327	1327	1327	1327	1327	1327	1327	1327	1327	1327
46000	75	1327	1229	1416	901	1512	567	1272	1201	1359	875	1448	546	1209	1163	1294	846	1383	525	1150	1119	1228	815	1314	502
	80	1369	1369	1416	1145	1513	821	1320	1320	1362	1121	1442	795	1265	1265	1300	1093	1377	769	1205	1205	1234	1063	1309	740
	85	1425	1425	1432	1393	1515	1064	1368	1368	1372	1344	1441	1034	1313	1313	1313	1301	1366	1003	1251	1251	1250	1250	1292	973
	90	1484	1484	1484	1484	1522	1311	1420	1420	1420	1419	1447	1281	1351	1351	1351	1351	1351	1351	1351	1351	1351	1351	1351	1351
51000	75	1344	1298	1428	937	1526	579	1291	1258	1372	911	1461	558	1231	1213	1307	881	1395	537	1169	1169	1239	850	1325	514
	80	1394	1394	1432	1209	1527	851	1345	1345	1373	1182	1454	824	1288	1288	1312	1154	1386	796	1227	1227	1245	1123	1317	766
	85	1454	1454	1456	1449	1528	1120	1393	1393	1392	1392	1452	1089	1330	1330	1330	1330	1375	1057	1266	1266	1266	1266	1298	1025
	90	1513	1513	1513	1513	1538	1394	1446	1446	1446	1445	1445	1362	1373	1373	1373	1373	1373	1373	1373	1373	1373	1373	1373	1373
54000	75	1356	1326	1434	958	1533	586	1303	1287	1378	932	1469	565	1241	1241	1313	902	1402	544	1182	1182	1245	870	1331	522
	80	1407	1407	1440	1247	1532	871	1357	1357	1378	1219	1459	841	1300	1300	1317	1191	1390	811	1238	1238	1251	1159	1321	782
	85	1470	1470	1469	1469	1534	1153	1406	1406	1405	1405	1458	1122	1340	1340	1340	1340	1379	1089	1273	1273	1273	1273	1301	1056
	90	1530	1530	1529	1529	1546	1443	1458	1458	1457	1457	1465	1401	1384	1384	1383	1383	1388	1346	1306	1306	1306	1306	1307	1289

Table 46. Gross cooling capacities – 130 tons – high capacity evaporator coil, 50Hz

CFM	Ent DB (°F)	Ambient Temperature (°F)																										
		85						95						105						115								
		61			67			73			61			67			73			61			67			73		
		CAP	SHC	SHC	CAP	SHC	SHC	CAP	SHC	SHC	CAP	SHC	SHC	CAP	SHC	SHC	CAP	SHC	SHC	CAP	SHC	SHC	CAP	SHC	SHC			
23000	75	1229	911	1352	730	1471	544	1181	885	1301	707	1419	523	1123	856	1243	681	1361	502	1068	829	1183	654	1297	478			
	80	1230	1048	1355	869	1471	681	1183	1026	1305	846	1422	661	1127	997	1248	820	1364	638	1076	966	1188	794	1300	613			
	85	1241	1186	1357	1008	1473	818	1193	1158	1309	985	1423	797	1151	1135	1249	957	1367	774	1111	1110	1192	932	1303	749			
	90	1283	1283	1359	1144	1474	954	1242	1242	1311	1119	1425	934	1197	1197	1256	1091	1369	911	1150	1150	1197	1063	1306	885			
26000	75	1262	967	1387	762	1502	553	1210	939	1334	739	1450	532	1153	908	1275	713	1390	511	1098	884	1213	687	1322	486			
	80	1270	1119	1389	918	1503	706	1219	1099	1338	895	1452	686	1165	1065	1280	870	1393	664	1108	1033	1219	843	1328	639			
	85	1289	1278	1391	1073	1504	860	1241	1241	1340	1048	1453	839	1195	1192	1283	1020	1395	817	1145	1145	1221	992	1330	792			
	90	1343	1343	1397	1224	1505	1013	1301	1301	1347	1199	1453	992	1254	1254	1291	1172	1396	972	1204	1204	1230	1143	1331	945			
30000	75	1302	1033	1422	803	1535	560	1250	1013	1369	780	1482	544	1190	984	1309	755	1420	522	1130	946	1245	728	1352	497			
	80	1312	1212	1424	981	1536	740	1262	1183	1372	959	1482	719	1204	1153	1313	934	1423	697	1146	1122	1248	906	1356	672			
	85	1348	1347	1428	1154	1538	916	1305	1304	1376	1129	1479	893	1255	1255	1318	1101	1424	873	1203	1203	1254	1073	1357	848			
	90	1408	1408	1435	1327	1540	1092	1365	1364	1386	1303	1483	1068	1316	1316	1329	1276	1425	1044	1263	1263	1268	1247	1358	1016			
35000	75	1341	1118	1456	852	1567	577	1287	1089	1401	829	1512	558	1226	1057	1339	804	1449	535	1164	1028	1272	777	1379	511			
	80	1369	1325	1457	1058	1569	781	1301	1293	1404	1029	1509	759	1251	1250	1343	1001	1450	738	1196	1196	1277	972	1381	713			
	85	1412	1411	1462	1252	1570	985	1367	1366	1410	1227	1508	962	1316	1315	1352	1200	1450	939	1260	1260	1287	1171	1382	910			
	90	1469	1469	1475	1454	1573	1182	1426	1426	1426	1425	1509	1155	1375	1375	1375	1373	1451	1131	1319	1319	1319	1318	1384	1103			
40000	75	1370	1191	1480	899	1590	589	1316	1164	1424	874	1537	571	1254	1134	1361	845	1472	548	1191	1102	1293	816	1400	524			
	80	1398	1397	1482	1122	1593	821	1351	1349	1428	1097	1531	799	1298	1297	1367	1071	1471	778	1240	1240	1297	1039	1401	754			
	85	1460	1460	1489	1348	1594	1048	1414	1414	1437	1323	1529	1021	1362	1362	1379	1297	1470	997	1304	1304	1314	1267	1401	969			
	90	1523	1523	1522	1522	1598	1269	1472	1471	1471	1470	1533	1243	1420	1420	1419	1417	1469	1216	1362	1362	1361	1361	1403	1189			
45000	75	1396	1269	1501	941	1613	599	1340	1241	1444	913	1557	584	1279	1210	1380	885	1490	561	1215	1177	1311	855	1417	537			
	80	1437	1436	1502	1188	1613	861	1389	1388	1448	1165	1554	842	1335	1334	1387	1138	1490	815	1276	1276	1319	1108	1419	784			
	85	1500	1500	1515	1443	1613	1103	1452	1452	1461	1418	1547	1077	1399	1399	1403	1392	1485	1055	1339	1339	1339	1339	1416	1027			
	90	1567	1567	1565	1565	1618	1356	1511	1511	1509	1508	1552	1329	1454	1454	1454	1454	1486	1302	1395	1395	1394	1394	1418	1274			
50000	75	1417	1343	1517	980	1631	615	1396	1321	1460	952	1574	597	1302	1284	1396	923	1505	574	1236	1236	1325	893	1431	550			
	80	1468	1468	1518	1253	1631	899	1421	1420	1464	1230	1568	873	1366	1365	1403	1202	1504	846	1305	1305	1334	1170	1434	815			
	85	1536	1536	1540	1538	1629	1166	1480	1480	1484	1484	1562	1138	1428	1428	1427	1427	1497	1112	1367	1367	1366	1366	1427	1084			
	90	1600	1600	1600	1600	1638	1443	1545	1545	1542	1542	1569	1415	1483	1483	1482	1482	1502	1388	1422	1422	1420	1420	1430	1359			
55000	75	1437	1416	1529	1016	1647	628	1379	1377	1473	989	1589	609	1322	1320	1408	960	1518	587	1260	1260	1338	929	1443	560			
	80	1494	1494	1535	1320	1644	930	1447	1447	1477	1294	1580	903	1391	1391	1416	1265	1516	876	1329	1329	1346	1233	1445	844			
	85	1563	1563	1567	1567	1643	1224	1507	1507	1509	1509	1575	1196	1452	1452	1455	1455	1507	1169	1390	1390	1397	1397	1437	1140			
	90	1632	1632	1632	1632	1655	1528	1570	1570	1570	1570	1584	1499	1509	1509	1507	1507	1515	1471	1442	1442	1442	1442	1439	1438			
58000	75	1444	1444	1536	1038	1656	636	1393	1391	1480	1011	1596	617	1335	1334	1415	981	1526	594	1272	1272	1344	950	1450	567			
	80	1510	1509	1544	1359	1652	948	1461	1461	1485	1332	1586	921	1404	1404	1423	1303	1522	893	1341	1341	1354	1271	1451	862			
	85	1581	1581	1581	1649	1649	1259	1521	1521	1524	1524	1581	1231	1465	1465	1472	1472	1513	1202	1402	1402	1410	1410	1442	1174			
	90	1649	1649	1649	1649	1665	1579	1584	1584	1584	1584	1592	1549	1522	1520	1521	1521	1521	1519	1455	1455	1454	1454	1451	1451			



Performance Data

Table 47. Gross cooling capacities – 130 tons eFlex™ variable speed – high capacity evaporator coil, 50Hz

CFM	Ent DB (°F)	Ambient Temperature (°F)																							
		85				95				105				115											
		61		67		73		61		67		73		61		67		73							
CAP	SHC	CAP	SHC	CAP	SHC	CAP	SHC	CAP	SHC	CAP	SHC	CAP	SHC	CAP	SHC	CAP	SHC	CAP	SHC						
23000	75	1277	936	1407	755	1522	563	1221	906	1349	728	1465	540	1163	877	1285	699	1399	514	1113	851	1227	673	1332	488
	80	1279	1075	1410	895	1523	701	1225	1046	1353	868	1466	678	1167	1013	1290	839	1401	651	1118	986	1231	812	1334	625
	85	1289	1214	1413	1035	1524	839	1235	1184	1356	1008	1467	815	1181	1148	1292	978	1403	789	1121	1121	1233	950	1335	761
	90	1325	1325	1415	1173	1524	975	1280	1280	1359	1144	1468	952	1231	1231	1297	1113	1404	925	1186	1186	1238	1084	1336	897
26000	75	1315	993	1444	788	1550	570	1257	962	1384	761	1492	547	1196	931	1318	732	1425	522	1144	904	1257	705	1355	496
	80	1322	1148	1446	945	1552	725	1265	1117	1388	918	1492	701	1205	1084	1323	889	1426	676	1153	1056	1260	861	1357	649
	85	1337	1303	1449	1101	1554	880	1286	1264	1391	1073	1492	855	1231	1223	1325	1042	1426	829	1183	1183	1263	1012	1357	802
	90	1390	1390	1453	1253	1556	1035	1343	1343	1396	1225	1492	1008	1290	1290	1333	1194	1426	982	1240	1240	1270	1163	1357	954
30000	75	1357	1063	1480	828	1582	580	1297	1031	1419	801	1519	556	1233	998	1352	772	1451	531	1178	969	1286	745	1379	506
	80	1369	1241	1482	1007	1586	758	1310	1209	1421	981	1516	732	1248	1176	1354	950	1449	706	1191	1144	1289	921	1378	680
	85	1398	1398	1485	1182	1588	936	1348	1348	1426	1154	1515	907	1293	1293	1360	1123	1447	881	1241	1241	1294	1092	1377	856
	90	1458	1458	1491	1356	1590	1112	1408	1408	1434	1328	1517	1083	1353	1353	1370	1297	1447	1054	1296	1296	1305	1256	1376	1024
35000	75	1399	1145	1512	875	1614	593	1337	1113	1450	849	1543	568	1271	1079	1381	821	1474	543	1211	1049	1311	792	1402	518
	80	1415	1353	1513	1081	1617	798	1356	1316	1452	1053	1541	770	1295	1270	1384	1021	1468	744	1238	1227	1315	990	1396	718
	85	1463	1463	1516	1279	1618	1003	1412	1412	1458	1251	1542	975	1353	1353	1391	1220	1465	945	1295	1295	1322	1188	1394	917
	90	1517	1517	1526	1476	1621	1203	1465	1465	1470	1435	1544	1171	1406	1406	1408	1390	1464	1138	1343	1343	1343	1343	1388	1107
40000	75	1430	1224	1534	921	1639	605	1368	1192	1472	895	1563	579	1300	1158	1401	865	1493	555	1238	1126	1331	835	1420	530
	80	1454	1438	1535	1147	1639	837	1397	1397	1475	1120	1561	810	1337	1337	1406	1088	1482	782	1278	1278	1335	1056	1413	757
	85	1510	1510	1541	1374	1641	1069	1457	1457	1480	1345	1562	1037	1396	1396	1413	1314	1480	1003	1333	1333	1343	1282	1404	972
	90	1569	1569	1568	1568	1646	1291	1504	1504	1504	1504	1565	1257	1438	1438	1438	1438	1481	1223	1371	1371	1371	1371	1398	1189
45000	75	1456	1300	1552	964	1658	617	1393	1269	1490	937	1579	590	1325	1234	1418	905	1508	567	1260	1201	1347	872	1434	542
	80	1490	1490	1553	1213	1658	877	1435	1435	1491	1185	1578	849	1374	1374	1422	1153	1498	819	1311	1311	1350	1121	1428	793
	85	1548	1548	1567	1469	1660	1128	1488	1488	1497	1437	1577	1094	1426	1426	1431	1391	1493	1060	1359	1359	1361	1338	1410	1026
	90	1610	1610	1610	1610	1666	1377	1540	1540	1540	1540	1582	1343	1466	1466	1466	1466	1495	1308	1391	1391	1391	1391	1409	1272
50000	75	1476	1375	1567	1003	1674	629	1415	1343	1503	975	1593	602	1345	1300	1432	942	1521	579	1281	1251	1359	909	1447	554
	80	1519	1519	1571	1279	1672	914	1464	1464	1503	1249	1591	885	1401	1401	1434	1217	1511	852	1335	1335	1362	1184	1436	820
	85	1582	1582	1589	1553	1674	1186	1514	1514	1517	1497	1589	1152	1446	1446	1446	1445	1503	1116	1377	1377	1377	1377	1418	1081
	90	1645	1645	1645	1645	1684	1464	1571	1571	1570	1570	1596	1428	1491	1491	1491	1491	1491	1491	1410	1410	1410	1409	1419	1353
55000	75	1492	1444	1578	1040	1687	641	1433	1400	1514	1011	1606	614	1366	1350	1443	978	1533	591	1299	1299	1370	944	1459	567
	80	1544	1544	1586	1345	1685	948	1486	1486	1513	1311	1602	914	1422	1422	1444	1280	1518	879	1355	1355	1371	1245	1443	847
	85	1610	1610	1612	1610	1687	1244	1539	1539	1539	1539	1600	1208	1464	1464	1463	1463	1511	1172	1390	1390	1390	1390	1424	1135
	90	1674	1674	1674	1674	1699	1549	1594	1594	1594	1594	1608	1511	1511	1511	1511	1511	1511	1511	1457	1426	1426	1426	1426	1429
58000	75	1503	1473	1585	1062	1694	648	1440	1440	1520	1033	1613	621	1375	1375	1448	1000	1540	598	1310	1310	1375	965	1465	575
	80	1559	1559	1594	1383	1692	966	1497	1497	1518	1348	1608	932	1433	1432	1449	1316	1521	896	1364	1364	1376	1282	1446	863
	85	1626	1626	1626	1626	1694	1278	1551	1551	1551	1551	1606	1242	1475	1475	1474	1474	1516	1205	1398	1398	1397	1397	1428	1167
	90	1690	1690	1689	1689	1708	1599	1606	1606	1605	1605	1614	1550	1521	1521	1520	1520	1524	1487	1434	1434	1434	1434	1433	1433

Evaporative Condensing, 60 Hz, High Capacity Evaporator Coils

Table 48. Gross cooling capacities – 100 tons evaporative condensing – high capacity evaporator coil, 60Hz

CFM	Ent DB (°F)	Ambient Temperature (°F)						Ambient Temperature (°F)											
		60			65			70			73								
		61	67	73	61	67	73	61	67	73	61	67	73						
		CAP	SHC	SHC	CAP	SHC	SHC	CAP	SHC	SHC	CAP	SHC	SHC	CAP	SHC	SHC			
16000	75	1042	733	1153	640	1277	531	1030	744	1140	634	1262	522	1017	736	1125	627	1246	514
	80	1046	845	1157	734	—	—	1034	838	1144	727	1263	613	1021	830	1130	720	1250	607
	85	1049	934	1161	827	1284	715	1037	927	1148	820	1270	708	1025	919	1134	812	1254	701
	90	1053	1024	1165	919	1288	807	1041	1017	1152	912	1274	800	1028	1008	1138	905	1258	792
20000	75	1111	831	1227	692	1350	549	1098	823	1212	685	1333	542	1084	815	1196	677	1314	534
	80	1116	942	1233	808	1351	662	1102	934	1218	800	1342	660	1088	926	1202	792	1323	650
	85	1128	1056	1238	922	1364	781	1115	1048	1224	915	1348	773	1100	1040	1208	907	1331	765
	90	1139	1139	1242	1032	1370	895	1127	1127	1228	1024	1354	888	1113	1113	1212	1016	1336	880
25000	75	1170	915	1291	748	1408	567	1155	907	1275	741	1389	559	1139	898	1257	732	1368	550
	80	1184	1055	1299	891	1410	707	1170	1047	1283	883	1406	706	1154	1038	1265	875	1382	695
	85	1206	1200	1303	1026	1433	856	1192	1192	1288	1018	1416	849	1178	1178	1270	1009	1396	840
	90	1228	1228	1317	1164	1440	997	1255	1255	1302	1156	1423	990	1201	1201	1285	1147	1403	981
30000	75	1217	994	1336	798	1444	580	1202	985	1318	791	1423	572	1185	976	1299	782	1400	563
	80	1237	1163	1340	961	1449	753	1222	1154	1323	952	1426	739	1205	1144	1304	943	1430	741
	85	1282	1282	1356	1124	1481	927	1268	1268	1339	1116	1462	919	1253	1253	1321	1106	1442	911
	90	1349	1349	1376	1291	1486	1085	1315	1315	1359	1282	1468	1077	1302	1302	1341	1273	1447	1067
33000	75	1240	1039	1344	824	1458	587	1224	1030	1325	814	1437	578	1207	1021	1306	805	1413	569
	80	1264	1226	1363	1001	1491	782	1249	1217	1346	992	1472	774	1232	1207	1327	982	1424	757
	85	1322	1322	1382	1181	1494	962	1308	1308	1365	1173	1475	953	1292	1292	1345	1163	1454	944
	90	1380	1380	1406	1366	1512	1138	1367	1367	1389	1357	1493	1129	1353	1353	1371	1347	1472	1119
36000	75	1260	1081	1362	849	1469	593	1244	1072	1344	840	1447	584	1226	1062	1323	830	1422	575
	80	1290	1288	1384	1039	1510	808	1274	1274	1366	1030	1489	799	1257	1257	1346	1020	1438	779
	85	1358	1358	1404	1238	1514	996	1343	1343	1387	1228	1495	987	1327	1326	1367	1218	1473	977
	90	1426	1428	1435	1435	1534	1189	1411	1411	1418	1418	1514	1180	1396	1396	1398	1398	1493	1170
40000	75	1284	1137	1383	879	1479	600	1267	1128	1364	869	1456	591	1248	1117	1343	859	1431	582
	80	1323	1323	1406	1090	1529	839	1308	1308	1388	1080	1508	831	1292	1291	1368	1070	1485	822
	85	1399	1399	1431	1311	1538	1041	1383	1383	1412	1302	1518	1032	1366	1366	1393	1292	1495	1021
	90	1475	1475	1475	1475	1559	1256	1458	1458	1458	1458	1539	1247	1441	1441	1441	1441	1517	1237

**Table 48. Gross cooling capacities – 100 tons evaporative condensing – high capacity evaporator coil, 60Hz
(continued)**

CFM	Ent DB (°F)	Ambient Temperature (°F)						Ambient Temperature (°F)					
		75			80			75			80		
		Entering Wet Bulb (°F)			Entering Wet Bulb (°F)			Entering Wet Bulb (°F)			Entering Wet Bulb (°F)		
		61	67	73	61	67	73	61	67	73	61	67	73
		CAP	SHC	CAP	SHC	CAP	SHC	CAP	SHC	CAP	SHC	CAP	SHC
16000	75	1003	728	1110	619	1228	506	988	720	1093	609	1210	498
	80	1007	822	1115	712	1232	601	993	813	1099	703	1215	590
	85	1011	911	1119	804	1237	693	997	902	1103	796	1219	683
	90	1015	1000	1123	897	1241	784	1001	990	1107	888	1224	775
20000	75	1068	807	1179	669	1295	525	1052	798	1160	658	1274	516
	80	1073	917	1185	784	1296	638	1057	907	1168	775	1285	635
	85	1086	1031	1191	898	1312	757	1070	1021	1172	889	1293	749
	90	1098	1098	1195	1007	1318	871	1083	1083	1178	997	1298	862
25000	75	1123	888	1238	723	1346	541	1105	878	1218	713	1323	532
	80	1138	1028	1246	866	1361	686	1120	1018	1227	857	1345	682
	85	1162	1162	1252	999	1376	832	1147	1147	1233	989	1355	823
	90	1187	1187	1266	1137	1383	972	1174	1174	1248	1127	1361	963
30000	75	1167	966	1279	773	1376	553	1148	955	1243	756	1351	543
	80	1188	1134	1284	932	1409	734	1169	1124	1264	922	1386	724
	85	1238	1238	1301	1096	1420	902	1221	1221	1281	1086	1387	888
	90	1288	1288	1322	1263	1426	1057	1287	1287	1302	1253	1401	1046
33000	75	1188	1010	1285	796	1388	559	1169	999	1264	786	1362	549
	80	1214	1197	1306	972	1428	757	1196	1186	1286	961	1405	749
	85	1276	1275	1325	1152	1432	933	1259	1259	1305	1142	1408	923
	90	1344	1344	1352	1337	1450	1109	1321	1321	1332	1326	1427	1099
36000	75	1207	1051	1302	819	1396	565	1187	1040	1280	808	1370	554
	80	1238	1238	1325	1010	1424	766	1221	1221	1304	999	1412	769
	85	1309	1309	1346	1208	1451	967	1291	1291	1326	1197	1427	956
	90	1380	1380	1380	1380	1471	1160	1362	1362	1361	1361	1447	1149
40000	75	1229	1106	1321	847	1404	572	1209	1095	1298	836	1378	571
	80	1274	1274	1346	1059	1461	813	1256	1256	1324	1048	1436	803
	85	1348	1348	1372	1281	1472	1011	1329	1329	1350	1270	1448	1000
	90	1422	1421	1422	1422	1494	1226	1402	1402	1402	1402	1470	1216

Table 49. Gross cooling capacities – 118 tons evaporative condensing – high capacity evaporator coil, 60Hz

CFM	Ent DB (°F)	Ambient Temperature (°F)									Ambient Temperature (°F)										
		60			65			70			60			65			70				
		Entering Wet Bulb (°F)			Entering Wet Bulb (°F)			Entering Wet Bulb (°F)			Entering Wet Bulb (°F)			Entering Wet Bulb (°F)			Entering Wet Bulb (°F)				
		61	67	73	61	67	73	61	67	73	61	67	73	61	67	73	61	67	73		
		CAP	SHC	CAP	SHC	CAP	SHC	CAP	SHC	CAP	SHC	CAP	SHC	CAP	SHC	CAP	SHC	CAP	SHC	CAP	SHC
19000	75	1229	874	1360	778	1502	648	1214	895	1343	769	1483	642	1197	885	1324	758	1461	627		
	80	1235	1016	1365	889	1508	761	1220	1007	1349	880	1489	749	1202	996	1330	868	1467	738		
	85	1240	1122	1370	999	1513	869	1226	1113	1354	989	1496	860	1209	1101	1335	979	1475	850		
	90	1246	1228	1376	1109	1519	978	1232	1218	1360	1100	1501	970	1215	1207	1341	1088	1481	959		
23000	75	1297	985	1430	830	1570	668	1281	976	1413	821	1549	659	1262	964	1391	807	1525	647		
	80	1303	1112	1438	962	1583	806	1287	1103	1420	953	1561	794	1268	1091	1400	942	1540	785		
	85	1317	1244	1445	1095	1591	937	1301	1234	1427	1085	1572	927	1283	1222	1407	1074	1549	916		
	90	1332	1332	1450	1221	1598	1068	1316	1316	1433	1211	1578	1058	1298	1298	1413	1199	1556	1047		
28000	75	1355	1069	1495	887	1626	687	1338	1059	1475	876	1603	676	1318	1046	1452	865	1577	664		
	80	1372	1227	1504	1047	1650	856	1355	1216	1485	1037	1628	843	1335	1204	1462	1026	1604	834		
	85	1397	1390	1510	1199	1661	1014	1381	1380	1492	1188	1640	1004	1362	1362	1469	1176	1615	992		
	90	1422	1422	1527	1354	1670	1172	1407	1407	1508	1344	1649	1162	1390	1390	1486	1331	1624	1151		
33000	75	1405	1149	1522	928	1661	700	1386	1138	1501	920	1637	689	1365	1125	1480	914	1608	685		
	80	1427	1336	1546	1117	1697	898	1409	1325	1526	1107	1676	888	1388	1312	1502	1093	1649	879		
	85	1478	1478	1565	1298	1711	1086	1461	1461	1545	1287	1689	1076	1442	1442	1522	1274	1663	1064		
	90	1555	1555	1587	1483	1717	1261	1514	1514	1568	1472	1696	1250	1497	1497	1545	1459	1670	1237		
38000	75	1443	1225	1560	980	1683	710	1424	1214	1538	970	1657	699	1402	1200	1513	956	1626	696		
	80	1473	1441	1586	1186	1733	941	1455	1430	1565	1174	1710	931	1433	1417	1540	1161	1682	919		
	85	1546	1546	1609	1394	1739	1145	1529	1529	1588	1383	1716	1134	1509	1508	1564	1369	1689	1120		
	90	1629	1629	1640	1608	1761	1349	1603	1603	1620	1597	1739	1338	1584	1584	1596	1583	1712	1324		
43000	75	1475	1298	1588	1019	1696	719	1456	1287	1566	1008	1669	708	1432	1273	1541	993	1638	706		
	80	1517	1517	1618	1251	1737	972	1499	1499	1596	1240	1713	962	1478	1478	1571	1226	1685	950		
	85	1604	1604	1645	1488	1771	1203	1586	1586	1624	1476	1748	1192	1564	1564	1599	1462	1720	1178		
	90	1692	1692	1691	1691	1796	1434	1673	1673	1673	1673	1773	1423	1650	1649	1650	1650	1746	1409		
45000	75	1487	1327	1598	1034	1700	723	1467	1316	1576	1022	1673	712	1443	1301	1550	1008	1641	698		
	80	1536	1536	1629	1277	1748	990	1518	1518	1607	1265	1723	978	1496	1496	1582	1251	1694	964		
	85	1624	1624	1659	1525	1783	1226	1606	1606	1637	1513	1759	1215	1584	1584	1612	1499	1731	1201		
	90	1714	1714	1714	1714	1809	1468	1695	1695	1694	1694	1785	1457	1671	1671	1672	1672	1758	1443		

**Table 49. Gross cooling capacities – 118 tons evaporative condensing – high capacity evaporator coil, 60Hz
(continued)**

CFM	Ent DB (°F)	Ambient Temperature (°F)						Ambient Temperature (°F)					
		75			80			75			80		
		Entering Wet Bulb (°F)						Entering Wet Bulb (°F)					
		61	67	73	61	67	73	61	67	73	61	67	73
		CAP	SHC	SHC	CAP	SHC	SHC	CAP	SHC	SHC	CAP	SHC	SHC
19000	75	1180	874	1305	748	1440	620	1163	864	1286	738	1418	610
	80	1185	986	1311	858	1447	728	1168	976	1293	849	1427	721
	85	1192	1090	1316	968	1454	838	1175	1080	1298	958	1434	830
	90	1198	1195	1322	1078	1460	948	1182	1182	1304	1068	1440	938
23000	75	1243	953	1371	798	1501	636	1224	943	1351	788	1477	625
	80	1250	1079	1379	931	1517	774	1231	1068	1359	921	1494	761
	85	1265	1211	1386	1063	1526	905	1247	1200	1364	1052	1503	894
	90	1280	1280	1392	1187	1533	1036	1262	1262	1373	1176	1511	1025
28000	75	1297	1034	1430	853	1550	652	1277	1023	1408	844	1523	641
	80	1315	1192	1440	1014	1579	823	1295	1181	1418	1004	1554	809
	85	1345	1345	1448	1164	1591	981	1328	1328	1426	1152	1566	970
	90	1374	1374	1464	1319	1600	1139	1330	1330	1443	1308	1574	1127
33000	75	1343	1113	1456	901	1579	673	1323	1101	1430	885	1550	652
	80	1367	1299	1479	1081	1623	865	1346	1287	1456	1069	1596	854
	85	1424	1424	1499	1262	1637	1053	1405	1405	1476	1250	1598	1036
	90	1500	1500	1522	1446	1645	1225	1464	1464	1500	1434	1616	1211
38000	75	1380	1187	1489	943	1597	684	1358	1175	1464	930	1566	661
	80	1412	1404	1516	1148	1656	909	1391	1391	1492	1135	1627	895
	85	1489	1488	1540	1356	1663	1107	1468	1468	1516	1344	1636	1094
	90	1565	1565	1574	1571	1686	1311	1549	1549	1551	1551	1659	1298
43000	75	1410	1259	1515	979	1607	694	1387	1246	1489	966	1575	669
	80	1458	1457	1546	1212	1657	938	1437	1437	1521	1199	1628	924
	85	1543	1542	1575	1449	1693	1164	1521	1521	1550	1436	1665	1150
	90	1628	1627	1628	1628	1718	1395	1606	1606	1606	1606	1691	1382
45000	75	1420	1288	1524	994	1610	685	1398	1274	1498	980	1578	673
	80	1475	1475	1557	1237	1666	950	1454	1454	1531	1224	1637	936
	85	1562	1562	1587	1486	1703	1187	1540	1540	1562	1472	1675	1173
	90	1649	1649	1649	1649	1730	1429	1627	1627	1627	1626	1702	1415

Table 50. Gross cooling capacities – 128 tons evaporative condensing – high capacity evaporator coil, 60Hz

CFM	Ent DB (°F)	Ambient Temperature (°F)									Ambient Temperature (°F)									
		60			65			70			60			65			70			
		Entering Wet Bulb (°F)			Entering Wet Bulb (°F)			Entering Wet Bulb (°F)			Entering Wet Bulb (°F)			Entering Wet Bulb (°F)			Entering Wet Bulb (°F)			
	61	67	73	61	67	73	61	67	73	61	67	73	61	67	73	61	67	73		
	CAP	SHC	CAP	SHC	CAP	SHC	CAP	SHC	CAP	SHC	CAP	SHC	CAP	SHC	CAP	SHC	CAP	SHC	CAP	SHC
21000	75	1372	971	1516	862	1677	719	1355	993	1498	853	1657	709	1335	981	1477	840	1632	697	
	80	1376	1126	1523	985	1679	840	1360	1116	1505	975	1662	831	1340	1104	1483	963	1637	818	
	85	1378	1244	1528	1106	1688	963	1362	1233	1510	1096	1668	953	1343	1221	1488	1084	1644	940	
	90	1381	1362	1532	1227	1682	1078	1365	1351	1514	1217	1668	1068	1345	1337	1493	1205	1650	1061	
26000	75	1458	1105	1607	927	1764	745	1440	1094	1587	917	1741	734	1418	1081	1563	904	1713	721	
	80	1516	1278	1616	1078	1776	897	1448	1240	1596	1067	1754	888	1474	1251	1572	1055	1726	872	
	85	1475	1397	1622	1227	1786	1047	1457	1386	1603	1216	1764	1037	1436	1373	1579	1203	1738	1024	
	90	1433	1433	1625	1370	1793	1195	1465	1465	1605	1359	1771	1184	1398	1398	1582	1345	1745	1171	
31000	75	1514	1191	1674	985	1821	763	1495	1179	1652	975	1795	752	1472	1165	1626	961	1765	738	
	80	1530	1365	1684	1163	1843	947	1511	1353	1663	1152	1821	938	1488	1339	1637	1139	1792	922	
	85	1555	1545	1686	1333	1857	1125	1536	1533	1665	1321	1833	1114	1515	1515	1639	1307	1805	1100	
	90	1579	1579	1701	1505	1865	1299	1562	1562	1680	1493	1841	1288	1542	1542	1655	1479	1814	1275	
36000	75	1566	1273	1723	1039	1857	776	1545	1260	1701	1028	1829	764	1521	1246	1674	1014	1797	750	
	80	1587	1476	1735	1244	1883	987	1567	1464	1701	1225	1870	983	1542	1449	1674	1210	1840	968	
	85	1636	1636	1742	1434	1910	1197	1619	1619	1720	1422	1885	1186	1597	1597	1694	1407	1856	1172	
	90	1686	1686	1763	1635	1910	1392	1708	1708	1741	1622	1886	1380	1652	1652	1715	1608	1857	1365	
41000	75	1607	1350	1740	1083	1879	787	1586	1338	1715	1067	1850	774	1560	1323	1686	1053	1816	759	
	80	1635	1583	1766	1306	1934	1036	1614	1571	1743	1294	1908	1025	1590	1556	1715	1279	1877	1011	
	85	1709	1709	1788	1532	1950	1267	1690	1690	1765	1519	1908	1248	1667	1667	1737	1504	1878	1233	
	90	1783	1783	1816	1762	1956	1481	1766	1766	1793	1749	1931	1468	1745	1749	1767	1734	1901	1453	
46000	75	1642	1426	1770	1123	1893	795	1620	1412	1745	1110	1863	789	1594	1397	1716	1094	1828	768	
	80	1680	1680	1800	1373	2057	1114	1658	1657	1776	1360	2027	1102	1634	1634	1748	1344	1992	1087	
	85	1771	1771	1826	1627	1969	1320	1750	1750	1803	1614	1942	1307	1726	1726	1774	1599	1911	1291	
	90	1865	1865	1864	1864	1994	1568	1844	1844	1844	1843	1968	1555	1819	1819	1819	1819	1937	1540	
51000	75	1671	1495	1795	1160	1901	803	1649	1482	1770	1146	1870	804	1622	1466	1740	1129	1834	775	
	80	1726	1726	1829	1436	2036	1137	1705	1705	1804	1423	2008	1129	1681	1681	1775	1407	1975	1114	
	85	1823	1823	1860	1721	1998	1376	1802	1802	1836	1708	1971	1363	1777	1777	1807	1692	1939	1347	
	90	1930	1930	1921	1921	2026	1654	1900	1900	1900	1899	1999	1640	1873	1873	1874	1873	1968	1625	
54000	75	1687	1537	1808	1181	1904	807	1664	1524	1782	1167	1873	809	1637	1507	1752	1150	1836	780	
	80	1752	1752	1844	1474	2006	1154	1731	1731	1819	1460	1978	1141	1706	1706	1790	1444	1945	1125	
	85	1852	1852	1878	1776	2013	1410	1830	1830	1854	1763	1986	1396	1804	1804	1825	1747	1954	1379	
	90	1953	1953	1952	1952	2043	1704	1929	1929	1929	1929	2016	1691	1902	1902	1903	1903	1984	1675	

**Table 50. Gross cooling capacities – 128 tons evaporative condensing – high capacity evaporator coil, 60Hz
(continued)**

CFM	Ent DB (°F)	Ambient Temperature (°F)											
		75						80					
		Entering Wet Bulb (°F)			73			Entering Wet Bulb (°F)					
		61	67	73	61	67	73	61	67	73			
		CAP	SHC	CAP	SHC	CAP	SHC	CAP	SHC	CAP	SHC		
21000	75	1316	970	1455	829	1608	687	1298	959	1434	818	1584	676
	80	1321	1092	1462	951	1614	808	1302	1081	1441	940	1591	797
	85	1324	1208	1467	1072	1621	929	1306	1197	1447	1061	1598	918
	90	1327	1325	1472	1193	1624	1011	1309	1309	1451	1181	1604	1038
26000	75	1397	1069	1540	892	1686	708	1376	1057	1516	879	1658	696
	80	1451	1237	1549	1042	1701	861	1377	1198	1526	1030	1676	851
	85	1415	1360	1556	1191	1712	1011	1395	1348	1532	1179	1686	999
	90	1379	1379	1559	1332	1724	1162	1413	1413	1532	1318	1653	2135
31000	75	1449	1152	1601	949	1735	724	1427	1139	1576	936	1704	711
	80	1466	1326	1612	1126	1764	910	1444	1313	1587	1114	1736	898
	85	1495	1495	1615	1293	1778	1088	1475	1475	1590	1280	1750	1076
	90	1524	1524	1631	1465	1786	1262	1507	1507	1606	1452	1759	1249
36000	75	1497	1232	1647	1001	1765	736	1473	1218	1620	988	1732	722
	80	1519	1435	1648	1196	1796	948	1496	1421	1622	1182	1782	943
	85	1576	1576	1668	1393	1827	1160	1556	1555	1641	1379	1798	1147
	90	1634	1634	1689	1594	1827	1350	1638	1637	1663	1580	1798	1337
41000	75	1536	1308	1658	1040	1782	745	1511	1294	1630	1026	1748	743
	80	1566	1541	1688	1264	1847	998	1542	1527	1660	1249	1816	985
	85	1645	1645	1710	1489	1848	1218	1622	1622	1683	1475	1818	1204
	90	1724	1724	1741	1720	1871	1439	1703	1703	1715	1706	1838	1424
46000	75	1568	1382	1687	1078	1792	753	1542	1367	1657	1063	1757	752
	80	1611	1611	1720	1329	1837	1015	1588	1588	1691	1313	1922	1059
	85	1703	1702	1747	1584	1881	1276	1679	1678	1718	1569	1850	1261
	90	1795	1795	1794	1794	1907	1525	1769	1769	1770	1770	1876	1510
51000	75	1596	1453	1710	1113	1798	761	1569	1438	1679	1097	1879	791
	80	1657	1657	1746	1391	1899	1082	1633	1632	1717	1375	1868	1066
	85	1752	1752	1779	1676	1908	1331	1727	1726	1750	1661	1876	1316
	90	1849	1848	1848	1848	1936	1609	1823	1823	1823	1822	1905	1594
54000	75	1611	1495	1722	1133	1925	811	1584	1480	1691	1116	1775	769
	80	1681	1681	1760	1428	1912	1103	1656	1656	1731	1412	1880	1091
	85	1779	1778	1796	1731	1922	1363	1753	1753	1768	1716	1890	1348
	90	1877	1877	1877	1876	1952	1659	1852	1852	1851	1850	1921	1644

Table 51. Gross cooling capacities – 140 tons evaporative condensing – high capacity evaporator coil, 60Hz

CFM	Ent DB (°F)	Ambient Temperature (°F)																	
		60						65						70					
		Entering Wet Bulb (°F)						Entering Wet Bulb (°F)						Entering Wet Bulb (°F)					
		61	67	73	CAP	SHC	SHC	61	67	73	CAP	SHC	SHC	61	67	73	CAP	SHC	SHC
21000	75	1455	1016	1610	907	1784	764	1438	1038	1591	897	1762	754	1417	1025	1569	883	1737	741
	80	1459	1172	1616	1030	1785	885	1442	1161	1597	1020	1764	875	1422	1148	1566	1002	1739	861
	85	1464	1295	1620	1152	1791	1007	1443	1281	1602	1142	1770	997	1422	1267	1575	1126	1746	984
	90	1468	1418	1624	1274	1820	2284	1443	1400	1606	1263	1816	2277	1423	1386	1584	1250	1746	2251
26000	75	1553	1154	1713	975	1886	794	1534	1142	1692	965	1862	782	1511	1129	1667	950	1834	769
	80	1614	1334	1721	1127	1894	946	1537	1292	1700	1115	1870	935	1518	1276	1676	1102	1839	918
	85	1566	1449	1727	1276	1902	1094	1547	1437	1706	1265	1879	1084	1525	1423	1682	1251	1852	1070
	90	1518	1518	1734	1425	2744	2197	1557	1557	1713	1414	1886	1232	1532	1532	1688	1400	1859	1218
31000	75	1626	1249	1788	1036	1956	815	1605	1238	1733	1009	1930	803	1581	1224	1739	1009	1899	788
	80	1632	1420	1798	1214	1971	995	1611	1407	1776	1202	1947	986	1587	1393	1749	1188	1917	970
	85	1651	1597	1806	1391	1983	1174	1632	1585	1819	1395	1958	1162	1608	1570	1757	1365	1929	1148
	90	1671	1671	1812	1559	1991	1349	1652	1652	1790	1547	1967	1337	1629	1629	1764	1532	1942	1326
36000	75	1675	1330	1845	1090	2004	831	1653	1318	1822	1078	1976	818	1628	1302	1793	1063	1942	803
	80	1694	1532	1857	1295	2030	1042	1673	1520	1833	1283	2004	1032	1648	1504	1805	1269	1973	1016
	85	1729	1729	1861	1491	2044	1248	1709	1709	1837	1478	2018	1236	1687	1687	1810	1463	1988	1222
	90	1763	1763	1880	1691	2054	1450	1746	1746	1857	1678	2027	1437	1727	1727	1829	1662	1997	1423
41000	75	1722	1410	1890	1141	2037	843	1699	1397	1865	1129	2007	830	1672	1381	1835	1115	1972	815
	80	1747	1641	1891	1366	2076	1087	1725	1628	1866	1352	2049	1075	1698	1612	1837	1337	2016	1060
	85	1807	1807	1912	1590	2092	1319	1788	1788	1888	1577	2065	1307	1764	1764	1859	1561	2033	1292
	90	1868	1868	1937	1818	2094	1539	1851	1851	1913	1805	2065	1525	1830	1830	1885	1789	2033	1509
46000	75	1760	1486	1925	1190	2059	853	1737	1473	1899	1178	2027	840	1709	1456	1868	1163	1991	824
	80	1793	1747	1931	1434	2112	1129	1770	1734	1905	1420	2084	1117	1744	1718	1875	1404	2051	1102
	85	1875	1875	1955	1687	2129	1387	1855	1854	1930	1673	2101	1375	1830	1829	1901	1657	2068	1360
	90	1958	1958	1989	1945	2137	1627	1939	1939	1965	1931	2109	1614	1916	1916	1936	1915	2077	1598
51000	75	1793	1558	1932	1226	2074	862	1769	1544	1905	1211	2041	849	1741	1527	1874	1194	2003	833
	80	1835	1835	1964	1499	2142	1170	1812	1811	1937	1485	2112	1158	1786	1786	1907	1468	2078	1143
	85	1934	1934	1993	1781	2146	1439	1912	1912	1967	1768	2117	1425	1886	1886	1936	1751	2084	1408
	90	2037	2037	2036	2036	2173	1714	2013	2013	2013	2013	2145	1700	1986	1986	1987	1986	2111	1684
54000	75	1811	1601	1947	1248	2080	868	1787	1586	1920	1234	2046	854	1758	1569	1888	1216	2008	838
	80	1862	1862	1981	1537	2156	1194	1840	1840	1954	1523	2127	1182	1814	1814	1923	1506	2092	1167
	85	1966	1966	2013	1838	2163	1473	1943	1943	1987	1824	2134	1459	1916	1916	1956	1807	2100	1442
	90	2069	2069	2070	2070	2192	1765	2047	2047	2047	2047	2163	1751	2019	2018	2019	2019	2130	1734
58000	75	1832	1656	1965	1277	2086	874	1808	1642	1938	1262	2052	860	1778	1624	1905	1244	2013	844
	80	1897	1897	2002	1587	2173	1225	1874	1874	1975	1573	2143	1213	1848	1847	1943	1555	2107	1198
	85	2004	2004	2038	1912	2184	1518	1981	1981	2011	1897	2155	1503	1953	1953	1980	1880	2120	1486
	90	2111	2111	2111	2111	2215	1833	2088	2088	2087	2087	2186	1819	2064	2064	2059	2058	2152	1802



Performance Data

Table 51. Gross cooling capacities – 140 tons evaporative condensing – high capacity evaporator coil, 60Hz
(continued)

CFM	Ent DB (°F)	Ambient Temperature (°F)									Ambient Temperature (°F)															
		75						80			75						80									
		Entering Wet Bulb (°F)			73			61			67			61			67			73						
		CAP	SHC	CAP	SHC	CAP	SHC	CAP	SHC	CAP	SHC	CAP	SHC	CAP	SHC	CAP	SHC	CAP	SHC	CAP	SHC					
21000	75	1397	1013	1547	872	1712	728	1378	1002	1524	859	1687	718	80	1402	1136	1553	995	1714	849	1382	1124	1531	983	1689	838
	85	1403	1254	1558	1116	1722	971	1384	1242	1536	1104	1697	959	90	1404	1373	1562	1237	1793	2236	1385	1361	1540	1225	1775	2234
	75	1489	1116	1643	938	1806	755	1467	1104	1618	925	1777	742	80	1546	1291	1651	1089	1815	906	1475	1250	1627	1076	1788	894
	85	1503	1409	1671	1244	1825	1057	1482	1396	1633	1225	1798	1045	90	1461	1461	1691	1399	1835	1207	1489	1489	1639	1374	1809	1195
31000	75	1557	1210	1712	996	1868	774	1533	1197	1686	984	1837	761	80	1629	1409	1723	1175	1888	956	1540	1364	1696	1161	1859	944
	85	1586	1556	1730	1351	1900	1135	1563	1543	1770	1363	1871	1122	90	1542	1542	1738	1517	1909	1309	1586	1586	1784	1534	1884	1300
	75	1603	1287	1765	1050	1909	789	1577	1273	1737	1037	1876	782	80	1623	1489	1777	1255	1942	1003	1598	1475	1749	1242	1912	990
	85	1665	1665	1779	1446	1957	1208	1643	1643	1755	1433	1926	1195	90	1708	1708	1802	1647	1966	1409	1689	1689	1775	1633	1937	1396
41000	75	1646	1365	1806	1100	1936	800	1619	1350	1776	1087	1901	794	80	1673	1597	1809	1321	1984	1046	1646	1582	1780	1306	1952	1033
	85	1741	1741	1831	1546	2001	1278	1718	1717	1802	1531	1969	1265	90	1809	1809	1857	1774	2002	1494	1789	1789	1830	1759	1973	1480
	75	1682	1441	1838	1149	1954	809	1655	1425	1784	1125	1916	805	80	1717	1702	1845	1388	2018	1089	1691	1686	1816	1372	1984	1075
	85	1805	1805	1871	1641	2020	1336	1781	1780	1842	1626	1986	1320	90	1893	1893	1908	1899	2045	1582	1870	1870	1880	1880	2012	1567
51000	75	1713	1514	1842	1178	1966	824	1684	1497	1811	1161	1926	815	80	1761	1761	1876	1452	2044	1129	1736	1736	1845	1436	2009	1115
	85	1860	1860	1906	1735	2051	1392	1835	1834	1876	1719	2017	1376	90	1959	1959	1960	1959	2079	1668	1846	1846	1934	1933	2045	1652
	75	1729	1557	1856	1199	1970	823	1700	1540	1824	1183	1930	820	80	1788	1788	1892	1489	2057	1153	1763	1762	1861	1473	2021	1139
	85	1890	1889	1925	1790	2067	1426	1864	1863	1895	1774	2032	1409	90	1991	1991	1993	1992	2097	1719	1966	1966	1965	1964	2062	1702
58000	75	1750	1613	1873	1227	1975	829	1721	1597	1840	1210	1934	827	80	1821	1821	1911	1538	2072	1184	1795	1794	1880	1522	2006	1147
	85	1926	1925	1949	1863	2086	1469	1898	1898	1919	1847	2051	1452	90	2030	2029	2031	2031	2119	1786	2002	2001	2003	2002	2084	1769
	75	1750	1613	1873	1227	1975	829	1721	1597	1840	1210	1934	827	80	1821	1821	1911	1538	2072	1184	1795	1794	1880	1522	2006	1147
	85	1926	1925	1949	1863	2086	1469	1898	1898	1919	1847	2051	1452	90	2030	2029	2031	2031	2119	1786	2002	2001	2003	2002	2084	1769

Table 52. Gross cooling capacities – 162 tons evaporative condensing – high capacity evaporator coil, 60Hz

CFM	Ent DB (°F)	Ambient Temperature (°F)																							
		60						65						70											
		Entering Wet Bulb (°F)			61			67			73			Entering Wet Bulb (°F)			61			67			73		
CAP	SHC	CHC	CAP	SHC	CHC	CAP	SHC	CHC	CAP	SHC	CHC	CAP	SHC	CHC	CAP	SHC	CHC	CAP	SHC	CHC	CAP	SHC	CHC		
21000	75	1535	1065	1700	967	1884	827	1884	827	1884	827	1884	827	1884	827	1884	827	1884	827	1884	827	1884	827	1884	827
	80	1539	1229	1705	1090	1885	948	1885	948	1885	948	1885	948	1885	948	1885	948	1885	948	1885	948	1885	948	1885	948
	85	1544	1353	1709	1213	1890	1070	1890	1070	1890	1070	1890	1070	1890	1070	1890	1070	1890	1070	1890	1070	1890	1070	1890	1070
	90	1548	1476	1707	1331	1894	1192	1894	1192	1894	1192	1894	1192	1894	1192	1894	1192	1894	1192	1894	1192	1894	1192	1894	1192
26000	75	1643	1215	1809	1037	1998	861	1998	861	1998	861	1998	861	1998	861	1998	861	1998	861	1998	861	1998	861	1998	861
	80	1649	1367	1820	1190	2004	1012	2004	1012	2004	1012	2004	1012	2004	1012	2004	1012	2004	1012	2004	1012	2004	1012	2004	1012
	85	1654	1512	1901	1382	2011	1161	2011	1161	2011	1161	2011	1161	2011	1161	2011	1161	2011	1161	2011	1161	2011	1161	2011	1161
	90	1659	1657	1832	1490	2018	1310	2018	1310	2018	1310	2018	1310	2018	1310	2018	1310	2018	1310	2018	1310	2018	1310	2018	1310
31000	75	1723	1314	1895	1101	2078	885	2078	885	2078	885	2078	885	2078	885	2078	885	2078	885	2078	885	2078	885	2078	885
	80	1727	1486	1905	1280	2089	1064	2089	1064	2089	1064	2089	1064	2089	1064	2089	1064	2089	1064	2089	1064	2089	1064	2089	1064
	85	1746	1663	2003	1507	2101	1243	2101	1243	2101	1243	2101	1243	2101	1243	2101	1243	2101	1243	2101	1243	2101	1243	2101	1243
	90	1764	1764	1917	1629	2211	1468	2211	1468	2211	1468	2211	1468	2211	1468	2211	1468	2211	1468	2211	1468	2211	1468	2211	1468
36000	75	1776	1399	1958	1158	2134	903	2134	903	2134	903	2134	903	2134	903	2134	903	2134	903	2134	903	2134	903	2134	903
	80	1795	1601	1970	1364	2155	1113	2155	1113	2155	1113	2155	1113	2155	1113	2155	1113	2155	1113	2155	1113	2155	1113	2155	1113
	85	1825	1810	1972	1563	2169	1319	2169	1319	2169	1319	2169	1319	2169	1319	2169	1319	2169	1319	2169	1319	2169	1319	2169	1319
	90	1908	1908	1991	1763	2178	1521	2178	1521	2178	1521	2178	1521	2178	1521	2178	1521	2178	1521	2178	1521	2178	1521	2178	1521
41000	75	1827	1481	2008	1211	2174	918	2174	918	2174	918	2174	918	2174	918	2174	918	2174	918	2174	918	2174	918	2174	918
	80	1852	1712	2020	1444	2206	1159	2206	1159	2206	1159	2206	1159	2206	1159	2206	1159	2206	1159	2206	1159	2206	1159	2206	1159
	85	1904	1904	2028	1664	2221	1392	2221	1392	2221	1392	2221	1392	2221	1392	2221	1392	2221	1392	2221	1392	2221	1392	2221	1392
	90	1956	1956	2053	1892	2231	1621	2231	1621	2231	1621	2231	1621	2231	1621	2231	1621	2231	1621	2231	1621	2231	1621	2231	1621
46000	75	1870	1559	2047	1261	2203	930	2203	930	2203	930	2203	930	2203	930	2203	930	2203	930	2203	930	2203	930	2203	930
	80	1901	1820	2051	1510	2247	1203	2247	1203	2247	1203	2247	1203	2247	1203	2247	1203	2247	1203	2247	1203	2247	1203	2247	1203
	85	1977	1977	2076	1763	2264	1462	2264	1462	2264	1462	2264	1462	2264	1462	2264	1462	2264	1462	2264	1462	2264	1462	2264	1462
	90	2054	2054	2107	2020	2265	1705	2265	1705	2265	1705	2265	1705	2265	1705	2265	1705	2265	1705	2265	1705	2265	1705	2265	1705
51000	75	1906	1632	2079	1309	2223	940	2223	940	2223	940	2223	940	2223	940	2223	940	2223	940	2223	940	2223	940	2223	940
	80	1946	1926	2087	1577	2280	1245	2280	1245	2280	1245	2280	1245	2280	1245	2280	1245	2280	1245	2280	1245	2280	1245	2280	1245
	85	2041	2041	2116	1859	2282	1520	2282	1520	2282	1520	2282	1520	2282	1520	2282	1520	2282	1520	2282	1520	2282	1520	2282	1520
	90	2136	2136	2158	2146	2308	1794	2308	1794	2308	1794	2308	1794	2308	1794	2308	1794	2308	1794	2308	1794	2308	1794	2308	1794
54000	75	1925	1676	2073	1328	2232	946	2232	946	2232	946	2232	946	2232	946	2232	946	2232	946	2232	946	2232	946	2232	946
	80	1970	1970	2106	1616	2297	1269	2297	1269	2297	1269	2297	1269	2297	1269	2297	1269	2297	1269	2297	1269	2297	1269	2297	1269
	85	2075	2075	2138	1916	2301	1555	2301	1555	2301	1555	2301	1555	2301	1555	2301	1555	2301	1555	2301	1555	2301	1555	2301	1555
	90	2185	2185	2184	2184	2329	1846	2329	1846	2329	1846	2329	1846	2329	1846	2329	1846	2329	1846	2329	1846	2329	1846	2329	1846
58000	75	1948	1733	2094	1358	2241	953	2241	953	2241	953	2241	953	2241	953	2241	953	2241	953	2241	953	2241	953	2241	953
	80	2005	2005	2129	1667	2316	1301	2316	1301	2316	1301	2316	1301	2316	1301	2316	1301	2316	1301	2316	1301	2316	1301	2316	1301
	85	2117	2117	2164	1991	2324	1600	2324	1600	2324	1600	2324	1600	2324	1600	2324	1600	2324	1600	2324	1600	2324	1600	2324	1600
	90	2228	2228	2229	2229	2355	1915	2355	1915	2355	1915	2355	1915	2355	1915	2355	1915	2355	1915	2355	1915	2355	1915	2355	1915



Performance Data

Table 52. Gross cooling capacities – 162 tons evaporative condensing – high capacity evaporator coil, 60Hz
(continued)

CFM	Ent DB (°F)	Ambient Temperature (°F)																								
		75						80																		
		Entering Wet Bulb (°F)			73			Entering Wet Bulb (°F)																		
		61	SHC	CAP	SHC	CAP	SHC	61	SHC	CAP	SHC	67	SHC	CAP	SHC	73										
21000	75	1476	1068	1634	929	1810	788	1455	1056	1611	917	1785	778	80	1480	1191	1640	1052	1812	909	1460	1179	1617	1039	1787	898
	85	1485	1314	1645	1174	1818	1032	1463	1301	1621	1161	1793	1020	80	1489	1437	1649	1296	1898	1329	1466	1423	1626	1283	1857	1171
26000	75	1577	1175	1739	998	1915	820	1554	1162	1713	985	1886	809	80	1610	1341	1747	1150	1923	970	1560	1309	1721	1136	1894	957
	85	1589	1470	1754	1300	1931	1121	1566	1456	1728	1286	1904	1108	80	1568	1568	1760	1449	1939	1269	1573	1573	1733	1434	1987	1293
31000	75	1651	1272	1816	1059	1987	842	1626	1258	1788	1046	1955	832	80	1656	1442	1826	1239	2002	1023	1631	1427	1799	1225	1973	1009
	85	1676	1619	1907	1451	2014	1201	1652	1605	1806	1401	1984	1187	80	1696	1696	1840	1584	2023	1376	1672	1672	1893	1605	2085	1408
36000	75	1700	1354	1874	1115	2037	859	1673	1338	1845	1101	2002	849	80	1720	1555	1886	1321	2064	1071	1733	1557	1857	1307	2031	1057
	85	1754	1754	1887	1516	2078	1277	1730	1730	1860	1501	2045	1262	80	1789	1789	1909	1716	2088	1479	1727	1727	1881	1701	2056	1464
41000	75	1748	1434	1920	1168	2071	872	1720	1417	1889	1153	2033	864	80	1774	1665	1933	1401	2111	1117	1747	1649	1903	1386	2076	1101
	85	1835	1834	1943	1617	2127	1348	1811	1810	1913	1601	2092	1333	80	1896	1896	1968	1845	2137	1577	1875	1875	1939	1829	2158	1576
46000	75	1788	1511	1956	1217	2095	883	1759	1494	1924	1202	2055	876	80	1821	1771	1961	1461	2148	1160	1793	1755	1930	1445	2112	1144
	85	1904	1904	1987	1714	2165	1418	1879	1878	1956	1698	2130	1403	80	2005	2004	2021	1972	2168	1657	1964	1964	1991	1956	2137	1641
51000	75	1821	1585	1962	1254	2110	897	1792	1569	1929	1237	2069	886	80	1865	1865	1995	1527	2178	1201	1837	1837	1963	1510	2141	1186
	85	1964	1964	2026	1809	2181	1471	1937	1937	1993	1792	2145	1453	80	2063	2062	2072	2072	2209	1745	2038	2037	2040	2040	2173	1728
54000	75	1839	1629	1978	1276	2117	908	1810	1612	1944	1259	2075	892	80	1890	1890	2013	1566	2193	1225	1864	1863	1980	1548	2155	1209
	85	1997	1997	2046	1866	2199	1505	1969	1968	2013	1848	2162	1487	80	2104	2104	2103	2103	2229	1797	2074	2073	2075	2075	2192	1779
58000	75	1861	1687	1997	1306	2124	916	1831	1670	1962	1288	2081	900	80	1926	1926	2035	1616	2211	1256	1899	1898	2001	1598	2172	1241
	85	2036	2036	2072	1940	2221	1549	2007	2006	2038	1922	2183	1531	80	2145	2145	2146	2145	2253	1865	2117	2116	2116	2116	2217	1847

Supply Fan (with or without Variable Frequency Drive)

Figure 25. Supply fan performance LOW CFM – 90 tons air-cooled/100 tons evap-condensing (25")

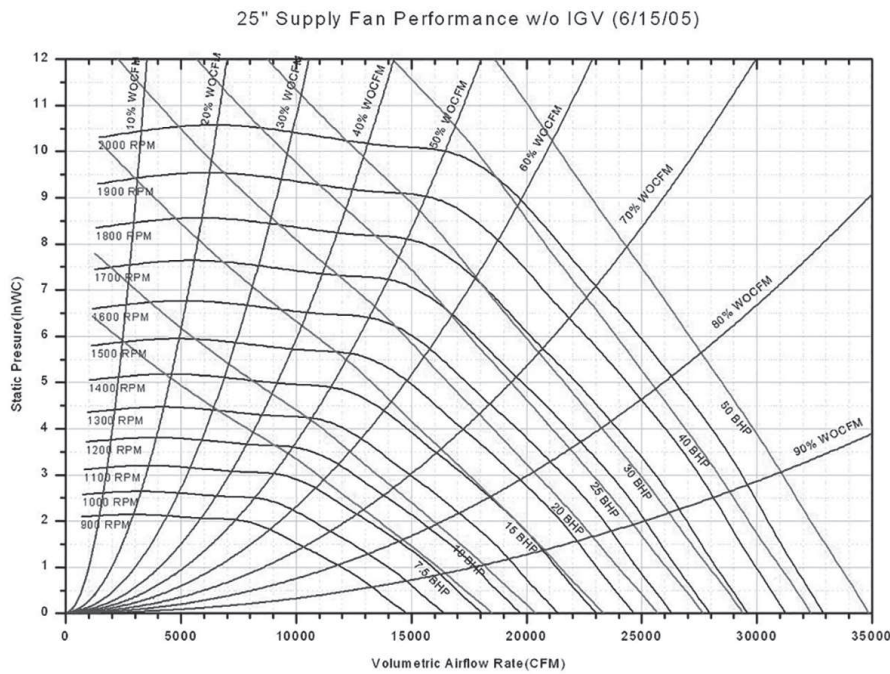
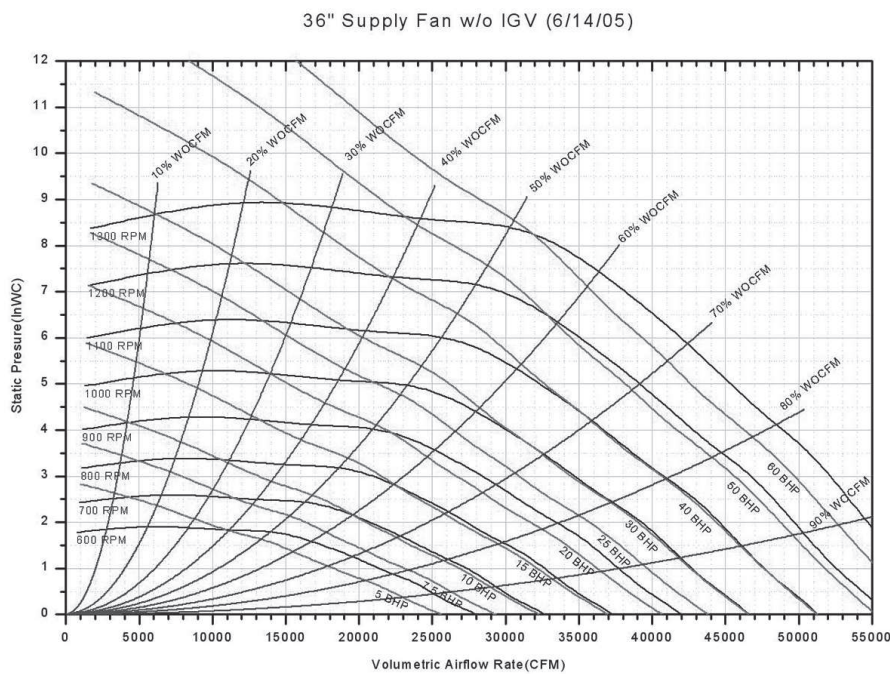

Figure 26. Supply fan performance STANDARD CFM – 90-105 tons air-cool/100-118 tons evap-condensing (36")





Performance Data

Figure 27. Supply fan performance LOW CFM—105-150 tons air-cool/118-162 tons evap-condensing (32")

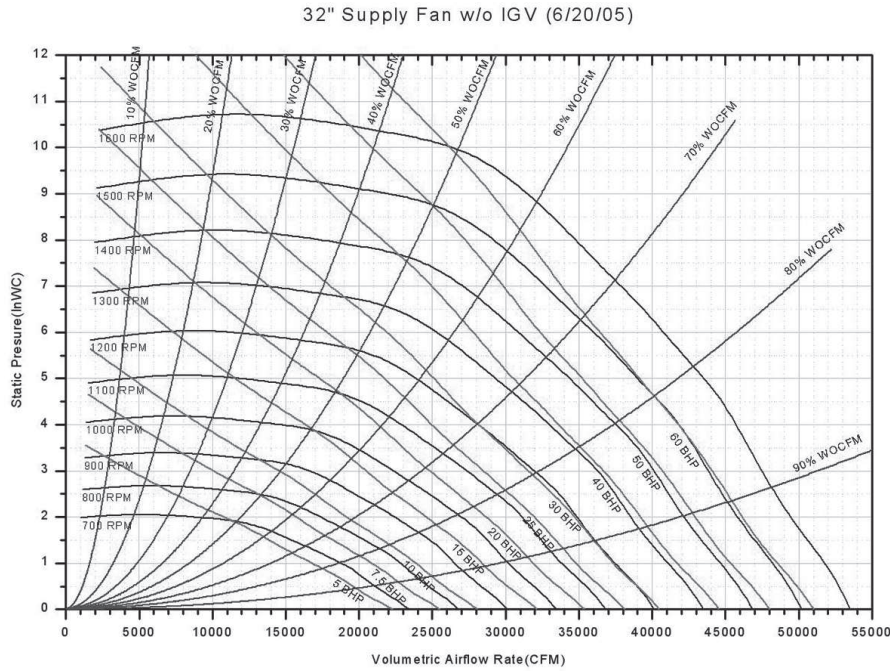
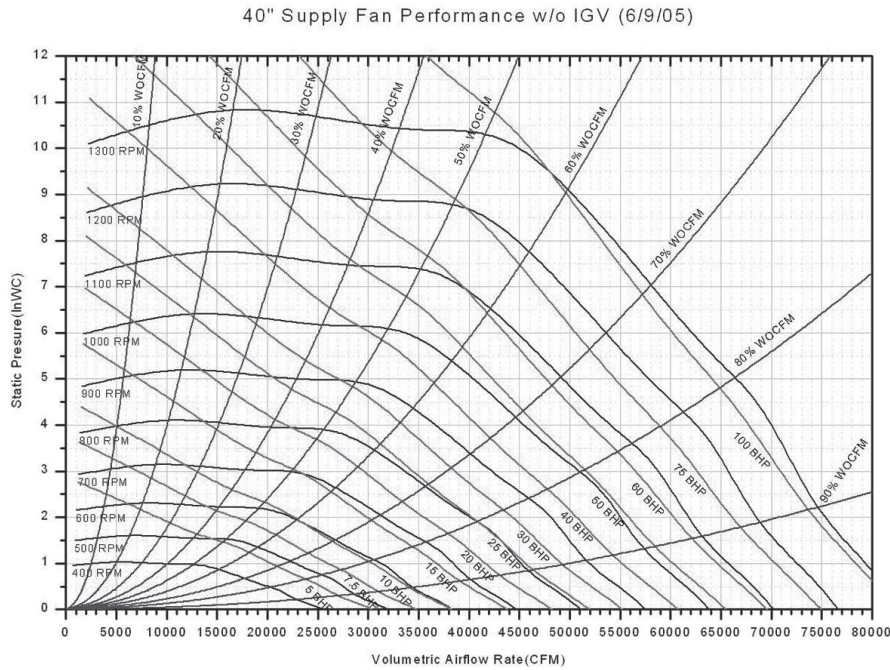

Figure 28. Supply fan performance STANDARD CFM – 120-150 tons air-cool/128-162 tons evap-condensing (40")



Exhaust Fan (with or without Energy Recovery Wheel)

Figure 29. Exhaust fan performance LOW CFM—90 tons air-cooled/100 tons evap-condensing (25" Fan)

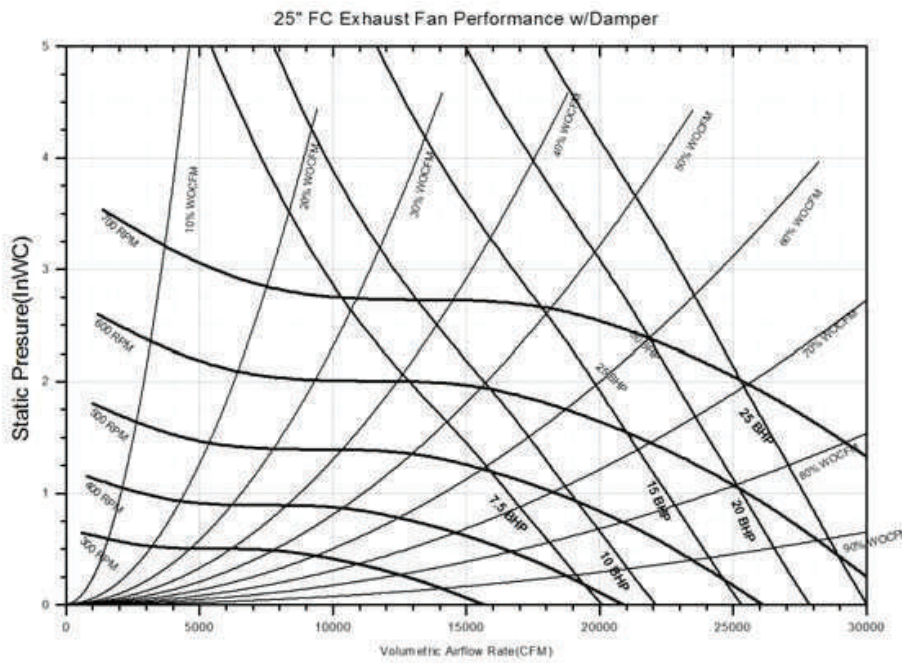

Figure 30. Exhaust fan performance STANDARD CFM—90 tons air-cooled; LOW CFM—105-150 tons air-cooled; STANDARD CFM—100 tons evap-condenser—LOW CFM—118-162 tons evap-condensing (28")

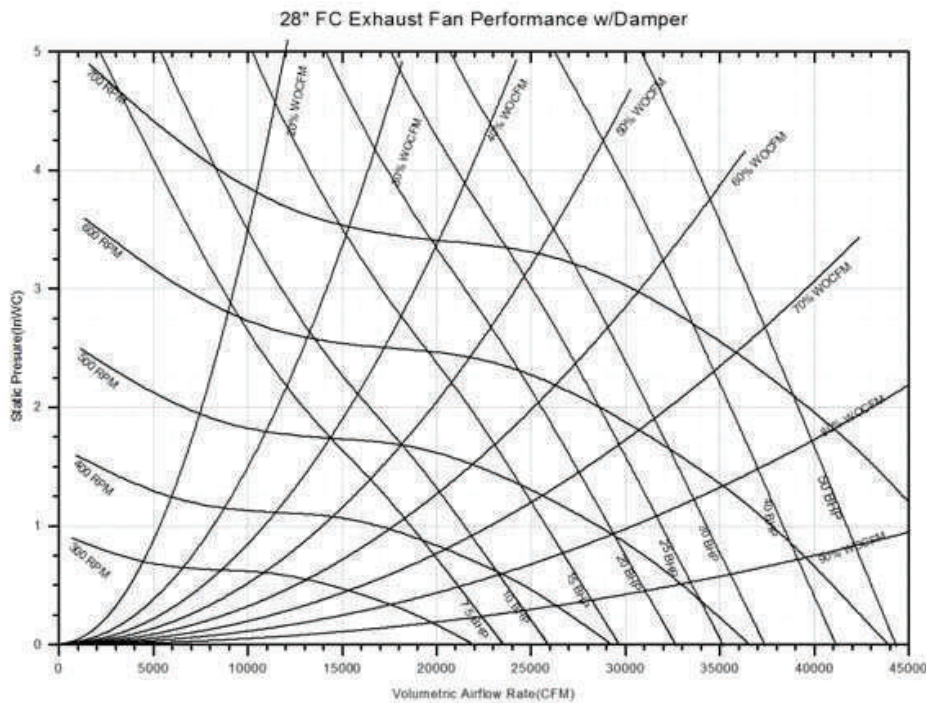
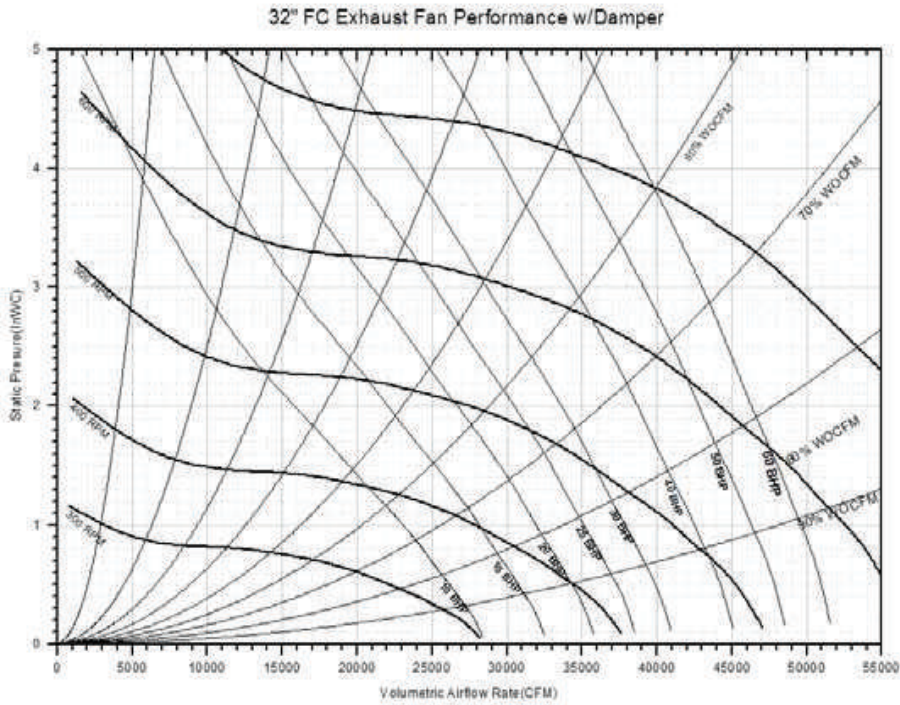

Figure 31. Exhaust fan performance standard CFM — 105-150 tons air-cool/118-162 tons evap-condensing (32")



Return Fan (with or without Energy Recovery Wheel)

Figure 32. Return fan performance LOW CFM — 90-150 tons air-cooled/100-162 tons evap-condensing (36.5")

36.5" Return Fan Performance w/ Damper (6/21/05)

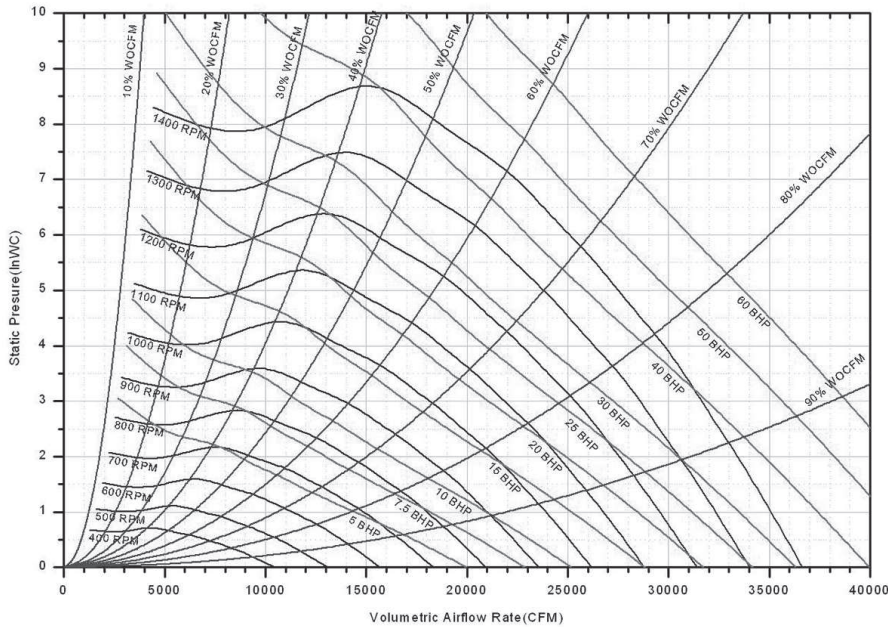

Figure 33. Return fan performance STANDARD CFM – 90-105 tons air-cool/100-118 tons evap-condensing (40")

40" Return Fan Performance w/ Damper (6/21/05)

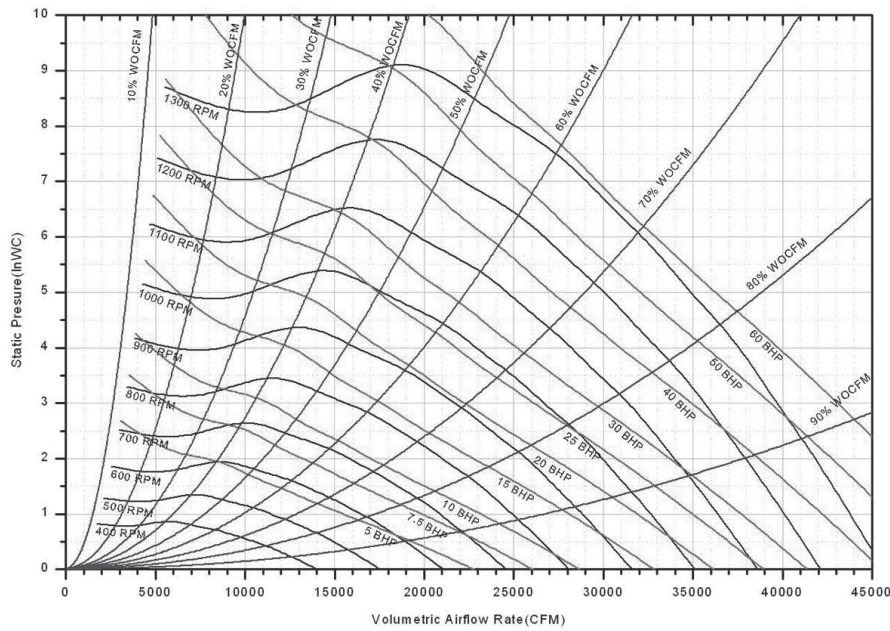
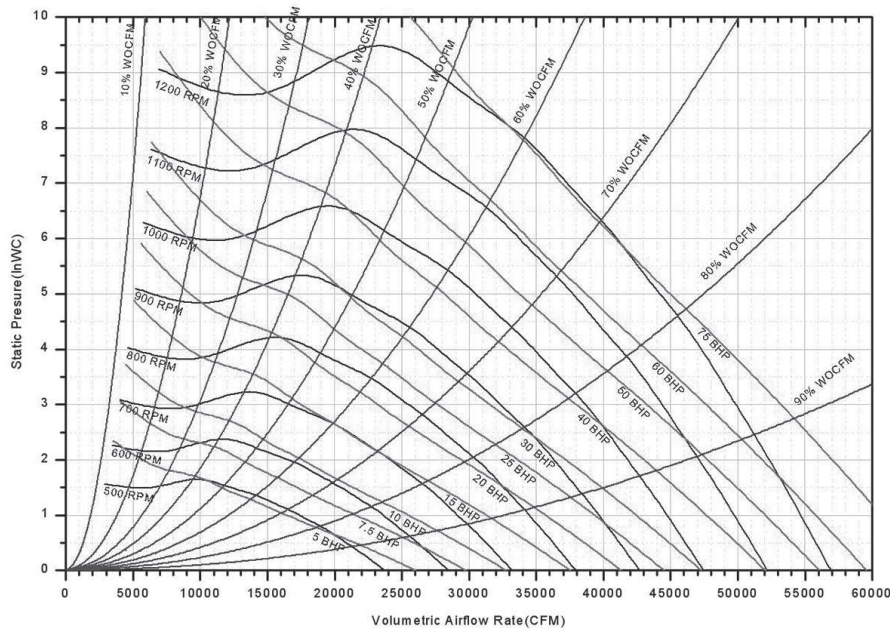

Figure 34. Return fan performance STANDARD CFM – 120-150 tons air-cool/128-162 tons evap-condensing (44")

44" Return Fan Performance w/ Damper (6/21/05)





Performance Data

Heating Capacities

Table 53. Natural gas heating capacities — air-cooled and evaporative condensing

Air Temperature Rise vs. Unit CFM															
Nom Tons (AC/EC)	Gas Heat Modules	Heat Input (MBh)	Heat Output (MBh)	CFM											
				18000	20000	22000	24000	26000	30000	34000	38000	42000	46000	54000	58000
90/100	LOW	850	680	34.8	31.3	28.5	26.1	24.1	20.9	18.4	16.5	14.9	13.6	11.6	10.8
	MEDIUM	1100	880	-	40.6	36.9	33.8	31.2	27	23.9	21.3	19.3	17.6	15	14
	HIGH	1800	1440	-	-	-	55.3	51	44.2	39	34.9	31.6	28.9	24.6	22.9
105/118	LOW	850	680	34.8	31.3	28.5	26.1	24.1	20.9	18.4	16.5	14.9	13.6	11.6	10.8
	MEDIUM	1100	880	-	40.6	36.9	33.8	31.2	27	23.9	21.3	19.3	17.6	15	14
	HIGH	1800	1440	-	-	-	55.3	51	44.2	39	34.9	31.6	28.9	24.6	22.9
120/128	LOW	1100	880	-	-	-	33.8	31.2	27	23.9	21.3	19.3	17.6	15	14
	MEDIUM	1800	1440	-	-	-	-	51	44.2	39	34.9	31.6	28.9	24.6	22.9
	HIGH	2500	2000	-	-	-	-	-	61.4	54.2	48.5	43.9	40.1	34.1	31.8
130-162	LOW	1100	880	-	-	-	33.8	31.2	27	23.9	21.3	19.3	17.6	15	14
	MEDIUM	1800	1440	-	-	-	-	51	44.2	39	34.9	31.6	28.9	24.6	22.9
	HIGH	2500	2000	-	-	-	-	-	61.4	54.2	48.5	43.9	40.1	34.1	31.8

Notes:

- Actual limits may be + or - the values shown; to accurately calculate capacities, contact the local Trane Sales Office or utilize TOPSS.
- Follow the supply CFM ranges posted in the General Data for each case size.
- All heaters are 80% efficient.
- CFM values below the minimum and above the maximum shown in this table are not cULus approved.
- Air temperature rise (at sea level) = heat output (Btu) ÷ (CFM × 1.085).

Table 54. Electric heat air temperature rise (60 Hz) — air-cooled and evaporative-condensing

Nominal Tons (AC/EC)	KW Input (60 Hz)	Total (MBh)	CFM									
			20000	22000	26000	30000	34000	38000	42000	46000	54000	58000
90/100	90	307.2	14.2	12.9	10.9	9.4	8.3	7.5	6.7	—	—	—
	265	904.4	—	37.9	32.1	27.8	24.5	21.9	19.8	—	—	—
105/118	90	307.2	14.2	12.9	10.9	9.4	8.3	7.5	6.7	—	—	—
	265	904.4	41.6	37.9	32.1	27.8	24.5	21.9	19.8	—	—	—
120/162	140	477.8	—	20	16.9	14.7	13	11.6	10.5	9.6	8.2	7.6
	300	1023.9	—	42.9	36.3	31.5	27.8	24.8	22.5	20.5	17.5	16.3

Notes:

- Actual limits may be + or - the values shown; to accurately calculate capacities, contact the local Trane Sales Office or utilize TOPSS.
- Follow the supply CFM ranges posted in the General Data for each case size.

Table 55. Electric heat air temperature rise (50 Hz) — air-cooled and evaporative-condensing

Nominal Tons (AC/EC)	KW Input (50 Hz)	Total (MBh)	CFM									
			20000	22000	26000	30000	34000	38000	42000	46000	54000	58000
90/100	56	191.1	8.8	8	6.8	5.9	5.2	4.6	4.2	—	—	—
	166	566.6	—	23.7	20.1	17.4	15.4	13.7	12.4	—	—	—
105/118	56	191.1	8.8	8	6.8	5.9	5.2	4.6	4.2	—	—	—
	166	566.6	26.1	23.7	20.1	17.4	15.4	13.7	12.4	—	—	—
120/162	88	300.3	—	12.6	10.6	9.2	8.1	7.3	6.6	6	5.3	4.8
	188	641.6	—	26.9	22.7	19.7	17.4	15.6	14.1	12.9	11.4	10.2

Notes:

- Actual limits may be + or - the values shown; to accurately calculate capacities, contact the local Trane Sales Office or utilize TOPSS.
- Follow the supply CFM ranges posted in the General Data for each case size.

Table 56. Electric heat kW ranges — air-cooled and evaporative-condensing

Nominal Tons (AC/EC)	Nominal Voltage		
	460	575	380
90/100	90-265	90-265	56-166
105/118	90-265	90-265	56-166
120/128	140-300	140-300	88-188
130-162	140-300	140-300	88-188

Notes:

- Actual limits may be + or - the values shown; to accurately calculate capacities, contact the local Trane Sales Office or utilize TOPSS.
- Follow the supply CFM ranges posted in the General Data for each case size.

Table 57. Hot water coil heating capacities (Q/ITD) — air-cooled and evaporative-condensing

Nom Tons (AC/EC)	Air-flow (CFM)	Water Flow (GPM)	High Capacity					Low Capacity				
			40	80	120	160	200	30	60	100	140	175
			WPD (ft.)	0.3	1	2.1	3.7	5.6	0.2	0.6	1.5	2.8
90/100	16000		7.57	9.02	9.59	9.9	10.1	5.5	6.54	7.05	7.29	7.42
	20000		8.26	10.08	10.84	11.25	11.52	6.02	7.34	8.01	8.33	8.5
	25000		8.9	11.15	12.12	12.66	13.01	6.52	8.15	9	9.42	9.65
	30000		9.4	12.02	13.18	13.84	14.27	6.91	8.81	9.84	10.35	10.62
	33000		9.65	12.46	13.74	14.47	14.94	7.11	9.15	10.28	10.84	11.14
	36000		9.86	12.86	14.25	15.04	15.56	7.28	9.46	10.68	11.29	11.63
	40000		10.12	13.35	14.86	15.73	16.31	7.48	9.83	11.16	11.84	12.21
105/118	19000		8.1	9.83	10.55	10.94	11.18	5.9	7.15	7.78	8.09	8.25
	23000		8.67	10.75	11.64	12.13	12.44	6.34	7.85	8.63	9.01	9.21
	28000		9.21	11.69	12.78	13.39	13.79	6.77	8.56	9.52	9.99	10.25
	33000		9.65	12.46	13.74	14.47	14.94	7.11	9.15	10.28	10.84	11.14
	38000		10	13.11	14.56	15.4	15.94	7.38	9.65	10.93	11.58	11.93
	43000		10.29	13.67	15.28	16.21	16.83	7.61	10.08	11.5	12.22	12.62
	45000		10.39	13.87	15.54	16.51	17.15	7.69	10.23	11.71	12.46	12.88
120/128	21000		9.19	11.27	12.12	12.58	12.88	6.67	8.17	8.93	9.29	9.48
	26000		9.89	12.46	13.55	14.16	14.55	7.21	9.07	10.04	10.51	10.76
	31000		0	13.43	14.75	15.5	15.98	7.64	9.81	10.98	11.55	11.86
	36000		0	14.24	15.78	16.66	17.22	0	10.43	11.78	12.46	12.83
	41000		0	14.94	16.67	17.67	18.32	0	10.96	12.49	13.27	13.69
	46000		0	15.54	17.45	18.57	19.3	0	11.42	13.12	13.99	14.46
	51000		0	16.06	18.15	19.37	20.18	0	11.83	13.68	14.63	15.15
	54000		0	16.35	18.53	19.82	20.67	0	12.05	13.98	14.99	15.54
130/140	23000		9.49	11.77	12.73	13.25	13.58	6.91	8.55	9.39	9.8	10.01
	26000		9.89	12.46	13.55	14.16	14.55	7.21	9.07	10.04	10.51	10.76
	30000		10.33	13.25	14.53	15.25	15.71	7.56	9.67	10.8	11.35	11.65
	35000		0	14.09	15.59	16.44	16.99	0	10.31	11.63	12.29	12.64
	40000		0	14.81	16.5	17.48	18.11	0	10.86	12.36	13.11	13.52
	45000		0	15.42	17.3	18.4	19.11	0	11.34	13	13.85	14.31
	50000		0	15.96	18.02	19.22	20.01	0	11.75	13.57	14.51	15.02
	55000		0	16.44	18.65	19.96	20.82	0	12.12	14.08	15.1	15.67
	58000		0	16.7	19	20.37	21.28	0	12.32	14.37	15.44	16.03



Performance Data

Table 57. Hot water coil heating capacities (Q/ITD) — air-cooled and evaporative-condensing (continued)

Nom Tons (AC/EC)	Air-flow (CFM)	Water Flow (GPM)	High Capacity					Low Capacity				
			40	80	120	160	200	30	60	100	140	175
			WPD (ft.)	0.3	1	2.1	3.7	5.6	0.2	0.6	1.5	2.8
150/162	23000		9.49	11.77	12.73	13.25	13.58	6.91	8.55	9.39	9.8	10.01
	26000		9.89	12.46	13.55	14.16	14.55	7.21	9.07	10.04	10.51	10.76
	30000		10.33	13.25	14.53	15.25	15.71	7.56	9.67	10.8	11.35	11.65
	35000		0	14.09	15.59	16.44	16.99	0	10.31	11.63	12.29	12.64
	40000		0	14.81	16.5	17.48	18.11	0	10.86	12.36	13.11	13.52
	45000		0	15.42	17.3	18.4	19.11	0	11.34	13	13.85	14.31
	50000		0	15.96	18.02	19.22	20.01	0	11.75	13.57	14.51	15.02
	55000		0	16.44	18.65	19.96	20.82	0	12.12	14.08	15.1	15.67
58000		0	16.7	19	20.37	21.28	0	12.32	14.37	15.44	16.03	

Notes:

1. Nominal capacity is in tons
2. WPD is waterside pressure drop in feet of water
3. Hot water capacity is at 180°F entering water temperature and 65°F entering air temperature
4. Maximum entering water temperature is 200°F.

Table 58. Steam coil heating capacities (Q/ITD) — air-cooled and evaporative-condensing

Nominal Tons (AC/EC)	Airflow	High Cap	Low Cap
90/100	16000	7.33	4.99
	20000	8.17	5.67
	25000	9.06	6.35
	30000	9.84	6.91
	33000	10.26	7.19
	36000	10.66	7.44
	40000	11.16	7.74
105/118	19000	7.97	5.51
	23000	8.73	6.1
	28000	9.55	6.71
	33000	10.27	7.2
	38000	10.92	7.61
	43000	11.52	7.95
120/128	45000	11.74	8.07
	21000	9.4	6.43
	26000	10.41	7.24
	31000	11.29	7.92
	36000	12.08	8.49
	41000	12.8	8.97
	46000	13.45	9.39
	51000	14.06	9.75
54000	14.4	9.95	

Table 58. Steam coil heating capacities (Q/ITD) – air-cooled and evaporative-condensing (continued)

Nominal Tons (AC/EC)	Airflow	High Cap	Low Cap
130/140	23000	9.82	6.78
	26000	10.41	7.24
	30000	11.12	7.79
	35000	11.93	8.38
	40000	12.66	8.88
	45000	13.32	9.31
	50000	13.94	9.68
	55000	14.52	10.01
150/162	23000	9.82	6.78
	26000	10.41	7.24
	30000	11.12	7.79
	35000	11.93	8.38
	40000	12.66	8.88
	45000	13.32	9.31
	50000	13.94	9.68
	55000	14.52	10.01
	58000	14.84	10.18

Notes:

1. Nominal capacity is in tons.
2. Steam coil capacity is at 15 psig and 65°F entering air temperature.
3. Capacities are expressed as mbh (Q) per degree (°F) of initial temperature difference (ITD) between the entering steam temperature (°F) and the entering (return) air temperature (°F) to the coil.
4. The maximum recommended steam pressure is 35 psig.

Table 59. Properties of steam

Steam Pressure (psig)	2	5	10	15	20	25	30	40	50
Temperature of Steam (°F)	219	227	239	250	259	267	274	287	298



Performance Data

Component Static Pressure Drops

Table 60. Component static pressure drops (in. H₂O) — air-cooled and evaporative condensing

Nom Tons AC/EC	CFM	Evaporator Coil					(Dampers wide open)			
		Standard		High Capacity		Reheat Coil	Return Damper	Outside Air ^(a)		
		Dry	Wet	Dry	Wet	Dry		Econo Damper	Traq Damper	
90/100	16000	0.1	0.13	0.17	0.22	0.04	0.06	0.11	0.19	
	20000	0.15	0.19	0.24	0.31	0.06	0.1	0.17	0.29	
	25000	0.21	0.27	0.35	0.45	0.08	0.16	0.27	0.45	
	30000	0.28	0.36	0.47	0.6	0.11	0.23	0.39	0.65	
	33000	0.33	0.42	0.55	0.7	0.13	0.28	0.47	0.79	
	36000	0.38	0.48	0.63	0.8	0.15	0.34	0.57	0.94	
	40000	0.45	0.57	0.75	0.95	0.18	0.42	0.7	1.16	
105/118	19000	0.18	0.23	0.27	0.32	0.05	0.09	0.15	0.26	
	23000	0.2	0.31	0.37	0.47	0.07	0.13	0.23	0.38	
	28000	0.34	0.43	0.51	0.64	0.1	0.2	0.34	0.57	
	33000	0.44	0.56	0.66	0.84	0.13	0.28	0.47	0.79	
	38000	0.55	0.7	0.83	1.05	0.16	0.38	0.63	1.05	
	43000	0.67	0.85	1.01	1.28	0.2	0.49	0.81	1.34	
	45000	0.73	0.92	1.09	1.38	0.21	0.53	0.89	1.47	
120/128	21000	0.09	0.12	0.18	0.23	0.04	0.05	0.1	0.17	
	26000	0.13	0.16	0.25	0.32	0.06	0.09	0.15	0.26	
	31000	0.17	0.21	0.34	0.43	0.08	0.12	0.22	0.36	
	36000	0.21	0.27	0.43	0.55	0.1	0.17	0.3	0.49	
	41000	0.26	0.34	0.53	0.67	0.12	0.22	0.39	0.64	
	46000	0.32	0.4	0.64	0.81	0.15	0.28	0.49	0.8	
	51000	0.38	0.48	0.75	0.95	0.18	0.35	0.61	0.99	
	54000	0.41	0.52	0.83	1.05	0.2	0.39	0.68	1.11	
130/140	23000	0.14	0.18	0.21	0.27	0.05	0.07	0.12	0.2	
	26000	0.17	0.22	0.25	0.32	0.06	0.09	0.15	0.26	
	30000	0.21	0.27	0.32	0.41	0.07	0.12	0.21	0.34	
	35000	0.27	0.35	0.41	0.52	0.1	0.16	0.28	0.46	
	40000	0.34	0.43	0.51	0.65	0.12	0.21	0.37	0.61	
	45000	0.41	0.52	0.61	0.78	0.15	0.27	0.47	0.77	
	50000	0.49	0.62	0.73	0.93	0.17	0.33	0.59	0.95	
	55000	0.57	0.72	0.85	1.08	0.2	0.4	0.71	1.15	
	58000	0.62	0.78	0.93	1.18	0.22	0.45	0.79	1.28	
150/162	23000	0.21	0.27	-	-	0.05	0.07	0.12	0.2	
	26000	0.25	0.32	-	-	0.06	0.09	0.15	0.26	
	30000	0.32	0.41	-	-	0.07	0.12	0.21	0.34	
	35000	0.41	0.52	-	-	0.1	0.16	0.28	0.46	
	40000	0.51	0.65	-	-	0.12	0.21	0.37	0.61	
	45000	0.61	0.78	-	-	0.15	0.27	0.47	0.77	
	50000	0.73	0.93	-	-	0.17	0.33	0.59	0.95	
	55000	0.85	1.08	-	-	0.2	0.4	0.71	1.15	
	58000	0.93	1.18	-	-	0.22	0.45	0.79	1.28	

Note: Actual Supply Fan CFM Range: 90/100 Ton 16000-40000; 105/118 Ton 19000-45000; 120/128 Ton 21000-54000; 130-150/140-162 Ton 23000-58000

^(a) Use only 1 value. Select Traq value if option is selected.

Table 61. Component static pressure drops (in. H₂O) — air-cooled and evaporative condensing — heating

Nom Tons AC/EC	CFM	Electric Heating (Hz) All kW's	Gas Heating						Hydronic Heating Coil Data			
			Low Heat		Medium Heat		High Heat		Hot Water Coil		Steam Coil	
			DF	Hz	DF	Hz	DF	Hz	High	Low	High	Low
90/100	16000	0.01	0.01	0.1	0.01	0.12	0.01	0.14	0.13	0.08	0.12	0.08
	20000	0.02	0.01	0.16	0.01	0.19	0.01	0.22	0.19	0.12	0.17	0.12
	25000	0.03	0.01	0.24	0.01	0.3	0.01	0.35	0.27	0.17	0.26	0.18
	30000	0.05	0.02	0.35	0.02	0.44	0.02	0.5	0.36	0.24	0.35	0.25
	33000	0.06	0.02	0.42	0.02	0.53	0.02	0.61	0.42	0.28	0.41	0.3
	36000	0.07	0.03	0.51	0.03	0.63	0.03	0.72	0.49	0.33	0.48	0.35
	40000	0.08	0.03	0.62	0.03	0.77	0.03	0.89	0.58	0.39	0.57	0.43
105/118	19000	0.02	0.01	0.14	0.01	0.17	0.01	0.2	0.17	0.11	0.16	0.11
	23000	0.03	0.01	0.21	0.01	0.26	0.01	0.3	0.23	0.15	0.22	0.16
	28000	0.04	0.02	0.31	0.02	0.38	0.02	0.44	0.32	0.21	0.31	0.22
	33000	0.06	0.02	0.42	0.02	0.53	0.02	0.61	0.42	0.28	0.41	0.3
	38000	0.07	0.03	0.56	0.03	0.7	0.03	0.81	0.53	0.36	0.52	0.39
	43000	0.1	0.04	0.72	0.04	0.89	0.04	1.03	0.65	0.45	0.65	0.49
	45000	0.1	0.04	0.79	0.04	0.98	0.04	1.13	0.71	0.49	0.7	0.53
120/128	21000	0.02	0	0.16	0	0.19	0	0.23	0.14	0.09	0.13	0.09
	26000	0.03	0	0.25	0	0.3	0	0.35	0.2	0.13	0.19	0.13
	31000	0.05	0	0.35	0	0.42	0	0.49	0.26	0.17	0.25	0.18
	36000	0.07	0	0.48	0	0.57	0	0.67	0.33	0.22	0.33	0.24
	41000	0.09	0	0.62	0	0.74	0	0.86	0.42	0.28	0.41	0.3
	46000	0.11	0	0.78	0	0.93	0	1.09	0.5	0.34	0.5	0.37
	51000	0.13	0	0.96	0	1.15	0	1.34	0.6	0.41	0.59	0.44
	54000	0.15	0	1.07	0	1.28	0.01	1.5	0.66	0.45	0.65	0.49
130/140	23000	0.03	0	0.2	0	0.23	0.01	0.27	0.16	0.1	0.15	0.1
	26000	0.03	0	0.25	0	0.3	0	0.35	0.2	0.13	0.19	0.13
	30000	0.05	0	0.33	0	0.4	0	0.46	0.25	0.16	0.24	0.17
	35000	0.06	0	0.45	0	0.54	0	0.63	0.32	0.21	0.31	0.22
	40000	0.08	0	0.59	0	0.7	0	0.82	0.4	0.27	0.39	0.28
	45000	0.1	0	0.75	0	0.89	0	1.04	0.49	0.33	0.48	0.35
	50000	0.13	0	0.92	0	1.1	0	1.29	0.58	0.39	0.57	0.43
	55000	0.16	0	1.12	0.01	1.33	0.01	1.56	0.68	0.47	0.67	0.51
	58000	0.17	0.01	1.24	0.01	1.48	0.01	1.74	0.75	0.51	0.74	0.56
150/162	23000	0.03	0	0.2	0	0.23	0.01	0.27	0.16	0.1	0.15	0.1
	26000	0.03	0	0.25	0	0.3	0	0.35	0.2	0.13	0.19	0.13
	30000	0.05	0	0.33	0	0.4	0	0.46	0.25	0.16	0.24	0.17
	35000	0.06	0	0.45	0	0.54	0	0.63	0.32	0.21	0.31	0.22
	40000	0.08	0	0.59	0	0.7	0	0.82	0.4	0.27	0.39	0.28
	45000	0.1	0	0.75	0	0.89	0	1.04	0.49	0.33	0.48	0.35
	50000	0.13	0	0.92	0	1.1	0	1.29	0.58	0.39	0.57	0.43
	55000	0.16	0	1.12	0.01	1.33	0.01	1.56	0.68	0.47	0.67	0.51
	58000	0.17	0.01	1.24	0.01	1.48	0.01	1.74	0.75	0.51	0.74	0.56

Note: There is no pressure drop with electric heat DF configuration



Performance Data

Table 62. Component static pressure drops (in. H₂O) – air-cooled and evaporative condensing – filters

Nom Tons AC/EC	CFM	Standard Filter Section (Pre Evap)					Final Filter Section (Post Evap)					
		Std 2" High Eff Throw Away Filters	90-95% Low PD Cartridge Filters w/ 2" Prefilter	90-95% Low PD Cartridge Filters w/ 4" Prefilter	90-95% Cartridge Filters w/ 2" Prefilter (a)	90-95% Bag Filters w/ 2" Prefilter (a)	90-95% Std Temp Low PD Cartridge Filters w/4" Prefilter (b)	90-95% Std Temp Bag Filters w/ 2" Prefilter (c)	90-95% Std Temp Cartridge Filters w/ 2" Prefilter (c)	90-95% Hi Temp Cartridge Filters w/ 2" Hi Temp Prefilter (c)	90-95% Hi Temp HEPA w/ 2" Hi Temp Prefilter (d)	90-95% Std Temp HEPA Filters w/ 2" Hi Temp Prefilter (d)
90/100	16000	0.08	0.24	—	0.27	0.34	0.23	0.36	0.29	0.35	0.54	0.48
	20000	0.11	0.31	—	0.33	0.41	0.31	0.43	0.36	0.44	0.69	0.61
	25000	0.15	0.42	—	0.42	0.5	0.43	0.54	0.47	0.58	0.89	0.78
	30000	0.2	0.53	—	0.54	0.6	0.56	0.65	0.6	0.74	1.1	0.95
	33000	0.23	0.61	—	0.61	0.67	0.65	0.73	0.69	0.86	1.22	1.06
	36000	0.26	0.69	—	0.7	0.73	0.74	0.8	0.79	0.98	1.36	1.16
	40000	0.3	0.8	—	0.82	0.83	0.88	0.91	0.93	1.15	—	—
105/118	19000	0.1	0.27	—	0.3	0.37	0.27	0.4	0.32	0.4	0.62	0.55
	23000	0.11	0.29	—	0.32	0.39	0.29	0.42	0.34	0.42	0.66	0.58
	28000	0.18	0.49	—	0.49	0.56	0.51	0.61	0.54	0.68	1.01	0.88
	33000	0.23	0.61	—	0.61	0.67	0.65	0.73	0.69	0.86	1.22	1.06
	38000	0.28	0.74	—	0.76	0.78	0.81	0.86	0.86	1.06	—	—
	43000	0.33	0.89	—	0.92	0.91	0.98	1	1.05	1.3	—	—
	45000	0.36	0.95	—	0.99	0.96	1.05	1.06	1.13	1.4	—	—
120/128	21000	0.1	—	0.3	0.35	0.42	0.34	0.45	0.38	0.47	0.73	0.64
	26000	0.13	—	0.41	0.44	0.52	0.46	0.56	0.49	0.61	0.93	0.81
	31000	0.17	—	0.53	0.56	0.62	0.59	0.68	0.63	0.78	1.14	0.99
	36000	0.2	—	0.66	0.7	0.73	0.74	0.8	0.79	0.98	1.36	1.16
	41000	0.25	—	0.81	0.85	0.86	0.91	0.94	0.97	1.2	—	—
	46000	0.29	—	0.96	1.03	0.99	1.09	1.09	1.17	1.45	—	—
	51000	0.34	—	1.14	—	—	1.29	—	—	—	—	—
54000	0.37	—	1.25	—	—	1.42	—	—	—	—	—	
130/140	23000	0.1	—	0.32	0.37	0.44	0.36	0.47	0.4	0.49	0.77	0.68
	26000	0.14	—	0.43	0.47	0.54	0.48	0.58	0.52	0.64	0.97	0.85
	30000	0.17	—	0.55	0.59	0.64	0.62	0.7	0.66	0.82	1.18	1.02
	35000	0.21	—	0.69	0.73	0.76	0.78	0.83	0.82	1.02	1.4	1.2
	40000	0.26	—	0.84	0.89	0.88	0.94	0.97	1.01	1.25	—	—
	45000	0.3	—	1	1.07	1.02	1.13	1.12	1.22	1.51	—	—
	50000	0.35	—	1.17	1.27	1.16	1.33	—	—	—	—	—
	55000	0.41	—	1.36	—	—	1.55	—	—	—	—	—
58000	0.44	—	1.48	—	—	—	—	—	—	—	—	
150/162	23000	0.1	—	0.32	0.37	0.44	0.36	0.47	0.4	0.49	0.77	0.68
	26000	0.14	—	0.43	0.47	0.54	0.48	0.58	0.52	0.64	0.97	0.85
	30000	0.17	—	0.55	0.59	0.64	0.62	0.7	0.66	0.82	1.18	1.02
	35000	0.21	—	0.69	0.73	0.76	0.78	0.83	0.82	1.02	1.4	1.2
	40000	0.26	—	0.84	0.89	0.88	0.94	0.97	1.01	1.25	—	—
	45000	0.3	—	1	1.07	1.02	1.13	1.12	1.22	1.51	—	—
	50000	0.35	—	1.17	1.27	1.16	1.33	—	—	—	—	—
	55000	0.41	—	1.36	—	—	1.55	—	—	—	—	—
58000	0.44	—	1.48	—	—	—	—	—	—	—	—	

(a) 120-150/128-162 Ton Max CFM 50000
 (b) 130-150/140-162 Ton Max CFM 55500
 (c) 120-150/128-162 Ton Max CFM 46250
 (d) 90-150/100-162 Ton Max CFM 37000

Table 63. Energy recovery wheel component static pressure drops — air-cooled and evaporative condensing — low CFM

Nom Tons AC/EC	CFM	Outside Air Bypass Damper Open	Outside Air Bypass Damper Closed	Exhaust Air Bypass Damper Open	Exhaust Air Bypass Damper Closed
Low CFM Energy Recovery Wheel					
90/100	8000	0.07	0.78	0.09	0.66
	9000	0.09	0.88	0.11	0.79
	10000	0.12	0.99	0.14	0.92
	12000	0.16	1.20	0.19	1.16
	14000	0.21	1.42	0.24	1.41
	16000	0.27	—	0.29	—
	20000	0.40	—	0.42	—
	25000	0.59	—	0.60	—
	30000	0.80	—	0.80	—
	33000	0.94	—	0.94	—
	36000	1.08	—	1.07	—
40000	1.30	—	1.27	—	
105/118	9000	0.09	0.88	0.11	0.79
	12000	0.16	1.20	0.19	1.16
	14000	0.21	1.42	0.24	1.41
	16000	0.27	—	0.29	—
	19000	0.36	—	0.39	—
	23000	0.51	—	0.52	—
	28000	0.71	—	0.72	—
	33000	0.94	—	0.94	—
	38000	1.19	—	1.18	—
	43000	1.46	—	1.41	—
	45000	1.58	—	1.52	—
120/128	9000	0.09	0.78	0.11	0.69
	12000	0.16	1.06	0.18	1.02
	15000	0.23	1.36	0.26	1.36
	18000	0.31	—	0.34	—
	21000	0.41	—	0.44	—
	26000	0.59	—	0.62	—
	31000	0.79	—	0.82	—
	36000	1.01	—	1.04	—
	41000	1.25	—	1.28	—
	46000	1.51	—	1.52	—
	51000	1.79	—	1.79	—
54000	1.96	—	1.95	—	
130/140	9000	0.09	0.71	0.10	0.62
	12000	0.15	0.97	0.18	0.92
	16000	0.25	1.34	0.28	1.33
	20000	0.36	—	0.40	—
	23000	0.46	—	0.49	—
	26000	0.57	—	0.60	—
	30000	0.72	—	0.75	—
	35000	0.93	—	0.97	—
	40000	1.16	—	1.20	—
	45000	1.40	—	1.43	—
	50000	1.67	—	1.69	—
55000	1.95	—	1.96	—	
58000	2.12	—	2.12	—	



Performance Data

Table 63. Energy recovery wheel component static pressure drops – air-cooled and evaporative condensing – low CFM (continued)

Nom Tons AC/EC	CFM	Outside Air Bypass Damper Open	Outside Air Bypass Damper Closed	Exhaust Air Bypass Damper Open	Exhaust Air Bypass Damper Closed
Low CFM Energy Recovery Wheel					
150/162	9000	0.09	0.71	0.10	0.62
	12000	0.15	0.97	0.18	0.92
	16000	0.25	1.34	0.28	1.33
	20000	0.36	—	0.40	—
	23000	0.46	—	0.49	—
	26000	0.57	—	0.60	—
	30000	0.72	—	0.75	—
	35000	0.93	—	0.97	—
	40000	1.16	—	1.20	—
	45000	1.40	—	1.43	—
	50000	1.67	—	1.69	—
	55000	1.95	—	1.96	—
	58000	2.12	—	2.12	—

Table 64. Energy recovery wheel component static pressure drops – air-cooled and evaporative condensing – standard CFM

Nom Tons AC/EC	CFM	Outside Air Bypass Damper Open	Outside Air Bypass Damper Closed	Exhaust Air Bypass Damper Open	Exhaust Air Bypass Damper Closed
Standard CFM Energy Recovery Wheel					
90/100	8000	0.06	0.54	0.07	0.44
	9000	0.08	0.61	0.10	0.53
	10000	0.10	0.68	0.12	0.62
	12000	0.15	0.83	0.17	0.77
	14000	0.19	0.99	0.22	0.94
	16000	0.24	1.16	0.26	1.12
	18000	0.30	1.32	0.31	1.29
	20000	0.35	-	0.37	-
	25000	0.52	-	0.54	-
	30000	0.70	-	0.73	-
	33000	0.82	-	0.84	-
	36000	0.95	-	0.97	-
	40000	1.12	-	1.14	-
105/118	9000	0.08	0.57	0.09	0.47
	12000	0.14	0.77	0.16	0.65
	14000	0.19	0.93	0.21	0.78
	16000	0.24	1.08	0.26	0.91
	19000	0.32	1.33	0.34	1.11
	21000	0.37	1.49	0.40	1.25
	23000	0.44	-	0.46	-
	28000	0.61	-	0.64	-
	33000	0.80	-	0.82	-
	38000	1.00	-	1.03	-
	43000	1.23	-	1.25	-
	45000	1.33	-	1.34	-

Table 64. Energy recovery wheel component static pressure drops — air-cooled and evaporative condensing — standard CFM (continued)

Nom Tons AC/EC	CFM	Outside Air Bypass Damper Open	Outside Air Bypass Damper Closed	Exhaust Air Bypass Damper Open	Exhaust Air Bypass Damper Closed
Standard CFM Energy Recovery Wheel					
120/128	10000	0.10	0.56	0.11	0.50
	12000	0.14	0.69	0.16	0.63
	15000	0.20	0.89	0.23	0.85
	18000	0.27	1.10	0.29	1.05
	21000	0.35	1.33	0.38	1.28
	24000	0.43	1.57	0.47	1.51
	26000	0.50	-	0.54	-
	31000	0.66	-	0.72	-
	36000	0.84	-	0.91	-
	41000	1.04	-	1.11	-
	46000	1.26	-	1.34	-
	51000	1.49	-	1.56	-
	54000	1.63	-	1.71	-
130-162	13000	0.16	0.59	0.17	0.53
	15000	0.20	0.69	0.22	0.63
	18000	0.26	0.86	0.28	0.79
	21000	0.33	1.04	0.36	0.96
	23000	0.38	1.16	0.42	1.06
	26000	0.45	1.36	0.50	1.24
	29000	0.54	1.57	0.60	1.42
	30000	0.57	-	0.63	-
	35000	0.72	-	0.80	-
	40000	0.89	-	0.98	-
	45000	1.08	-	1.17	-
	50000	1.28	-	1.38	-
	55000	1.50	-	1.60	-
58000	1.63	-	1.74	-	

Table 65. Energy recovery wheel component static pressure drops — air-cooled and evaporative condensing — dampers

Tons AC/EC	CFM	Return Damper, ERW only	Econo Damper, ERW only
90/100	16000	0.14	0.15
	20000	0.2	0.24
	25000	0.29	0.39
	30000	0.42	0.56
	33000	0.51	0.69
	36000	0.61	0.82
	40000	0.75	1.01
105/118	19000	0.19	0.22
	23000	0.25	0.33
	28000	0.37	0.49
	33000	0.51	0.69
	38000	0.68	0.91
	43000	0.87	1.17
	45000	0.96	1.29



Performance Data

Table 65. Energy recovery wheel component static pressure drops — air-cooled and evaporative condensing — dampers (continued)

Tons AC/EC	CFM	Return Damper, ERW only	Econo Damper, ERW only
120/128	21000	0.22	0.18
	26000	0.32	0.27
	31000	0.45	0.39
	36000	0.61	0.53
	41000	0.79	0.69
	46000	1	0.87
	51000	1.24	1.07
130/140 150/162	54000	1.4	1.2
	23000	0.25	0.21
	26000	0.32	0.27
	30000	0.42	0.36
	35000	0.57	0.5
	40000	0.75	0.65
	45000	0.96	0.83
	50000	1.19	1.02
	55000	1.45	1.24
	58000	1.63	1.38

Table 66. Energy recovery wheel pressure loss ΔP (in. wg) and total effectiveness

Actual Airflow CFM	90-118 Tons Low		120/128 Tons Low		130-162 Tons Low		90/100 Tons Standard		105/118 Tons Standard		120/128 Tons Standard		130-162 Tons Standard	
	ΔP	Eff	ΔP	Eff	ΔP	Eff	ΔP	Eff	ΔP	Eff	ΔP	Eff	ΔP	Eff
8000	0.73	77.50	0.64	79.00	0.58	80.00	0.49	81.60	—	—	—	—	—	—
9000	0.82	75.90	0.72	77.60	0.65	78.70	0.55	80.60	0.51	81.30	—	—	—	—
10000	0.91	74.30	0.80	76.20	0.73	77.50	0.61	79.50	0.56	80.30	0.49	81.60	—	—
11000	1.00	72.70	0.88	74.80	0.80	76.20	0.67	78.50	0.62	79.40	0.54	80.70	—	—
12000	1.09	71.10	0.96	73.40	0.87	75.00	0.73	77.40	0.67	78.40	0.59	79.80	—	—
13000	1.18	69.50	1.04	72.00	0.94	73.70	0.79	76.40	0.73	77.40	0.64	79.00	0.48	74.70
14000	—	—	1.12	70.60	1.02	72.40	0.85	75.30	0.79	76.50	0.69	78.10	0.51	72.90
15000	—	—	1.20	69.20	1.09	71.10	0.91	74.30	0.84	75.50	0.74	77.30	0.55	71.90
16000	—	—	—	—	1.16	69.80	0.97	73.20	0.90	74.50	0.79	76.40	0.58	71.00
17000	—	—	—	—	1.24	68.50	1.03	72.10	0.95	73.50	0.83	75.60	0.61	70.00
18000	—	—	—	—	—	—	1.09	71.10	1.01	72.50	0.88	74.70	0.64	69.00
19000	—	—	—	—	—	—	1.15	70.00	1.07	71.50	0.93	73.90	0.67	68.10
20000	—	—	—	—	—	—	1.22	68.90	1.12	70.50	0.98	73.00	0.71	67.10
21000	—	—	—	—	—	—	—	—	1.18	69.50	1.03	72.10	0.74	66.10
22000	—	—	—	—	—	—	—	—	1.23	68.50	1.08	71.30	0.77	65.10
23000	—	—	—	—	—	—	—	—	—	—	1.13	70.40	0.80	64.20
24000	—	—	—	—	—	—	—	—	—	—	1.18	69.50	0.84	63.20
25000	—	—	—	—	—	—	—	—	—	—	1.23	68.70	0.87	62.20
26000	—	—	—	—	—	—	—	—	—	—	—	—	0.90	61.20
27000	—	—	—	—	—	—	—	—	—	—	—	—	0.93	60.30
28000	—	—	—	—	—	—	—	—	—	—	—	—	0.97	59.30
29000	—	—	—	—	—	—	—	—	—	—	—	—	1.00	58.30

Fan Drive Selections

Table 67. Supply air fan drive selections — air-cooled (AC) and evaporative condensing (EC)

Nom Tons AC/EC	Low/Std	rpm	Horse Power (hp)								
			15 hp	20 hp	25 hp	30 hp	40 hp	50 hp	60 hp	75 hp	100 hp
			Drive/No.								
90/100	Low	2000							L		
	Low	1900						K			
	Low	1800						J			
	Low	1700				H					
	Low	1600			G						
	Low	1500		F							
	Low	1400	E	E							
90-105 AC, 100-118 EC	Std	1300							D	D	
	Std	1200							C	C	
	Std	1100						B	B		
	Std	1000				A	A				
	Std	900		9	9	9					
	Std	800	8	8	8						
105-150 AC 118-162 EC	Low	1500							F		
	Low	1400						E	E		
	Low	1300					D	D			
	Low	1200				C	C				
	Low	1100			B	B					
	Low	1000		A	A						
	Low	900	9	9							
120-150 AC, 128-162 EC	Std	1200									C
	Std	1100							B	B	B
	Std	1000						A	A	A	A
	Std	900					9	9	9	9	
	Std	800			8	8	8	8			
	Std	700		7	7	7	7				

Table 68. Exhaust air fan drive selections — air-cooled (AC) and evaporative condensing (EC)

Nom Tons AC/EC	Low/Std	rpm	Horse Power (hp)								
			15 hp	20 hp	25 hp	30 hp	40 hp	50 hp	60 hp	75 hp	100 hp
			Drive/No.								
90 AC, 100 EC	Low	700				7	7				
	Low	600	6	6	6	6	6				
	Low	500	5	5	5	5					
	Low	400	4	4	4						
	Std	600				6	6				
	Std	500			5	5	5				
	Std	400		4	4	4	4				
	Std	300		3	3						
105-150 AC, 118-162 EC	Low	600				6	6	6	6	6	
	Low	500			5	5	5	5	5	5	
	Low	400	4	4	4	4	4	4	4		
	Low	300	3	3	3						
	Std	600								6	6
	Std	500			5	5	5	5	5		
	Std	400			4	4	4				



Performance Data

Table 69. Return air fan drive selections air-cooled (AC) and evaporative condensing (EC)

		Horse Power (hp)								
Nom Tons AC/EC	Low/Std	rpm	7.5 hp	10 hp	15 hp	20 hp	25 hp	30 hp	40 hp	50 hp
			Drive/No.							
All	Low	1400							E	
	Low	1300						D		
	Low	1200					C	C		
	Low	1100				B				
	Low	1000			A	A				
	Low	900			9					
	Low	800	8	8						
	Low	700	7							
90-105 AC, 100-118 EC	Std	1200							C	
	Std	1100						B	B	
	Std	1000					A	A		
	Std	900				9				
	Std	800			8					
	Std	700		7						
120-150 AC/ 128-162 EC	Std	1100								B
	Std	1000							A	A
	Std	900						9	9	
	Std	800				8	8			
	Std	700			7					
	Std	600			6					



Electrical Data

Electrical Service Sizing

To correctly size electrical service wiring for a unit, find the appropriate calculations listed below. Each type of unit has its own set of calculations for MCA (Minimum Circuit Ampacity), MOP (Maximum Overcurrent Protection), and RDE (Recommended Dual Element fuse size). Read the load definitions that follow and then find the appropriate set of calculations based on unit type.

Note: Set 1 is for cooling only and cooling with gas heat units, and set 2 is for cooling with electric heat units.

Load Definitions: (To determine load values, see the Electrical Service Sizing Data Tables on the following page.)

LOAD1 = Current of the largest motor (compressor or fan motor)

LOAD2 = Sum of the currents of all remaining motors

LOAD3 = Current of electric heaters

LOAD4 = Any other load rated at 1 AMP or more

Set 1: Cooling Only Rooftop Units and Cooling with Gas Heat Rooftop Units

$$\text{MCA} = (1.25 \times \text{LOAD1}) + \text{LOAD2} + \text{LOAD4}$$

$$\text{MOP} = (2.25 \times \text{LOAD1}) + \text{LOAD2} + \text{LOAD4}$$

Select a fuse rating equal to the MOP value. If the MOP value does not equal a standard fuse size as listed in NEC 240-6, select the next lower standard fuse rating.

Note: If selected MOP is less than the MCA, then select the lowest standard maximum fuse size which is equal to or larger than the MCA, provided the selected fuse size does not exceed 800 amps.

$$\text{RDE} = (1.5 \times \text{LOAD1}) + \text{LOAD2} + \text{LOAD4}$$

Select a fuse rating equal to the RDE value. If the RDE value does not equal a standard fuse size as listed in NEC 240-6, select the next higher standard fuse rating.

Note: If the selected RDE is greater than the selected MOP value, then select the RDE value to equal the MOP value.

Set 2: Rooftop units with Electric Heat

To arrive at the correct MCA, MOP, and RDE values for these units, two sets of calculations must be performed. First calculate the MCA, MOP, and RDE values as if the unit was in cooling mode (use the equations given in Set 1). Then calculate the MCA, MOP, and RDE values as if the unit were in heating mode as follows. (Keep in mind when determining LOADS that the compressors don't run while the unit is in heating mode).

$$\text{MCA} = 1.25 \times (\text{LOAD1} + \text{LOAD2} + \text{LOAD4}) + \text{LOAD3}$$

The nameplate MCA value will be the larger of the cooling mode MCA value or the heating mode MCA value calculated above.

$$\text{MOP} = (2.25 \times \text{LOAD1}) + \text{LOAD2} + \text{LOAD3} + \text{LOAD4}$$

The selection MOP value will be the larger of the cooling mode MOP value or the heating mode MOP value calculated above.

Select a fuse rating equal to the MOP value. If the MOP value does not equal a standard fuse size as listed in NEC 240-6, select the next lower standard fuse rating.

Note: If selected MOP is less than the MCA, then select the lowest standard maximum fuse size which is equal to or larger than the MCA, provided the selected fuse size does not exceed 800 amps.

$$\text{RDE} = (1.5 \times \text{LOAD1}) + \text{LOAD2} + \text{LOAD3} + \text{LOAD4}$$

The selection RDE value will be the larger of the cooling mode RDE value or the heating mode RDE value calculated above.



Electrical Data

Select a fuse rating equal to the RDE value. If the RDE value does not equal a standard fuse size as listed in NEC 240-6, select the next higher standard fuse rating.

Notes:

- If the selected RDE is greater than the selected MOP value, then select the RDE value to equal the MOP value.
- On 90 to 162 ton rooftops, the selected MOP value is stamped in the MOP field on the unit nameplate.

Service Sizing Data

Table 70. Electrical service sizing data – air-cooled and evaporative condensing

Fixed Capacity Compressors								
Nom Tons AC/EC	Compressor		Nominal Voltage					
	Size	No per Unit	460 V		575 V		380 V	
			RLA (ea.)	LRA (ea.)	RLA (ea.)	LRA (ea.)	RLA (ea.)	LRA (ea.)
90/100	250	4	34.1	215	27.3	175	34	215
105/118	250	2	34.1	215	27.3	175	34	215
	315	2	44.7	260	35.8	210	44.6	260
120/128	315	4	44.7	260	35.8	210	44.6	260
130/140	315	2	44.7	260	35.8	210	44.6	260
	374	2	52.1	320	41.1	235	52	320
150/162	374	4	52.1	320	41.1	235	52	320

Table 71. Electrical service sizing data – eFlex™

Nom Tons AC	Compressor		Nominal Voltage					
	Size	No per Unit	460 V		575 V		380 V	
			RLA (ea.)	LRA (ea.)	RLA (ea.)	LRA (ea.)	RLA (ea.)	LRA (ea.)
90	170 ^(a)	1	42.9	N/A	35.6	N/A	53.5	N/A
	184	4	28	160	21.7	135	34.3	160
105	170	1	42.9	N/A	35.6	N/A	53.5	N/A
	184	3	28	160	21.7	135	34.3	160
	250	1	34.1	215	27.3	175	34	215
120	170	1	42.9	N/A	35.6	N/A	53.5	N/A
	184	2	28	160	21.7	135	34.3	160
	250	1	34.1	215	27.3	175	34	215
	315	1	44.7	260	35.8	210	44.6	260
130	170	1	42.9	N/A	35.6	N/A	53.5	N/A
	184	2	28	160	21.7	135	34.3	160
	315	1	44.7	260	35.8	210	44.6	260
	374	1	52.1	320	41.1	235	52	320
150	170	1	42.9	N/A	35.6	N/A	53.5	N/A
	184	1	28	160	21.7	135	34.3	160
	250	1	34.1	215	27.3	175	34	215
	374	2	52.1	320	41.1	235	52	320

^(a) Variable Speed Compressor

Table 72. Electrical service sizing data—motors — air-cooled and evaporative condensing

Nom Tons	No of Fans	460V	575V	380V
		FLA	FLA	FLA
90-105 (AC)	6	16.2	13.2	15
120, 130, 150 (AC)	8	21.6	17.6	20
100 (EC)	2	11.8	N/A	N/A
118, 128, 140, 162 (EC)	2	11.8	N/A	N/A

Table 73. Electrical service sizing data—supply, exhaust/return fan motors — air-cooled and evaporative condensing

Motor HP	460 V	575 V	380 V
	FLA	FLA	FLA
Supply Fan Motors			
15	18.0	15.0	22.0
20	24.7	19.5	28.0
25	30.5	24.8	34.0
30	36.6	29.0	41.0
40	49.0	39.0	54.0
50	59.0	47.2	68.0
60	71.0	57.0	81.0
75	88.0	70.0	103.0
100	115.0	92.0	N/A
Exhaust/Return Fan Motors			
7.5	9.8	7.8	12.1
10	12.6	10.1	15.2
15	18.0	15.0	22.0
20	24.7	19.5	28.0
25	30.5	24.8	35.0
30	36.6	29.0	41.0
40	49.0	39.0	54.0
50	59.0	47.2	68.0
60	71.0	57.0	81.0

Table 74. Electrical service sizing data—electric heat module (electric heat units only)

Module kW	Voltage		
	460	575	380
	FLA	FLA	FLA
90 / 56	108.3	86.6	85.1
140 / 88	168.4	134.7	133.7
265 / 166	318.8	255	252.2
300 / 188	360.8	288.7	285.6

Table 75. Electrical service sizing data—control power transformer (heating mode only) — air-cooled and evaporative condensing

Nom Tons AC/EC	Digit 2 Unit Function	Voltage		
		460	575	380
		FLA	FLA	FLA
90-150/100-162	E, L, S, X	3	3	4
90, 105/100, 118	F (850 mbh)	4	4	5
	F (1100 mbh)	4	4	5
	F (1800 mbh)	4	4	5
120-150/128-162	F (1100 mbh)	4	4	5
	F (1800 mbh)	4	4	5
	F (2500 mbh)	4	4	5

Table 76. Electrical service sizing data—crankcase heater — air-cooled and evaporative condensing

Nom Tons AC/EC	Voltage		
	460	575	380
	FLA (add)	FLA(add)	FLA(add)
All	1	1	1

Table 77. Voltage utilization range

Unit Voltage	Range
460/60/3	414-506
575/60/3 ^(a)	517-633
380/50/3 ^(a)	342-418

^(a) Units with air-cooled condensers only.

Table 78. Electrical service sizing data—energy recovery wheel motor — air-cooled and evaporative condensing

Nom Tons AC/EC	Unit Function	Voltage	
		460	575
		FLA	FLA
90-120/100-128	1 (Low CFM ERW)	1.2	0.95
130-150/140-162	1 (Low CFM ERW)	1.7	1.4
All	2 (Std. CFM ERW)	1.7	1.4

Table 79. Electrical service sizing data—evaporative condenser

Unit Part	kW	hp	Voltage
			460
			FLA
Pump		1.5	2.7
Sump Heater	3		3.8



Dimensional Data

Figure 35. Unit top/left view

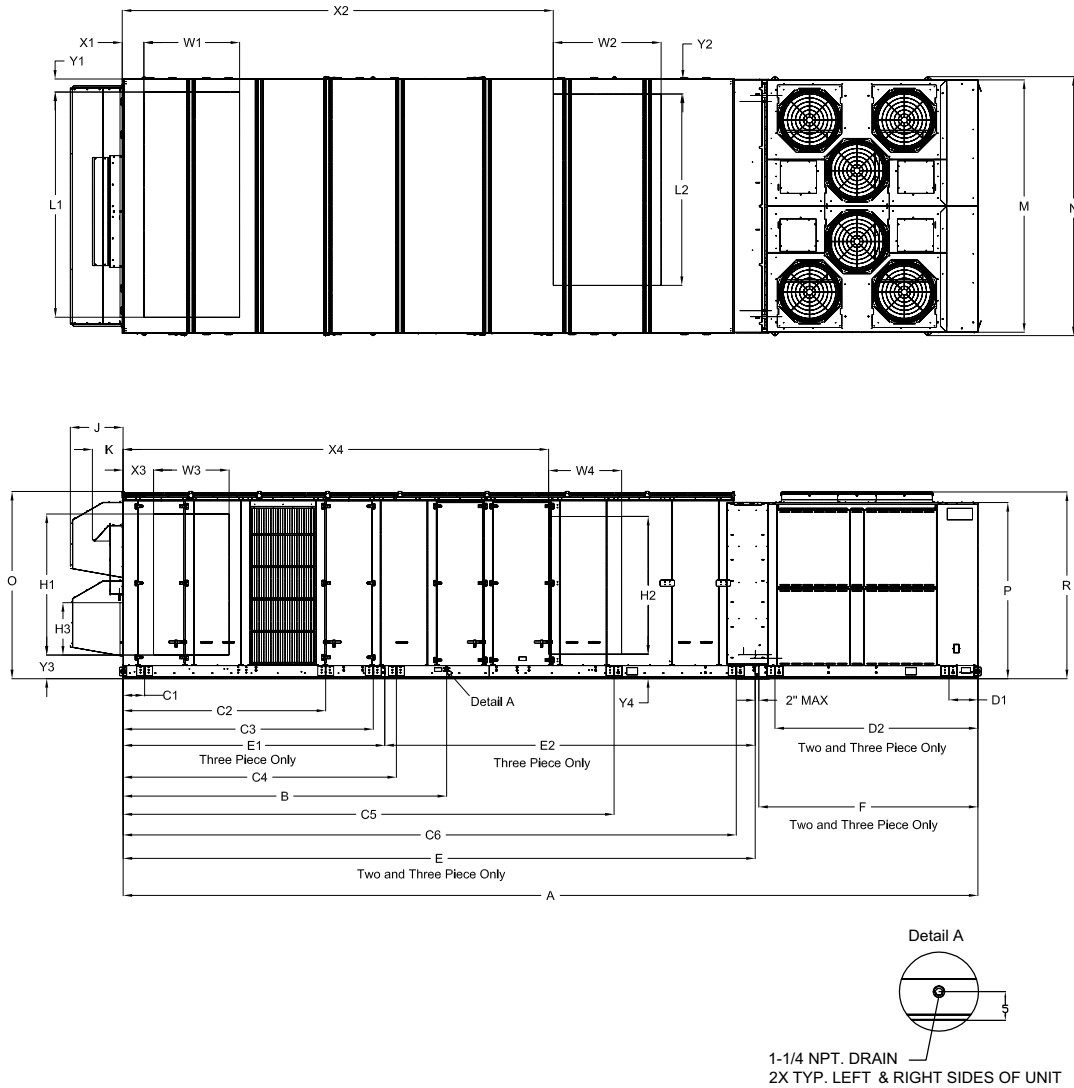

Note: Representative view showing air-cooled condenser fans; for a representative view with evaporative condensing fans, see "Superior Control Options," p. .

Table 80. Unit dimensions (in.)—ONE-PIECE unit air-cooled—WITHOUT energy recovery wheel

Tons	Blank Section	Unit Dimensions		Lifting Lug Locations				Unit Width		Unit Height			Return Fan	Exhaust Fan
		A	B	Air Handler Side			Condenser Side	M	N	O	P	R	J	K
				C1	C2	C3	D1							
90	None	437 3/16	159 15/16	66	252 14/16	N/A	27 11/16	139 13/16	143 8/16	103 12/16	97 9/16	103 7/16	29 3/16	17
	4 ft	485 6/16	159 15/16	66	252 14/16	N/A	54 2/16	139 13/16	143 8/16					
	8 ft	533 9/16	159 15/16	66	252 14/16	N/A	54 2/16	139 13/16	143 8/16					
105	None	455 3/16	159 15/16	66	252 14/16	N/A	27 11/16	139 13/16	143 8/16	103 12/16	97 9/16	103 7/16	29 3/16	17
	4 ft	503 6/16	159 15/16	66	252 14/16	N/A	54 2/16	139 13/16	143 8/16					
	8 ft	551 9/16	159 15/16	66	252 14/16	N/A	54 2/16	139 13/16	143 8/16					



Dimensional Data

Table 80. Unit dimensions (in.)—ONE-PIECE unit air-cooled—WITHOUT energy recovery wheel (continued)

Tons	Blank Section	Unit Dimensions		Lifting Lug Locations				Unit Width		Unit Height			Return Fan	Exhaust Fan
		A	B	Air Handler Side			Condenser Side	M	N	O	P	R	J	K
				C1	C2	C3	D1							
120-150 ^(a)	None	528 15/16	197 1/16	66	269 6/16	N/A	63 2/16	139 13/16	143 8/16	—	—	—	—	—
120-150 ^(a)	4 ft	577 2/16	197 1/16	66	269 6/16	N/A	63 2/16	139 13/16	143 8/16	—	—	—	—	—
120-150 ^(b)	None	540 15/16	197 1/16	66	269 6/16	N/A	63 2/16	139 13/16	143 8/16	—	—	—	—	—

^(a) All units except high heat gas models

^(b) High heat gas models only

Table 81. Unit dimensions (in.)—ONE-PIECE unit air-cooled—WITH energy recovery wheel

Tons	Blank Section	Unit Dimensions		Lifting Lug Locations				Unit Width		Unit Height		
		A	B	Air Handler Side			Condenser Side	M	N	O	P	R
				C1	C2	C3	D1					
90	None	533 9/16	256 5/16	66	201 1/16	349 4/16	27 11/16	139 13/16	143 8/16	103 12/16	97 9/16	103 7/16
90	4 ft	581 13/16	256 5/16	66	201 1/16	349 4/16	54 2/16	139 13/16	143 8/16	103 12/16	97 9/16	103 7/16
105	None	551 9/16	256 5/16	66	201 1/16	349 4/16	27 11/16	139 13/16	143 8/16	103 12/16	97 9/16	103 7/16
105	4 ft	599 13/16	256 5/16	66	201 1/16	349 4/16	54 2/16	139 13/16	143 8/16	103 12/16	97 9/16	103 7/16
Tons	Blank Section	Return Fan	Exhaust Fan									
		J	K									
90	None	N/A	17									
90	4 ft	N/A	17									
105	None	N/A	17									
105	4 ft	N/A	17									

Table 82. Unit dimensions (in.)—TWO-PIECE unit air-cooled—WITHOUT energy recovery wheel

Tons	Blank Section	Unit Dimensions				Lifting Lug Locations				Lug Locations	
		A	B	E	F	Air Handler Side				Condenser Side	
						C1	C2	C3	C4	D1	D2
90	None	454 4/16	159 15/16	330 14/16	121 6/16	66	252 14/16	N/A	N/A	16	112 7/16
	4 ft	502 7/16	159 15/16	379 1/16	121 6/16	66	252 14/16	368 6/16	N/A	16	112 7/16
	8 ft	550 11/16	159 15/16	427 4/16	121 6/16	66	252 14/16	416 10/16	N/A	16	112 7/16
105	None	472 4/16	159 15/16	330 14/16	139 6/16	66	252 14/16	N/A	N/A	16	130 7/16
	4 ft	520 7/16	159 15/16	379 1/16	139 6/16	66	252 14/16	368 6/16	N/A	16	130 7/16
	8 ft	568 11/16	159 15/16	427 4/16	139 6/16	66	252 14/16	416 10/16	N/A	16	130 7/16
120-150 ^(a)	None	546	197 1/16	395 10/16	148 6/16	66	269 6/16	384 15/16	N/A	16	139 7/16
120-150 ^(a)	4 ft	594 4/16	197 1/16	443 13/16	148 6/16	66	269 6/16	433 2/16	N/A	16	139 7/16
120-150 ^(a)	8 ft	642 7/16	197 1/16	492 1/16	148 6/16	66	269 6/16	481 6/16	N/A	16	139 7/16
120-150 ^(a)	None	558	197 1/16	407 10/16	148 6/16	66	269 6/16	396 15/16	N/A	16	139 7/16

Table 82. Unit dimensions (in.)—TWO-PIECE unit air-cooled—WITHOUT energy recovery wheel (continued)

Tons	Blank Section	Unit Width		Unit Height			Return Fan	Exhaust Fan
		M	N	O	P	R	J	K
90	None	139 13/16	143 8/16	103 12/16	97 9/16	103 7/16	29 3/16	17
	4 ft	139 13/16	143 8/16	103 12/16	97 9/16	103 7/16	29 3/16	17
	8 ft	139 13/16	143 8/16	103 12/16	97 9/16	103 7/16	29 3/16	17
105	None	139 13/16	143 8/16	103 12/16	97 9/16	103 7/16	29 3/16	17
	4 ft	139 13/16	143 8/16	103 12/16	97 9/16	103 7/16	29 3/16	17
	8 ft	139 13/16	143 8/16	103 12/16	97 9/16	103 7/16	29 3/16	17
120-150(a)	None	139 13/16	143 8/16	103 12/16	97 9/16	103 7/16	29 3/16	17
120-150(a)	4 ft	139 13/16	143 8/16	103 12/16	97 9/16	103 7/16	29 3/16	17
120-150(a)	8 ft	139 13/16	143 8/16	103 12/16	97 9/16	103 7/16	29 3/16	17
120-150(b)	None	139 13/16	143 8/16	103 12/16	97 9/16	103 7/16	29 3/16	17

(a) High Heat Gas Models Only

(b) High Heat Gas Models Only

Table 83. Unit dimensions (in.)—TWO-PIECE unit air-cooled—WITH energy recovery wheel

Tons	Blank Section	Unit Dimensions				Lifting Lug Locations				Lug Locations	
		A	B	E	F	Air Handler Side				Condenser Side	
						C1	C2	C3	C4	D1	D2
90	None	550 11/16	256 5/16	427 5/16	121 6/16	66	201 1/16	349 4/16	N/A	16	112 7/16
	4 ft	598 14/16	256 5/16	475 8/16	121 6/16	66	201 1/16	349 4/16	464 13/16	16	112 7/16
	8 ft	647 2/16	256 5/16	523 12/16	121 6/16	66	201 1/16	349 4/16	513	16	112 7/16
105	None	568 11/16	256 5/16	427 5/16	139 6/16	66	201 1/16	349 4/16	N/A	16	130 7/16
	4 ft	616 14/16	256 5/16	475 8/16	139 6/16	66	201 1/16	349 4/16	464 13/16	16	130 7/16
	8 ft	665 2/16	256 5/16	523 12/16	139 6/16	66	201 1/16	349 4/16	513	16	130 7/16
120-150(a)	None	642 7/16	293 8/16	492 1/16	148 6/16	66	238 5/16	365 5/16	480 14/16	16	139 7/16
120-150(a)	4 ft	690 10/16	293 8/16	540 4/16	148 6/16	66	238 5/16	365 5/16	529 2/16	16	139 7/16
120-150(a)	8 ft	738 14/16	293 8/16	588 8/16	148 6/16	66	238 5/16	365 5/16	577 5/16	16	139 7/16
120-150(a)	None	654 7/16	293 8/16	504 1/16	148 6/16	66	238 5/16	365 5/16	492 14/16	16	139 7/16

Tons	Blank Section	Unit Width		Unit Height			Return Fan	Exhaust Fan
		M	N	O	P	R	J	K
90	None	139 13/16	143 8/16	103 12/16	97 9/16	103 7/16	N/A	17
	4 ft	139 13/16	143 8/16	103 12/16	97 9/16	103 7/16	N/A	17
	8 ft	139 13/16	143 8/16	103 12/16	97 9/16	103 7/16	N/A	17
105	None	139 13/16	143 8/16	103 12/16	97 9/16	103 7/16	N/A	17
	4 ft	139 13/16	143 8/16	103 12/16	97 9/16	103 7/16	N/A	17
	8 ft	139 13/16	143 8/16	103 12/16	97 9/16	103 7/16	N/A	17
120-150(a)	None	139 13/16	143 8/16	103 12/16	97 9/16	103 7/16	N/A	17
120-150(a)	4 ft	139 13/16	143 8/16	103 12/16	97 9/16	103 7/16	N/A	17
120-150(a)	8 ft	139 13/16	143 8/16	103 12/16	97 9/16	103 7/16	N/A	17
120-150(b)	None	139 13/16	143 8/16	103 12/16	97 9/16	103 7/16	N/A	17

(a) High Heat Gas Models Only

(b) High Heat Gas Models Only



Dimensional Data

Table 84. Unit dimensions (in.)—TWO-PIECE unit evaporative condensing—WITHOUT energy recovery wheel

Tonnage	Blank Section	Unit Dimensions				Lifting Lug Locations				Lug Locations	
		A	B	E	F	Air Handler Side				Condenser Side	
						C1	C2	C3	C4	D1	D2
100-118	None	475 8/16	159 15/16	330 14/16	142 10/16	66	252 14/16	N/A	N/A	16	133 11/16
	4 ft	523 12/16	159 15/16	379 1/16	142 10/16	66	252 14/16	368 6/16	N/A	16	133 11/16
	8 ft	571 15/16	159 15/16	427 5/16	142 10/16	66	252 14/16	416 10/16	N/A	16	133 11/16
128-162 ^(a)	None	540 5/16	197 1/16	395 10/16	142 10/16	66	269 6/16	384 15/16	N/A	16	133 11/16
	4 ft	588 8/16	197 1/16	443 14/16	142 10/16	66	269 6/16	433 2/16	N/A	16	133 11/16
	8 ft	636 11/16	197 1/16	492 1/16	142 10/16	66	269 6/16	481 6/16	N/A	16	133 11/16
128-162 ^(b)	None	552 5/16	197 1/16	407 10/16	142 10/16	66	269 6/16	396 15/16	N/A	—	—
Tonnage	Blank Section	Unit Width		Unit Height			Return Fan	Exhaust Fan			
		M	N	O	P	R	J	K			
100-118	None	139 13/16	143 8/16	103 12/16	97 9/16	102 6/16	29 3/16	17			
	4 ft	139 13/16	143 8/16	103 12/16	97 9/16	102 6/16	29 3/16	17			
	8 ft	139 13/16	143 8/16	103 12/16	97 9/16	102 6/16	29 3/16	17			
128-162 ^(a)	None	139 13/16	143 8/16	103 12/16	97 9/16	102 6/16	29 3/16	17			
	4 ft	139 13/16	143 8/16	103 12/16	97 9/16	102 6/16	29 3/16	17			
	8 ft	139 13/16	143 8/16	103 12/16	97 9/16	102 6/16	29 3/16	17			
128-162 ^(b)	None	—	—	—	—	—	29 3/16	17			

Table 85. Unit dimensions (in.)—TWO-PIECE unit evaporative condensing—WITH energy recovery wheel

Tons	Blank Section	Unit Dimensions				Lifting Lug Locations				Lug Locations	
		A	B	E	F	Air Handler Side				Condenser Side	
						C1	C2	C3	C4	D1	D2
100-118	None	571 15/16	256 5/16	427 5/16	142 10/16	66	201 1/16	349 4/16	N/A	16	133 11/16
	4 ft	620 3/16	256 5/16	475 8/16	142 10/16	66	201 1/16	349 4/16	464 13/16	16	133 11/16
	8 ft	668 6/16	256 5/16	523 12/16	142 10/16	66	201 1/16	349 4/16	513	16	133 11/16
128-162 ^(a)	None	636 11/16	293 8/16	492 1/16	142 10/16	66	238 5/16	365 5/16	480 14/16	16	133 11/16
	4 ft	684 15/16	293 8/16	540 4/16	142 10/16	66	238 5/16	365 5/16	529 2/16	16	133 11/16
	8 ft	733 2/16	293 8/16	588 8/16	142 10/16	66	238 5/16	365 5/16	577 5/16	16	133 11/16
128-162 ^(a)	None	648 11/16	293 8/16	504 1/16	142 10/16	66	238 5/16	365 5/16	492 14/16	16	133 11/16
Tons	Unit Width		Unit Height			Return Fan	Exhaust Fan				
	M	N	O	P	R	J	K				
100-118	139 13/16	143 8/16	103 12/16	97 9/16	102 6/16	N/A	17				
	139 13/16	143 8/16	103 12/16	97 9/16	102 6/16	N/A	17				
	139 13/16	143 8/16	103 12/16	97 9/16	102 6/16	N/A	17				
128-162 ^(a)	139 13/16	143 8/16	103 12/16	97 9/16	102 6/16	N/A	17				
	139 13/16	143 8/16	103 12/16	97 9/16	102 6/16	N/A	17				
	139 13/16	143 8/16	103 12/16	97 9/16	102 6/16	N/A	17				
128-162 ^(b)	139 13/16	143 8/16	103 12/16	97 9/16	102 6/16	N/A	17				

^(a) High Heat Gas Models Only

^(b) High Heat Gas Models Only

Table 86. Unit dimensions (in.)—THREE-PIECE unit air-cooled—WITHOUT energy recovery wheel

Tons	Blank Section	Unit Dimensions						Lifting Lug Locations					
		A	B	E	E1	E2	F	Air Handler Side					
								C1	C2	C3	C4	C5	C6
90	None	473 9/16	179 3/16	350 3/16	144 15/16	205 3/16	121 6/16	11 14/16	N/A	138 9/16	151 6/16	272	339 11/16
	4 ft	521 12/16	179 3/16	398 6/16	144 15/16	253 7/16	121 6/16	11 14/16	N/A	138 9/16	151 6/16	272	387 14/16
	8 ft	569 15/16	179 3/16	446 9/16	144 15/16	301 10/16	121 6/16	11 14/16	N/A	138 9/16	151 6/16	272	436 1/16
105	None	491 9/16	179 3/16	350 3/16	144 15/16	205 3/16	139 6/16	11 14/16	N/A	138 9/16	151 6/16	272	339 11/16
	4 ft	539 12/16	179 3/16	398 6/16	144 15/16	253 7/16	139 6/16	11 14/16	N/A	138 9/16	151 6/16	272	387 14/16
	8 ft	587 15/16	179 3/16	446 9/16	144 15/16	301 10/16	139 6/16	11 14/16	N/A	138 9/16	151 6/16	272	436 1/16
120-150(a)	None	571 8/16	222 9/16	421 2/16	161 2/16	260	148 6/16	11 14/16	N/A	155 2/16	167 5/16	294 14/16	410 10/16
	4 ft	619 11/16	222 9/16	469 5/16	161 2/16	308 4/16	148 6/16	11 14/16	N/A	155 2/16	167 5/16	294 14/16	458 13/16
	8 ft	667 15/16	222 9/16	517 9/16	161 2/16	356 7/16	148 6/16	11 14/16	N/A	155 2/16	167 5/16	294 14/16	507 1/16
120-150(a)	None	583 8/16	222 9/16	433 2/16	161 2/16	272	148 6/16	11 14/16	N/A	155 2/16	167 5/16	294 14/16	422 10/16
Tons	Blank Section	Lug Locations		Unit Width		Unit Height			Return Fan	Exhaust Fan			
		Condenser Side		M	N	O	P	R	J	K			
		D1	D2										
90	None	16	112 7/16	139 13/16	143 8/16	103 12/16	97 9/16	103 7/16	29 3/16	17			
	4 ft	16	112 7/16	139 13/16	143 8/16	103 12/16	97 9/16	103 7/16	29 3/16	17			
	8 ft	16	112 7/16	139 13/16	143 8/16	103 12/16	97 9/16	103 7/16	29 3/16	17			
105	None	16	130 7/16	139 13/16	143 8/16	103 12/16	97 9/16	103 7/16	29 3/16	17			
	4 ft	16	130 7/16	139 13/16	143 8/16	103 12/16	97 9/16	103 7/16	29 3/16	17			
	8 ft	16	130 7/16	139 13/16	143 8/16	103 12/16	97 9/16	103 7/16	29 3/16	17			
120-150(a)	None	16	139 7/16	139 13/16	143 8/16	103 12/16	97 9/16	103 7/16	29 3/16	17			
	4 ft	16	139 7/16	139 13/16	143 8/16	103 12/16	97 9/16	103 7/16	29 3/16	17			
	8 ft	16	139 7/16	139 13/16	143 8/16	103 12/16	97 9/16	103 7/16	29 3/16	17			
120-150(b)	None	16	139 7/16	139 13/16	143 8/16	103 12/16	97 9/16	103 7/16	29 3/16	17			

(a) High Heat Gas Models Only

(b) High Heat Gas Models Only

Table 87. Unit dimensions (in.)—THREE-PIECE unit air-cooled—WITH energy recovery wheel

Tons	Blank Section	Unit Dimensions						Lifting Lug Locations					
		A	B	E	E1	E2	F	Air Handler Side					
								C1	C2	C3	C4	C5	C6
90	None	569 15/16	275 10/16	446 9/16	241 6/16	205 3/16	121 6/16	17 12/16	201 1/16	234 13/16	247 13/16	368 7/16	436 2/16
	4 ft	618 3/16	275 10/16	494 13/16	241 6/16	253 7/16	121 6/16	17 12/16	201 1/16	234 13/16	247 13/16	368 7/16	484 5/16
	8 ft	666 6/16	275 10/16	543	241 6/16	301 10/16	121 6/16	17 12/16	201 1/16	234 13/16	247 13/16	368 7/16	532 8/16
105	None	587 15/16	275 10/16	446 9/16	241 6/16	205 3/16	139 6/16	17 12/16	201 1/16	234 13/16	247 13/16	368 7/16	436 2/16
	4 ft	636 3/16	275 10/16	494 13/16	241 6/16	253 7/16	139 6/16	17 12/16	201 1/16	234 13/16	247 13/16	368 7/16	484 5/16
	8 ft	684 6/16	275 10/16	543	241 6/16	301 10/16	139 6/16	17 12/16	201 1/16	234 13/16	247 13/16	368 7/16	532 8/16
120-150(a)	None	667 15/16	318 15/16	517 9/16	257 8/16	260	148 6/16	17 12/16	204 7/16	252 12/16	263 12/16	391 5/16	507 1/16
	4 ft	716 2/16	318 15/16	565 12/16	257 8/16	308 4/16	148 6/16	17 12/16	204 7/16	252 12/16	263 12/16	391 5/16	555 4/16
	8 ft	764 5/16	318 15/16	613 15/16	257 8/16	356 7/16	148 6/16	17 12/16	204 7/16	252 12/16	263 12/16	391 5/16	603 7/16
120-150(a)	None	679 15/16	318 15/16	529 9/16	257 8/16	272	148 6/16	17 12/16	204 7/16	252 12/16	263 12/16	391 5/16	519 1/16



Dimensional Data

Table 87. Unit dimensions (in.)—THREE-PIECE unit air-cooled—WITH energy recovery wheel (continued)

Tons	Blank Section	Lug Locations		Unit Width		Unit Height			Return Fan	Exhaust Fan
		Condenser Side		M	N	O	P	R	J	K
		D1	D2							
90	None	16	112 7/16	139 13/16	143 8/16	103 12/16	97 9/16	103 7/16	N/A	17
	4 ft	16	112 7/16	139 13/16	143 8/16	103 12/16	97 9/16	103 7/16	N/A	17
	8 ft	16	112 7/16	139 13/16	143 8/16	103 12/16	97 9/16	103 7/16	N/A	17
105	None	16	130 7/16	139 13/16	143 8/16	103 12/16	97 9/16	103 7/16	N/A	17
	4 ft	16	130 7/16	139 13/16	143 8/16	103 12/16	97 9/16	103 7/16	N/A	17
	8 ft	16	130 7/16	139 13/16	143 8/16	103 12/16	97 9/16	103 7/16	N/A	17
120-150 ^(a)	None	16	139 7/16	139 13/16	143 8/16	103 12/16	97 9/16	103 7/16	N/A	17
	4 ft	16	139 7/16	139 13/16	143 8/16	103 12/16	97 9/16	103 7/16	N/A	17
	8 ft	16	139 7/16	139 13/16	143 8/16	103 12/16	97 9/16	103 7/16	N/A	17
120-150 ^(b)	None	16	139 7/16	139 13/16	143 8/16	103 12/16	97 9/16	103 7/16	N/A	17

^(a) High Heat Gas Models Only

^(b) High Heat Gas Models Only

Table 88. Unit dimensions (in.)—THREE-PIECE unit evaporative condensing—WITHOUT energy recovery wheel

Tons	Blank Section	Unit Dimensions						Lifting Lug Locations					
		A	B	E	E1	E2	F	Air Handler Side					
								C1	C2	C3	C4	C5	C6
100/118	None	494 13/16	179 3/16	350 3/16	144 15/16	205 3/16	142 10/16	11 14/16	N/A	138 9/16	151 6/16	272	339 11/16
	4 ft	543	179 3/16	398 6/16	144 15/16	253 7/16	142 10/16	11 14/16	N/A	138 9/16	151 6/16	272	387 14/16
	8 ft	591 4/16	179 3/16	446 9/16	144 15/16	301 10/16	142 10/16	11 14/16	N/A	138 9/16	151 6/16	272	436 1/16
128-162 ^(a)	None	565 12/16	222 9/16	421 2/16	161 2/16	260	142 10/16	11 14/16	N/A	155 2/16	167 5/16	294 14/16	410 10/16
	4 ft	613 15/16	222 9/16	469 5/16	161 2/16	308 4/16	142 10/16	11 14/16	N/A	155 2/16	167 5/16	294 14/16	458 13/16
	8 ft	662 3/16	222 9/16	517 9/16	161 2/16	356 7/16	142 10/16	11 14/16	N/A	155 2/16	167 5/16	294 14/16	507 1/16
128-162 ^(a)	None	577 12/16	222 9/16	433 2/16	161 2/16	272	142 10/16	11 14/16	N/A	155 2/16	167 5/16	294 14/16	422 10/16

Tons	Blank Section	Lug Locations		Unit Width		Unit Height			Return Fan	Exhaust Fan
		Condenser Side		M	N	O	P	R	J	K
		D1	D2							
100/118	None	16	133 11/16	139 13/16	143 8/16	103 12/16	97 9/16	102 12/16	29 3/16	17
	4 ft	16	133 11/16	139 13/16	143 8/16	103 12/16	97 9/16	102 12/16	29 3/16	17
	8 ft	16	133 11/16	139 13/16	143 8/16	103 12/16	97 9/16	102 12/16	29 3/16	17
128-162 ^(a)	None	16	133 11/16	139 13/16	143 8/16	103 12/16	97 9/16	102 6/16	29 3/16	17
	4 ft	16	133 11/16	139 13/16	143 8/16	103 12/16	97 9/16	102 6/16	29 3/16	17
	8 ft	16	133 11/16	139 13/16	143 8/16	103 12/16	97 9/16	102 6/16	29 3/16	17
128-162 ^(b)	None	16	133 11/16	139 13/16	143 8/16	103 12/16	97 9/16	102 6/16	29 3/16	17

^(a) High Heat Gas Models Only

^(b) High Heat Gas Models Only

Table 89. Unit dimensions (in.)—THREE-PIECE unit evaporative condensing—WITH energy recovery wheel

Tons	Blank Section	Unit Dimensions						Lifting Lug Locations					
		A	B	E	E1	E2	F	Air Handler Side					
								C1	C2	C3	C4	C5	C6
100/118	None	591 4/16	275 10/16	446 9/16	241 6/16	205 3/16	142 10/16	17 12/16	201 1/16	234 13/16	247 13/16	368 7/16	436 2/16
	4 ft	639 7/16	275 10/16	494 13/16	241 6/16	253 7/16	142 10/16	17 12/16	201 1/16	234 13/16	247 13/16	368 7/16	484 5/16
	8 ft	687 10/16	275 10/16	543	241 6/16	301 10/16	142 10/16	17 12/16	201 1/16	234 13/16	247 13/16	368 7/16	532 8/16
128-162 (a)	None	662 3/16	318 15/16	517 9/16	257 8/16	260	142 10/16	17 12/16	204 7/16	252 12/16	263 12/16	391 5/16	519 1/16
	4 ft	710 6/16	318 15/16	565 12/16	257 8/16	308 4/16	142 10/16	17 12/16	204 7/16	252 12/16	263 12/16	391 5/16	507 1/16
	8 ft	758 10/16	318 15/16	613 15/16	257 8/16	356 7/16	142 10/16	17 12/16	204 7/16	252 12/16	263 12/16	391 5/16	555 4/16
128-162 (a)	None	674 3/16	318 15/16	529 9/16	257 8/16	272	142 10/16	17 12/16	204 7/16	252 12/16	263 12/16	391 5/16	603 7/16

Tons	Blank Section	Lug Locations		Unit Width		Unit Height			Return Fan	Exhaust Fan
		Condenser Side		M	N	O	P	R	J	K
		D1	D2							
100/118	None	16	133 11/16	139 13/16	143 8/16	103 12/16	97 9/16	102 6/16	N/A	17
	4 ft	16	133 11/16	139 13/16	143 8/16	103 12/16	97 9/16	102 6/16	N/A	17
	8 ft	16	133 11/16	139 13/16	143 8/16	103 12/16	97 9/16	102 6/16	N/A	17
128-162 (a)	None	16	133 11/16	139 13/16	143 8/16	—	—	—	—	—
	4 ft	16	133 11/16	139 13/16	143 8/16	—	—	—	—	—
	8 ft	16	133 11/16	139 13/16	143 8/16	—	—	—	—	—
128-162 (b)	None	16	133 11/16	139 13/16	143 8/16	—	—	—	—	—

(a) High Heat Gas Models Only

(b) High Heat Gas Models Only

Table 90. Downflow/horizontal airflow configuration dimensions (in.) air-cooled (AC) and evaporative condensing (EC) without energy recovery wheel (ERW)

Tonnage AC/EC	Blank Section	Gas Heat	DOWNFLOW Opening Dimensions							
			Return Opening-with or without Exhaust Fan				Return Opening-with Return Fan			
			X1	Y1	W1	L1	X1	Y1	W1	L1
90-105/100-118	None	None	14 13/16	8 14/16	48 3/16	121 15/16	14 13/16	42 14/16	48 3/16	53 14/16
	4 ft	None	14 13/16	8 14/16	48 3/16	121 15/16	14 13/16	42 14/16	48 3/16	53 14/16
	8 ft	None	14 13/16	8 14/16	48 3/16	121 15/16	14 13/16	42 14/16	48 3/16	53 14/16
120-150/128-162	None	None	14 13/16	8 14/16	48 3/16	121 15/16	14 13/16	42 14/16	48 3/16	53 14/16
	4 ft	None	14 13/16	8 14/16	48 3/16	121 15/16	14 13/16	42 14/16	48 3/16	53 14/16
	8 ft	None	14 13/16	8 14/16	48 3/16	121 15/16	14 13/16	42 14/16	48 3/16	53 14/16
90-105/100-118	None	Low/Med	14 13/16	8 14/16	48 3/16	121 15/16	14 13/16	42 14/16	48 3/16	53 14/16
	8 ft	Low/Med	14 13/16	8 14/16	48 3/16	121 15/16	14 13/16	42 14/16	48 3/16	53 14/16
120-150/128-162	None	Low/Med	14 13/16	8 14/16	48 3/16	121 15/16	14 13/16	42 14/16	48 3/16	53 14/16
	8 ft	Low/Med	14 13/16	8 14/16	48 3/16	121 15/16	14 13/16	42 14/16	48 3/16	53 14/16
	None	High	14 13/16	8 14/16	48 3/16	121 15/16	14 13/16	42 14/16	48 3/16	53 14/16



Dimensional Data

Table 90. Downflow/horizontal airflow configuration dimensions (in.) air-cooled (AC) and evaporative condensing (EC) without energy recovery wheel (ERW) (continued)

Tonnage AC/EC	Blank Section	Gas Heat	DOWNFLOW Opening Dimensions					HORIZONTAL Opening Dimensions			
			Supply Opening					Return Side Opening			
			X2 (One or Two- Piece Models)	X2 (Three- Piece Models)	Y2	W2	L2	X3	Y3	W3	H1
90-105/100- 118	None	None	256 1/16	275 6/16	13	47 14/16	102 8/16	9 5/16	10 10/16	54 12/16	84 15/16
	4 ft	None	304 4/16	323 9/16	13	47 14/16	102 8/16	9 5/16	10 10/16	54 12/16	84 15/16
	8 ft	None	352 8/16	371 12/16	13	47 14/16	102 8/16	9 5/16	10 10/16	54 12/16	84 15/16
120-150/128- 162	None	None	320 13/16	346 4/16	13	47 14/16	102 8/16	—	—	—	—
	4 ft	None	369	394 8/16	13	47 14/16	102 8/16	—	—	—	—
	8 ft	None	417 3/16	442 11/16	13	47 14/16	102 8/16	9 5/16	10 10/16	54 12/16	84 15/16
90-105/100- 118	None	Low/Med	256 1/16	275 6/16	13	47 14/16	102 8/16	9 5/16	10 10/16	54 12/16	84 15/16
	8 ft	Low/Med	352 8/16	371 12/16	13	47 14/16	102 8/16	9 5/16	10 10/16	54 12/16	84 15/16
120-150/128- 162	None	Low/Med	320 13/16	346 4/16	13	47 14/16	102 8/16	9 5/16	10 10/16	54 12/16	84 15/16
	8 ft	Low/Med	417 3/16	442 11/16	13	47 14/16	102 8/16	9 5/16	10 10/16	54 12/16	84 15/16
	None	High	320 13/16	346 4/16	13	59 14/16	102 8/16	9 5/16	10 10/16	54 12/16	84 15/16
Tonnage AC/EC	Blank Section	Gas Heat	HORIZONTAL Opening Dimensions								
			Return End Opening				Supply Opening				
			Y1	Y3	H3	L1	X4 (One or Two- Piece Models)	X4 (Three Piece Models)	Y4	W4	H2
90-105/100- 118	None	None	6 5/16	8 3/16	35 3/16	127 2/16	254 12/16	274	10 10/16	54 12/16	84 15/16
	4 ft	None	6 5/16	8 3/16	35 3/16	127 2/16	302 15/16	322 4/16	10 10/16	54 12/16	84 15/16
	8 ft	None	6 5/16	8 3/16	35 3/16	127 2/16	351 2/16	370 7/16	10 10/16	54 12/16	84 15/16
120-150/128- 162	None	None	—	—	—	—	319 8/16	345	10 10/16	54 12/16	84 15/16
	4 ft	None	—	—	—	—	367 11/16	393 3/16	10 10/16	54 12/16	84 15/16
	8 ft	None	6 5/16	8 3/16	35 3/16	127 2/16	415 15/16	441 6/16	10 10/16	54 12/16	84 15/16
90-105/100- 118	None	Low/Med	6 5/16	8 3/16	35 3/16	127 2/16	254 12/16	274	10 10/16	54 12/16	66 11/16
	8 ft	Low/Med	6 5/16	8 3/16	35 3/16	127 2/16	351 2/16	370 7/16	10 10/16	54 12/16	84 15/16
120-150/128- 162	None	Low/Med	6 5/16	8 3/16	35 3/16	127 2/16	319 8/16	345	10 10/16	54 12/16	66 11/16
	8 ft	Low/Med	6 5/16	8 3/16	35 3/16	127 2/16	415 15/16	441 6/16	10 10/16	54 12/16	84 15/16
	None	High	6 5/16	8 3/16	35 3/16	127 2/16	319 8/16	345	10 10/16	66 12/16	66 11/16

Table 91. Downflow/horizontal airflow configuration dimensions (in.) air-cooled (AC) and evaporative condensing (EC) with energy recovery wheel

Tonnage AC/EC	Blank Section	Gas Heat	DOWNFLOW Opening Dimensions												
			Return Opening-with or without Exhaust Fan				Return Opening-with Return Fan				Supply Opening				
			X1	Y1	W1	L1	X1	Y1	W1	L1	X2 (One or Two-Piece Models)	X2 (Three-Piece Models)	Y2	W2	L2
90-105/100-118	None	None	82 3/16	8 14/16	49 10/16	121 15/16	N/A	N/A	N/A	N/A	352 8/16	371 12/16	13	47 14/16	102 8/16
	4 ft	None	82 3/16	8 14/16	49 10/16	121 15/16	N/A	N/A	N/A	N/A	400 11/16	420	13	47 14/16	102 8/16
	8 ft	None	82 3/16	8 14/16	49 10/16	121 15/16	N/A	N/A	N/A	N/A	448 15/16	468 3/16	13	47 14/16	102 8/16
120-150/128-162	None	None	82 3/16	8 14/16	49 10/16	121 15/16	N/A	N/A	N/A	N/A	417 4/16	442 11/16	13	47 14/16	102 8/16
	4 ft	None	82 3/16	8 14/16	49 10/16	121 15/16	N/A	N/A	N/A	N/A	465 7/16	490 14/16	13	47 14/16	102 8/16
	8 ft	None	82 3/16	8 14/16	49 10/16	121 15/16	N/A	N/A	N/A	N/A	513 10/16	539 2/16	13	47 14/16	102 8/16
90-105/100-118	None	Low/Med	82 3/16	8 14/16	49 10/16	121 15/16	N/A	N/A	N/A	N/A	352 8/16	371 12/16	13	47 14/16	102 8/16
	8 ft	Low/Med	82 3/16	8 14/16	49 10/16	121 15/16	N/A	N/A	N/A	N/A	448 15/16	468 3/16	13	47 14/16	102 8/16
120-150/128-162	None	Low/Med	82 3/16	8 14/16	49 10/16	121 15/16	N/A	N/A	N/A	N/A	417 4/16	442 11/16	13	47 14/16	102 8/16
	8 ft	Low/Med	82 3/16	8 14/16	49 10/16	121 15/16	N/A	N/A	N/A	N/A	513 10/16	539 2/16	13	47 14/16	102 8/16
	None	High	82 3/16	8 14/16	49 10/16	121 15/16	N/A	N/A	N/A	N/A	417 4/16	442 11/16	13	59 14/16	102 8/16
Tonnage AC/EC	Blank Section	Gas Heat	HORIZONTAL Opening Dimensions												
			Return Side Opening				Supply Opening								
			X3	Y3	W3	H1	X4 (One or Two-Piece Models)	X4 (Three Piece Models)	Y4	W4	H2				
90-105/100-118	None	None	71 8/16	10 10/16	54 12/16	43 6/16	351 3/16	370 7/16	10 10/16	54 12/16	84 15/16				
	4 ft	None	71 8/16	10 10/16	54 12/16	43 6/16	399 6/16	418 11/16	10 10/16	54 12/16	84 15/16				
	8 ft	None	71 8/16	10 10/16	54 12/16	43 6/16	447 10/16	466 14/16	10 10/16	54 12/16	84 15/16				
120-150/128-162	None	None	71 8/16	10 10/16	54 12/16	43 6/16	415 15/16	441 6/16	10 10/16	54 12/16	84 15/16				
	4 ft	None	71 8/16	10 10/16	54 12/16	43 6/16	464 2/16	489 10/16	10 10/16	54 12/16	84 15/16				
	8 ft	None	71 8/16	10 10/16	54 12/16	43 6/16	512 6/16	537 13/16	10 10/16	54 12/16	84 15/16				
90-105/100-118	None	Low/Med	71 8/16	10 10/16	54 12/16	43 6/16	351 3/16	370 7/16	10 10/16	54 12/16	66 11/16				
	8 ft	Low/Med	71 8/16	10 10/16	54 12/16	43 6/16	447 10/16	466 14/16	10 10/16	54 12/16	84 15/16				
120-150/128-162	None	Low/Med	71 8/16	10 10/16	54 12/16	43 6/16	415 15/16	441 6/16	10 10/16	54 12/16	66 11/16				
	8 ft	Low/Med	71 8/16	10 10/16	54 12/16	43 6/16	512 6/16	537 13/16	10 10/16	54 12/16	84 15/16				
	None	High	71 8/16	10 10/16	54 12/16	43 6/16	415 15/16	441 6/16	10 10/16	66 12/16	66 11/16				

Notes:

1. On horizontal return with ERW units, the return end opening can be on the front, rear, or both sides of the unit and must be specified.
2. ERW is not allowed w/ end return



Water Connection Locations

Figure 36. Evaporative condenser water connection locations

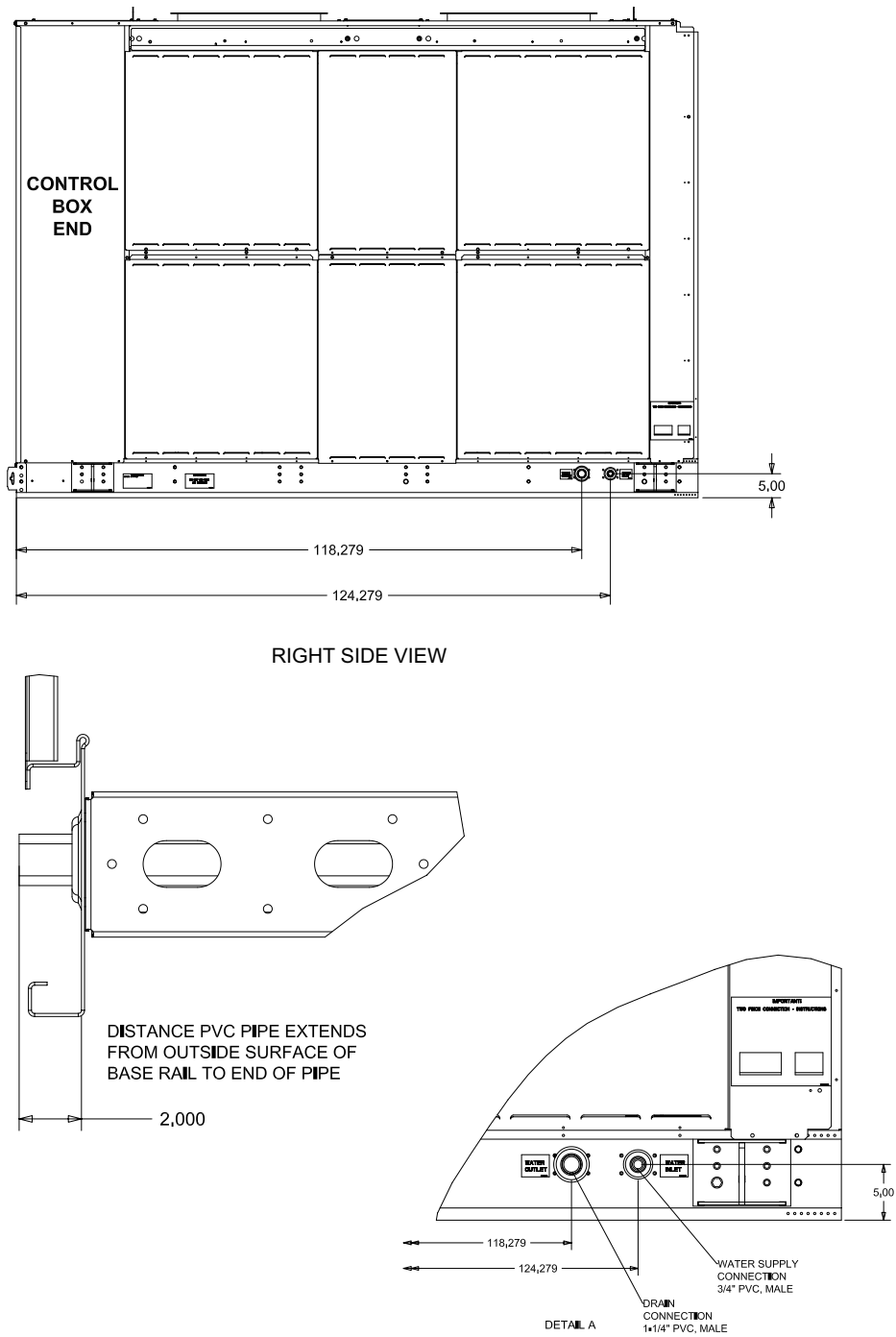

Electrical Entry Details

Figure 37. Electrical entry details/bottom view

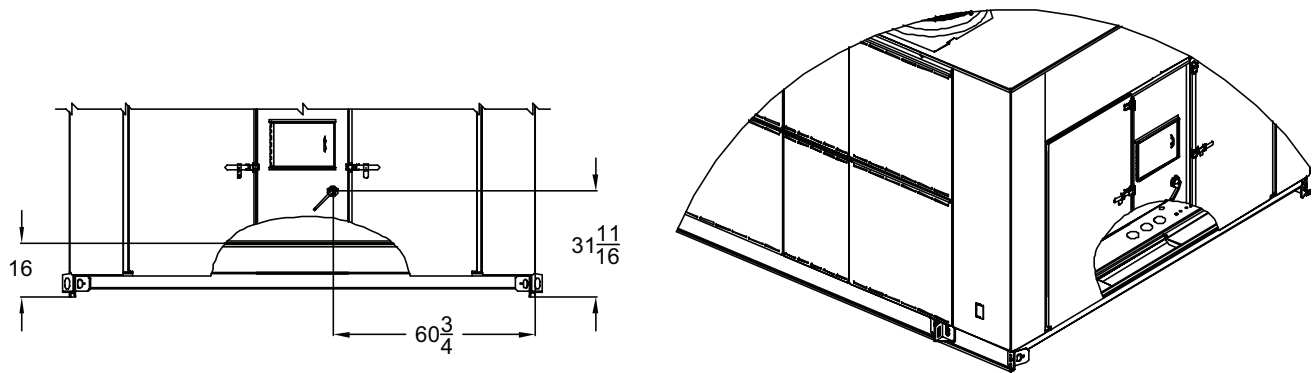

Bottom View

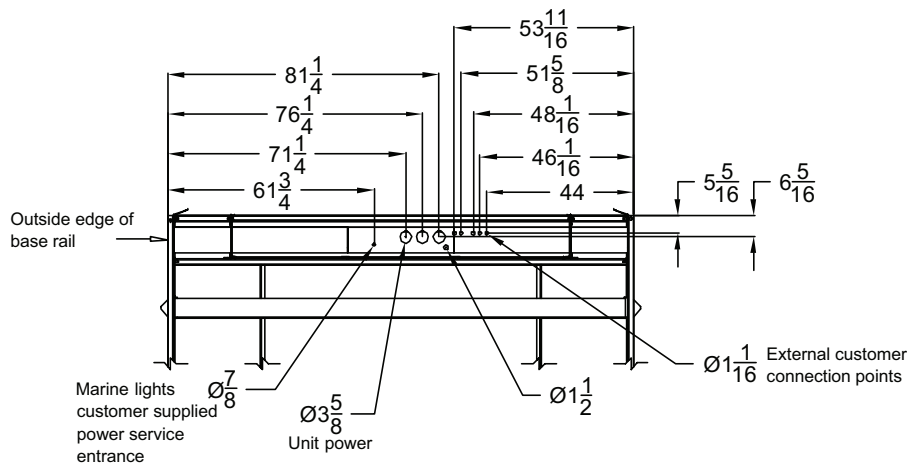

Minimum Required Clearance

Figure 38. Minimum required clearance

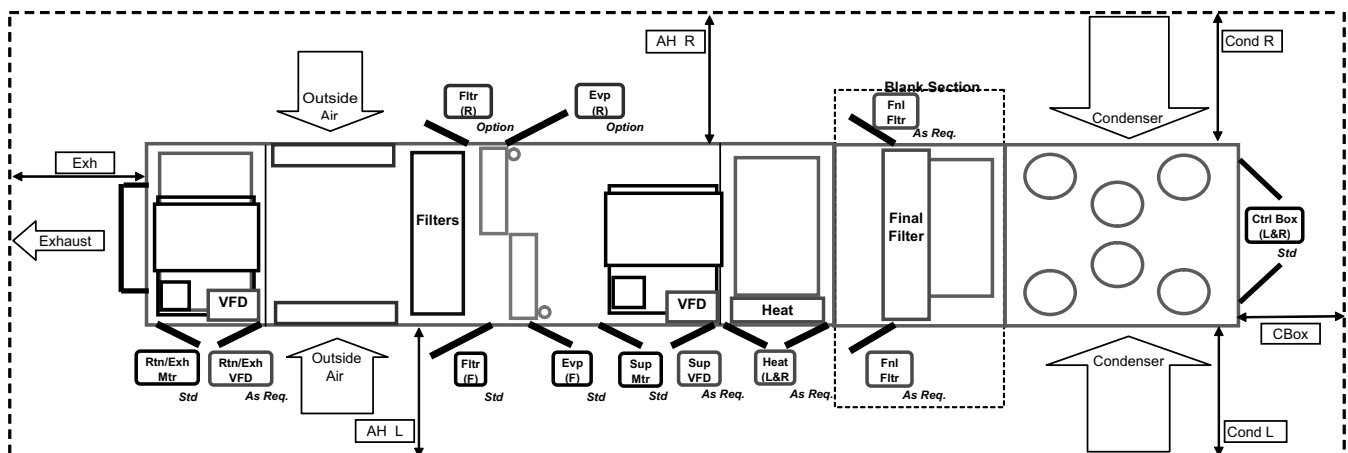

Note: Unit drawing is representative only and may not accurately depict all models.

Dimensional Data

Table 92. Minimum required clearance

Door Location	Availability	Unit Option Selection (Door Swing Ft. and In.)									
		Standard		VFD		Heat Electric/ Hot Water/ Steam	Reheat	Two-side Access		Final Filter	Energy Recovery
		90-118	120-162	Return/ Exhaust	Supply			90-118	120-162		
Exhaust/Ret Motor	Std	2' 2"	2' 2"	*	*	*	*	*	*	*	
Exhaust/Ret VFD	As Req.	*	*	2' 2"	*	*	*	*	*	*	
ERW Filtr (L & R) (F)	Option	*	*	*	*	*	*	*	*	*	2' 2"
ERW Filtr(a) (L & R) (R)	Option	*	*	*	*	*	*	*	*	*	2' 2"
Filter (Front)	Std	2' 8"	2' 8"	*	*	*	*	*	*	*	
Filter (Rear)	Option	*	*	*	*	*	*	2' 2"	2' 8"	*	
Evap (Front)	Std	2' 2"	2' 2"	*	*	*	*	*	*	*	
Evap (Rear)	Std	2' 8"	*	*	*	*	*	*	*	*	
or Evap (Rear)	Option	*	*	*	*	*	2' 2"	*	2' 2"	*	
Supply Motor	Std	2' 8"	2' 8"	*	*	*	*	*	*	*	
Supply VFD	As Req.	*	*	*	2' 2"	*	*	*	*	*	
Heat (Left & Right)	As Req.	*	*	*	*	2' 2"	*	*	*	*	
Final Filter (Front)	As Req.	*	*	*	*	*	*	*	*	2' 2"	
Final Filter (Rear)	As Req.	*	*	*	*	*	*	*	*	2' 2"	
Control Box (L & R)	Std	3' 2"	3' 2"	*	*	*	*	*	*	*	

Minimum Required Clearance (Ft.)	AH_L	AH_R	Exh	Cond_L	Cond_R	Control Box
	8'	8'	8'	8'	8'	6'

Note: See Unit Dimensions for Energy Recovery Wheel location.

Optional Roof Curb

Figure 39. Optional roof curb (downflow)

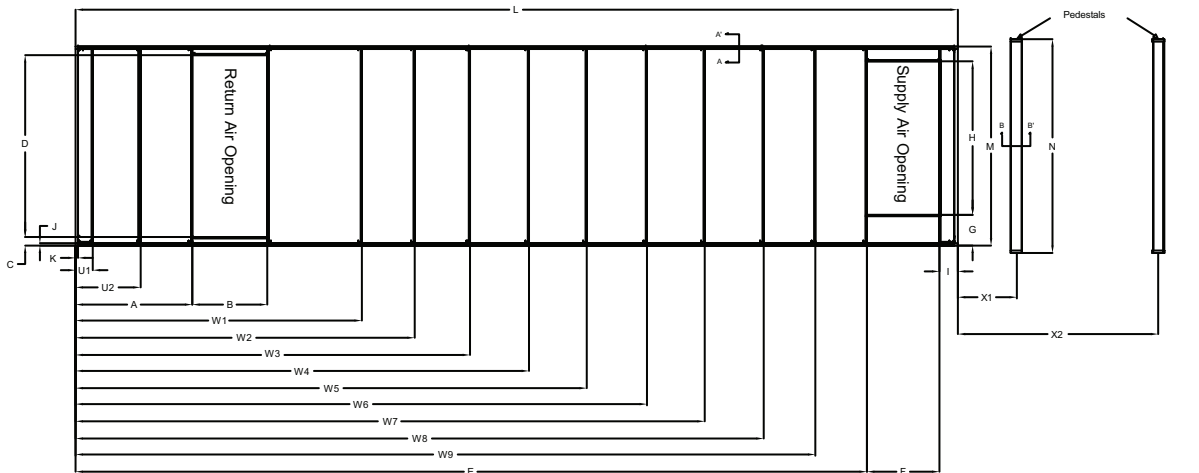

Note: All dimensions measured from top flange of roof curb

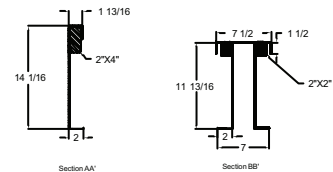

Table 93. Roof curb dimensions, ONE or TWO-piece unit without energy recovery wheel (in.)

Tons		Blank Section	Dimensions								
AC	EC		A	B	C	D	E	F	G	H	I
90-105	100-118	None	11 15/16	49 8/16	5 15/16	123	253 2/16	49 8/16	20 15/16	104	11 15/16
90-105	100-118	4 ft	11 15/16	49 8/16	5 15/16	123	301 5/16	49 8/16	20 15/16	104	11 15/16
90-105	100-118	8 ft	11 15/16	49 8/16	5 15/16	123	349 9/16	49 8/16	20 15/16	104	11 15/16
120-150 (a)	128-162 (a)	None	11 15/16	49 8/16	5 15/16	123	317 14/16	49 8/16	20 15/16	104	11 15/16
120-150	128-162	4 ft	11 15/16	49 8/16	5 15/16	123	366 2/16	49 8/16	20 15/16	104	11 15/16
120-150	128-162	8 ft	11 15/16	49 8/16	5 15/16	123	414 5/16	49 8/16	20 15/16	104	11 15/16
120-150 (b)	128-162 (b)	None	11 15/16	49 8/16	5 15/16	123	317 14/16	49 8/16	20 15/16	104	11 15/16
Tons		Blank Section	Dimensions								
AC	EC		J	K	L	M					
90-105	100-118	None	1 13/16	1 13/16	314 9/16	134 14/16					
90-105	100-118	4 ft	1 13/16	1 13/16	362 12/16	134 14/16					
90-105	100-118	8 ft	1 13/16	1 13/16	411	134 14/16					
120-150 (c)	128-162 (a)	None	1 13/16	1 13/16	379 5/16	134 14/16					
120-150	128-162	4 ft	1 13/16	1 13/16	427 8/16	134 14/16					
120-150	128-162	8 ft	1 13/16	1 13/16	475 12/16	134 14/16					
120-150 (d)	128-162 (b)	None	1 13/16	1 13/16	391 5/16	134 14/16					

- (a) Except High Heat Gas Models
- (b) High Heat Gas Models Only
- (c) Except High Heat Gas Models
- (d) High Heat Gas Models Only

Table 94. Roof curb cross member dimensions, ONE or TWO-piece unit without energy recovery wheel (in.)

Tons		Blank Section	Cross Member Locations							
AC	EC		W1	W2	W3	W4	W5	W6	W7	W8
90-105	100-118	None	103 6/16	145 11/16	183 6/16	218 4/16	N/A	N/A	N/A	N/A
90-105	100-118	4 ft	103 6/16	145 11/16	187 15/16	231 10/16	266 8/16	N/A	N/A	N/A
90-105	100-118	8 ft	103 6/16	145 11/16	189 15/16	234 3/16	279 13/16	314 11/16	N/A	N/A
120-150 (a)	128-162 (a)	None	103 6/16	145 11/16	179 6/16	213 1/16	248 2/16	289	N/A	N/A
120-150	128-162	4 ft	103 6/16	145 11/16	181 11/16	217 12/16	255 3/16	296 6/16	331 4/16	N/A
120-150	128-162	8 ft	103 6/16	145 11/16	185 4/16	224 13/16	265 12/16	304 7/16	344 9/16	379 7/16
120-150 (b)	128-162 (b)	None	103 6/16	145 11/16	179 5/16	213 1/16	248 2/16	289	N/A	N/A

- (a) Except High Heat Gas Models
- (b) High Heat Gas Models Only

Table 95. Roof curb dimensions, ONE or TWO-piece unit with energy recovery wheel (in.)

Tons		Blank Section	Dimensions								
AC	EC		A	B	C	D	E	F	G	H	I
90-105	100-118	None	79 5/16	50 12/16	5 15/16	123	349 9/16	49 8/16	20 15/16	104	11 15/16
90-105	100-118	4 ft	79 5/16	50 12/16	5 15/16	123	397 12/16	49 8/16	20 15/16	104	11 15/16
90-105	100-118	8 ft	79 5/16	50 12/16	5 15/16	123	446	49 8/16	20 15/16	104	11 15/16
120-150 (a)	128-162 (a)	None	79 5/16	50 12/16	5 15/16	123	414 5/16	49 8/16	20 15/16	104	11 15/16
120-150	128-162	4 ft	79 5/16	50 12/16	5 15/16	123	462 8/16	49 8/16	20 15/16	104	11 15/16
120-150	128-162	8 ft	79 5/16	50 12/16	5 15/16	123	510 12/16	49 8/16	20 15/16	104	11 15/16
120-150 (b)	128-162 (b)	None	79 5/16	50 12/16	5 15/16	123	414 5/16	49 8/16	20 15/16	104	11 15/16
Tons		Blank Section	Dimensions								
AC	EC		J	K	L	M					
90-105	100-118	None	1 13/16	1 13/16	411	134 14/16					
90-105	100-118	4 ft	1 13/16	1 13/16	459 3/16	134 14/16					
90-105	100-118	8 ft	1 13/16	1 13/16	507 6/16	134 14/16					



Dimensional Data

Table 95. Roof curb dimensions, ONE or TWO-piece unit with energy recovery wheel (in.) (continued)

Tons		Blank Section	Dimensions			
AC	EC		J	K	L	M
120-150 (c)	128-162 (a)	None	1 13/16	1 13/16	476 1/16	134 14/16
120-150	128-162	4 ft	1 13/16	1 13/16	524 4/16	134 14/16
120-150	128-162	8 ft	1 13/16	1 13/16	572 8/16	134 14/16
120-150 (d)	128-162 (b)	None	1 13/16	1 13/16	488 1/16	134 14/16

- (a) Except High Heat Gas Models
- (b) High Heat Gas Models Only
- (c) Except High Heat Gas Models
- (d) High Heat Gas Models Only

Table 96. Roof curb cross member dimensions, ONE or TWO-piece unit with energy recovery wheel (in.)

Tons		Blank Section	Cross Member Locations										
AC	EC		U1	U2	W1	W2	W3	W4	W5	W6	W7	W8	
90-105	100-118	None	11 15/16	43 15/16	168 10/16	204 11/16	242 1/16	279 13/16	314 11/16	N/A	N/A	N/A	
90-105	100-118	4 ft	11 15/16	43 15/16	168 10/16	204 11/16	242 1/16	284 6/16	328	362 14/16	N/A	N/A	
90-105	100-118	8 ft	11 15/16	43 15/16	168 10/16	204 11/16	242 1/16	286 5/16	330 9/16	376 4/16	411 2/16	N/A	
120-150 (a)	128-162 (a)	None	11 15/16	43 15/16	168 10/16	204 11/16	242 1/16	275 12/16	309 8/16	344 9/16	385 7/16	N/A	
120-150	128-162	4 ft	11 15/16	43 15/16	168 10/16	204 11/16	242 1/16	278 2/16	314 3/16	351 9/16	392 12/16	427 10/16	
120-150	128-162	8 ft	11 15/16	43 15/16	168 10/16	204 11/16	242 1/16	281 10/16	321 3/16	362 3/16	400 14/16	441	
120-150 (b)	128-162 (b)	None	11 15/16	43 15/16	168 10/16	204 11/16	242 1/16	275 12/16	309 8/16	344 9/16	385 7/16	N/A	
Tons		Blank Section	Cross Member Locations										
AC	EC		W9										
90-105	100-118	None	N/A										
90-105	100-118	4 ft	N/A										
90-105	100-118	8 ft	N/A										
120-150 (c)	128-162 (a)	None	N/A										
120-150	128-162	4 ft	N/A										
120-150	128-162	8 ft	475 14/16										
120-150 (d)	128-162 (b)	None	N/A										

- (a) Except High Heat Gas Models
- (b) High Heat Gas Models Only
- (c) Except High Heat Gas Models
- (d) High Heat Gas Models Only

Table 97. Roof curb cross member dimensions, THREE-piece unit without energy recovery wheel (in.)

Tons		Blank Section	Cross Member Locations							
AC	EC		U1	U2	W1	W2	W3	W4	W5	W6
90-105	100-118	None	N/A	N/A	103 6/16	145 11/16	202 11/16	237 9/16	N/A	N/A
90-105	100-118	4 ft	N/A	N/A	103 6/16	145 11/16	187 15/16	250 14/16	285 12/16	N/A
90-105	100-118	8 ft	N/A	N/A	103 6/16	145 11/16	189 15/16	234 3/16	299 1/16	333 15/16
120-150 (a)	128-162 (a)	None	N/A	N/A	103 6/16	145 11/16	179 6/16	213 1/16	273 10/16	314 8/16
120-150	128-162	4 ft	N/A	N/A	103 6/16	145 11/16	181 11/16	217 12/16	255 3/16	321 13/16
120-150	128-162	8 ft	N/A	N/A	103 6/16	145 11/16	185 4/16	224 13/16	265 12/16	304 7/16
120-150 (b)	128-162 (b)	None	N/A	N/A	103 6/16	145 11/16	179 6/16	213 1/16	273 10/16	314 8/16
Tons		Blank Section	Cross Member Locations							
AC	EC		W7	W8	W9					
90-105	100-118	None	N/A	N/A	N/A					
90-105	100-118	4 ft	N/A	N/A	N/A					

Table 97. Roof curb cross member dimensions, THREE-piece unit without energy recovery wheel (in.) (continued)

Tons		Blank Section	Cross Member Locations		
AC	EC		W7	W8	W9
90-105	100-118	8 ft	N/A	N/A	N/A
120-150 (c)	128-162 (a)	None	N/A	N/A	N/A
120-150	128-162	4 ft	356 11/16	N/A	N/A
120-150	128-162	8 ft	370 1/16	404 15/16	N/A
120-150 (d)	128-162 (b)	None	N/A	N/A	N/A

- (a) Except High Heat Gas Models
- (b) High Heat Gas Models Only
- (c) Except High Heat Gas Models
- (d) High Heat Gas Models Only

Table 98. Roof curb dimensions, THREE-piece unit without energy recovery wheel (in.)

Tons		Blank Section	Dimensions									
AC	EC		A	B	C	D	E	F	G	H	I	J
90-105	100-118	None	11 15/16	49 8/16	5 15/16	123	272 7/16	49 8/16	20 15/16	104	11 15/16	1 13/16
90-105	100-118	4 ft	11 15/16	49 8/16	5 15/16	123	320 10/16	49 8/16	20 15/16	104	11 15/16	1 13/16
90-105	100-118	8 ft	11 15/16	49 8/16	5 15/16	123	368 13/16	49 8/16	20 15/16	104	11 15/16	1 13/16
120-150 (a)	128-162 (a)	None	11 15/16	49 8/16	5 15/16	123	343 6/16	49 8/16	20 15/16	104	11 15/16	1 13/16
120-150	128-162	4 ft	11 15/16	49 8/16	5 15/16	123	391 9/16	49 8/16	20 15/16	104	11 15/16	1 13/16
120-150	128-162	8 ft	11 15/16	49 8/16	5 15/16	123	439 13/16	49 8/16	20 15/16	104	11 15/16	1 13/16
120-150 (b)	128-162 (b)	None	11 15/16	49 8/16	5 15/16	123	343 6/16	61 8/16	20 15/16	104	11 15/16	1 13/16

Tons		Blank Section	Dimensions		
AC	EC		K	L	M
90-105	100-118	None	1 13/16	333 13/16	134 14/16
90-105	100-118	4 ft	1 13/16	382 1/16	134 14/16
90-105	100-118	8 ft	1 13/16	430 4/16	134 14/16
120-150 (c)	128-162 (a)	None	1 13/16	404 13/16	134 14/16
120-150	128-162	4 ft	1 13/16	453	134 14/16
120-150	128-162	8 ft	1 13/16	501 3/16	134 14/16
120-150 (d)	128-162 (b)	None	1 13/16	416 13/16	134 14/16

- (a) Except High Heat Gas Models
- (b) High Heat Gas Models Only
- (c) Except High Heat Gas Models
- (d) High Heat Gas Models Only

Table 99. Roof curb cross member dimensions, THREE-piece unit without energy recovery wheel (in.)

Tons		Blank Section	Cross Member Locations						
AC	EC		U1	U2	W1	W2	W3	W4	W5
90-105	100-118	None	11 15/16	43 15/16	168 10/16	204 11/16	242 1/16	299 1/16	333 15/16
90-105	100-118	4 ft	11 15/16	43 15/16	168 10/16	204 11/16	242 1/16	284 6/16	347 5/16
90-105	100-118	8 ft	11 15/16	43 15/16	168 10/16	204 11/16	242 1/16	286 5/16	330 9/16
120-150 (a)	128-162 (a)	None	11 15/16	43 15/16	168 10/16	204 11/16	242 1/16	275 12/16	309 8/16
120-150	128-162	4 ft	11 15/16	43 15/16	168 10/16	204 11/16	242 1/16	278 2/16	314 3/16
120-150	128-162	8 ft	11 15/16	43 15/16	168 10/16	204 11/16	242 1/16	281 10/16	321 3/16
120-150 (b)	128-162 (b)	None	11 15/16	43 15/16	168 10/16	204 11/16	242 1/16	275 12/16	309 8/16



Dimensional Data

Table 99. Roof curb cross member dimensions, THREE-piece unit without energy recovery wheel (in.) (continued)

Tons		Blank Section	Cross Member Locations			
AC	EC		W6	W7	W8	W9
90-105	100-118	None	N/A	N/A	N/A	N/A
90-105	100-118	4 ft	382 3/16	N/A6	N/A	N/A
90-105	100-118	8 ft	395 8/16	430 6/16	N/A	N/A
120-150 (c)	128-162 (a)	None	370 1/16	410 15/16	N/A	N/A
120-150	128-162	4 ft	351 9/16	418 4/16	453 2/16	N/A
120-150	128-162	8 ft	362 3/16	400 14/16	466 7/16	501 5/16
120-150 (d)	128-162 (b)	None	370 1/16	410 15/16	N/A	N/A

- (a) Except High Heat Gas Models
 (b) High Heat Gas Models Only
 (c) Except High Heat Gas Models
 (d) High Heat Gas Models Only

Table 100. Roof curb dimensions, THREE-piece unit with energy recovery wheel (in.)

Tons		Blank Section	Dimensions												
AC	EC		A	B	C	D	E	F	G	H	I	J	K	L	
90-105	100-118	None	79 5/16	50 12/16	5 15/16	123	368 13/16	49 8/16	20 15/16	104	11 15/16	1 13/16	1 13/16	430 4/16	
90-105	100-118	4 ft	79 5/16	50 12/16	5 15/16	123	417 1/16	49 8/16	20 15/16	104	11 15/16	1 13/16	1 13/16	478 8/16	
90-105	100-118	8 ft	79 5/16	50 12/16	5 15/16	123	465 4/16	49 8/16	20 15/16	104	11 15/16	1 13/16	1 13/16	526 11/16	
120-150(a)	128-162(a)	None	79 5/16	50 12/16	5 15/16	123	439 12/16	49 8/16	20 15/16	104	11 15/16	1 13/16	1 13/16	501 8/16	
120-150	128-162	4 ft	79 5/16	50 12/16	5 15/16	123	488	49 8/16	20 15/16	104	11 15/16	1 13/16	1 13/16	549 12/16	
120-150	128-162	8 ft	79 5/16	50 12/16	5 15/16	123	536 3/16	49 8/16	20 15/16	104	11 15/16	1 13/16	1 13/16	597 15/16	
120-150(b)	128-162(b)	None	79 5/16	50 12/16	5 15/16	123	439 12/16	61 8/16	20 15/16	104	11 15/16	1 13/16	1 13/16	513 8/16	
Tons		Blank Section	Dimen- sions												
AC	EC		M												
90-105	100-118	None	134 14/16												
90-105	100-118	4 ft	134 14/16												
90-105	100-118	8 ft	134 14/16												
120-150(c)	128-162(a)	None	134 14/16												
120-150	128-162	4 ft	134 14/16												
120-150	128-162	8 ft	134 14/16												
120-150(d)	128-162(b)	None	134 14/16												

- (a) Except High Heat Gas Models
 (b) High Heat Gas Models Only
 (c) Except High Heat Gas Models
 (d) High Heat Gas Models Only

Table 101. Roof curb cross member dimensions, THREE-piece unit with energy recovery (in.)

Tons		Blank Section	Cross Member Locations						
AC	EC		U1	U2	W1	W2	W3	W4	W5
90-105	100-118	None	11 15/16	43 15/16	168 10/16	204 11/16	242 1/16	299 1/16	333 15/16
90-105	100-118	4 ft	11 15/16	43 15/16	168 10/16	204 11/16	242 1/16	284 6/16	347 5/16
90-105	100-118	8 ft	11 15/16	43 15/16	168 10/16	204 11/16	242 1/16	286 5/16	330 9/16
120-150 (a)	128-162 (a)	None	11 15/16	43 15/16	168 10/16	204 11/16	242 1/16	275 12/16	309 8/16
120-150	128-162	4 ft	11 15/16	43 15/16	168 10/16	204 11/16	242 1/16	278 2/16	314 3/16
120-150	128-162	8 ft	11 15/16	43 15/16	168 10/16	204 11/16	242 1/16	281 10/16	321 3/16
120-150 (b)	128-162 (b)	None	11 15/16	43 15/16	168 10/16	204 11/16	242 1/16	275 12/16	309 8/16
Tons		Blank Section	Cross Member Locations						
AC	EC		W6	W7	W8	W9			
90-105	100-118	None	N/A	N/A	N/A	N/A			
90-105	100-118	4 ft	382 3/16	N/A6	N/A	N/A			

Table 101. Roof curb cross member dimensions, THREE-piece unit with energy recovery (in.) (continued)

Tons		Blank Section	Cross Member Locations			
AC	EC		W6	W7	W8	W9
90-105	100-118	8 ft	395 8/16	430 6/16	N/A	N/A
120-150 (c)	128-162 (a)	None	370 1/16	410 15/16	N/A	N/A
120-150	128-162	4 ft	351 9/16	418 4/16	453 2/16	N/A
120-150	128-162	8 ft	362 3/16	400 14/16	466 7/16	501 5/16
120-150 (d)	128-162 (b)	None	370 1/16	410 15/16	N/A	N/A

(a) Except High Heat Gas Models

(b) High Heat Gas Models Only

(c) Except High Heat Gas Models

(d) High Heat Gas Models Only

Table 102. Pedestal dimensions

Tons	One-, Two-, Three-Piece Unit	Condenser Type	Pedestal Dimensions		
			N	X1	X2
90	1	Air-Cooled	145.25	N/A	93 1/16
90	2 or 3	Air-Cooled	145.25	36 3/16	111 3/16
105	1	Air-Cooled	145.25	N/A	111 1/16
105	2 or 3	Air-Cooled	145.25	36 3/16	129 3/16
120-150	1	Air-Cooled	145.25	N/A	117 1/16
120-150	2 or 3	Air-Cooled	145.25	40 3/16	136 3/16
100-162	2 or 3	Evaporative Condensing	145.25	36 3/16	129.1875

Sensors

Figure 40. Field installed zone sensor—programmable night setback sensor (BAYSENS119*)

Figure 41. Field installed zone sensor—with timed override button and local setpoint adjustment (BAYSENS074*), with timed override only (BAYSENS073*), sensor only (BAYSENS077*)



Note: Remote sensors are available for use with all zone sensors to provide remote sensing capabilities.

Figure 42. Field installed temperature sensor (BAYSENS016*)

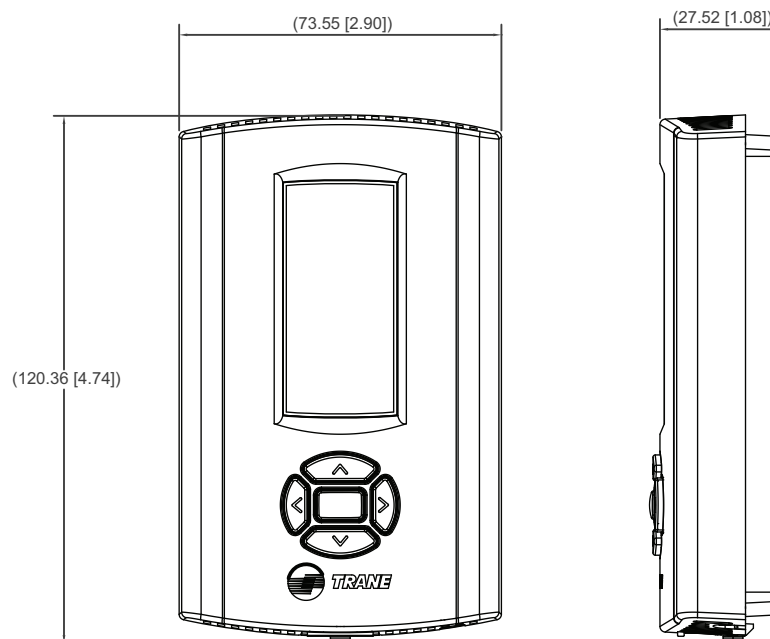
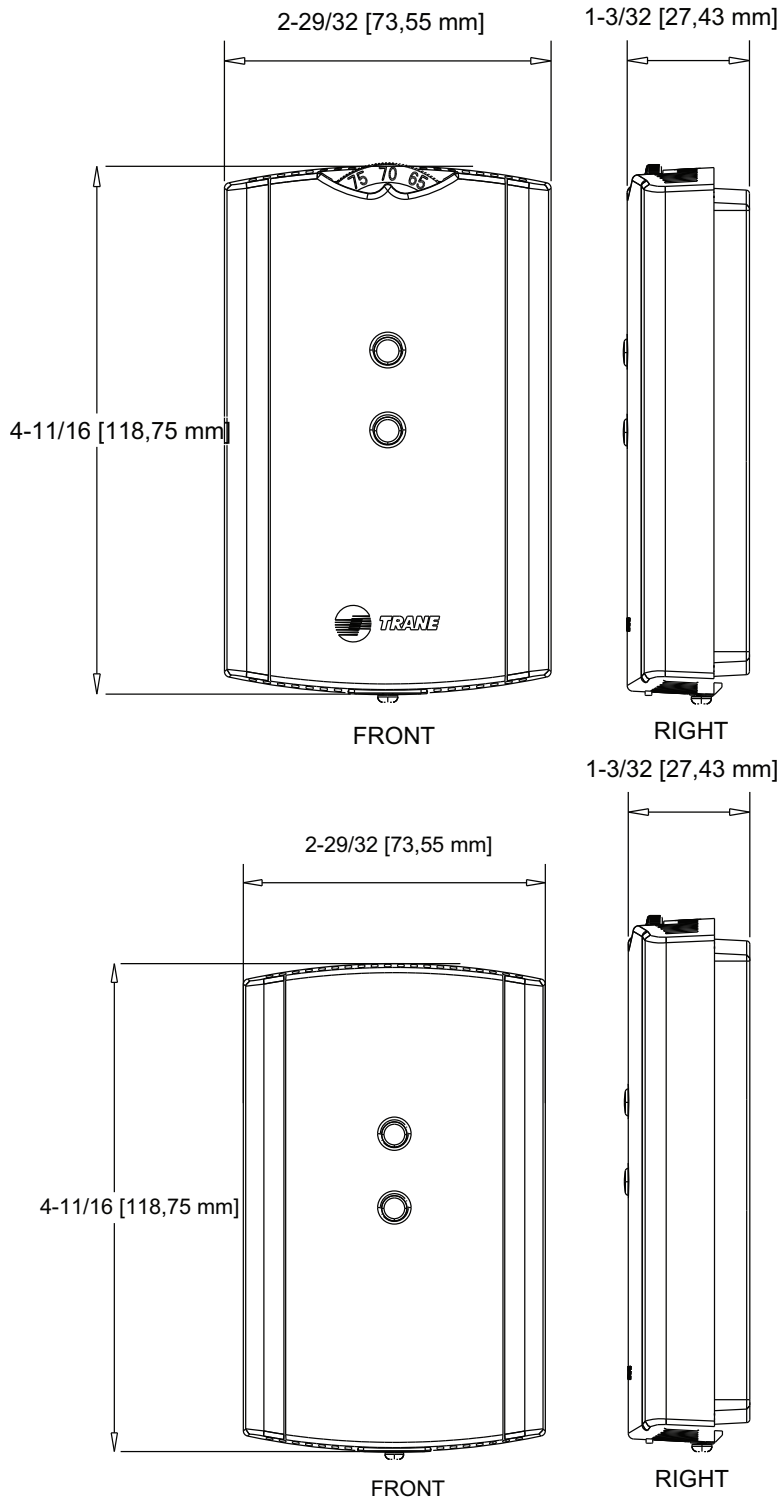

Figure 43. Field installed remote minimum position potentiometer control (BAYSTAT023*)

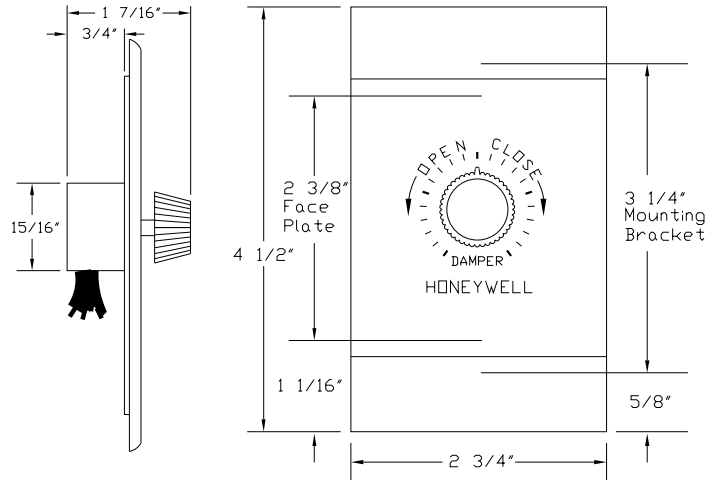
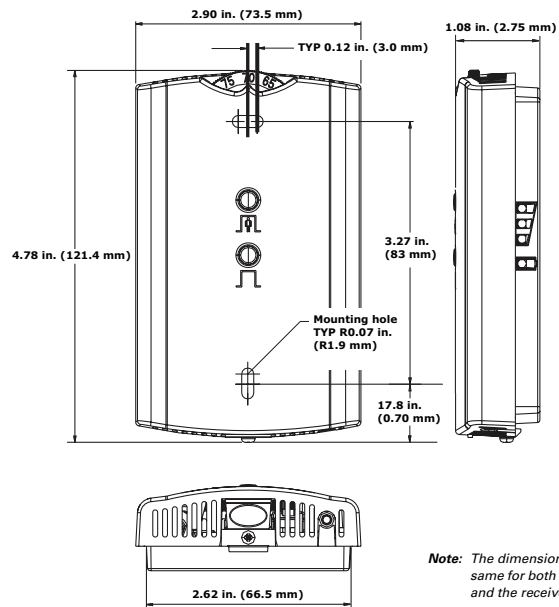

Figure 44. Field installed zone sensor—wireless



Note: The dimensions are the same for both the sensor and the receiver.



Weights

Table 103. Approximate operating weights (lbs.)

Air-Cooled Units			Evaporative Condensing Units		
Nominal Tons	Unit (Minimum)	Roof Curb (Minimum)	Nominal Tons	Unit (Minimum)	Roof Curb (Minimum)
90	13731	907	100	18430	1055
105	14792	907	118	18941	1055
120	16939	1040	128	21362	1194
130	17241	1040	140	21348	1194
150	17923	1040	162	21470	1194

Notes:

- Weights shown for air-cooled units include the following features: standard coils, 0-25% Outside Air, throwaway filters, low CFM supply fan, minimum motor sizes, constant volume, 460 XL, No heat. Weights shown for Evaporative-condensing units include high-capacity evaporator coil and the weight of the extra structure associated with a two piece unit. Add 1300 lbs for installed sump base water weight for evaporative condenser total operating weight.
- Weights shown represent approximate minimum operating weights. To calculate weight for a specific unit configuration, utilize TOPSS or contact the local Trane sales representative. Weight outputs have a + 10% accuracy. ACTUAL WEIGHTS ARE STAMPED ON THE UNIT NAMEPLATE.

Table 104. Component weights

	90/100		105/118		120/128		130/140		150/162	
	Size	Weight	Size	Weight	Size	Weight	Size	Weight	Size	Weight
Refrigeration										
Compressor Assy. - Fixed capacity compressors	-	1126	-	1344	-	1562	-	1616	-	1670
Compressor Assy. - eFlex™ Variable speed (air cooled only)	-	1479	-	1503	-	1626	-	1754	-	1786
Air-Cooled Condensing Coil (Al)	-	623	-	722	-	1049	-	1224	-	924
Evaporative Condensing Coil	-	4566	-	4329	-	4129	-	4109	-	4029
Evap Coil - Std. Cap	-	1034	-	1300	-	1664	-	1892	-	2564
Evap Coil - Hi. Cap.	-	1382	-	1462	-	2564	-	2496	-	N/A
Reheat Coil & Tubing	-	292	-	294	-	367	-	367	-	367
Replaceable Core Filter Driers	-	26	-	25	-	35	-	35	-	35
HGBP	-	46	-	49	-	53	-	53	-	53
Supply Fan Assembly										
Supply Fan & Fan Board Assy. - Low CFM	25"	1159	32"	1361	32"	1361	32"	1361	32"	1361
Supply Fan & Fan Board Assy. - Std. CFM	36"	1490	36"	1490	40"	1653	40"	1653	40"	1653
Belt Guard	-	116	-	116	-	116	-	116	-	116
Supply VFD (50 hp and below)	-	233	-	233	-	233	-	233	-	233
Supply VFD (60-100 hp)	-	284	-	284	-	284	-	284	-	284
Supply-Exh Fan Motor - 15 hp	-	181	-	181	-	181	-	181	-	181
Supply-Exh Fan Motor - 20 hp	-	206	-	206	-	206	-	206	-	206
Supply-Exh Fan Motor - 25 hp	-	358	-	358	-	358	-	358	-	358
Supply-Exh Fan Motor - 30 hp	-	413	-	413	-	413	-	413	-	413
Supply-Exh Fan Motor - 40 hp	-	495	-	495	-	495	-	495	-	495
Supply-Exh Fan Motor - 50 hp	-	604	-	604	-	604	-	604	-	604
Supply-Exh Fan Motor - 60 hp	-	776	-	776	-	776	-	776	-	776
Supply-Exh Fan Motor - 75 hp	-	879	-	879	-	879	-	879	-	879
Supply-Exh Fan Motor - 100 hp	-	1102	-	1102	-	1102	-	1102	-	1102
Return/Exhaust Fan Assembly										
Return Fan & Dampers - Low CFM	36"	2294	36"	2294	36"	2294	36"	2294	36"	2294
Return Fan & Dampers - Std. CFM	40"	2343	40"	2343	44"	2445	44"	2445	44"	2445
Exhaust Fan & Dampers - Low CFM	25"	889	28"	979	28"	979	28"	979	28"	979
Exhaust Fan & Dampers - Std. CFM	28"	979	32"	1429	32"	1429	32"	1429	32"	1429
Belt Guard	-	119	-	119	-	119	-	119	-	119
Exhaust VFD (50 hp and below)	-	244	-	244	-	244	-	244	-	244

Table 104. Component weights (continued)

	90/100		105/118		120/128		130/140		150/162	
	Size	Weight	Size	Weight	Size	Weight	Size	Weight	Size	Weight
Exhaust VFD (60-100 hp)	-	295	-	295	-	295	-	295	-	295
Exh Fan Motor - 7.5 hp	-	160	-	160	-	160	-	160	-	160
Exh Fan Motor - 10 hp	-	181	-	181	-	181	-	181	-	181
Exh Fan Motor - 15 hp	-	206	-	206	-	206	-	206	-	206
Exh Fan Motor - 20 hp	-	206	-	206	-	206	-	206	-	206
Exh Fan Motor - 25 hp	-	358	-	358	-	358	-	358	-	358
Exh Fan Motor - 30 hp	-	413	-	413	-	413	-	413	-	413
Exh Fan Motor - 40 hp	-	495	-	495	-	495	-	495	-	495
Exh Fan Motor - 50 hp	-	604	-	604	-	604	-	604	-	604
Exh Fan Motor - 60 hp	-	776	-	776	-	776	-	776	-	776
Heat										
Gas Heat Low	0.85 M	690	0.85M	690	1.1M	840	1.1M	840	1.1M	840
Gas Heat Med	1.1 M	840	1.1M	840	1.8M	1150	1.8M	1150	1.8M	1150
Gas Heat High	1.8 M	1150	1.8M	1150	2.5M	1398 ^(a)	2.5M	1398 ^(a)	2.5M	1398 ^(a)
Electric Heat	-	485	-	485	-	485	-	485	-	485
Steam Heat Low	-	753	-	753	-	802	-	802	-	802
Steam Heat High	-	821	-	821	-	886	-	886	-	886
Hot Water Heat Low	-	773	-	773	-	841	-	841	-	841
Hot Water Heat High	-	818	-	818	-	897	-	897	-	897
Filters										
Filter Rack - Throwaway Filters	-	181	-	181	-	191	-	191	-	191
Filter Rack - Bag Filters	-	395	-	395	-	395	-	395	-	395
Filter Rack - Cartridge Filters	-	662	-	662	-	662	-	662	-	662
Final Filters - Bag Filters	-	392	-	392	-	392	-	392	-	392
Final Filters - Cartridge Filters w/ 2" pre-filter	-	607	-	607	-	607	-	607	-	607
Final Filters - Cartridge Filters w/ 4" pre-filter	-	638	-	638	-	638	-	638	-	638
Final Filters - High Temp. Cartridge	-	669	-	669	-	669	-	669	-	669
Final Filters - HEPA	-	1777	-	1777	-	1777	-	1777	-	1777
Final Filters - HEPA High Temp.	-	1839	-	1839	-	1839	-	1839	-	1839
Outside Air										
0-25% Damper	-	637	-	637	-	699	-	699	-	699
Econ	-	760	-	760	-	865	-	865	-	865
Econ w/ Air Measure	-	724	-	724	-	807	-	807	-	807
ERW, Low CFM w/ Econ ^(b)	-	3307	-	3307	-	3518	-	3681	-	3681
ERW, High CFM w/ Econ ^(b)	-	3545	-	3514	-	3756	-	3756	-	3756
ERW, Low CFM w/ Econ & Air Measure ^(b)	-	3487	-	3487	-	3727	-	3890	-	3890
ERW, High CFM w/ Econ & Air Measure ^(b)	-	3725	-	3694	-	3965	-	3965	-	3965
Cabinet										
Cabinet	-	8097	-	8315	-	9473	-	9473	-	9473
Cabinet - 4' Blank Section	-	935	-	935	-	901	-	901	-	901
Cabinet - 8' Blank Section	-	1709	-	1709	-	1682	-	1682	-	1682
Control Box - Main										
Control Box - Main	-	519	-	519	-	519	-	519	-	519
Convenience Outlet	-	36	-	36	-	36	-	36	-	36
Low Ambient VFD	-	57	-	57	-	57	-	57	-	57
2/3 Piece Unit Adder										
2 Piece Adder	-	406	-	406	-	406	-	406	-	406
3 Piece Adder	-	1157	-	1157	-	1236	-	1236	-	1236
Air-Cooled Condenser										
Total Weight of Condenser Section	-	4637	-	5201	-	6015	-	6075	-	6092

^(a) Evaporative Condenser weight includes the additional weight in the cabinet structure, coil weight and additional refrigerant charge. Add 1300 lbs for operating sump base water weight.

^(b) Energy Recovery includes weight associated w/ 96" of cabinet length.