

PROJECT REPORT

TO: ENVIRONMENTAL EVALUATION COMMITTEE
FROM: PLANNING & DEVELOPMENT SERVICES

AGENDA DATE: June 13, 2024
AGENDA TIME: 1:30PM / No. 2

Apex Energy Solutions, LLC (NorthStar 1)
PROJECT TYPE: General Plan Amendment #23-0001, Zone Change #23-0001 SUPERVISOR DIST # 4
Conditional Use Permits #23-0005 & #23-0006 003-110-005-000
LOCATION: 8997 Wilkins Road APN: 003-110-007-000
Calipatria, CA PARCEL SIZE: 288-AC

GENERAL PLAN (existing) Agriculture GENERAL PLAN (proposed) N/A

ZONE (existing): S-2-RE/G (Open Space/Preservation, Renewable Energy/Geothermal)

ZONE (proposed): N/A / S-2-RE (Open Space/ Preservation, Renewable Energy)

GENERAL PLAN FINDINGS CONSISTENT INCONSISTENT MAY BE/FINDINGS

PLANNING COMMISSION DECISION: HEARING DATE: _____

APPROVED DENIED OTHER

PLANNING DIRECTORS DECISION: HEARING DATE: _____

APPROVED DENIED OTHER

ENVIROMENTAL EVALUATION COMMITTEE DECISION: HEARING DATE: 06-13-2024

INITIAL STUDY: #23-0006

NEGATIVE DECLARATION MITIGATED NEG. DECLARATION EIR

DEPARTMENTAL REPORTS / APPROVALS:

PUBLIC WORKS	<input checked="" type="checkbox"/>	NONE	<input type="checkbox"/>	ATTACHED
AG	<input type="checkbox"/>	NONE	<input checked="" type="checkbox"/>	ATTACHED
APCD	<input type="checkbox"/>	NONE	<input checked="" type="checkbox"/>	ATTACHED
E.H.S.	<input checked="" type="checkbox"/>	NONE	<input type="checkbox"/>	ATTACHED
FIRE / OES	<input type="checkbox"/>	NONE	<input checked="" type="checkbox"/>	ATTACHED
SHERIFF	<input checked="" type="checkbox"/>	NONE	<input type="checkbox"/>	ATTACHED

OTHER Imperial Irrigation District, CEO's office, Caltrans, Agua Caliente
Band of Cahuilla Indians, Viejas Tribe, and Dept. of Fish & Wildlife

REQUESTED ACTION:

(See Attached)

Planning & Development Services

801 MAIN ST., EL CENTRO, CA, 92243 760-482-4236

GQVATIS:\AllUsers\APN\0031110\005\GPA23-0001 ZC23-0001 CUP23-0005 CUP23-0006 IS23-0006\EEC\NorthStar 1 PROJECT REPORT.docx



Initial Study

North Star 1 Solar and Battery Storage Project

Initial Study #23-0006

General Plan Amendment #23-0001

Zone Change #23-0001

Conditional Use Permits #23-0005 and #23-0006

Imperial County CA

June 2024

Reviewed by:

County of Imperial

Planning & Development
Services Department

801 Main Street

El Centro, CA 92243

Prepared by:

HDR Engineering, Inc.

591 Camino de la Reina,
Suite 300

San Diego, CA 92108

This page is intentionally blank.



Contents

Introduction	4
A. Purpose	4
B. CEQA Requirements and the Imperial County’s Rules and Regulations for Implementing CEQA	4
C. Intended Uses of Initial Study	5
D. Contents of Initial Study	5
E. Scope of Environmental Analysis	5
F. Policy-Level or Project-Level Environmental Analysis	6
G. Tiered Documents and Incorporation by Reference	6
Environmental Checklist Form	9
Environmental Factors Potentially Affected	11
Environmental Evaluation Committee Determination	11
Project Summary	13
Project Location	13
Renewable Energy Overlay Zone	13
Environmental Setting	13
Project Components	13
Solar Energy Facility	14
Battery Energy Storage System	14
On-Site Substation	14
Off-Site Gen-tie Line	14
Security	15
Site Access	15
Fire Protection/Fire Suppression	15
Construction	16
Operations	16
Water Use	16
Restoration of the Project Site	16
Project Approvals	17
Evaluation of Environmental Impacts	23
References	103
List of Preparers	105
Imperial County Planning and Development Services Department	105
HDR	105
Technical Report Preparers	105
Findings	107

Tables

Table 1. Unmitigated Project Construction-Generated Emissions	35
Table 2. Mitigated Project Construction-Generated Emissions	36
Table 3. Operational-Related Emissions (Regional Significance Analysis)	37
Table 4. Vegetation Communities and Land Covers in Project Site and in 500-foot Buffer	41
Table 5. CNPS Status Designations	44
Table 6. Cultural Resources within the Project Area	59
Table 7. CRHR/NRHP Eligibility of Cultural Resources within Project Area	61
Table 8. Automotive Fuel Consumption in Imperial County 2016-2021	66
Table 9. Proposed Project Energy and Fuel Consumption	66
Table 10. Construction-Related GHG Emissions	72
Table 11. Operational-Related GHG Emissions	72
Table 12. Proposed Project Displaced GHG Emissions	73
Table 13. Project Consistency with “Adjacent to the Existing RE Overlay Zone” Criteria	83
Table 14. Construction Average (dBA) Noise Levels at Nearest Receptor	86
Table 15. Modeled Operational Noise Levels at Nearest Receptor	87
Table 16. Representative Vibration Source Levels for Construction Equipment	88
Table 17. Construction Vibration Levels at 350 Feet	88

Figures

Figure 1. Regional Location	19
Figure 2. Project Vicinity	20
Figure 3. Project Components	21
Figure 4. View from KOP 1	29
Figure 5. Vegetation Communities and Land Cover Types	42
Figure 6. Special-Status Wildlife Species Observed within Survey Area	46
Figure 7. Flood Zone Map	80

Appendices

Appendix A	Visual Resources Impact Assessment
Appendix B	Air Quality and Greenhouse Gas Emissions Assessment
Appendix C	Biological Technical Report
Appendix D	Aquatic Resource Delineation Report
Appendix E1	Cultural Resources Inventory Report (Confidential)
Appendix E2	Archaeological and Architectural History Resources Evaluations (Confidential)
Appendix F	Energy Consumption Assessment
Appendix G	Geotechnical Report
Appendix H	Phase I Environmental Site Assessment



- Appendix I Noise Impact Assessment
- Appendix J Traffic, Parking, and Circulation Assessment
- Appendix K Water Supply Assessment

Introduction

A. Purpose

This document is a policy-level; project-level Initial Study for evaluation of potential environmental impacts resulting with the proposed North Star 1 Solar and Battery Storage Project.

B. CEQA Requirements and the Imperial County's Rules and Regulations for Implementing CEQA

As defined by Section 15063 of the State California Environmental Quality Act (CEQA) Guidelines and Section 7 of the County's Rules and Regulations for Implementing CEQA, an **Initial Study** is prepared primarily to provide the Lead Agency with information to use as the basis for determining whether an Environmental Impact Report (EIR), Negative Declaration, or Mitigated Negative Declaration would be appropriate for providing the necessary environmental documentation and clearance for any proposed project.

- According to Section 15065, an **EIR** is deemed appropriate for a particular proposal if the following conditions occur:
 - The proposal has the potential to substantially degrade the quality of the environment.
 - The proposal has the potential to achieve short-term environmental goals to the disadvantage of long-term environmental goals.
 - The proposal has possible environmental effects that are individually limited but cumulatively considerable.
 - The proposal could cause direct or indirect adverse effects on human beings.
- According to Section 15070(a), a **Negative Declaration** is deemed appropriate if the proposal would not result in any significant effect on the environment.
- According to Section 15070(b), a **Mitigated Negative Declaration** is deemed appropriate if it is determined that though a proposal could result in a significant effect, mitigation measures are available to reduce these significant effects to insignificant levels.

This Initial Study has determined that the proposed North Star 1 Solar and Battery Storage Project will result in potentially significant environmental impacts; however, mitigation measures are available to reduce the potentially significant impacts and therefore, a Mitigated Negative Declaration is deemed as the appropriate document to provide necessary environmental evaluations and clearance for the proposed approvals under review in this Initial Study.

This Initial Study is prepared in conformance with the California Environmental Quality Act of 1970, as amended (Public Resources Code, Section 21000 et. seq.); the State CEQA Guidelines & County of Imperial's CEQA Regulations, Guidelines for the Implementation of CEQA; applicable requirements of the County of Imperial; and the regulations, requirements, and procedures of any other responsible public agency or an agency with jurisdiction by law.

Pursuant to the County of Imperial's CEQA Regulations, Guidelines for the Implementation of CEQA, depending on the project scope, the County of Imperial Board of Supervisors, Planning Commission

and/or Planning Director is designated the Lead Agency, in accordance with Section 15050 of the CEQA Guidelines. The Lead Agency is the public agency which has the principal responsibility for approving the necessary environmental clearances and analyses for any project in the County.

C. Intended Uses of Initial Study

This Initial Study is an informational document which is intended to inform County of Imperial decision makers, other responsible or interested agencies, and the general public of potential environmental effects of the proposed applications. The environmental review process has been established to enable public agencies to evaluate environmental consequences and to examine and implement methods of eliminating or reducing any potentially adverse impacts. While CEQA requires that consideration be given to avoiding environmental damage, the Lead Agency and other responsible public agencies must balance adverse environmental effects against other public objectives, including economic and social goals.

The Initial Study prepared for the project will be circulated for a period of no less than 35 days for public and agency review and comments.

D. Contents of Initial Study

This Initial Study is organized to facilitate a basic understanding of the existing setting and environmental implications of the proposed applications.

SECTION 1

I. INTRODUCTION presents an introduction to the entire report. This section discusses the environmental process, scope of environmental review, and incorporation by reference documents.

SECTION 2

II. ENVIRONMENTAL CHECKLIST FORM contains the County's Environmental Checklist Form. The checklist form presents results of the environmental evaluation for the North Star 1 Project and those issue areas that would have either a significant impact, potentially significant impact, or no impact.

PROJECT SUMMARY, LOCATION AND ENVIRONMENTAL SETTINGS describes the proposed project, necessary entitlements and required applications. A description of discretionary approvals and permits required for project implementation is also included. It also identifies the location of the project and a general description of the surrounding environmental settings.

ENVIRONMENTAL ANALYSIS evaluates each response provided in the environmental checklist form. Each response checked in the checklist form is discussed and supported with sufficient data and analysis as necessary. As appropriate, each response discussion describes and identifies specific impacts anticipated with project implementation.

SECTION 3

III. MANDATORY FINDINGS presents Mandatory Findings of Significance in accordance with Section 15065 of the CEQA Guidelines.

E. Scope of Environmental Analysis

For evaluation of environmental impacts, each question from the Environmental Checklist Form is summarized and responses are provided according to the analysis undertaken as part of the Initial

Study. Impacts and effects will be evaluated and quantified, when appropriate. To each question, there are four possible responses, including:

1. No Impact: A “No Impact” response is adequately supported if the impact simply does not apply to the proposed project.
2. Less Than Significant Impact: The proposed project will have the potential to impact the environment. These impacts, however, will be less than significant; no additional analysis is required.
3. Less Than Significant With Mitigation Incorporated: This applies where incorporation of mitigation measures has reduced an effect from “Potentially Significant Impact” to a “Less Than Significant Impact.”
4. Potentially Significant Impact: The proposed project could have impacts that are considered significant. Additional analyses and possibly an EIR could be required to identify mitigation measures that could reduce these impacts to less than significant levels.

F. Policy-Level or Project-Level Environmental Analysis

This Initial Study will be conducted under a policy-level, project-level analysis.

Regarding mitigation measures, it is not the intent of this document to “overlap” or restate conditions of approval that are commonly established for future known projects or the proposed project and associated entitlement applications. Additionally, those other standard requirements and regulations that any development must comply with, that are outside the County’s jurisdiction, are also not considered mitigation measures, and therefore, will not be identified in this document.

G. Tiered Documents and Incorporation by Reference

Information, findings, and conclusions contained in this document are based on incorporation by reference of tiered documentation, which are discussed in the following section.

1. Tiered Documents

As permitted in Section 15152(a) of the CEQA Guidelines, information and discussions from other documents can be included into this document. Tiering is defined as follows:

“Tiering refers to using the analysis of general matters contained in a broader EIR (such as the one prepared for a general plan or policy statement) with later EIRs and negative declarations on narrower projects; incorporating by reference the general discussions from the broader EIR; and concentrating the later EIR or negative declaration solely on the issues specific to the later project.”

Tiering also allows this document to comply with Section 15152(b) of the CEQA Guidelines, which discourages redundant analyses, as follows:

“Agencies are encouraged to tier the environmental analyses which they prepare for separate but related projects including the general plans, zoning changes, and development projects. This approach can eliminate repetitive discussion of the same issues and focus the later EIR or negative declaration on the actual issues ripe for decision at each level of environmental review. Tiering is appropriate when the sequence of analysis is from an EIR prepared for a

general plan, policy or program to an EIR or negative declaration for another plan, policy, or program of lesser scope, or to a site-specific EIR or negative declaration.”

Further, Section 15152(d) of the CEQA Guidelines states:

“Where an EIR has been prepared and certified for a program, plan, policy, or ordinance consistent with the requirements of this section, any lead agency for a later project pursuant to or consistent with the program, plan, policy, or ordinance should limit the EIR or negative declaration on the later project to effects which:

- (1) Were not examined as significant effects on the environment in the prior EIR; or
- (2) Are susceptible to substantial reduction or avoidance by the choice of specific revisions in the project, by the imposition of conditions, or other means.”

2. Incorporation by Reference

Incorporation by reference is a procedure for reducing the size of EIRs/MND and is most appropriate for including long, descriptive, or technical materials that provide general background information, but do not contribute directly to the specific analysis of the project itself. This procedure is particularly useful when an EIR or Negative Declaration relies on a broadly-drafted EIR for its evaluation of cumulative impacts of related projects (*Las Virgenes Homeowners Federation v. County of Los Angeles* [1986, 177 Ca.3d 300]). If an EIR or Negative Declaration relies on information from a supporting study that is available to the public, the EIR or Negative Declaration cannot be deemed unsupported by evidence or analysis (*San Francisco Ecology Center v. City and County of San Francisco* [1975, 48 Ca.3d 584, 595]).

When an EIR or Negative Declaration incorporates a document by reference, the incorporation must comply with Section 15150 of the CEQA Guidelines as follows:

- The incorporated document must be available to the public or be a matter of public record (CEQA Guidelines Section 15150[a]). The General Plan EIR is available, along with this document, at the County of Imperial Planning & Development Services Department, 801 Main Street, El Centro, CA 92243 Ph. (442) 265-1736.
- This document must be available for inspection by the public at an office of the lead agency (CEQA Guidelines Section 15150[b]). These documents are available at the County of Imperial Planning & Development Services Department, 801 Main Street, El Centro, CA 92243, Ph. (442) 265-1736.
- These documents must summarize the portion of the document being incorporated by reference or briefly describe information that cannot be summarized. Furthermore, these documents must describe the relationship between the incorporated information and the analysis in the tiered documents (CEQA Guidelines Section 15150[c]). As discussed above, the tiered EIRs address the entire project site and provide background and inventory information and data which apply to the project site. Incorporated information and/or data will be cited in the appropriate sections.
- These documents must include the State identification number of the incorporated documents (CEQA Guidelines Section 15150[d]). The State Clearinghouse Number for the County of Imperial General Plan EIR is SCH #93011023.



The material to be incorporated in this document will include general background information (CEQA Guidelines Section 15150[f]).

Environmental Checklist Form

3. **Project Title:** North Star 1 Solar and Battery Storage Project
4. **Lead Agency Name and Address:** Imperial County Planning & Development Services Department, 801 Main Street, El Centro, CA 92243
5. **Contact Person and Phone Number:** Gerardo Quero, Planner II, 442-265-1748
6. **Project Location:** The proposed project is located on an approximately 288-acre project site consisting of two parcels (Assessor Parcel Number (APN) 003-110-005 and APN 003-110-007. APN 003-110-005 encompasses approximately 111 acres and APN 003-110-007 encompasses approximately 176 acres in the eastern portion of Imperial County, California. The project site is located approximately seven miles north of the unincorporated community of Niland and approximately 8.2 miles east of the community of Bombay Beach, between the East Highline Canal and Coachella Canal. The Salton Sea is located approximately 3.5 miles west of the project site. Highway 111 is approximately 2.6 miles west of the project site. Local unpaved roads provide access to the project site from Highway 111. Federal lands managed by the Bureau of Land Management (BLM) are located immediately east of the project site.
7. **Project Sponsor's Name and Address:** Apex Energy Solutions, LLC, 750 W. Main Street, El Centro, CA 92243
8. **General Plan Designation:** Agriculture
9. **Zoning:** Open Space/Preservation (S-2) and Open Space/Preservation in Renewable Energy Zone (S-2-RE)
10. **Description of Project:** The proposed project consists of four primary components: 1) 50-megawatt (MW) solar photovoltaic (PV) facility; 2) 75-MW battery energy storage system (BESS); 3) on-site substation; and 4) off-site transmission line to connect to the Imperial Irrigation District's (IID) existing 161 kilovolt (kV) "N" Line. The solar facility, BESS, on-site substation, and off-site transmission line are collectively referred to as the "proposed project" or "project." A detailed project description is provided in the Project Summary section below.
11. **Surrounding Land Uses and Setting: Briefly describe the project's surroundings:**

The project site is surrounded by vacant desert land to the west, north, and east and agricultural land to the south within unincorporated Imperial County. Federal lands managed by the BLM are located immediately east of the project site. The project site is currently characterized by flat and undeveloped desert landscape. One single-family residence is located approximately 450 feet to the west of the project site. The existing IID 161-kV "N" Line is located adjacent to Coachella Canal Road to the east of the project site.
12. **Other public agencies whose approval is required (e.g., permits, financing approval, or participation agreement.):**
 - California Regional Water Quality Control Board, Colorado River Basin Region
 - Imperial County Air Pollution Control District
 - Imperial County Public Works Department

13. Have California Native American tribes traditionally and culturally affiliated with the project area requested consultation pursuant to Public Resources Code section 21080.3.1? If so, is there a plan for consultation that includes, for example, the determination of significance of impacts to tribal cultural resources, procedures regarding confidentiality, etc.?

Yes, California Native American tribes that are traditionally and culturally affiliated with the project area were sent an Assembly Bill (AB) 52/Senate Bill (SB) 18 consultation request letter on December 22, 2023. On February 1, 2024, the Agua Caliente Band of Cahuilla Indians responded via letter requesting consultation under SB 18.

Environmental Factors Potentially Affected

The environmental factors checked below would be potentially affected by this project, involving at least one impact that is a "Potentially Significant Impact" as indicated by the checklist on the following pages.

- | | | |
|--|---|--|
| <input type="checkbox"/> Aesthetics | <input type="checkbox"/> Agriculture and Forestry Resources | <input checked="" type="checkbox"/> Air Quality |
| <input checked="" type="checkbox"/> Biological Resources | <input checked="" type="checkbox"/> Cultural Resources | <input type="checkbox"/> Energy |
| <input checked="" type="checkbox"/> Geology/Soils | <input type="checkbox"/> Greenhouse Gas Emissions | <input type="checkbox"/> Hazards & Hazardous Materials |
| <input type="checkbox"/> Hydrology / Water Quality | <input type="checkbox"/> Land Use/Planning | <input type="checkbox"/> Mineral Resources |
| <input type="checkbox"/> Noise | <input type="checkbox"/> Population/Housing | <input type="checkbox"/> Public Services |
| <input type="checkbox"/> Recreation | <input type="checkbox"/> Transportation | <input checked="" type="checkbox"/> Tribal Cultural Resources |
| <input type="checkbox"/> Utilities/Service Systems | <input type="checkbox"/> Wildfire | <input checked="" type="checkbox"/> Mandatory Findings of Significance |

Environmental Evaluation Committee Determination

After Review of the Initial Study, the Environmental Evaluation Committee (EEC) has:

- Found that the proposed project COULD NOT have a significant effect on the environment, and a NEGATIVE DECLARATION will be prepared.
- Found that although the proposed project could have a significant effect on the environment, there will not be a significant effect in this case because revisions in the project have been made by or agreed to by the project proponent. A MITIGATED NEGATIVE DECLARATION will be prepared.
- Found that the proposed project MAY have a significant effect on the environment, and an ENVIRONMENTAL IMPACT REPORT is required.
- Found that the proposed project MAY have a "potentially significant impact" or "potentially significant unless mitigated" impact on the environment, but at least one effect 1) has been adequately analyzed in an earlier document pursuant to applicable legal standards, and 2) has been addressed by mitigation measures based on the earlier analysis as described on attached sheets. An ENVIRONMENTAL IMPACT REPORT is required, but it must analyze only the effects that remain to be addressed.
- Found that although the proposed project could have a significant effect on the environment, because all potentially significant effects (a) have been analyzed adequately in an earlier EIR or NEGATIVE DECLARATION pursuant to applicable standards, and (b) have been avoided or mitigated pursuant to that earlier EIR or NEGATIVE DECLARATION, including revisions or mitigation measures that are imposed upon the proposed project, nothing further is required.

EEC VOTES	YES	NO	ABSENT
PUBLIC WORKS	<input type="checkbox"/>	<input type="checkbox"/>	<input type="checkbox"/>
ENVIRONMENTAL HEALTH	<input type="checkbox"/>	<input type="checkbox"/>	<input type="checkbox"/>
OFFICE EMERGENCY SERVICES	<input type="checkbox"/>	<input type="checkbox"/>	<input type="checkbox"/>
APCD	<input type="checkbox"/>	<input type="checkbox"/>	<input type="checkbox"/>
AG	<input type="checkbox"/>	<input type="checkbox"/>	<input type="checkbox"/>
SHERIFF DEPARTMENT	<input type="checkbox"/>	<input type="checkbox"/>	<input type="checkbox"/>
ICPDS	<input type="checkbox"/>	<input type="checkbox"/>	<input type="checkbox"/>

Jim Minnick, Director of Planning/EEC Chairman

Date:

Project Summary

Project Location

The proposed project is located on an approximately 288-acre project site consisting of two parcels (Assessor Parcel Number (APN) 003-110-005 and APN 003-110-007. APN 003-110-005 encompasses approximately 111 acres and APN 003-110-007 encompasses approximately 176 acres in the eastern portion of Imperial County, California (Figure 1). The project site is located approximately 7 miles north of the unincorporated community of Niland and approximately 8.2 miles east of the community of Bombay Beach, between the East Highline Canal and Coachella Canal (Figure 2). Highway 111 is approximately 2.6 miles west of the project site. Local unpaved roads provide access to the project site from Highway 111. Federal lands managed by the Bureau of Land Management (BLM) are located immediately east of the project site.

Renewable Energy Overlay Zone

In 2016, the County adopted the Imperial County Renewable Energy and Transmission Element, which includes an RE Zone (RE Overlay Map). This General Plan element was created as part of the California Energy Commission Renewable Energy Grant Program to amend and update the County's General Plan to facilitate future development of renewable energy projects.

The County Land Use Ordinance, Division 17, includes the RE Overlay Zone, which authorizes the development and operation of renewable energy projects with an approved conditional use permit (CUP). The RE Overlay Zone is concentrated in areas determined to be the most suitable for the development of renewable energy facilities while minimizing the impact on other established uses. CUP applications proposed for specific renewable energy projects not located in the RE Overlay Zone would not be allowed without an amendment to the RE Overlay Zone.

Of the two parcels that comprise the project site, APN 003-110-005 is within the County's RE Overlay Zone; however, APN 003-110-007 is outside of the RE Overlay Zone. Therefore, the applicant is requesting a General Plan Amendment and Zone Change to include/classify APN 003-110-007 into the RE Overlay Zone. The underlying "Agriculture" General Plan designation would remain.

Environmental Setting

The project site is surrounded by vacant desert land to the west, north, and east and agricultural land to the south within unincorporated Imperial County. Federal lands managed by the BLM are located immediately east of the project site. The project site is currently characterized by flat and undeveloped desert landscape. One single-family residence is located approximately 450 feet to the west of the project site. The existing IID 161-kV "N" Line is located adjacent to Coachella Canal Road to the east of the project site.

Project Components

The proposed project consists of four primary components: 1) 50-megawatt (MW) photovoltaic (PV) energy generation facility; 2) 75-MW battery energy storage system (BESS); 3) on-site substation; and 4) off-site transmission line to connect to IID's existing 161-kV "N" Line. These four components together are collectively referred to as the "proposed project" or "project." These project components are described in detail below and depicted on Figure 3.

Solar Energy Facility

The proposed project involves the construction of a 50-MW alternating current (AC) PV solar energy facility. PV solar cells convert sunlight directly into direct current electricity. The process of converting light (photons) to electricity (voltage) in a solid-state process is called the photovoltaic effect. A number of individual PV cells are electrically arranged and connected into solar PV modules, sometimes referred to as solar panels.

The project proposes to utilize solar PV technology modules mounted on horizontal single-axis tracker (HSAT) systems with mounting racks supported by drive piles. The 50-MW solar energy field would consist of 110,250 modules on 3,675 strings and associated collector and inverter facilities.

The PV modules would rotate around the north-south HSAT axis so that the PV modules would continue to face the sun as the sun moves across the sky throughout the day. The PV modules would reach their maximum height (up to 9 feet above the ground, depending on the final design) at both sunrise and sunset, when the HSAT is rotated to point the modules at the rising or setting sun. At noon, or when stowed during high winds, when the HSAT system is rotated so that the PV modules are horizontal, the nominal height would be about 6 feet above the ground, depending on the final design.

The individual PV systems would be arranged in large arrays by placing them in columns spaced approximately 10 feet apart to maximize operational performance and to allow access for panel cleaning and maintenance. Current project designs would have individual HSAT PV modules, each approximately two feet wide by four feet long (depending on the specific PV technology selected), mounted on a frame which is attached to an HSAT system. The HSAT arrays would be separated from each other and the perimeter security fence by up to 30-foot-wide roads, consistent with Imperial County Fire Department emergency access requirements.

Battery Energy Storage System

As shown in Figure 3, a 75-MW BESS is proposed on an approximately 5-acre site within the northeast portion of the project site. The proposed BESS would consist of either lithium ion or flow batteries. The batteries will either be housed in storage containers or buildings fitted with HVAC and fire suppression systems as necessary, depending on the final selection of battery technology. Inside the housing the batteries will be placed on racks, the orientation of which depends on the type of housing. Underground trenches with conduits will be used to connect the batteries to the control and monitoring systems, and inverters to convert the PV produced DC power to AC power.

On-Site Substation

The dimensions of the proposed substation would be approximately 100 feet by 100 feet and would be located north of the BESS containers. The proposed substation would be unstaffed and automated. The California Building Code and the IEEE 693, Recommended Practices for Seismic Design of Substations, will be followed for the substation's design, structures, and equipment.

Off-Site Gen-tie Line

As shown in Figure 3, the project is proposed to connect to the electrical grid via an off-site transmission line, which would extend from the northeast corner of 003-110-005 and then east to the existing IID 161 kV "N" Line adjacent to Coachella Canal Road. The entire gen-tie alignment will be contained within IID's existing ROW.

Security

Six-foot high security fencing would be installed around the perimeter of the project site at the commencement of construction and site access would be limited to authorized site workers. In addition, a motion detection system and closed-circuit camera system may also be installed. The site would be remotely monitored 24 hours per day, 7 days per week. In addition, routine unscheduled security rounds may be made by the security team monitoring the site security.

Site Access

Highway 111 is approximately 2.6 miles west of the project site. Local unpaved roads would provide access to the project site from Highway 111. No new road crossings of any IID lateral canals or drains are proposed. The primary route for construction truck traffic would be via Coachella Canal Road, which intersects Highway 111 at Niland, Beal, and Cuff. Highway 111 is the primary route for northbound traffic from Calipatria and nearby communities with lodging. Southbound traffic bound from the Palm Springs area along Highway 111 would utilize Frink Road for site access. All construction traffic would utilize Coachella Canal Road for access to the project site.

To accommodate emergency access, PV panels would be spaced to maintain proper clearance. Internal access roads, up to 30-foot wide, would be constructed along the perimeter fence and solar panels to facilitate vehicle access and maneuverability for emergency unit vehicles.

Fire Protection/Fire Suppression

Fire protection systems for battery systems would be designed in accordance with the California Fire Code and would take into consideration the recommendations of the National Fire Protection Association (NFPA) 855.

Fire suppression agents such as Novec 1230 or FM 2000, or water may be used as a suppressant. In addition, fire prevention methods would be implemented to reduce potential fire risk, including voltage, current, and temperature alarms. Energy storage equipment would comply with Underwriters Laboratory (UL)-95401 and test methods associated with UL-9540A. The project would include lithium-ion batteries. For lithium-ion batteries storage, a system would be used that would contain the fire event and encourage suppression through cooling, isolation, and containment. Suppressing a lithium-ion (secondary) battery is best accomplished by cooling the burning material. A gaseous fire suppressant agent (e.g., 3M™ Novec™ 1230 Fire Protection Fluid or similar) and an automatic fire extinguishing system with sound and light alarms would be used for lithium-ion batteries.

To mitigate potential hazards, redundant separate methods of failure detection would be implemented. These would include alarms from the Battery Management System (BMS), including voltage, current, and temperature alarms. Detection methods for off gas detection would be implemented, as applicable. These are in addition to other potential protective measures such as ventilation, overcurrent protection, battery controls maintaining batteries within designated parameters, temperature and humidity controls, smoke detection, and maintenance in accordance with manufacturer guidelines. Remote alarms would be installed for operations personnel as well as emergency response teams in addition to exterior hazard lighting. In addition, an Incidence Response Plan would be implemented. Additionally, the project applicant would contribute its proportionate share for purchase of any fire-suppression equipment, if determined warranted by the County Fire Department for the proposed project.

Construction

Construction is anticipated to be completed in approximately 12 months. The following provides the proposed project's construction phases:

- Site Preparation
- Grading
- Building Construction

Dust generated during construction would be controlled by watering and, as necessary, the use of other dust suppression methods and materials accepted by the Imperial County Air Pollution Control District (ICAPCD).

A temporary, portable construction supply container would be located at the project site at the beginning of construction and removed at the end of construction. On-site parking would be provided for all construction workers.

Operations

Once fully constructed, the project would be operated on an unstaffed basis and be monitored remotely, with periodic on-site personnel visitations for security, maintenance and system monitoring. No full-time site personnel would be required on-site during operations. Any required planned maintenance activities would generally consist of equipment inspection and replacement and would be scheduled to avoid peak load periods. Any unplanned maintenance would be responded to as needed, depending on the event.

Water Use

Water demand for the proposed project will consist of water needed during construction and water needed for maintenance once the project is operational. Construction water demand is anticipated to be approximately 145 acre-feet (af) over the course of 12 months, thus, the monthly water demand during that period would average approximately 12 af. The operational water demand is anticipated to be 12.5 af per year (af/y). Maintenance activities are anticipated to be conducted up to twice a year over a one-to-two-week period each event, so the maintenance water demand is intermittent and not spread throughout the year. The operational demand will exist for the life of the project, which is anticipated to be 25 to 30 years. The project's water supply will be provided by a new onsite groundwater supply well to be drilled and installed as part of the project.

Restoration of the Project Site

Electricity generated by the project could be sold under the terms of a power purchase agreement (PPA) with a power purchaser (i.e., utility service provider). The projected life of the project is 25 to 30 years. At the end of the PPA term, the owner of the project may choose to enter into a subsequent PPA, update technology and re-commission, or decommission and remove the generating facility and its components. Upon decommissioning, the site could be converted to other uses in accordance with applicable land use regulations in effect at that time. A collection and recycling program will be executed to promote recycling of project components and minimize disposal in landfills. All permits related to decommissioning would be obtained, where required.

Project decommissioning may include the following activities:

- The facility would be disconnected from the utility power grid.
- Project components would be dismantled and removed using conventional construction equipment and recycled or disposed of safely.
- PV panel support steel and support posts would be removed and recycled off-site by an approved metals recycler.
- All compacted surfaces within the project site and temporary on-site haul roads would be de-compacted.
- Electrical and electronic devices, including inverters, transformers, panels, support structures, lighting fixtures, and their protective shelters would be recycled off-site by an approved recycler.
- All concrete used for the underground distribution system would be recycled off-site by a concrete recycler or crushed on-site and used as fill material.
- Fencing would be removed and recycled off-site by an approved metals recycler.
- Gravel roads would be removed; filter fabric would be bundled and disposed of in accordance with all applicable regulations. Road areas would be backfilled and restored to their natural contour.
- Soil erosion and sedimentation control measures would be re-implemented during the decommissioning period and until the site is stabilized.

Prior to issuance of the initial grading permit for the project, a Site Reclamation Plan in conformance with County of Imperial requirements would be prepared for review and approval by the Imperial County Planning and Development Services Department. This plan would be implemented at the end of power operations and would describe the proposed equipment dismantling, removal and site restoration program, in conformance with County requirements.

Project Approvals

Imperial County

The following are the primary discretionary approvals required for implementation of the project:

1. **Approval of Conditional Use Permit (CUP 23-0005).** Implementation of the project would require the approval of a CUP by the County to allow for the construction and operation of the proposed solar energy facility with an integrated battery storage system. The project parcels are currently zoned as S-2 and S-2-RE. Pursuant to Title 9, Division 5, Chapter 19, the following uses are permitted in the S-2 zone subject to approval of a CUP from Imperial County:

i) Major facilities relating to the generation and transmission of electrical energy provide[d] such facilities are not under State or Federal law, to [be] approved exclusively by an agency, or agencies of the State or Federal government, and provided such facilities shall be approved subsequent to coordination review of the Imperial Irrigation District for electrical matters. Such uses shall include but be limited to the following:

- *Electrical generation plants*

- *Facilities for the transmission of electrical energy (100-200 kV)*
 - *Electrical substations in an electrical transmission system (500 kv/230 kv/161 kV)*
2. **Approval of CUP (CUP 23-0006) – Groundwater Well.** Pursuant to Title 9 Division 21: Water Well Regulations, §92102.00, the applicant will be required to obtain a CUP for the proposed on-site groundwater well. As required by §92102.00, no person shall (1) drill a new well, (2) activate a previously drilled but unused well, (unused shall mean a well or wells that have not been used for a 12 month) period by installing pumps, motors, pressure tanks, piping, or other equipment necessary or intended to make the well operational, (3) increase the pumping capacity of a well, or (4) change the use of a well, without first obtaining a CUP through the County Planning & Development Services Department.
 3. **General Plan Amendment (#23-0001).** An amendment to the County’s General Plan, Renewable Energy and Transmission Element is required to implement the proposed project. CUP applications proposed for specific renewable energy projects not located in the Renewable Energy (RE) Overlay Zone would not be allowed without an amendment to the RE Overlay Zone. Of the two parcels that comprise the project site, APN 003-110-005 is within the County’s RE Overlay Zone; however, APN 003-110-007 is outside of the RE Overlay Zone. One of the two parcels that comprise the project site is located outside of the RE Overlay Zone (APN 003-110-007). Therefore, the applicant is requesting a General Plan Amendment to include/classify APN 003-110-007 into the RE Overlay Zone. The underlying “Agriculture” General Plan designation would remain.
 4. **Zone Change (#23-0001).** The applicant is requesting a zone change to include/classify APN 003-110-007) into the RE Overlay Zone (i.e., zone change from S-2 to S-2-RE).

Figure 1. Regional Location

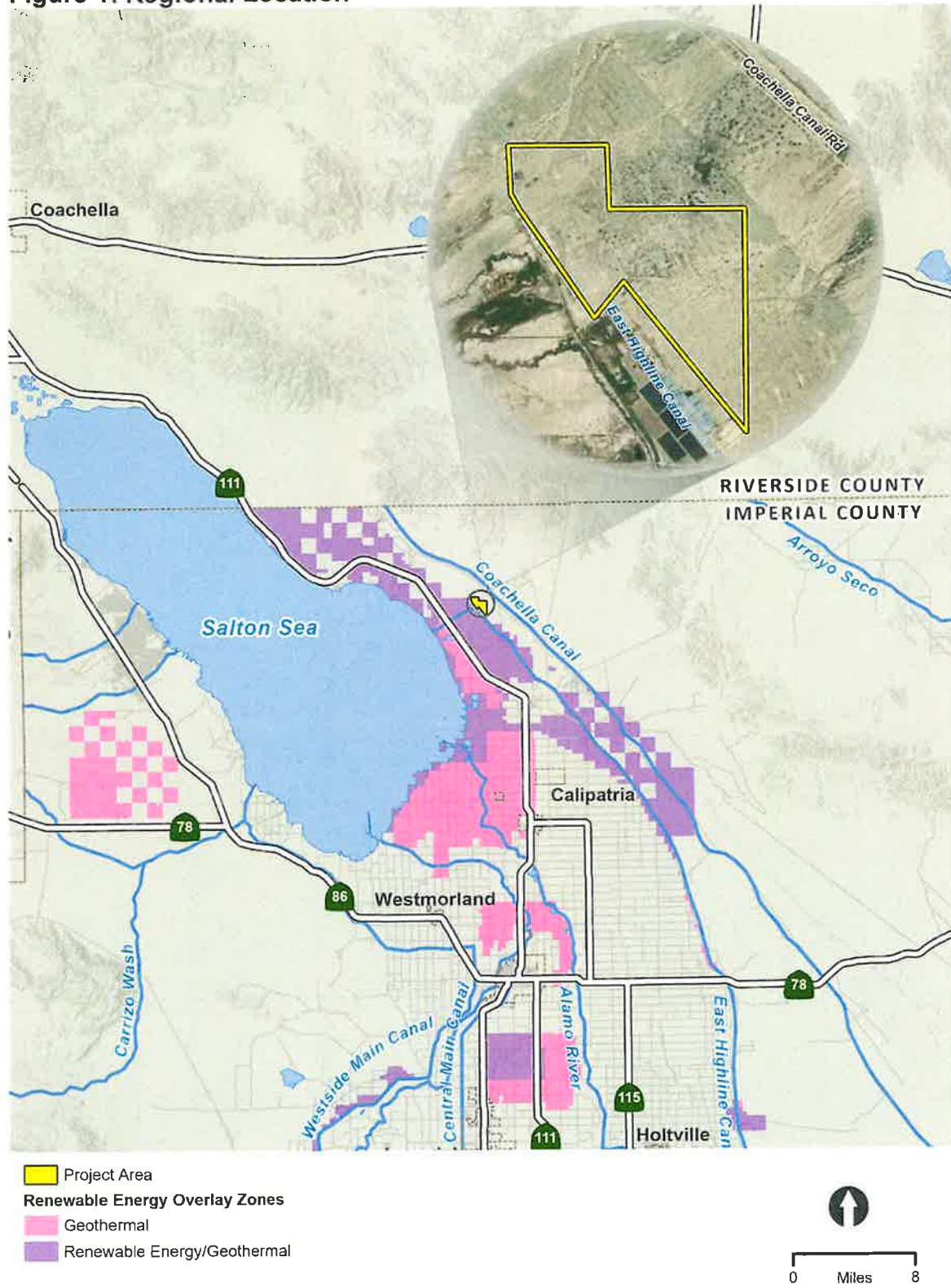
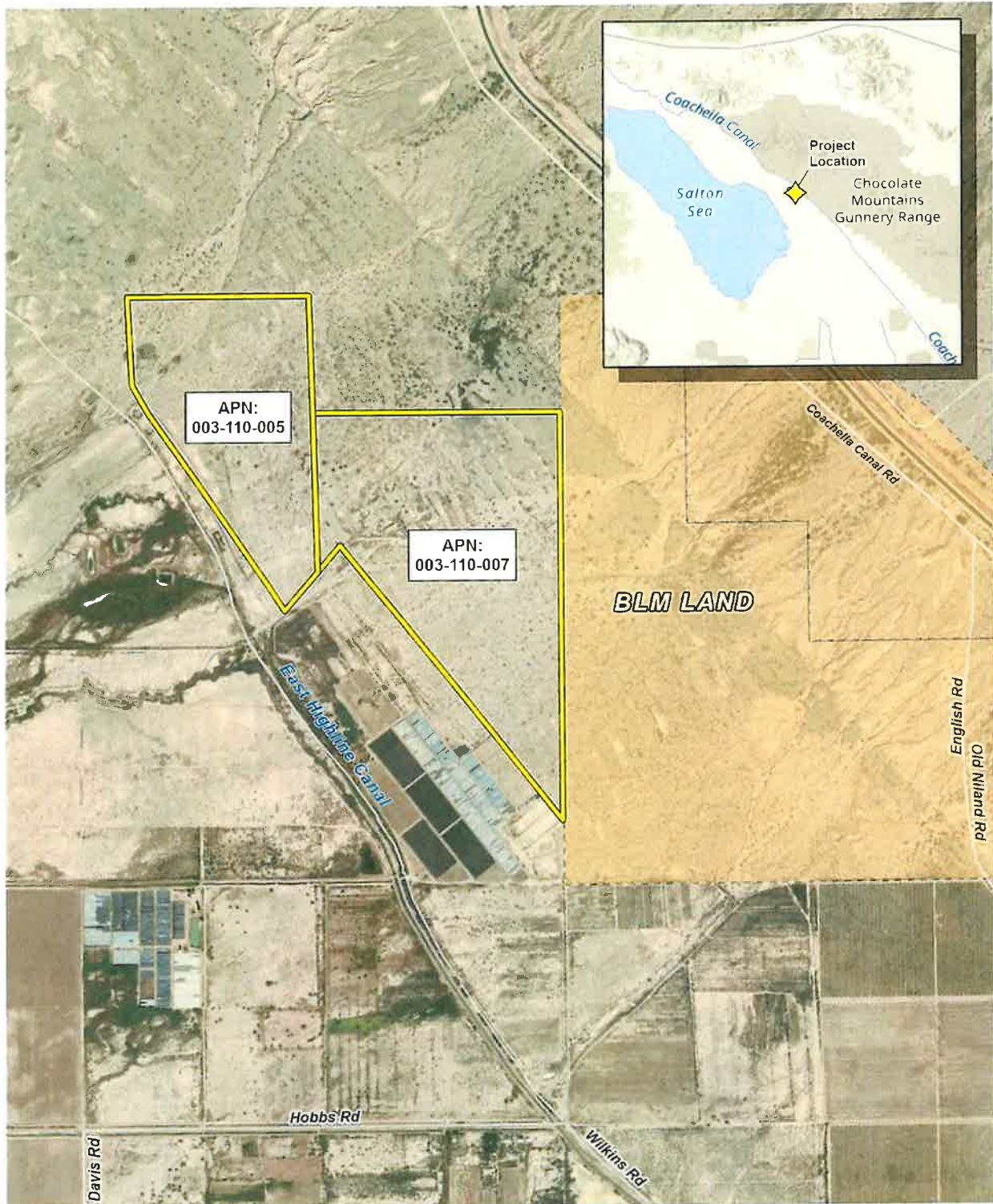



Figure 2. Project Vicinity



-  North Star 1 Project Parcels
-  BLM Land



0 0.3 mi

Figure 3. Project Components

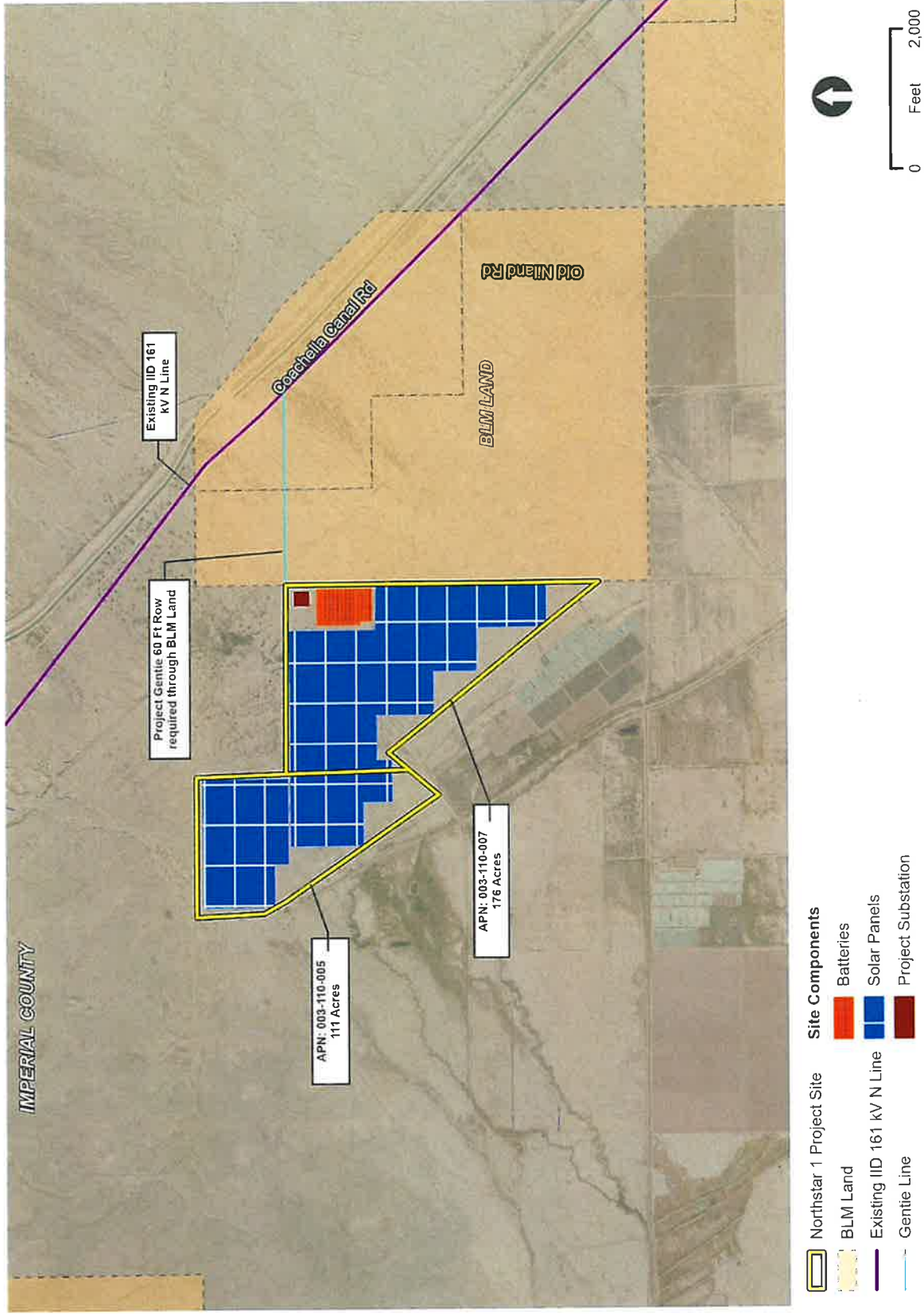



This page is intentionally blank.

Evaluation of Environmental Impacts

1. A brief explanation is required for all answers except "No Impact" answers that are adequately supported by the information sources a lead agency cites in the parentheses following each question. A "No Impact" answer is adequately supported if the referenced information sources show that the impact simply does not apply to projects like the one involved (e.g., the project falls outside a fault rupture zone). A "No Impact" answer should be explained where it is based on project-specific factors, as well as general standards (e.g., the project will not expose sensitive receptors to pollutants, based on a project-specific screening analysis).
2. All answers must take account of the whole action involved, including off-site as well as on-site, cumulative as well as project-level, indirect as well as direct, and construction as well as operational impacts.
3. Once the lead agency has determined that a particular physical impact may occur, then the checklist answers must indicate whether the impact is potentially significant, less than significant with mitigation, or less than significant. "Potentially Significant Impact" is appropriate if there is substantial evidence that an effect may be significant. If there are one or more "Potentially Significant Impact" entries when the determination is made, an EIR is required.
4. "Negative Declaration: Less Than Significant With Mitigation Incorporated" applies where the incorporation of mitigation measures has reduced an effect from "Potentially Significant Impact" to a "Less Than Significant Impact." The lead agency must describe the mitigation measures, and briefly explain how they reduce the effect to a less than significant level (mitigation measures from "Earlier Analyses," as described in (5) below, may be cross-referenced).
5. Earlier analyses may be used where, pursuant to the tiering, program EIR, or other CEQA process, an effect has been adequately analyzed in an earlier EIR or negative declaration. Section 15063(c)(3)(D). In this case, a brief discussion should identify the following:
 - a. Earlier Analysis Used. Identify and state where they are available for review.
 - b. Impacts Adequately Addressed. Identify which effects from the above checklist were within the scope of and adequately analyzed in an earlier document pursuant to applicable legal standards, and state whether such effects were addressed by mitigation measures based on the earlier analysis.
 - c. Mitigation Measures. For effects that are "Less than Significant with Mitigation Measures Incorporated," describe the mitigation measures which were incorporated or refined from the earlier document and the extent to which they address site-specific conditions for the project.

6. Lead agencies are encouraged to incorporate into the checklist references to information sources for potential impacts (e.g., general plans, zoning ordinances). Reference to a previously prepared or outside document should, where appropriate, include a reference to the page or pages where the statement is substantiated.
7. Supporting Information Sources: A source list should be attached, and other sources used, or individuals contacted should be cited in the discussion.
8. This is only a suggested form, and lead agencies are free to use different formats; however, lead agencies should normally address the questions from this checklist that are relevant to a project's environmental effects in whatever format is selected.
9. The explanation of each issue should identify:
 - a. The significance criteria or threshold, if any, used to evaluate each question; and
 - b. The mitigation measure identified, if any, to reduce the impact to less than significance.



I. Aesthetics

Environmental Issue Area:	Potentially Significant Impact	Less than Significant with Mitigation Incorporated	Less Than Significant Impact	No Impact
Except as provided in Public Resources Code Section 21099, would the project:				
a) Have a substantial adverse effect on a scenic vista?	<input type="checkbox"/>	<input type="checkbox"/>	<input type="checkbox"/>	<input checked="" type="checkbox"/>
b) Substantially damage scenic resources, including, but not limited to, trees, rock outcroppings, and historic building within a state scenic highway?	<input type="checkbox"/>	<input type="checkbox"/>	<input checked="" type="checkbox"/>	<input type="checkbox"/>
c) In non-urbanized areas, substantially degrade the existing visual character or quality of public views of the site and its surroundings? (Public views are those that are experienced from publicly accessible vantage points). If the project is in an urbanized area, would the project conflict with applicable zoning and other regulations governing scenic quality?	<input type="checkbox"/>	<input type="checkbox"/>	<input checked="" type="checkbox"/>	<input type="checkbox"/>
d) Create a new source of substantial light or glare which would adversely affect day or nighttime views in the area?	<input type="checkbox"/>	<input type="checkbox"/>	<input checked="" type="checkbox"/>	<input type="checkbox"/>

Impact Analysis

The following information is summarized from the Visual Resources Impact Assessment prepared by ECORP Consulting, Inc. (ECORP). This report is provided as Appendix A of this Initial Study.

- a) **No Impact.** According to the *Visual Resources Impact Assessment*, there are no designated scenic vistas in the vicinity of the project site (Appendix A of this Initial Study). Therefore, the proposed project would not have a substantial adverse effect on a scenic vista and no impact is identified.
- b) **Less than Significant Impact.** There are no designated or eligible scenic highways in the vicinity of the project site. According to the Conservation and Open Space Element, no State scenic highways have been designated in Imperial County (County of Imperial 2016). The project site is not located within a state scenic highway corridor. The nearest road segment considered eligible for a State scenic highway designation is the portion of Highway 111 along the northeast shore of the Salton Sea from Bombay Beach to the County line (County of Imperial 2016). The project site is located over 8 miles south of this section of Highway 111; therefore, the project site would not be visible from Highway 111. No impacts to scenic resources within any state scenic highways would occur. This would be considered a less than significant impact.
- c) **Less than Significant Impact.** The overall character of the immediate landscape is natural open space to the north, west, and east and agricultural to the south. The most notable features in the landscape are the ranges in the background to the north and the east of the

project site. The dark grey, subdued formations of the Chocolate Mountains, approximately 2.5 miles to the east of the project site are approximately 2,000 feet above mean sea level and are visible along the horizon from the site.

With the additions of the solar facility and BESS storage containers, the existing natural landscape would result in a change in contrast, but the project site is generally not visible from nearby roads or residences. Based on the viewshed analysis for the project, viewers in the area (drivers on local roads) would not see the proposed project. In addition, the lifespan of the project is 25 to 30 years, with full restoration after closure which would address the change in contrast from the proposed project in the long-term (Appendix A of this Initial Study).

The existing natural landscape is a valued resource because of its unspoiled natural and unspoiled nature and panoramic view, especially because of the mountains in the background, which can be seen by motorists along Coachella Canal Road. The foreground view, consisting of comparatively monotonous desert scrub habitat, is less valued because of the lack of distinguishing or interesting features, as evidenced by the lack of turnouts allowing motorists to stop and enjoy the view at the project site.

One key observation point (KOP) was identified to assess the level of visual change resulting from the proposed project on the existing environment. KOP 1 is the view from Coachella Canal Road located east of the project site and looking westward. The proposed project would be perceivable from this KOP based on viewer perspective (Figure 4). With the addition of structures (e.g., solar arrays, gen-tie line) to an area where there are currently none, the change in contrast in the foreground is strong. However, other than the proposed transmission gen-tie line that is visible from this KOP, the project site is generally not visible from nearby roads or residences, and therefore, the contrast associated with the introduction of the gen-tie line is considered to be weak.

Sensitive viewers at the KOP include those traveling north and south on Coachella Canal Road who would therefore experience an impact to visual resources because of the proposed project. However, impacts to the sensitive receptors from the proposed project would be temporary because viewers at from the KOP would not be stationary. Travelers on Coachella Canal Road would pass the solar arrays for the proposed project within 1 minute and then be back to the existing desert and panoramic view. Therefore, the proposed project would result in a less than significant impact to the existing visual character or quality of the site and its surroundings.

- d) **Less than Significant Impact.** The Project would not include any substantial source of nighttime light in the vicinity of the Project site. Any lighting required for safety and security within the Project site would be hooded and oriented downward so as not to spill over into adjacent parcels consistent with Title 9, Division 17, Chapter 2: Specific Standards for all Renewable Energy Projects, of the County's Zoning Ordinance.

A glare analysis was conducted to determine the potential for significant glint or glare from solar panels and other built-project components that may affect residents and motorists. The glare analysis shows two receptors with the potential to receive glare from the proposed project:

- Motorists traveling northwest on Wilkins Road, in the vicinity of the proposed project, may experience 2.6 hours of medium glare between 6:00 and 7:00 am, mid-February to Mid-April and September to mid-December, when the modules are fully rotated to the east and west, respectively.
- From a stationary observation point just west of the midpoint of the western boundary of the proposed project, may experience up to 13.8 hours of medium glare between 5:00 and 7:00 am, throughout the year, when the modules are fully rotated to the west.



The glare analysis for the proposed project concluded that because Wilkins Road is lightly travelled, glare exposure would be minimal. Workers on-site may experience momentary and temporary glare while conducting construction activities. However, given that few people would regularly experience glint or glare, effects are considered less than significant.



This page is intentionally blank.

Figure 4. View from KOP 1



Source: Appendix A of this Initial Study



This page is intentionally blank.

II. Agriculture and Forestry Resources

Environmental Issue Area:	Potentially Significant Impact	Less than Significant with Mitigation Incorporated	Less Than Significant Impact	No Impact
<p><i>In determining whether impacts to agricultural resources are significant environmental effects, lead agencies may refer to the California Agricultural Land Evaluation and Site Assessment Model (1997) prepared by the California Department of Conservation as an optional model to use in assessing impacts on agriculture and farmland. In determining whether impacts to forest resources, including timberland, are significant environmental effects, lead agencies may refer to information compiled by the California Department of Forestry and Fire Protection regarding the state's inventory of forest land, including the Forest and Range Assessment Project and the Forest Legacy Assessment project; and forest carbon measurement methodology provided in Forest Protocols adopted by the California Air Resources Board. Would the project:</i></p>				
a) Convert Prime Farmland, Unique Farmland, or Farmland of Statewide Importance (Farmland), as shown on the maps prepared pursuant to the Farmland Mapping and Monitoring Program of the California Resources Agency, to non-agricultural use?	<input type="checkbox"/>	<input type="checkbox"/>	<input type="checkbox"/>	<input checked="" type="checkbox"/>
b) Conflict with existing zoning for agricultural use, or a Williamson Act contract?	<input type="checkbox"/>	<input type="checkbox"/>	<input type="checkbox"/>	<input checked="" type="checkbox"/>
c) Conflict with existing zoning for, or cause rezoning of, forest land (as defined in Public Resources Code section 12220(g)), timberland (as defined by Public Resources Code section 4526), or timberland zoned Timberland Production (as defined by Government Code section 51104(g))?	<input type="checkbox"/>	<input type="checkbox"/>	<input type="checkbox"/>	<input checked="" type="checkbox"/>
d) Result in the loss of forest land or conversion of forest land to non-forest use?	<input type="checkbox"/>	<input type="checkbox"/>	<input type="checkbox"/>	<input checked="" type="checkbox"/>
e) Involve other changes in the existing environment which, due to their location or nature, could result in conversion of Farmland, to non-agricultural use or conversion of forest land to non-forest use?	<input type="checkbox"/>	<input type="checkbox"/>	<input type="checkbox"/>	<input checked="" type="checkbox"/>

Impact Analysis

- a) **No Impact.** According to the California Department of Conservation's (DOC) California Important Farmland Finder, the project site is not located on land designated as Prime Farmland, Unique Farmland, or Farmland of Statewide Importance (California DOC 2023). The project site is designated as Other Land by the DOC. Therefore, the proposed project would not convert Prime Farmland, Unique Farmland, or Farmland of Statewide Importance to non-agricultural use and no impact is identified.

- b) **No Impact.** The project site is currently zoned S-2 (Open Space/Preservation) and S-2-RE (Open Space/Preservation in Renewable Energy Zone) and is not zoned for agricultural use. Therefore, the proposed project would not conflict with existing zoning for agricultural use and no impact is identified.

As of December 31, 2018, all Williamson Act contracts in Imperial County have been terminated. The project site is not located on Williamson Act contracted land. Therefore, the proposed project would not conflict with a Williamson Act contract and no impact is identified.

- c) **No Impact.** The project site is not located on forest land as defined in PRC Section 1220 (g). There are no existing forest lands, timberlands, or timberland zoned Timberland Production either on-site or in the immediate vicinity; therefore, the project would not conflict with existing zoning of forest land or cause rezoning of any forest land. Additionally, the site is not zoned as forest, timberland or for Timberland Production. Therefore, no impact is identified for this issue area.
- d) **No Impact.** There are no existing forest lands either on site or in the immediate vicinity of the project site. The proposed project would not result in the loss of forest land or conversion of forest land to non-forest use. Therefore, no impact is identified for this issue area.
- e) **No Impact.** As discussed in Response II. a) above, the project site is not located on land designated as Important Farmland and would not convert farmland to non-agriculture use. As discussed in Response II. d) above, there are no existing forest lands either on site or in the immediate vicinity of the project site. Therefore, the proposed project would not result in the conversion of forest land to non-forest use. Thus, no impact is identified for this issue area.

III. Air Quality

Environmental Issue Area:	Potentially Significant Impact	Less than Significant with Mitigation Incorporated	Less Than Significant Impact	No Impact
<i>Where available, the significance criteria established by the applicable air quality management district or air pollution control district may be relied upon to make the following determinations.</i>				
<i>Would the project:</i>				
a) Conflict with or obstruct implementation of the applicable air quality plan?	<input type="checkbox"/>	<input checked="" type="checkbox"/>	<input type="checkbox"/>	<input type="checkbox"/>
b) Result in a cumulatively considerable net increase of any criteria pollutant for which the project region is non-attainment under an applicable federal or state ambient air quality standard?	<input type="checkbox"/>	<input checked="" type="checkbox"/>	<input type="checkbox"/>	<input type="checkbox"/>
c) Expose sensitive receptors to substantial pollutant concentrations?	<input type="checkbox"/>	<input type="checkbox"/>	<input checked="" type="checkbox"/>	<input type="checkbox"/>
d) Result in other emissions (such as those leading to odors adversely affecting a substantial number of people)?	<input type="checkbox"/>	<input type="checkbox"/>	<input checked="" type="checkbox"/>	<input type="checkbox"/>

Impact Analysis

The following information is summarized from the *Air Quality and Greenhouse Gas Emissions Assessment* prepared by ECORP Consulting, Inc. (ECORP). This report is provided as Appendix B of this Initial Study.

- a) **Less than Significant with Mitigation Incorporated.** The proposed project is located within the jurisdiction of the Imperial County Air Pollution Control District (ICAPCD) in the Salton Sea Air Basin. The project region is designated as a nonattainment area for the federal ozone (O₃), particulate matter less than 2.5 microns in diameter (PM_{2.5}) and particulate matter less than 10 microns in diameter (PM₁₀) standards and is also a nonattainment area for the state standards for O₃ and PM₁₀.

The U.S. Environmental Protection Agency, under the provisions of the Clean Air Act, requires each state with regions that have not attained the federal air quality standards to prepare a State Implementation Plan (SIP), detailing how these standards are to be met in each local area.

The region's SIP is constituted of the following ICAPCD air quality plans: 2018 PM₁₀ SIP, the 2018 Annual PM_{2.5} SIP, the 2017 8-Hour Ozone SIP, 2013 24-Hour PM_{2.5} SIP, the 2009 1997 8-hour Ozone RACT SIP, the 2009 PM₁₀ SIP and the 2008 Ozone Early Progress Plans. Conformance with the Air Quality Management Plan (AQMP) for development projects is determined by demonstrating compliance with local land use plans and/or population projections, meeting the land use designation set forth in the local General Plan, and comparing assumed emissions in the AQMP to proposed emissions. The project must demonstrate compliance with all ICAPCD applicable rules and regulations, as well as local land use plans and population projections. As the project does not contain a residential component, the project would not result in an increase in the regional population. While the project would contribute to energy supply, which is one factor of population growth, the proposed project would not significantly increase employment or growth within the region. The proposed project would be required to comply with all applicable ICAPCD rules and requirements during construction and operation to reduce air emissions. Overall, the proposed project would improve air quality by reducing the amount of emissions that would be generated in association with electricity production from a fossil fuel burning facility. Furthermore, the thresholds of significance, adopted by the air district (ICAPCD), determine compliance with the goals of the attainment plans in the region. As such, emissions below the ICAPCD regional mass daily emissions thresholds presented would not conflict with or obstruct implementation of the applicable air quality plans.

The following provides an analysis of potential impacts during construction of the project followed by an analysis of potential impacts during operation of the project.

Construction

Air quality impacts related to construction were calculated using the CalEEMod 2020.4.0 air quality model. CalEEMod is a statewide land use emissions computer model designed to quantify potential criteria pollutant emissions associated with both construction and operations from a variety of land use projects. Project construction-generated air pollutant emissions were calculated using CalEEMod model defaults for Imperial County. The project's construction assumptions used in the CalEEMod, including construction schedule and equipment mix, are described in the project's air quality and greenhouse gas assessment (Appendix B of this Initial Study).

The ICAPCD requires that, regardless of the size of a project, all feasible standard measures for fugitive PM₁₀ must be implemented at construction sites. Additionally, all feasible discretionary measures for PM₁₀ apply to those construction sites that are five acres or more for non-residential developments or 10 acres or more in size for residential developments. Standard and discretionary measures from the ICAPCD handbook include:

Standard Measures for Fugitive PM₁₀ Control:

- a. All disturbed areas, including bulk material storage which is not being actively utilized, shall be effectively stabilized and visible emissions shall be limited to no greater than 20 percent opacity for dust emissions by using water, chemical stabilizers, dust suppressants, tarps or other suitable material such as vegetative ground cover.
- b. All on-site and off-site unpaved roads will be effectively stabilized and visible emissions shall be limited to no greater than 20 percent opacity for dust emissions by paving, chemical stabilizers, dust suppressants and/or watering.
- c. All unpaved traffic areas one acre or more with 75 or more average vehicle trips per day will be effectively stabilized and visible emission shall be limited to no greater than 20 percent opacity for dust emissions by paving, chemical stabilizers, dust suppressants and/or watering. The transport of bulk materials shall be completely covered unless six inches of freeboard space from the top of the container is maintained with no spillage and loss of bulk material. In addition, the cargo compartment of all haul trucks is to be cleaned and/or washed at delivery site after removal of bulk material.
- d. The transport of bulk materials shall be completely covered unless six inches of freeboard space from the top of the container is maintained with no spillage and loss of bulk material. In addition, the cargo compartment of all haul trucks is to be cleaned bulk material.
- e. All track-out or carry-out will be cleaned at the end of each workday or immediately when mud or dirt extends a cumulative distance of 50 linear feet or more onto a paved road within an urban area.
- f. Movement of bulk material handling or transfer shall be stabilized prior to handling or at points of transfer with application of sufficient water, chemical stabilizers or by sheltering or enclosing the operation and transfer line.
- g. The construction of any new unpaved road is prohibited within any area with a population of 500 or more unless the road meets the definition of a temporary unpaved road. Any temporary unpaved road shall be effectively stabilized and visible emissions shall be limited to no greater than 20 percent opacity for dust emission by paving, chemical stabilizers, dust suppressants and/or watering.

Discretionary Measures for Fugitive PM₁₀ Control

- a. Water exposed soil with adequate frequency for continued moist soil.
- b. Replace ground cover in disturbed areas as quickly as possible.
- c. Automatic sprinkler system installed on all soil piles.
- d. Vehicle speed for all construction vehicles shall not exceed 15 mph on any unpaved surface at the construction site.
- e. Develop a trip reduction plan to achieve a 1.5 average vehicle ridership for construction employees.
- f. Implement a shuttle service to and from retail services and food establishments during lunch hours.

The ICAPCD requires that, regardless of the size of a project, all feasible standard measures for construction equipment must be implemented at construction sites. Standard measures from the ICAPCD handbook include:

Standard Measures for Construction Combustion Equipment

- a. Use of alternative fueled or catalyst equipped diesel construction equipment, including all off-road and portable diesel-powered equipment.

- b. Minimize idling time either by shutting equipment off when not in use or reducing the time of idling to five minutes as a maximum.
- c. Limit, to the extent feasible, the hours of operation of heavy-duty equipment and/or the amount of equipment in use.
- d. Replace fossil fueled equipment with electrically driven equivalents (provided they are not run via a portable generator set).

Construction-related Emissions. Construction-related activities are temporary, short-term sources of air pollutant emissions. Two basic sources of short-term emissions would be generated through project implementation: operation of heavy-duty equipment (i.e., excavators, loaders, haul trucks) and the creation of fugitive dust during clearing and grading. Construction activities such as excavation and grading operations, construction vehicle traffic, and wind blowing over exposed soils would generate exhaust emissions and fugitive PM emissions that affect local air quality at various times during construction (Appendix B of this Initial Study).

Predicted maximum daily emissions attributable to project construction, which includes implementation of ICAPCD’s Regulation VIII emission-reduction measures, are summarized in Table 1. As shown in Table 1, the proposed project would not exceed ICAPCD’s construction-related criteria pollutant thresholds for ROG, NO_x, CO, SO₂, and PM_{2.5}. However, as shown in Table 1, emissions of PM₁₀ would exceed the ICAPCD significance threshold even with the implementation of ICAPCD Regulation VIII emission-reduction measures applied on the project site. Regulation VIII requires that all unpaved roadways, both on- and off-site, to be conditioned and maintained with soil stabilizers to reduce dust opacity to no more than 20 percent; all unpaved disturbed surfaces, both on- and off-site, to be stabilized with a dust suppressant, watering, or soil stabilizers to reduce opacity to no greater than 20 percent; and to reduce vehicle speed to no greater than 15 mph on all unpaved surfaces. Commute vehicles traveling over the exposed soils of unpaved roads generates substantial amounts of fugitive PM₁₀ emissions. The majority of roadways leading to the project site are paved; however, the last 1.15 miles of the project site access route, beginning with a dirt road traversing north from Hobbs Road, is an unpaved roadway. Mitigation Measure AQ-1 would reduce PM₁₀ emissions to levels below the ICAPCD significance threshold by stabilizing fugitive dust on the unpaved access route from Hobbs Road to the project site. As shown in Table 2, emissions generated by construction would not exceed the ICAPCD’s thresholds of significance with implementation of Mitigation Measure AQ-1, and this impact would be reduced to a level less than significant.

Table 1. Unmitigated Project Construction-Generated Emissions

Construction Year	Pollutant (Pounds Per Day)					
	ROG	NO _x	CO	SO ₂	PM ₁₀	PM _{2.5}
Construction Year One	7.29	61.05	72.83	0.17	273.39	29.96
Construction Year Two	7.00	45.91	70.87	0.17	273.23	29.82
ICAPCD Significance Threshold	75	100	550	N/A	150	N/A
Exceed ICAPCD Threshold?	No	No	No	No	Yes	No

Source: Appendix B of this Initial Study

Table 2. Mitigated Project Construction-Generated Emissions

Construction Year	Pollutant (Pounds Per Day)					
	ROG	NO _x	CO	SO ₂	PM ₁₀	PM _{2.5}
Construction Year One	7.29	61.05	72.83	0.17	11.48	5.87
Construction Year Two	7.00	45.91	70.87	0.17	7.74	3.35
ICAPCD Significance Threshold	75	100	550	N/A	150	N/A
Exceed ICAPCD Threshold?	No	No	No	No	No	No

Source: Appendix B of this Initial Study

CUP Conditions of Approval for ICAPCD Review/Compliance (Construction):

As a Condition(s) of Approval of the CUP, the applicant will be required to submit information to ICAPCD to verify that proper emissions controls have been implemented to maintain air emissions below ICAPCD Significance Thresholds. These CUP Conditions of Approval include for the construction phase:

- As a CUP Condition of Approval, the applicant shall submit an Enhanced Construction Dust Control Plan to the ICAPCD for review and approval.
- As a CUP Condition of Approval, the applicant shall submit an Equipment List to ICAPCD. The Equipment List shall be submitted periodically (on a monthly basis) during construction and include the following:
 - The list must be in Excel Format and include make, model, year, ID/serial number(s), type, tier, horsepower, and actual dates and hours used.
 - The Equipment List shall be submitted to ICAPCD electronically on a monthly basis
 - The ICAPCD will calculate NO_x emissions using the Equipment Lists once construction is completed to verify that NO_x thresholds were not exceeded. In the event an exceedance is determined the project may become subject to Policy 5 requirements.

Operation

Operation-related sources of air pollutant emissions include the direct emission of criteria pollutants. Although limited, implementation of the proposed project would result in long-term operational emissions of criteria air pollutants such as PM₁₀, PM_{2.5}, CO, and SO₂ as well as O₃ precursors such as ROG and NO_x. Project-generated increases in emissions would be predominantly associated with motor vehicle use for routine maintenance work, site security, and trucking in water. Long-term operational emissions attributable to the project are identified in Table 3 and compared to the operational significance thresholds from ICAPCD. As shown in Table 3, the project’s emissions would not exceed any ICAPCD thresholds for any criteria air pollutants during operation, and operations-related emissions would be less than significant for the proposed project.



Table 3. Operational-Related Emissions (Regional Significance Analysis)

Emission Source	Pollutants (pounds per day)					
	ROG	NO _x	CO	SO ₂	PM ₁₀	PM _{2.5}
Summer Emissions						
Area	5.86	0.00	0.02	0.00	0.00	0.00
Energy	0.00	0.00	0.00	0.00	0.00	0.00
Mobile	0.01	0.77	0.17	0.00	3.54	0.36
Total	5.87	0.77	0.19	0.00	3.54	0.36
<i>ICAPCD Significance Threshold</i>	137	137	150	550	550	150
Exceed ICAPCD Threshold?	No	No	No	No	No	No
Winter Emissions						
Area	5.86	0.00	0.02	0.00	0.00	0.00
Energy	0.00	0.00	0.00	0.00	0.00	0.00
Mobile	0.01	0.85	0.15	0.00	3.54	0.39
Total	5.87	0.85	0.17	0.00	3.54	0.39
<i>ICAPCD Significance Threshold</i>	137	137	150	550	550	150
Exceed ICAPCD Threshold?	No	No	No	No	No	No

Source: Appendix B of this Initial Study

Conclusion

As described above, conformance with the AQMP for development projects is determined by demonstrating compliance with local land use plans and/or population projections and comparing assumed emissions in the AQMP to proposed emissions. Because the proposed project complies with local land use plans and population projections and would not exceed ICAPCD’s thresholds during construction (with implementation of Mitigation Measure AQ-1) and operations, the proposed project would not conflict with or obstruct implementation of the applicable air quality plan. Therefore, this is considered a less than significant impact.

Mitigation Measure:

AQ-1 During construction activities, the construction contractor shall employ the following PM₁₀ reducing measures:

- Adhere to the Imperial County Air Pollution Control District’s Regulation VIII requirements on the project site during construction.
- The entire unpaved access route from Hobbs Road to the project site shall be effectively stabilized and visible emissions shall be limited to no greater than 20 percent opacity.
- All vehicles accessing the project site on unpaved roads shall be limited to a speed of 15 miles per hour.

The Planning and Development Services Department and ICAPCD shall verify implementation of this measure.

b) **Less than Significant with Mitigation Incorporated.** By its very nature, air pollution is largely a cumulative impact. No single project is sufficient in size, by itself, to result in nonattainment of ambient air quality standards. Instead, a project’s individual emissions

contribute to existing cumulatively significant adverse air quality impacts. If a project's individual emissions exceed its identified significance thresholds, the project would be cumulatively considerable. Projects that do not exceed significance thresholds would not be considered cumulative considerable.

The ICAPCD's application of thresholds of significance for criteria air pollutants is relevant to the determination of whether a project's individual emissions would have a cumulatively significant impact on air quality. As discussed above in Response III. a), with implementation of Mitigation Measure AQ-1, emissions generated by construction would not exceed the ICAPCD's thresholds of significance with implementation of Mitigation Measure AQ-1 (Table 2). As shown in Table 3, operation of the project would result in minimal emissions that would be less than the applicable thresholds for all criteria pollutants. Therefore, project construction and operations would not result in a cumulatively considerable net increase in emissions of ozone, PM₁₀, or PM_{2.5}, and impacts would be considered less than significant.

- c) **Less than Significant Impact.** The project site is surrounded by vacant desert land to the west, north, and east and agricultural land to the south. The nearest single-family residence is located approximately 450 feet from the western boundary of the project site.

Construction-Generated Air Contaminants. Construction of the project and associated infrastructure would result in short-term project-generated emissions of diesel particulate matter (DPM), ROG, NO_x, CO, and PM₁₀ from the exhaust of off-road, heavy-duty diesel equipment, soil hauling truck traffic, paving, and other construction activities. Generation of DPM from construction projects typically occurs in a single area for a short period. Construction is anticipated to last for approximately one year. As previously described, existing O₃ and PM₁₀ levels in the SSAB are at unhealthy levels during certain periods. However, as shown in Table 2, the project would not exceed the ICAPCD significance thresholds for construction emissions with implementation of Mitigation Measure AQ-1.

In addition, the project is not anticipated to substantially contribute to regional O₃ and CO concentrations and the associated health impacts with these pollutants. As with O₃ and NO_x, the project would not generate emissions of PM₁₀ or PM_{2.5} that would exceed the ICAPCD's thresholds with implementation of Mitigation Measure AQ-1. Accordingly, the project's PM₁₀ and PM_{2.5} emissions are not expected to cause any increase in related regional health effects for these pollutants. Therefore, project construction would not result in a potentially significant contribution to regional concentrations of nonattainment pollutants and would result in a significant contribution to adverse health effects.

Therefore, the proposed project would not expose sensitive receptors to substantial pollutant concentrations during construction, and impacts would be less than significant.

Operational Air Contaminants. As discussed above in Response III. a), the criteria pollutant emissions have been calculated for operational activities, which were found to be within the ICAPCD's allowable operational thresholds. Operation of the proposed project would not result in the development of any substantial sources of air toxins. There would be no stationary sources associated with project operations; nor would the project attract additional mobile sources that spend long periods queuing or idling on-site. On-site project emissions would not result in significant concentrations of pollutants at the nearby sensitive receptor as the predominant operational emissions associated with the proposed project would be routine maintenance work, water deliveries, and site security. Therefore, the project would not be a substantial source of TACs or result in a high carcinogenic or non-carcinogenic risk during operations.

Carbon Monoxide Hot Spots. CO exceedances are caused by vehicular emissions, primarily when idling at intersections. Concentrations of CO are a direct function of the number of vehicles, length of delay, and traffic flow conditions. Under certain meteorological conditions, CO concentrations close to congested intersections that experience high levels of traffic and elevated background concentrations may reach unhealthy levels, affecting nearby sensitive receptors. Given the high traffic volume potential, areas of high CO



concentrations, or “hot spots,” are typically associated with intersections that are projected to operate at unacceptable levels of service during the peak commute hours. CO concentration in the SSAB is designated as an attainment area. Detailed modeling of project-specific CO “hot spots” is not necessary and thus this potential impact is addressed qualitatively.

The proposed project is anticipated to result in no more than four daily traffic trips. It is noted that this is a conservative estimate, and many days will have no operational related vehicle trips. Thus, the proposed project would not generate traffic volumes at any intersection of more than 100,000 vehicles per day (or 44,000 vehicles per day) and there is no likelihood of the project traffic exceeding CO values. Therefore, this is considered less than significant.

- d) **Less than Significant Impact.** During construction, the proposed project presents the potential for generation of objectionable odors in the form of diesel exhaust in the immediate vicinity of the site. However, these emissions are short-term and temporary in nature and will rapidly dissipate and be diluted by the atmosphere downwind of the emission sources. Additionally, odors would be localized and generally confined to the project area. Therefore, odors generated during construction would not adversely affect a substantial number of people to odor emissions, and impacts would be less than significant.

Land uses commonly considered to be potential sources of odorous emissions include wastewater treatment plants, sanitary landfills, food processing facilities, chemical manufacturing plants, rendering plants, paint/coating operations, and concentrated agricultural feeding operations and dairies. The operation of a solar facility is not an odor producer. Therefore, operational impacts related to odor would also be less than significant.

IV. Biological Resources

Environmental Issue Area:	Potentially Significant Impact	Less than Significant with Mitigation Incorporated	Less Than Significant Impact	No Impact
<i>Would the project:</i>				
a) Have a substantial adverse effect, either directly or through habitat modifications, on any species identified as a candidate, sensitive, or special status species in local or regional plans, policies, or regulations, or by the California Department of Fish and Game or U.S. Fish and Wildlife Service?	<input type="checkbox"/>	<input checked="" type="checkbox"/>	<input type="checkbox"/>	<input type="checkbox"/>
b) Have a substantial adverse effect on any riparian habitat or other sensitive natural community identified in local or regional plans, policies, and regulations or by the California Department of Fish and Game or U.S. Fish and Wildlife Service?	<input type="checkbox"/>	<input checked="" type="checkbox"/>	<input type="checkbox"/>	<input type="checkbox"/>
c) Have a substantial adverse effect on state or federally protected wetlands (including, but not limited to, marsh, vernal pool, coastal, etc.) through direct removal, filling, hydrological interruption, or other means?	<input type="checkbox"/>	<input checked="" type="checkbox"/>	<input type="checkbox"/>	<input type="checkbox"/>

d) Interfere substantially with the movement of any native resident or migratory fish or wildlife species or with established native resident or migratory wildlife corridors, or impede the use of wildlife nursery sites?	<input type="checkbox"/>	<input checked="" type="checkbox"/>	<input type="checkbox"/>	<input type="checkbox"/>
e) Conflict with any local policies or ordinances protecting biological resources, such as a tree preservation policy or ordinance?	<input type="checkbox"/>	<input checked="" type="checkbox"/>	<input type="checkbox"/>	<input type="checkbox"/>
f) Conflict with the provisions of an adopted Habitat Conservation Plan, Natural Community Conservation Plan, or other approved local, regional, or state habitat conservation plan?	<input type="checkbox"/>	<input type="checkbox"/>	<input checked="" type="checkbox"/>	<input type="checkbox"/>

Impact Analysis

The following information is summarized from the Biological Technical Report prepared by ECORP Consulting, Inc. and the Aquatic Resource Delineation Report prepared by Hernandez Environmental Services. These reports are provided as Appendix C and D of this Initial Study, respectively.

- a) **Less than Significant with Mitigation Incorporated.** ECORP conducted a literature review, vegetation mapping, and a biological resource assessment of the Survey Area, which includes the project site plus a 500-foot buffer, to document the existing biological conditions and resources, to assess the habitat for its potential to support sensitive plant and wildlife species, as required under CEQA, and to determine whether project-related impacts may occur to sensitive biological resources.

EXISTING CONDITIONS

Literature Review

A literature review was conducted using the California Department of Fish and Wildlife (CDFW) California Natural Diversity Data Base (CNDDB), the California Native Plant Society’s (CNPS’) Electronic Inventory (CNPSEI), and the USFWS Species Occurrence Data to determine the special-status plant and wildlife species that have been documented in the vicinity of the project site.

The literature review resulted in 11 special-status plant and 37 special-status wildlife species that have recently and historically been recorded in the vicinity of the project site or that are highly associated with habitat that occurs within the Survey Area.

Biological Reconnaissance Survey

A biological reconnaissance survey for the Survey Area was conducted on October 25 and 26, 2022. The results of the biological reconnaissance survey, including plants and plant communities, wildlife, special-status species, and special-status habitats (including any potential wildlife corridors) are summarized below.

Vegetation Communities/Land Cover. The majority of the Survey Area consists of creosote bush scrub and disturbed-fourwing saltbush scrub. The location of each vegetation community/land cover in the project site and Survey Area are shown in Figure 5. Acreages of each habitat and vegetation community in the project site are shown in Table 4. A detailed description of each vegetation community/land cover is provided in the *Biological Technical Report for the North Star 1 Project* (Appendix C of this Initial Study).

Table 4. Vegetation Communities and Land Covers in Project Site and in 500-foot Buffer

Vegetation Communities and Land Covers	Acres in Project Site	Acres in 500-foot Buffer
Creosote Bush Scrub (<i>Larrea tridentata</i> Shrubland Alliance)	77.43	101.53
Iodine Bush Scrub (<i>Allenrolfea occidentalis</i> Shrubland Alliance)	21.70	37.12
Disturbed – Iodine Bush Scrub (Disturbed <i>Allenrolfea occidentalis</i> Shrubland Alliance)	40.56	8.35
Blue Palo Verde – Ironwood Woodland (<i>Parkinsonia florida</i> - <i>Olneya tesota</i> Woodland Alliance)	5.44	120.00
Bush Seepweed Scrub (<i>Suaeda moquinii</i> Shrubland Alliance)	5.14	13.24
Disturbed – Bush Seepweed Scrub (Disturbed <i>Suaeda moquinii</i> Shrubland Alliance)	22.80	12.82
Tamarisk Thicket (<i>Tamarix</i> ssp. Semi-natural Shrubland Stands)	-	16.92
Disturbed – Tamarisk Thicket (Disturbed <i>Tamarix</i> ssp. Semi-natural Shrubland Stands)	12.35	-
Arrow Weed Thickets (<i>Pluchea sericea</i> Shrubland Alliance)	-	5.21
Fourwing Saltbrush Scrub (<i>Atriplex canescens</i> Shrubland Alliance)	28.92	21.70
Disturbed Fourwing Saltbrush Scrub (Disturbed <i>Atriplex canescens</i> Shrubland Alliance)	69.44	28.96
Disturbed	1.96	40.17
Active Agriculture	-	-3.43
Aqueduct	-	-5.26
Area Total	285.74	397.33

Source: Appendix C of this Initial Study

Figure 5. Vegetation Communities and Land Cover Types

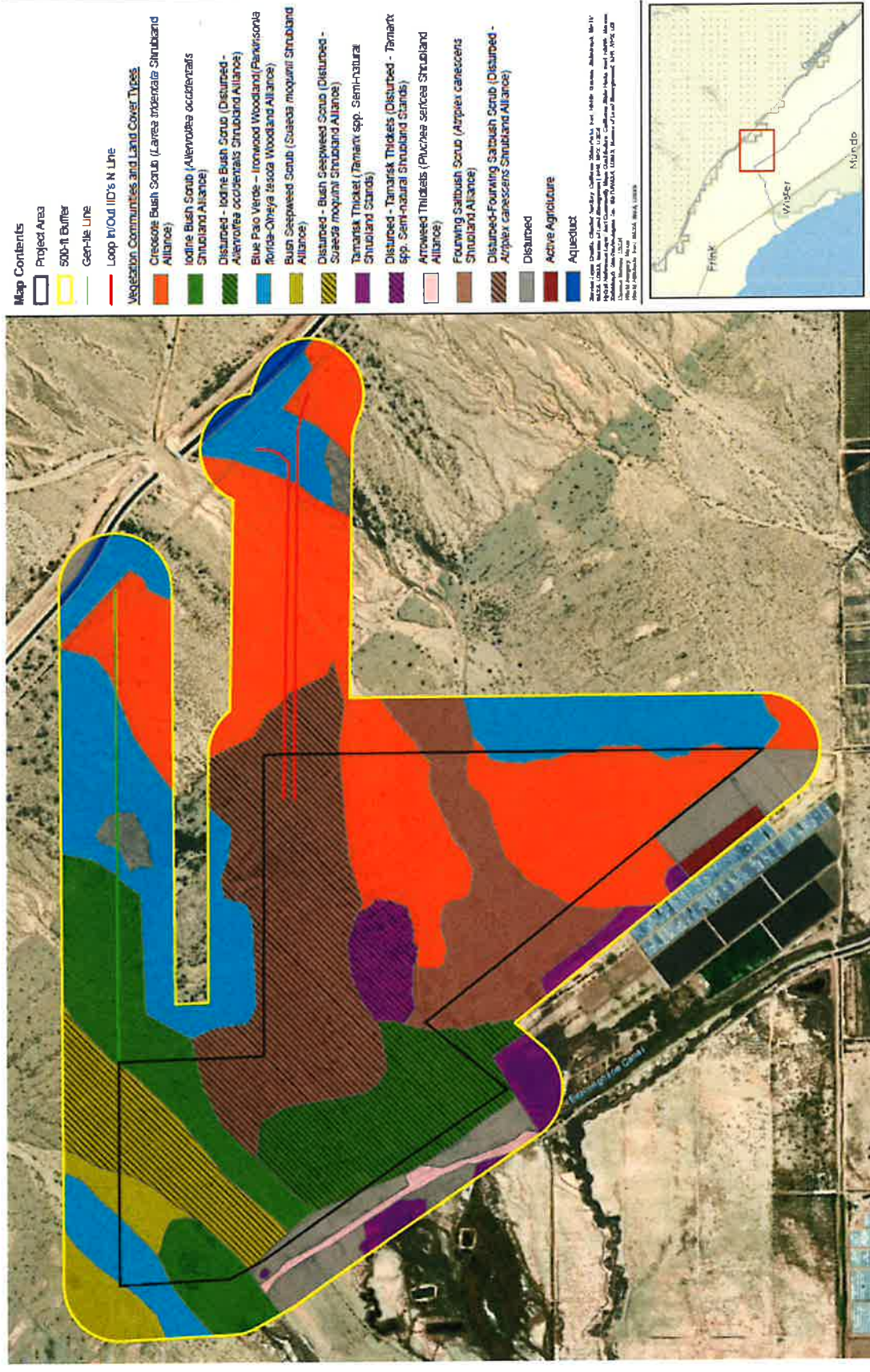

Source: Appendix C of this Initial Study

This page is intentionally blank.

Wildlife Observed. Wildlife observed included zebra-tailed lizard (*Callisaurus draconoides*), side-blotched lizard (*Uta stansburiana*), black-tailed gnatcatcher (*Poliophtila melanura*), American kestrel (*Falco sparverius*) red-tailed hawk (*Buteo jamaicensis*), northern flicker (*Colaptes auratus*), Abert's towhee (*Melozone aberti*), killdeer (*Charadrius vociferus*), rock wren (*Salpinctes obsoletus*), verdin (*Auriparus flaviceps*), great-tailed grackle (*Quiscalus mexicanus*), Say's phoebe (*Sayornis saya*), white-crowned sparrow (*Zonotrichia leucophrys*), great blue heron (*Ardea herodias*), common raven (*Corvus corax*), desert cottontail (*Sylvilagus audubonii*), antelope ground squirrel (*Ammospermophilus leucurus*), and bat sign (Order Chiroptera)(guano). A full list of wildlife species observed on or immediately adjacent to the Survey Area is included in Appendix C of this Initial Study.

Special-Status Species Assessment. As previously mentioned above, the literature review resulted in 11 special-status plant and 37 special-status wildlife species that have recently and historically been recorded in the vicinity of the project site or that are highly associated with habitat that occurs within the Survey Area.

PLANTS

Numerous special-status plant species have been recorded within five miles of the project site, according to the CNDDDB and CNPSEI. Of all available records, a total of eight species were identified as those with the potential for occurrence within the vicinity of the project site. Descriptions of the CNPS designations are shown in Table 5.

Table 5. CNPS Status Designations

List Designation	Meaning
1A	Plants Presumed Extirpated in California and Either Rare or Extinct Elsewhere
1B	Plants Rare, Threatened, or Endangered in California and Elsewhere
2A	Plants Presumed Extirpated in California, But Common Elsewhere
2B	Plants Rare, Threatened, or Endangered in California, But More Common Elsewhere
3	Plants about which we need more information; a review list
4	Plants of limited distribution; a watch list
List 1B, 2, and 4 extension meanings:	
.1	Seriously threatened in California (over 80 percent of occurrences threatened/high degree and immediacy of threat)
.2	Moderately threatened in California (20 to 80 percent occurrences threatened/moderate degree and immediacy of threat)
.3	Not very threatened in California (less than 20 percent of occurrences threatened/low degree and immediacy of threat or no current threats known)

Source: Appendix C of this Initial Study

Due to the presence of suitable habitat and several known recent occurrences within five miles of the project site, the following species were determined to have a **high** potential to occur:

- Harwood's milk-vetch (*Astragalus insularis* var. *harwoodii*) is a CRPR 2B.2 plant species. Harwood's milk-vetch is known to occur in Mojavean desert scrub and desert dunes within sometimes gravelly or sandy soils. One recent (2005) CNDDDB record was located less than one mile east of the project site near the Gas Line Road. There is potential habitat within the project site for this species in the creosote bush scrub habitats.
- Munz's cholla (*Cylindropuntia munzii*) is a CRPR 1B.3 plant species. Munz's cholla is known to occur in Sonoran Desert scrub within gravelly or sandy soils. There are CNDDDB record observations approximately five miles east of the project site in large

portions of the Chocolate Mountain Aerial Gunnery Range. There is potential habitat within the project site for this species in the creosote bush scrub habitats.

Due to the presence of suitable habitat and several known recent occurrences within five miles of the project site, the following species was determined to have a **moderate** potential to occur:

- Orocopia sage (*Salvia greatae*) is a CRPR 1B.3 plant species. Orocopia sage is known to occur in Mojavean and Sonoran Desert scrub habitat. One historic (1990) CNDDDB record was located approximately five miles northwest of the project site near Siphon Seventeen. There is potential habitat within the project site for this species in the creosote bush scrub habitats.

The following species were found to have a **low** potential to occur within the project site because of limited habitat for the species on the site and a known occurrence has been reported in the database, but not within five miles of the project site, or suitable habitat strongly associated with the species occurs within the project site, but no records were found in the database search:

- Gravel milk-vetch (*Astragalus sabulonum*), CRPR 2B.2
- Sand evening-primrose (*Chylismia arenaria*), CRPR 2B.2
- Las Animas colubrina (*Colubrina californica*), CRPR 2B.3
- Glandular ditaxis (*Ditaxis claryana*), state-listed endangered, CRPR 1B.2
- Narrow-leaf sandpaper-plant (*Petalonyx linearis*), CRPR 2B.3

WILDLIFE

The literature search documented 37 special-status wildlife species in the vicinity of the project site or with habitat within the Survey Area, 10 of which are federally and/or state-listed. Of the 37 special-status wildlife species identified in the literature review, two were present within the project site, four were found to have a high potential to occur, six were found to have a moderate potential to occur and 10 were found to have a low potential to occur; the remaining 15 species are presumed absent from the project site. A discussion of the special-status wildlife species found onsite and species that have a high or moderate potential to occur within the Survey Area are provided below.

The following species were **observed** on the site during the reconnaissance survey. Special-status species wildlife species observed during the reconnaissance survey are shown in Figure 6.

- Loggerhead shrike (*Lanius ludovicianus*) is a CDFW species of special concern (SSC). This species prefers open country with scattered shrubs and trees. They frequent agricultural fields, abandoned orchards, desert scrublands, and riparian areas. One individual was observed perching in the creosote bush scrub in the southwestern section of the Survey Area during the biological reconnaissance survey.
- Long-eared owl (*Asio otus*) is a CDFW SSC. This species prefers areas with dense trees for nesting and/or roosting adjacent to open areas for hunting. Long-eared owls are found in a variety of woodland habitats including forests adjacent to meadows and streamside desert groves. A pair of long-eared owls were observed in the Survey Area along the northern gen-tie in the blue palo verde - ironwood woodland community during the biological reconnaissance survey.

Figure 6. Special-Status Wildlife Species Observed within Survey Area

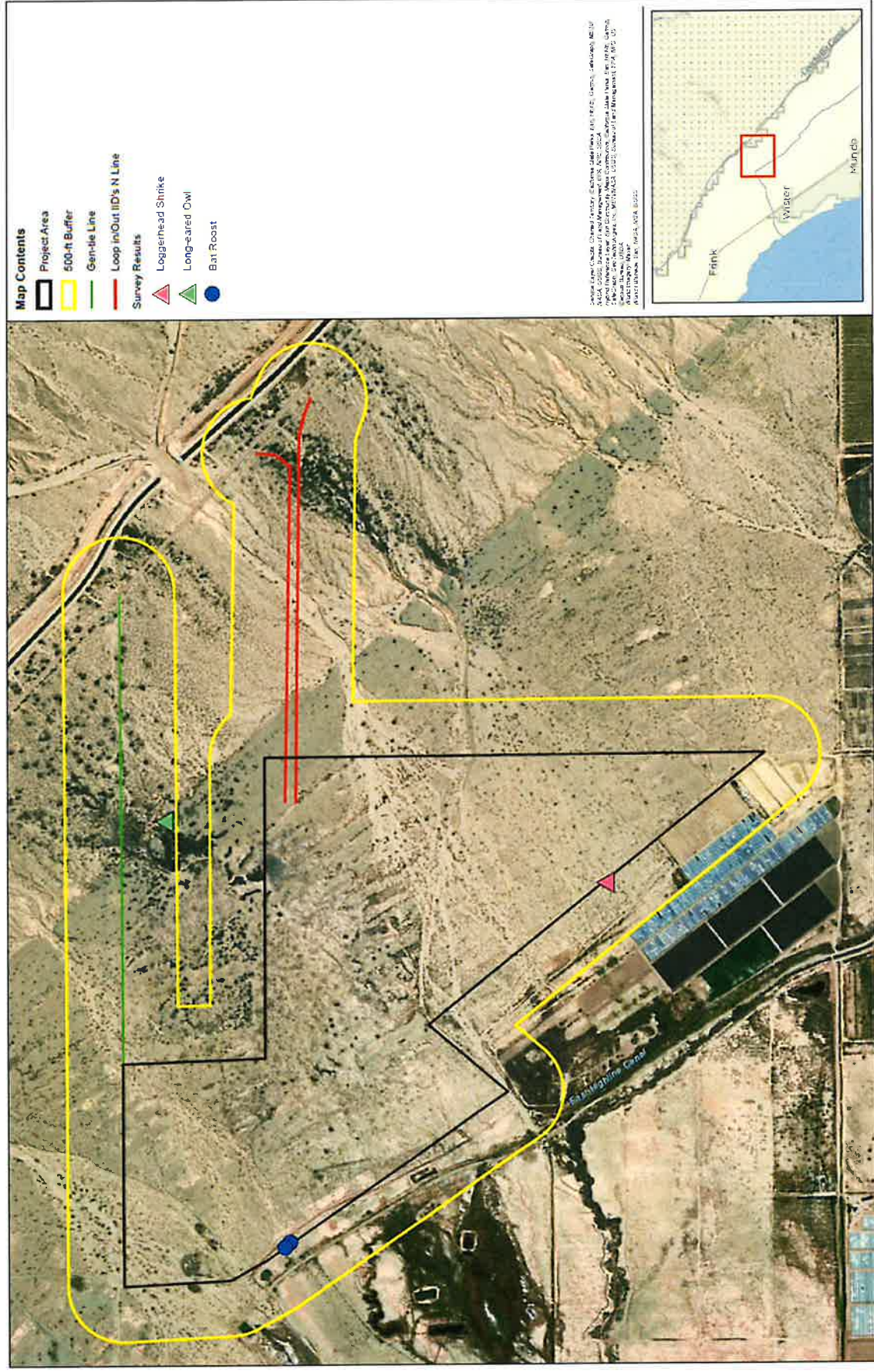

Source: Appendix C of this Initial Study



This page is intentionally blank.

Four species were found to have **high** potential to occur within the Survey Area due to the presence of highly suitable habitat for the species on the site and/or because a known occurrence has been recorded within five miles of the site:

- Burrowing owl (*Athene cunicularia*) is a CDFW SSC, BLM Sensitive species, and Imperial County species of conservation focus. It is typically found in dry open areas with few trees and short grasses; it is also found in vacant lots near human habitation. It uses uninhabited mammal burrows for roosts and nests, often in close proximity to California ground squirrel colonies. Highly suitable habitat for burrowing owl is present throughout most of the Survey Area. Additionally, numerous occurrences of burrowing owls within five miles of the Survey Area have been documented in the CNDDDB.
- Pallid bat (*Antrozous pallidus*) is a CDFW SSC and BLM Sensitive species. This species is commonly found in desert habitats and is known to roost in anthropogenic structures such as buildings. Roosting habitat for this species is present within the abandoned building located in the northwest corner of the project site. Bat sign (guano and urine staining) was observed inside the building as well as evidence of previous roosting by pallid bat (large, culled insect parts and moth wings among the other bat sign present).
- Yuma myotis (*Myotis yumanensis*) is a BLM Sensitive species. This species is found in desert scrub and woodland habitats near water and commonly forms maternity roosts in anthropogenic structures such as buildings. Roosting habitat for this species is present within the abandoned building located in the northwest corner of the project site. Bat sign (guano and staining) was observed inside the building.
- Desert kit fox (*Vulpes macrotis arsipus*) is a fur-bearing mammal that is protected under the California Code of Regulations Title 14, Chapter 5, Section 460 which prohibits take of the species at any time. Therefore, CDFW does not have a mechanism for take of the species by development projects. The desert kit fox is found in desert habitats that include vegetation communities in the Survey Area such as creosote bush scrub. Suitable habitat for desert kit fox is present throughout most of the Survey Area and burrows that may have been dug by desert kit fox were observed during the reconnaissance survey.

Six species were found to have **moderate** potential to occur within the project site because habitat for the species occurs on the site and a known occurrence exists within the database search, but not within five miles of the site; or a known occurrence exists within five miles of the site and marginal or limited amounts of habitat occurs within the project site:

- Couch's spadefoot (*Scaphiopus couchii*) is a CDFW SSC. This species is found underground in arid and desert regions of creosote bush scrub and sandy washes and surfaces during rain events. There is suitable habitat for this species within the creosote bush scrub and other desert scrub habitats onsite.
- Flat-tailed horned lizard (*Phrynosoma mcallii*) is a CDFW SSC, BLM Sensitive species, and Imperial County Species of conservation focus. This species is most commonly found on sandy flats and valleys within desert scrub habitats with little or no windblown sand. They can also be found on salt flats and gravelly soils. The creosote bush scrub and sandy wash habitats in the project site provides suitable habitat for the flat-tailed horned lizard.
- Townsend's big-eared bat (*Corynorhinus townsendii*) is a CDFW SSC. The project site is within the known range of this species and this species is known to roost in buildings. Potential roosting habitat for this species is present within the abandoned building present in the northwest corner of the project site.
- Small-footed myotis (*Myotis ciliolabrum*) is a BLM Sensitive species. The project site is within the known range of this species and this species is known to sometimes roost

in buildings. Potential roosting habitat for this species is present within the abandoned building present in the northwest corner of the project site.

- Fringed myotis (*Myotis thysanodes*) is a BLM Sensitive species. The project site is within the known range of this species and this species is known to sometimes roost in buildings. Potential roosting habitat for this species is present within the abandoned building present in the northwest corner of the project site.
- American badger (*Taxidea taxus*) is a CDFW SSC. American badgers are found in a wide variety of open habitats with friable soils including desert scrub and woodland habitats. Suitable habitat for this species is present throughout the Survey Area.

Ten species were found to have a **low** potential to occur within the project site because limited habitat for the species occurs on the site and a known occurrence has been reported in the database, but not within five miles of the site, or suitable habitat strongly associated with the species occurs on the site, but no records were found in the database search:

- desert tortoise (*Gopherus agassizii*), federally listed threatened, and state listed threatened,
- southwestern willow flycatcher (*Empidonax traillii* ssp. *extimus*), federally listed endangered and state-listed endangered
- Yellow-breasted chat (*Icteria virens*), CDFW SSC,
- California black rail (*Laterallus jamaicensis coturniculus*), state-listed threatened, CDFW Fully Protected, BLM Sensitive
- Gila woodpecker (*Melanerpes uropygialis*), state-listed endangered, BLM Sensitive
- Yuma Ridgway's rail (*Rallus obsoletus* ssp. *yumanensis*), federally-listed endangered, state listed threatened, CDFW Fully Protected
- yellow warbler (*Setophaga petechia*), CDFW SSC
- Crissal thrasher (*Toxostoma crissale*), CDFW SSC, BLM Sensitive
- Long-eared myotis (*Myotis evotis*), BLM Sensitive
- Yuma hispid cotton rat (*Sigmodon hispidus eremicus*) CDFW SSC.

USFWS Designated Critical Habitat

The Survey Area is not located within any USFWS-designated critical habitat. The nearest critical habitat is for the desert tortoise located approximately eight miles northeast of the project site.

PROJECT IMPACTS

Special-Status Plants

The literature review identified eight special-status plant species that have the potential to occur within the project site. However, five of these plant species have a low potential to occur due to distance from the project site being greater than five miles. These species include gravel milk-vetch, sand evening-primrose, Las Animas colubrina, glandular ditaxis, and narrow-leaf sandpaper-plant. There is moderate potential for one rare plant species, Orocopia sage (CRPR 1B.3), and high potential for two rare plant species, Harwood's milk-vetch (CRPR 2B.2) and Munz's cholla (1B.3), to be present within the project site. Suitable habitat for these species is present within the creosote bush scrub habitats. Impacts that may occur to the species include loss of individuals, habitat, and seedbank. Depending on the size of the population, this impact may be significant. Implementation of Mitigation Measures BIO-1 through BIO-3 would reduce potential impacts on special-status plant species to a level less than significant.

Special-Status Wildlife

The literature review identified 37 special-status wildlife species that have the potential to occur within the Survey Area. However, 25 of these species have a low or no potential to occur due to the lack of suitable habitat, limited habitat within the Survey Area, and/or the project site occurs outside the known range of these species.

Two special-status wildlife species (CDFW SSC species) were observed on site during the habitat assessment: loggerhead shrike and long-eared owl. An additional four species were determined to have a high potential to occur: burrowing owl, pallid bat, Yuma myotis, and desert kit fox and six species were determined to have a moderate potential to occur: Couch's spadefoot, flat-tailed horned lizard, Townsend's big-eared bat, small-footed myotis, fringed myotis, and American badger. Direct impacts to these species that could occur include injury, mortality, nest or maternity colony failures, and loss of young. Indirect impacts include loss of nesting, roosting, and foraging habitat, and increase in anthropogenic effects (i.e., noise levels, introduction of invasive/nonnative species, increase in human activity, increase in dust). Impacts to these species could be considered significant. Implementation of Mitigation Measures BIO-2 through BIO-6 would reduce potential impacts on special-status wildlife species to a level less than significant.

There is foraging habitat for a number of raptor species and breeding habitat for numerous passerine species that are protected by the MBTA throughout the project site. The site provides nesting habitat for ground-nesting species as well as species that nest in desert scrub and woodland habitats. Direct impacts to nesting avian species include injury, mortality, loss of young, and nest failure. Indirect impacts include loss of foraging and nesting habitat for passerine and raptors species, increase in noise and human activities, and potential introduction of invasive/nonnative species. Impacts to nesting avian species could be considered significant. Implementation of Mitigation Measures BIO-2, BIO-3, BIO-5 and BIO-6 would reduce potential impacts on nesting avian species to a level less than significant.

A previously occupied bat roost site was documented in an abandoned building and adjacent outhouse structure in the northwest corner of the project site. The evidence of bat use indicated that this building may be a site used by bat maternity colonies. Further, this building provides suitable habitat for CDFW SSC bat species and BLM Sensitive bat species. Bat species in California are protected by Section 4150 (protection of non-game mammals from take) of the California Fish and Game Code. Section 4150 of the California Fish and Game Code prohibits the take of any naturally occurring mammals in California that are nongame mammals, which includes all species of the Order Chiroptera (bats). Further, bat maternity roosting habitats are protected as native wildlife nursery sites under CEQA. The reconnaissance survey was conducted outside of the maternity season, but based on the quantity of bat sign observed, there is high likelihood that this structure serves as a maternity roost location. Direct impacts to special-status bat species and/or bat maternity colonies that could occur include injury, mortality, maternity colony failures, and loss of young. Indirect impacts include loss of roosting habitat, and increase in anthropogenic effects (i.e., noise levels, increase in human activity, increase in dust). Impacts to these species and maternity roosting sites could be considered significant. Implementation of Mitigation Measures BIO-2, BIO-3, BIO-7 and BIO-8 would reduce potential impacts on bat species to a level less than significant.

Mitigation Measures:

The following actions are recommended to be completed prior to project implementation:

- BIO-1 Rare Plant Surveys:** Prior to initiating ground disturbance, rare plant surveys shall be conducted within suitable habitat within the Survey Area during the appropriate blooming period for the Orocopia sage (approximately March through April), Harwood's milk-vetch (approximately January through May), and Munz's cholla (approximately May). The surveys shall be conducted by a

botanist or qualified biologist in accordance with the USFWS Guidelines for Conducting and Reporting Botanical Inventories for Federally Listed, Proposed, and Candidate Plants (USFWS 1996); the CDFW Protocols for Surveying and Evaluating Impacts to Special Status Native Plant Populations and Sensitive Natural Communities (CDFW 2018); and the CNPS Botanical Survey Guidelines (CNPS 2001). If any special-status species are observed during the rare plant surveys, the location of the individual plant or population will be recorded with a submeter GPS device for mapping purposes. Consultation with CDFW may be required to develop a mitigation plan or additional avoidance and minimization measures if project-related impacts to rare plants within the project site are unavoidable. Mitigation measures that may be implemented if the species is observed include establishing a no-disturbance buffer around locations of individuals or a population, salvage or seed collection, and additional monitoring requirements.

BIO-2

General Impact Avoidance and Minimization Measures. The following measures will be applicable throughout the life of the project:

- To reduce the potential indirect impact on migratory birds, bats and raptors, the project shall comply with the APLIC 2012 Guidelines for overhead utilities, as appropriate, to minimize avian collisions with transmission facilities (APLIC 2012)
- All electrical components on the project site shall be either underground or protected so that there will be no exposure to wildlife and therefore no potential for electrocution.
- The project proponent shall designate a Project Biologist who shall be responsible for overseeing compliance with protective measures for biological resources during vegetation clearing and work activities within and adjacent to areas of native habitat. The Project Biologist shall be familiar with the local habitats, plants, and wildlife. The Project Biologist shall also maintain communications with the Contractor to ensure that issues relating to biological resources are appropriately and lawfully managed and shall monitor construction. The Project Biologist shall monitor activities within construction areas during nesting bird season (generally February 1 to September 15), such as vegetation removal, the implementation of Best Management Practices (BMPs), and installation of security fencing to protect native species. The Project Biologist shall ensure that all wildlife and regulatory agency permit requirements, conservation measures, and general avoidance and minimization measures are properly implemented and followed.
- The boundaries of all areas to be newly disturbed (including solar facility areas, staging areas, access roads, and sites for temporary placement of construction materials and spoils) shall be delineated with stakes and flagging prior to disturbance. All disturbances, vehicles, and equipment shall be confined to the flagged areas.
- No potential wildlife entrapments (e.g., trenches, bores) shall be left uncovered overnight. Any uncovered pitfalls will be excavated to 3:1 slopes at the ends to provide wildlife escape ramps. Alternatively,

man-made ramps may be installed. Covered pitfalls will be covered completely to prevent access by small mammals or reptiles.

- To avoid wildlife entrapment (including birds), all pipes or other construction materials or supplies shall be covered or capped in storage or laydown areas, and at the end of each workday in construction, quarrying and processing/handling areas. No pipes or tubing of sizes or inside diameters ranging from 1 to 10 inches shall be left open either temporarily or permanently.
- No anticoagulant rodenticides, such as Warfarin and related compounds (indandiones and hydroxycoumarins), shall be used within the project site, on off-site project facilities and activities, or in support of any other project activities.
- All trash and food-related waste shall be placed in self-closing containers and removed regularly from the site to prevent overflow. Workers shall not feed wildlife. Water applied to dirt roads and construction areas for dust abatement shall be used the minimal amount needed to meet safety and air quality standards to prevent the formation of puddles, which could attract wildlife. Pooled rainwater or floodwater within retention basins shall be removed to avoid attracting wildlife to the active work areas.
- To minimize the likelihood for vehicle strikes on wildlife, speed limits shall not exceed 15 miles per hour when driving on access roads. All vehicles required for O&M must remain on designated access/maintenance roads.
- Avoid nighttime construction lighting or if nighttime construction cannot be avoided, use shielded directional lighting pointed downward and towards the interior of the project sites, thereby avoiding illumination of adjacent natural areas and the night sky.
- All construction equipment used for the projects shall be equipped with properly operating and maintained mufflers.
- Hazardous materials and equipment stored overnight, including small amounts of fuel to refuel hand-held equipment, shall be stored within secondary containment when within 50 feet of open water to the fullest extent practicable. Secondary containment shall consist of a ring of sandbags around each piece of stored equipment/structure. A plastic tarp/visqueen lining with no seams shall be placed under the equipment and over the edges of the sandbags, or a plastic hazardous materials secondary containment unit shall be utilized by the Contractor.
- The Contractor will be required to conduct vehicle refueling in upland areas where fuel cannot enter waters of the U.S. and in areas that do not have potential to support federally threatened or endangered species. Any fuel containers, repair materials,

including creosote-treated wood, and/or stockpiled material that is left on site overnight, shall be secured in secondary containment within the work area and staging/assembly area and covered with plastic at the end of each workday.

- In the event that no activity is to occur in the work area for the weekend and/or a period of time greater than 48 hours, the Contractor shall ensure that all portable fuel containers are removed from the project site.
- All equipment shall be maintained in accordance with manufacturer's recommendations and requirements.
- Equipment and containers shall be inspected daily for leaks. Should a leak occur, contaminated soils and surfaces will be cleaned up and disposed of following the guidelines identified in the Stormwater Pollution Prevention Plan or equivalent, Materials Safety Data Sheets, and any specifications required by other permits issued for the project.
- The Contractor shall utilize off-site maintenance and repair shops as much as possible for maintenance and repair of equipment.
- If maintenance of equipment must occur onsite, fuel/oil pans, absorbent pads, or appropriate containment will be used to capture spills/leaks within all areas. Where feasible, maintenance of equipment shall occur in upland areas where fuel cannot enter waters of the U.S. and in areas that do not have potential to support federally threatened or endangered species.
- Appropriate BMPs shall be used by the Contractor to control erosion and sedimentation and to capture debris and contaminants from construction to prevent their deposition in waterways.
- Erosion and sediment control devices used for the proposed project, including fiber rolls and bonded fiber matrix, shall be made from biodegradable materials such as jute, with no plastic mesh, to avoid creating a wildlife entanglement hazard.
- Firearms, open fires, and pets shall be prohibited at all work locations and access roads. Smoking shall be prohibited along the project alignment.
- Cross-country vehicle and equipment use outside of approved designated work areas and access roads shall be prohibited to prevent unnecessary ground and vegetation disturbance.
- Any injured or dead wildlife encountered during project-related activities shall be reported to the project biologist, biological monitor, CDFW, or a CDFW-approved veterinary facility as soon as possible to report the observation and determine the best course of action. For special-status species, the Project Biologist shall notify the County,

USFWS, and/or CDFW, as appropriate, within 24 hours of the discovery.

- Stockpiling of material shall only be allowed within established work areas.
- The Contractor shall actively manage the spread of noxious weeds by implementing weed control activities, including, but not limited to, cleaning equipment and inspecting equipment prior to transport to the sites and cleaning of tires and equipment prior to leaving the site. The introduction of exotic, nonnative, weed, and/or invasive plant species will be avoided and controlled wherever possible, and may be achieved through physical or chemical removal and prevention, limiting the size of any vegetation and/or ground disturbance to the absolute minimum, and limiting ingress and egress to defined routes. Preventing exotic plants from entering the site via vehicular sources will include measures such as cleaning vehicles coming into and going from the site.
- The ground beneath all parked equipment and vehicles shall be inspected for wildlife before moving.

BIO-3

Worker Environmental Awareness Program. Prior to project construction, a Worker Environmental Awareness Program shall be developed and implemented by a qualified biologist and shall be available in both English and Spanish. Handouts summarizing potential impacts on special-status biological resources and the potential penalties for impacts on these resources shall be provided to all construction personnel. At a minimum, the education program shall include the following:

- the purpose for resource protection;
- a description of special-status species including representative photographs and general ecology;
- occurrences of USACE, RWQCB, and CDFW regulated features in the project study area;
- regulatory framework for biological resource protection and consequences if violated;
- sensitivity of the species to human activities;
- avoidance and minimization measures designed to reduce the impacts on special-status biological resources;
- environmentally responsible construction practices;
- reporting requirements;
- the protocol to resolve conflicts that may arise at any time during the construction process; and

- workers sign an acknowledgement form indicating that the Environmental Awareness Training and Education Program that has been completed, shall be kept on record.

BIO-4

Burrowing Owl Avoidance and Minimization: Take avoidance (pre-construction) surveys for burrowing owl shall be completed prior to project construction. Surveys shall be conducted as detailed within Appendix D of the Staff Report on Burrowing Owl Mitigation (California Department of Fish and Game [CDFG] 2012). If burrowing owl is not detected, construction may proceed.

- If burrowing owl is identified during the non-breeding season (September 1 through January 31), then a 50-meter buffer will be established by the biological monitor. Construction within the buffer will be avoided until a qualified biologist determines that burrowing owl is no longer present or until a CDFW-approved exclusion plan has been implemented. The buffer distance may be reduced if noise attenuation buffers such as hay bales are placed between the occupied burrow and construction activities.
- If burrowing owl is identified during the breeding season (February 1 through August 31), then an appropriate buffer will be established by the biological monitor in accordance with the Staff Report on Burrowing Owl Mitigation (CDFG 2012). Construction within the buffer will be avoided until a qualified biologist determines that burrowing owl is no longer present or until young have fledged. The buffer distance may be reduced in consultation with CDFW if noise attenuation buffers such as hay bales are placed between the occupied burrow and construction activities.

BIO-5

Pre-Construction Nesting Bird Survey: If construction or other project activities are scheduled to occur during the bird breeding season (typically February 1 through August 31 for raptors and February 15 through August 31 for the majority of migratory bird species), a pre-construction nesting-bird survey shall be conducted by a qualified avian biologist to ensure that active bird nests, including those for loggerhead shrike and burrowing owl, will not be disturbed or destroyed. The survey shall be completed no more than three days prior to initial ground disturbance. The nesting-bird survey should include the project site and adjacent areas where project activities have the potential to affect active nests, either directly or indirectly due to construction activity or noise. If an active nest is identified, the biologist shall establish an appropriately sized disturbance-limit buffer around the nest using flagging or staking. Construction activities shall not occur within any disturbance-limit buffer zones until the nest is deemed inactive by the qualified biologist. If construction activities cease for a period of greater than three days during the bird breeding season, a pre-construction nesting bird survey shall be conducted prior to the commencement of activities. Final construction buffers or setback distances shall be determined by the qualified biologist in coordination with USFWS and CDFW on a case-by-case basis, depending on the species, season in which disturbance shall occur, the type of disturbance, and other factors that could influence susceptibility to disturbance (e.g., topography, vegetation, existing disturbance levels, etc.).

BIO-6

Pre-Construction Survey for Special-Status Species: A pre-construction survey shall be conducted for special-status wildlife species within all areas of

potential permanent and temporary disturbance. The pre-construction survey shall take place no more than 14 days prior to the start of ground-disturbing activities. The pre-construction surveys shall take place regardless of breeding season timing and shall focus on identifying the presence of special-status wildlife species present within the Survey Area or that were identified as having a high/moderate potential to occur on the site. These species include, but are not limited to, flat-tailed horned lizard, burrowing owl, monarch butterfly, desert kit fox, loggerhead shrike, western yellow bat, Yuma myotis, American badger. Should any special status species be identified during the pre-construction survey, consultation to develop suitable avoidance and minimization measures with the appropriate agency (USFWS, CDFW) may need to be undertaken.

BIO-7 Compliance with Section 4150 of California Fish and Game Code: A qualified bat biologist shall conduct an appropriate combination of sampling, exit counts, and acoustic surveys to determine if bats are using the abandoned building and adjacent outhouse structure in the northwest corner of the project site. If project-related impacts to bat species are unavoidable, additional measures may need to be implemented to reduce or eliminate impacts to bat species, including maternity roosts.

BIO-8 Preparation of a Bat Management Plan: No more less than one year prior to initial site clearing activities, focused surveys for bat species shall be completed by a qualified bat biologist to determine the approximate size of the colony(s), species present, and features being used within the abandoned building and adjacent outhouse structure in the northwest corner of the project site. Focused surveys shall include a combination of nighttime emergence counts and acoustic techniques appropriate for the roosting habitat and time of year. At a minimum, focused surveys shall be conducted during the spring, summer, fall, and winter to determine how the habitat is being used by bats throughout the year with at least two surveys conducted during the maternity season to determine a pre- and post-volant count of colonies present. If roosting bats are found during the surveys, a Bat Management Plan identifying situation-specific and species-specific avoidance and minimization measures to reduce impacts to roosting bats shall be prepared prior to the commencement of initial site clearing activities. The Bat Management Plan shall include, as appropriate to the findings of the focused surveys and roosting habitat affected, spatial and temporal avoidance measures, no-disturbance buffers, passive exclusion of bats outside of the maternity season (if necessary), and identification of species-specific replacement or alternative habitat to mitigate for permanent maternity roosting habitat loss.

- b) **Less than Significant with Mitigation Incorporated.** The location of each vegetation community/land cover in the project site and Survey Area are shown in Figure 5. Acreages of each habitat and vegetation community in the project site are shown in Table 4. Blue palo verde/ironwood woodland, bush seepweed scrub, and iodine bush scrub are considered CDFW sensitive plant communities. Construction activities such as site preparation and grading may result in the removal of vegetation and would be considered a significant impact. Implementation of Mitigation Measure BIO-9 would reduce the potential impact to a level less than significant.

Mitigation Measure:

BIO-9 Compensatory Mitigation: To the greatest extent possible, plans shall avoid impacts to blue palo verde/ironwood woodland, bush seepweed scrub, and iodine bush scrub. If blue palo verde/ironwood woodland, bush seepweed scrub, and iodine bush scrub cannot be avoided, the project applicant will provide compensatory mitigation for direct impacts consisting of habitat establishment or

enhancement through an agency-approved in-lieu fee program or conservation bank at a minimum of a 3:1 ratio.

- c) **Less than Significant Impact with Mitigation Incorporated.** According to the *Aquatic Resource Delineation Report* (Appendix D of this Initial Study), the project area is located within the Colorado River Basin Plan and the Imperial Valley hydrologic unit. The project site contains ephemeral streams that flow from east to west and are unnamed tributaries that form a braided channel to the Salton Sea. The study area does not contain federally defined wetlands. However, within the study area, there is a total of 66.27 acres of ephemeral streams that fall under CDFW jurisdiction, 59.06 acres of ephemeral streams that are classified as waters of the United States, and 59.34 acres of ephemeral streams that are considered waters of the State – all of which have the potential to be impacted by the proposed project.

Impacts to aquatic features may require permits from several regulatory agencies pursuant to federal and State laws. Jurisdictional waters would require certification compliance with Section 401 of the Clean Water Act (CWA) (USACE) and the Porter-Cologne Act (RWQCB), and an agreement pursuant to California Fish and Game Code Sections 1600 and 1602 (CDFW). With implementation of Mitigation Measure BIO-10, impacts to jurisdictional waters would be reduced to a level less than significant with compliance to aquatic resources regulatory permitting.

Mitigation Measure:

BIO-10 Aquatic Resources Regulatory Permitting. If project-related impacts occur to the riparian areas that may also fall under the jurisdiction of the USACE, CDFW, and/or RWQCB, a regulatory permit with those agencies is needed prior to the impact occurring. Refer to the *Aquatic Resource Delineation Report* (2022) for preliminary determination of regulatory limits areas that may be regulated by USACE, CDFW, or RWQCB. Permitting includes preparation and submittal of a Pre-Construction Notification under Section 404 of the federal CWA, an Application for Water Quality Certification under Section 401 of the federal CWA and a Notification of Lake or Streambed Alteration under Section 1600 of the California Fish and Game Code. A completed CEQA document, and Notice of Determination, will be necessary to submit along with the applications. Other items such as finalized project plans, quantities of fill material, supporting technical studies, etc., are also submitted along with the applications. As a part of this process, the project must also identify and approve mitigation through the respective agencies. Mitigation can include onsite or offsite options or could include payment of an in-lieu fee to a conservation organization. Types of mitigation can include restoration, creation, rehabilitation, enhancement, or other types of habitat improvement. Typically, the type of mitigation and acreage of mitigation is negotiated with the regulatory agencies during the permitting process.

- d) **Less than Significant with Mitigation Incorporated.** The project site is located in generally undeveloped open space but is adjacent to areas containing existing disturbances (i.e., roads and active agricultural land). The project site is not in a recognized species corridor or habitat linkage, but the majority of the site contains suitable vegetation and/or cover to support some wildlife movement. Due to the close distance to the Coachella Canal, wildlife movement opportunities connecting the project site to large, undeveloped natural areas is limited. However, the desert scrub and woodland habitats could act as a potential corridor and nursery site for migrating wildlife species. Additionally, the abandoned building present in the northwest corner of the project site may serve as a native wildlife nursery site for roosting bats. However, implementation of Mitigation Measures BIO-2, BIO-3, BIO-7 and BIO-8 would reduce potential impacts to a level less than significant.
- e) **Less than Significant with Mitigation Incorporated.** As described in Responses IV. a-c), the proposed project has the potential to impact special-status plant and wildlife species,

sensitive vegetation communities, and wetlands during construction. However, the proposed project would not conflict with any local policies or ordinances protecting biological resources with implementation of Mitigation Measures BIO-1 through BIO-10 to reduce potential impacts to special status plants, wildlife, sensitive communities, and aquatic resources to a less than significant level.

- f) **Less than Significant Impact.** The Desert Renewable Energy Conservation Plan (DRECP) is designed to provide effective protection and conservation of desert ecosystems while allowing for the appropriate development of renewable energy projects. Within the DRECP, the BLM designates Areas of Critical Environmental Concern (ACEC), where special management attention is needed to protect important historical, cultural, and scenic values, or fish and wildlife or other natural resources. The project is located within the DRECP Area but does not fall into a designated ACEC. The proposed project would adhere to applicable policies and guidelines in Imperial County’s Conservation and Open Space Element and meet the requirements outlined in the plan. This is considered a less than significant impact.

V. Cultural Resources

Environmental Issue Area:	Potentially Significant Impact	Less than Significant with Mitigation Incorporated	Less Than Significant Impact	No Impact
Would the project:				
a) Cause a substantial adverse change in the significance of a historical resource pursuant to §15064.5?	<input type="checkbox"/>	<input checked="" type="checkbox"/>	<input type="checkbox"/>	<input type="checkbox"/>
b) Cause a substantial adverse change in the significance of an archaeological resource pursuant to §15064.5?	<input type="checkbox"/>	<input checked="" type="checkbox"/>	<input type="checkbox"/>	<input type="checkbox"/>
c) Disturb any human remains, including those interred outside of dedicated cemeteries?	<input type="checkbox"/>	<input checked="" type="checkbox"/>	<input type="checkbox"/>	<input type="checkbox"/>

Impact Analysis

The following information is summarized from the *Cultural Resources Inventory Report for the North Star 1 Project* and *Archaeological and Architectural History Resources Evaluations for the North Star 1 Project* prepared by ECORP. These reports are provided as Appendix E1 and Appendix E2 of this Initial Study, respectively.

- a) **Less than Significant Impact with Mitigation Incorporated.** ECORP Consulting, Inc. prepared a *Cultural Resources Inventory Report* (Appendix E1 of this Initial Study) for the proposed project, which included a records search, Sacred Lands Files search, and a pedestrian survey. Following the pedestrian survey, ECORP prepared the *Archaeological and Architectural History Resources Evaluations for the North Star 1 Project* (Appendix E2 of this Initial Study), which evaluates resources within the project area for listing on the National Register of Historic Places (NRHP) and California Register of Historical Resources (CRHR). The results are summarized below.

Sacred Lands File Search

On June 7, 2022, a letter was sent to the Native American Heritage Commission (NAHC) requesting a search of their Sacred Lands File (SLF) to identify spiritually significant and/or

sacred sites or traditional use areas in the project vicinity. The NAHC was also asked to provide a list of local Native American tribes, bands, or individuals that may have concerns or interests regarding cultural resources potentially occurring within the project area. The NAHC SLF search results response was received on July 7, 2022, with positive results.

Records Search

The records search consisted of a review of previous research and literature, records on file with the South Coastal Information Center (SCIC) for previously recorded resources, and historical aerial photographs and maps of the vicinity. Forty previous cultural resource investigations have been conducted in or within 1 mile of the property, covering approximately 35 percent of the total area surrounding the property within the records search radius. Four of the 40 studies were conducted within the project area (Table 1 of the *Cultural Resources Inventory Report for the North Star 1 Project [Appendix E1 of this Initial Study]*). These studies revealed the presence of pre-contact habitation sites, and historical sites, including irrigation systems. The previous studies were conducted between 1979 and 2013.

Pedestrian Survey

An intensive pedestrian survey of the solar facility portion of the project site was conducted between December 6 and December 9, 2022. ECORP conducted an intensive pedestrian survey of the gen-tie line portion of the project site on April 11, 2024. As a result of the field surveys, ECORP identified and recorded 11 previously unrecorded archaeological resources and updated one previously-recorded resource (P-13-13072; a pre-contact habitation resource).

In addition, ECORP recorded 15 isolates: one pre-contact isolate comprising two ceramic sherds, and 14 historic-period isolates comprising section markers, refuse, and military cartridge casings and ammunition belt links.

Cultural Resources Sites within the Project Area

During the archaeological resources inventory, a total of 12 archaeological resources have been identified within the project area: 11 previously unrecorded resources and one previously recorded resource (Table 6).

Table 6. Cultural Resources within the Project Area

ECORP Site No.	Primary No.	Age/Period	Description
	P-13-13072	Pre-contact	Habitation Site
NS1-01	--	Pre-contact	Ceramic Scatter
NS1-02	--	Pre-contact	Ceramic Scatter
NS1-04	--	Pre-contact	Ceramic Scatter
NS1-07	--	Historic	Military Refuse Scatter
NS1-09	--	Pre-contact	Habitation Site
NS1-13	--	Historic	Military Refuse Scatter
NS1-14	--	Historic	Refuse Scatter
NS1-15	--	Historic	Military Refuse Scatter
NS1-16	--	Historic	Military Refuse Scatter
NS1-20	--	Historic	Canal/Lateral
NS1-GEN-1	--	Historic	Refuse Scatter

Source: Appendix E2 of this Initial Study

Evaluation for Eligibility for the NRHP and CRHR

Following the field survey, ECORP evaluated 12 archaeological resources for eligibility for the NRHP and CRHR. Evaluation efforts included a combination of subsurface testing and archival research.

Subsurface Testing

Subsurface testing consisted of a combination of augers and strategically placed shovel test pits (STPs) and TUs at or around each resource. With the goal of maximizing avoidance and preservation in place, ECORP used field methods that were minimally invasive and only included minimal excavation as needed to confirm presence or absence of cultural deposits.

With the exception of Site P-13-13072 and NS1-09, all of the other archaeological resources were negative for subsurface components. Subsurface materials recovered from subsurface testing of Site P-13-13072 included ashy soils, ground stone and flaked stone tools, ceramic sherds, faunal remains (fish and tortoise/turtle), charred seed pod fragments, and charcoal remnants. Subsurface materials recovered from subsurface testing of Site NS1-09 included faunal remains (fish and tortoise/turtle), ceramic sherds, and charcoal remnants.

Evaluation Criteria

Federal Evaluation Criteria. The cultural resources within the project area were evaluated using the NRHP eligibility criteria following the regulations implementing Section 106 of the NHPA (36 CFR Part 800). The eligibility criteria for the NRHP are as follows (36 CFR 60.4):

The quality of significance in American history, architecture, archaeology, and culture is present in districts, sites, buildings, structures, and objects of state and local importance that possess aspects of integrity of location, design, setting, materials, workmanship, feeling, association, and

- a) that are associated with events that have made a significant contribution to the broad patterns of our history; or
- b) that are associated with the lives of persons significant in our past; or
- c) that embody the distinctive characteristics of a type, period, or method of construction, or that represent the work of a master, or that possess high artistic values, or that represent a significant and distinguishable entity whose components may lack individual distinction; or
- d) that have yielded, or may be likely to yield, information important in prehistory or history.

In addition, the resource must be at least 50 years old, except in exceptional circumstances (36 CFR 60.4).

State Evaluation Criteria. Under State law (CEQA), cultural resources are evaluated using CRHR eligibility criteria to determine whether any of the sites are Historical Resources, as defined by CEQA. CEQA requires that impacts to Historical Resources be identified and, if the impacts would be significant, that mitigation measures to reduce the impacts be applied.

A Historical Resource is a resource that:

- 1) is listed in or has been determined eligible for listing in the CRHR by the State Historical Resources Commission;
- 2) is included in a local register of historical resources, as defined in PRC 5020.1(k);
- 3) has been identified as significant in a historical resources survey, as defined in PRC 5024.1(g); or



- 4) is determined to be historically significant by the CEQA lead agency CCR Title 14, §15064.5(a)]. In making this determination, the CEQA lead agency usually applies the CRHR eligibility criteria.

The eligibility criteria for the CRHR (CCR Title 14, § 4852(b)) state that a resource is eligible if:

- 1) it is associated with events that have made a significant contribution to the broad patterns of local or regional history, or the cultural heritage of California or the U.S.;
- 2) it is associated with the lives of persons important to local, California, or national history.
- 3) it embodies the distinctive characteristics of a type, period, region, or method of construction, or represents the work of a master or possesses high artistic values; or
- 4) it has yielded, or has the potential to yield, information important to the prehistory or history of the local area, California, or the Nation.

In addition, the resource must retain integrity. Integrity is evaluated with regard to the retention of location, design, setting, materials, workmanship, feeling, and association (CCR Title 14, § 4852(c)).

Evaluation Summary. The cultural resources within the project area were evaluated using the NRHP and CHRH eligibility criteria listed above. Table 7 summarizes the NRHP and CHRH eligibility recommendations of the cultural resources within the project area.

Table 7. CRHR/NRHP Eligibility of Cultural Resources within Project Area

ECORP Site No.	Primary No.	Age/Period	Description	CRHR/NRHP Eligibility
	P-13-13072	Pre-contact	Habitation Site	Eligible for CRHR and NRHP
NS1-01	--	Pre-contact	Ceramic Scatter	Not eligible
NS1-02	--	Pre-contact	Ceramic Scatter	Not eligible
NS1-04	--	Pre-contact	Ceramic Scatter	Not eligible
NS1-07	--	Historic	Military Refuse Scatter	Not eligible
NS1-09	--	Pre-contact	Habitation Site	Eligible for CRHR and NRHP
NS1-13	--	Historic	Military Refuse Scatter	Not eligible
NS1-14	--	Historic	Refuse Scatter	Not eligible
NS1-15	--	Historic	Military Refuse Scatter	Not eligible
NS1-16	--	Historic	Military Refuse Scatter	Not eligible
NS1-20	--	Historic	Canal/Lateral	Not eligible
NS1-GEN-1	--	Historic	Refuse Scatter	Not eligible

Source: Appendix E2 of this Initial Study

- Site P-13-13072 is a pre-contact habitation site with ashy soils, ground stone and flaked stone tools, ceramic sherds, faunal remains (fish and tortoise/turtle), charred seed pod fragments, and charcoal remnants. Subsurface testing of the portion of the resource within the Project Area has demonstrated that there is still an intact subsurface component. ECORP could not locate any information to indicate that this resource is associated with important events in history or prehistory (NRHP/CRHR

A/1). Though the ceramic sherds are temporally diagnostic of the Late Prehistoric period, there is nothing to indicate that this resource is associated with important persons in history or prehistory (NRHP/CRHR B/2). This habitation site was not designed or constructed in a planned manner; therefore, it cannot be considered a work of a master or represent a specific type or period (NRHP/CRHR C/3). The pre-contact ceramics, lithic artifacts, faunal and charred vegetal remains, and intact subsurface component indicate that this resource does have the necessary cultural material with which to address the Activities and Site Function, Subsistence Patterns, and Chronology and Temporal Patterning research questions (NRHP/CRHR D/4). Resource P-13-13072 is evaluated as eligible under Criterion D/4 for the NRHP/CRHR and is considered a Historical Resource as defined by CEQA.

- NS1-09 is a pre-contact habitation site that is located along a terraced shoreline of Lake Cahuilla. Subsurface testing of the resource within the Project Area has demonstrated that there is still an intact subsurface component. ECORP could not locate any information to indicate that this resource is associated with important events in history or prehistory (NRHP/CRHR A/1). While the ceramic sherds are temporally diagnostic of the Late Prehistoric period, there is nothing to indicate that this resource is associated with important persons in history or prehistory (NRHP/CRHR B/2). This habitation site was not designed or constructed in a planned manner; therefore, it cannot be considered a work of a master or represent a specific type or period (NRHP/CRHR C/3). The pre-contact ceramics, lithic artifacts, faunal remains, charcoal fragments, and intact subsurface component indicate that this resource does have the necessary cultural material with which to address the Activities and Site Function, Subsistence Patterns, and Chronology and Temporal Patterning research questions (NRHP/CRHR D/4). Resource NS1-09 is evaluated as eligible under Criterion D/4 for the NRHP/CRHR and is considered a Historical Resource as defined by CEQA.
- Isolates are unassociated artifacts or minor features that represent either accidental inclusion or are otherwise disconnected from the human activity that produced them. Isolates typically do not individually contribute to the broad patterns of history because they cannot be connected to a particular event (NRHP Criterion A/CRHR Criterion 1). Isolates are similarly difficult to associate with specific individuals due to their lack of association with archaeological or historical sites, and generally no information exists in the archival record to associate isolates with important individuals in history (NRHP Criterion B/CRHR Criterion 2). Isolates do not embody the distinctive characteristics of a type, period, region, or method of construction, or represent the work of an important creative individual, or possess high artistic values (NRHP Criterion C/CRHR Criterion 3). Finally, isolates in general do not provide important information in history or prehistory (NRHP Criterion D/CRHR Criterion 4). Therefore, the isolates identified during the technical study do not meet the eligibility criteria for inclusion in the NRHP or CRHR as an individual resource. These isolated finds do not contribute to any known or suspected historic districts; and are neither considered to be Historic Properties for the purpose of Section 106 NHPA, nor Historical Resources under CEQA.

Impact Analysis

As discussed above, Site P-13-13072 and NS1-09 are evaluated as eligible for the NRHP/CRHR and considered Historical Resources under CEQA. Construction activities associated with the proposed project will include ground disturbing actions that could impact the abovementioned NRHP/CRHR eligible resources. To the maximum extent feasible, the project applicant will design the project to avoid these resources. However, if avoidance is not feasible, the proposed project has the potential to impact these resources and cause a

substantial adverse change in the significance of a historical resource pursuant to §15064.5. This potential impact is considered significant. Implementation of Mitigation Measures CR-1 through CR-3 would reduce the potential impact to a level less than significant.

Mitigation Measures:

- CR-1 Cultural Resources Management Plan.** The project applicant will develop a cultural resources management plan (CRMP) to outline the process for compliance with applicable cultural resources laws, management of resources during operation, and consideration of the effect of decommissioning. The CRMP shall include the following: identification of California Native American tribes, identification of long and short term management goals for cultural resources within the project area, description of measures to avoid, minimize, and reduce significant impacts to cultural resources (including both historical and archaeological resources), unanticipated discovery procedures, monitoring needs, data recovery of significant cultural resources where avoidance is not possible, curation procedures for recovered artifacts, anticipated personnel requirements and qualifications. The CRMP shall specifically address Site P-13-13072 and NS1-09. The draft CRMP shall be prepared by a registered professional archaeologist and reviewed and approved by the County of Imperial Planning and Development Services Department.
- CR-2 Contractor Awareness Training.** Prior to project construction, a Contractor Awareness Training Program shall be developed and implemented to train equipment operators about cultural resources. The program shall be designed to inform construction personnel about: federal and state regulations pertaining to cultural resources and tribal cultural resources; the subsurface indicators of resources that shall require a work stoppage; procedures for notifying the lead agency of any occurrences; project-specific requirements and mitigation measures; and enforcement of penalties and repercussions for non-compliance with the program. The training shall be prepared by a qualified professional archaeologist and may be provided either through a brochure, video, or in-person tailgate meeting, as determined appropriate by the archaeologist.
- Training shall be provided to all construction supervisors, forepersons, and operators of ground disturbing equipment. All personnel shall be required to sign a training roster. The construction manager is responsible for ensuring that all required personnel receive the training. The construction manager shall provide a copy of the signed training roster to the Imperial County Planning and Development Services Department as proof of compliance.
- CR-3 Archaeological Monitoring.** Prior to the start of construction, the project applicant shall retain a qualified professional archaeologist, who meets or exceeds the Secretary of the Interior Professional Qualifications Standards as an archaeologist and a traditionally and culturally affiliated Native American Monitor, to monitor all ground-disturbing activities associated with project construction. Monitoring is not required for placement of equipment or fill inside excavations that were monitored, above-ground construction activities, or redistribution of soils that were previously monitored (such as the return of stockpiles to use in backfilling).
- In the event of the discovery of previously unidentified archaeological materials, the contractor shall immediately cease all work activities within approximately 100 feet of the discovery. After cessation of excavation, the contractor shall immediately contact the Imperial County Department of

Planning and Development Services. Except in the case of cultural items that fall within the scope of the Native American Grave Protection and Repatriation Act, the discovery of any cultural resource within the project area shall not be grounds for a “stop work” notice or otherwise interfere with the project’s continuation except as set forth in this paragraph.

In the event of an unanticipated discovery of archaeological materials during construction, the qualified professional archaeologist shall evaluate the significance of the materials prior to resuming any construction related activities in the vicinity of the find. If the qualified archaeologist determines that the discovery constitutes a significant resource under CEQA and it cannot be avoided, the applicant shall implement an archaeological data recovery program.

- b) **Less than Significant Impact with Mitigation Incorporated.** The subsurface testing at P-13-13072 and NS1-09 resulted in evidence of subsurface deposits. Archival research suggests that for resources similar to NS1-20, historic-era resources would not likely be deeply buried, but instead, would manifest themselves on the surface (and therefore be detectable through standard survey). For pre-contact archaeological resources, the soil types present in the project area and immediate vicinity are gravelly, well-drained, deep, and loamy, which is characteristic of the alluvium sediments that frame the extent of ancient Lake Cahuilla. Pre-contact archaeological resources could have been buried during alluvial events in the past.

Due to the presence of alluvium along successive Lake Cahuilla shorelines, and given the likelihood for pre-contact archaeological resources to be located along such shorelines, the project area has the potential for buried pre-contact archaeological resources. There is a high potential for buried pre-contact cultural material along the Lake Cahuilla shorelines because pre-contact resources in this region are known to occur along shorelines, rivers, creeks, and drainages. Therefore, there remains a possibility that unanticipated subsurface discoveries may arise during project construction. This potential impact is considered significant. Implementation of Mitigation Measures CR-2 and CR-3 would reduce potential impacts to a level less than significant.

Mitigation Measures:

CR-2 Contractor Awareness Training (as described above).

CR-3 Archaeological Monitoring (as described above).

- c) **Less than Significant Impact with Mitigation Incorporated.** During the construction of the proposed project, grading, excavation and trenching will be required. Although the potential for encountering subsurface human remains within the project site is low, there remains a possibility that human remains are present beneath the ground surface, and that such remains could be exposed during construction. The potential to encounter human remains is considered a significant impact. Mitigation Measure CR-4 would ensure that the potential impact on previously unknown human remains does not rise to the level of significance pursuant to CEQA.

Mitigation Measure:

CR-4 If subsurface deposits believed to be human in origin are discovered during construction, all work must halt within a 100-foot radius of the discovery. A qualified professional archaeologist who meets the Secretary of the Interior’s Standards for prehistoric and historic archaeology and is familiar with the resources of the region, shall be retained to evaluate the significance of the find, and shall have the authority to modify the no work radius as appropriate, using professional judgment. The following notifications shall apply, depending on the nature of the find:

If the find includes human remains, or remains that are potentially human, the professional archaeologist shall ensure reasonable protection measures are taken to protect the discovery from disturbance (AB 2641). The archaeologist shall notify the Imperial County Coroner (per § 7050.5 of the Health and Safety Code). The provisions of § 7050.5 of the California Health and Safety Code, § 5097.98 of the California PRC, and AB 2641 will be implemented.

If the Coroner determines the remains are Native American and not the result of a crime scene, the Coroner will notify the NAHC, which then will designate a Native American Most Likely Descendant (MLD) for the project (§ 5097.98 of the PRC). The designated MLD will have 48 hours from the time access to the property is granted to make recommendations concerning treatment of the remains. If the landowner does not agree with the recommendations of the MLD, the NAHC may mediate (§ 5097.94 of the PRC). If no agreement is reached, the landowner must rebury the remains where they will not be further disturbed (§ 5097.98 of the PRC). This will also include either recording the site with the NAHC or the appropriate Information Center; using an open space or conservation zoning designation or easement; or recording a reinternment document with the county in which the property is located (AB 2641). Work may not resume within the no-work radius until the Imperial County Planning and Development Services Department, through consultation as appropriate, determine that the treatment measures have been completed to their satisfaction.

VI. Energy

Environmental Issue Area:	Potentially Significant Impact	Less than Significant with Mitigation Incorporated	Less Than Significant Impact	No Impact
<i>Would the project:</i>				
a) Result in potentially significant environmental impact due to wasteful, inefficient, or unnecessary consumption of energy resources, during project construction or operation?	<input type="checkbox"/>	<input type="checkbox"/>	<input checked="" type="checkbox"/>	<input type="checkbox"/>
b) Conflict with or obstruct a state or local plan for renewable energy or energy efficiency?	<input type="checkbox"/>	<input type="checkbox"/>	<input checked="" type="checkbox"/>	<input type="checkbox"/>

Impact Analysis

The following information is summarized from the *Energy Consumption Assessment* prepared by ECORP. This report is provided as Appendix F of this Initial Study.

- a) **Less than Significant Impact.** The proposed project would provide energy storage. The use of energy associated with the proposed project includes both construction and operational activities. The project proposes the construction of a 50-MW alternating current solar PV energy generation system with an integrated 75 MW battery storage system. Operation of the proposed project would not result in the consumption of electricity or natural gas and thus, would not contribute to County wide usage. Instead, the project would directly support the RPS goal for increasing the percentage of electricity procured from renewable sources.

The two sources of energy associated with the project includes the equipment fuel necessary for construction and the automotive fuel necessary for ongoing maintenance activities. For the purposes of this analysis, project increases in construction and automotive fuel consumption

are compared with the countywide fuel consumption in 2021 (Table 8), the most recent full year of data. This analysis conservatively assumes that all of the automobile trips projected to arrive at the project site during operations would be new to Imperial County.

Table 8. Automotive Fuel Consumption in Imperial County 2016-2021

Year	Total Fuel Consumption
2021	216,105,185
2020	194,711,440
2019	217,988,585
2018	218,114,145
2017	220,106,315
2016	215,751,500

Source: Appendix F of this Initial Study

Energy and fuel consumption associated with the proposed project is summarized in Table 9. The fuel expenditure necessary to construct the solar facility and infrastructure would be temporary, lasting only as long as project construction. As shown in Table 9, the project's gasoline fuel consumption during the one-time construction period is estimated to be 104,828 gallons during 2023 construction and 34,581 gallons during 2024 construction. This would increase the annual countywide gasoline fuel use associated with offroad equipment in the County 0.048 percent and 0.016 percent, respectively.

Table 9. Proposed Project Energy and Fuel Consumption

Energy Type	Annual Energy Consumption	Percentage Increase Countywide
Facility Electrical and Natural Gas Consumption		
Electricity Consumption	0 kilowat-hours	0.00 percent
Natural Gas	0 therms	0.00 percent
Automotive Fuel Consumption		
Project Construction 2023	104,828 gallons	0.048 percent
Project Construction 2024	34,581 gallons	0.016 percent
Project Operations	3,838 gallons	0.001 percent

Source: Appendix F of this Initial Study

Notes: The project increases in electricity and natural gas consumption are compared with all uses in Imperial County in 2020, the latest data available. The project increase in automotive fuel are compared with the countywide fuel consumption in 2021, the most recent full year of data.

As shown in Table 9, project construction would have a nominal effect on local and regional energy supplies. Additionally, construction equipment fleet turnover and increasingly stringent state and federal regulations on engine efficiency combined with state regulations limiting engine idling times and requiring recycling of construction debris, would further reduce the amount of transportation fuel demand during project construction. For these reasons, it is expected that construction fuel consumption associated with the project would not be any more inefficient, wasteful, or unnecessary than other similar development projects of this nature.

Once construction is completed the project will be remotely controlled. No employees would be based at the project site. The only operational emissions associated with the project would be associated with motor vehicle use for routine maintenance work, and site security as well as panel upkeep and cleaning. Four heavy-duty truck vehicle trips per day for routine maintenance work, site security, and trucking in water was assumed. This is a conservative estimate as most days would require no operational related vehicle trips. As shown Table 9, this would estimate to a consumption of approximately 3,838 gallons of automotive fuel per year, which would increase the annual countywide automotive fuel consumption by 0.001



percent. Fuel consumption associated with ongoing maintenance activities would not be considered inefficient, wasteful, or unnecessary in comparison to other similar developments in the region.

Based on these considerations, the proposed project would not result in potentially significant environmental impacts due to wasteful, inefficient, or unnecessary consumption of energy resources, during project construction or operation. Therefore, this is considered a less than significant impact.

- b) **Less than Significant Impact.** As described above, implementation and operation of the project would promote the use of renewable energy and contribute incrementally to the reduction in demand for fossil fuel use for electricity-generating purposes and help California meet its RPS. Additionally, the project would be consistent with the County’s General Plan Conservation and Open Space Element, Objective 9.2 which encourages renewable energy developments. The proposed project would directly support state and local plans for renewable energy development and would be considered a less than significant impact.

VII. Geology and Soils

Environmental Issue Area:	Potentially Significant Impact	Less than Significant with Mitigation Incorporated	Less Than Significant Impact	No Impact
<i>Would the project:</i>				
a) Directly or indirectly cause potential substantial adverse effects, including the risk of loss, injury or death involving:				
i. Rupture of a known earthquake fault, as delineated on the most recent Alquist-Priolo Earthquake Fault Zoning Map issued by the State Geologist for the area or based on other substantial evidence of a known fault? Refer to Division of Mines and Geology Special Publication 42?	<input type="checkbox"/>	<input type="checkbox"/>	<input type="checkbox"/>	<input checked="" type="checkbox"/>
ii. Strong seismic ground shaking?	<input type="checkbox"/>	<input type="checkbox"/>	<input checked="" type="checkbox"/>	<input type="checkbox"/>
iii. Seismic-related ground failure, including liquefaction?	<input type="checkbox"/>	<input type="checkbox"/>	<input checked="" type="checkbox"/>	<input type="checkbox"/>
iv. Landslides?	<input type="checkbox"/>	<input type="checkbox"/>	<input checked="" type="checkbox"/>	<input type="checkbox"/>
b) Result in substantial soil erosion or the loss of topsoil?	<input type="checkbox"/>	<input type="checkbox"/>	<input checked="" type="checkbox"/>	<input type="checkbox"/>
c) Be located on a geologic unit or soil that is unstable, or that would become unstable as a result of the project and potentially result in on- or off-site landslide, lateral spreading, subsidence, liquefaction, or collapse?	<input type="checkbox"/>	<input type="checkbox"/>	<input checked="" type="checkbox"/>	<input type="checkbox"/>

d) Be located on expansive soil, as defined in Table 18-1B of the Uniform Building Code (1994), creating substantial direct or indirect risk to life or property?	<input type="checkbox"/>	<input type="checkbox"/>	<input checked="" type="checkbox"/>	<input type="checkbox"/>
e) Have soils incapable of adequately supporting the use of septic tanks or alternative wastewater disposal systems where sewers are not available for the disposal of wastewater?	<input type="checkbox"/>	<input type="checkbox"/>	<input type="checkbox"/>	<input checked="" type="checkbox"/>
f) Directly or indirectly destroy a unique paleontological resource or site or unique geologic feature?	<input type="checkbox"/>	<input checked="" type="checkbox"/>	<input type="checkbox"/>	<input type="checkbox"/>

Impact Analysis

The following information is summarized from the *Geotechnical Report* prepared by Landmark Consultants, Inc (Landmark). This report is provided as Appendix G of this Initial Study.

- ai) **No Impact.** The project site is located in a seismically active Imperial valley with numerous mapped faults traversing the region. According to the *Geotechnical Report*, the project site is not located within or adjacent to any earthquake fault zone as delineated on the most recent Alquist Priolo Earthquake Zoning Map. The nearest zoned fault is the San Andreas Fault located approximately 10.2 miles northwest of the project site (Appendix G of this Initial Study). The proposed project would not result in the construction of any structure intended for human occupancy and all structures and onsite facilities would be designed in accordance with the most recent California Building Code (CBC). Therefore, no impact would occur.
- a ii) **Less than Significant Impact.** Southern California is a seismically active region; therefore it is highly likely that regional earthquakes would occur that could affect the proposed project. As previously mentioned above, no active faults are underlying the project site, however, the San Andreas Fault and its associated earthquake fault zone is located approximately 10.2 miles northwest of the project site. All structures and on-site facilities would be designed in accordance with the most recent CBC for peak site ground acceleration. Since the design and construction of the project would be required to conform to the specific mandated structural design requirements to protect against strong seismic shaking, the potential impacts due to strong seismic ground shaking are considered to be a less than significant impact.
- a iii) **Less than Significant Impact.** Four conditions are generally required for liquefaction to occur, including: 1) saturated soil, 2) loosely packed soil, 3) relatively cohesionless soil, and 4) groundshaking of sufficient intensity must occur to trigger the mechanism. All four conditions may exist to some degree at the project site. Liquefaction is unlikely to be a potential hazard on-site due to the lack of saturated granular soil and the estimated depth to groundwater (greater than 50 feet) (Appendix G of this Initial Study).

As required by the County and in accordance with local and state building code requirements, any proposed development would be required to complete a geotechnical evaluation of any onsite hazards. As a standard condition of project approval, the proposed project would be constructed in accordance with the most current CBC and Imperial County Building Code to minimize or avoid the potential hazard of liquefaction. A less than significant impact is identified for this issue area.
- a iv) **Less than Significant Impact.** The project site is located in a relatively flat portion of Imperial County and is not identified as an area at risk of landslide (Appendix G of this Initial Study). Therefore, the impact associated with landslides is considered less than significant.

- b) **Less than Significant Impact.** Soil erosion and loss of topsoil could result during construction as grading and construction can loosen surface soils and make soils susceptible to wind and water movement across the surface. Construction activities are regulated under the National Pollutant Discharge Elimination System (NPDES) General Permit for Discharges of Storm Water Runoff Associated with Construction Activity (General Construction Permit) which covers stormwater runoff requirements for projects where the total amount of ground disturbance during construction exceeds one acre. The proposed project would be required to comply with the General Construction Permit because ground disturbance would exceed one acre. Coverage under a General Construction Permit requires the preparation of a SWPPP and submittal of a Notice of Intent (NOI) to comply with the General Construction Permit. The SWPPP would identify best management practices (BMPs) that would reduce any impacts associated with soil erosion or loss of topsoil. Therefore, this impact is considered less than significant.

- c) **Less than Significant Impact.**

Landslides. As described in Response VII. aiv) above, the project site is located in a relatively flat portion of Imperial County and is not identified as an area at risk of landslide. Therefore, the impact associated with landslides is considered less than significant.

Lateral Spreading. The potential for lateral spreading to occur on the project site has not yet been determined. Additional geotechnical investigation would be required in order to assess the risk of lateral spreading to occur on the project site. As required by the County and in accordance with local and state building code requirements, any proposed development would be required to complete a geotechnical evaluation of any onsite hazards. As a standard condition of project approval, the proposed project would be constructed in accordance with the most current CBC and Imperial County Building Code to minimize or avoid the potential hazard of liquefaction and lateral spreading. A less than significant impact is identified for this issue area.

Subsidence. The potential for subsidence to occur on the project site has not yet been determined. Additional geotechnical investigation would be required in order to assess the risk of subsidence to occur on the project site. As required by the County and in accordance with local and state building code requirements, any proposed development would be required to complete a geotechnical evaluation of any onsite hazards. As a standard condition of project approval, the proposed project would be constructed in accordance with the most current CBC and Imperial County Building Code to minimize or avoid the potential hazard of subsidence. A less than significant impact is identified for this issue area.

Liquefaction. As described in Response VII. aiii) above, liquefaction is unlikely to be a potential hazard on-site due to the lack of saturated granular soil and the estimated depth to groundwater (greater than 50 feet). As a standard condition of project approval, the proposed project would be constructed in accordance with the most current CBC and Imperial County Building Code to minimize or avoid the potential hazard of liquefaction. A less than significant impact is identified for this issue area.

Collapse. The potential for collapse to occur on the project site was determined to be very low due to the cohesive nature of the subsurface soils (Appendix G of this Initial Study). As a standard condition of project approval, the proposed project would be constructed in accordance with the most current CBC and Imperial County Building Code to minimize or avoid the potential hazard of collapse. A less than significant impact is identified for this issue area.

- d) **Less than Significant Impact.** In general, much of the near surface soils within the project site consist of silty clay and clays having a moderate to high expansion potential. Unless properly mitigated, shrink-swell soils could exert additional pressure on buried structures producing shrinkage cracks that could allow water infiltration and compromise the integrity of backfill material. These conditions could be worsened if structural facilities are constructed directly on expansive soil materials.

As required by the County and in accordance with local and state building code requirements, any proposed development would be required to complete a geotechnical evaluation of any onsite hazards. As a standard condition of project approval, the proposed project would be constructed in accordance with the most recent CBC and Imperial County Building Code to minimize or avoid the potential hazard of expansive soil. A less than significant impact is identified for this issue area.

- e) **No Impact.** The proposed project would not require the use of septic systems or alternative wastewater systems to accommodate wastewater needs. Therefore, no impact is identified for this issue area.
- f) **Less than Significant Impact with Mitigation Incorporated.** Many paleontological fossil sites are recorded in Imperial County and have been discovered during construction activities. Paleontological resources are typically impacted when earthwork activities, such as mass excavation cut into geological deposits (formations) with buried fossils. One area in which paleontological resources appear to be concentrated in this region is the shoreline of ancient Lake Cahuilla, which would have encompassed the present-day Salton Sea. The lake covered much of the Imperial Valley and created an extensive lacustrine environment. Lake Cahuilla experienced several fill recession episodes before it finally dried up about 300 years ago. In 1905, the Colorado River overflowed into the Salton Basin creating the present-day Salton Sea.

The project site is located in the Imperial Valley which is directly underlain by geologic units comprised of quaternary lake deposits of the ancient Lake Cahuilla. Lakebed deposits of ancient Lake Cahuilla have yielded fossil remains from numerous localities in Imperial Valley. These include extensive freshwater shell beds, fish, seeds, pollen, diatoms, foraminifera, sponges, and wood. Lake Cahuilla deposits have also yielded vertebrate fossils, including teeth and bones of birds, horses, bighorn sheep, and reptiles. Therefore, the paleontological sensitivity of these lakebed deposits within the project site are considered to be high.

Impacts on any surface or near-surface level paleontological resources may occur because of grading and disturbance of the area. Even relatively shallow excavations in the Lake Cahuilla beds exposed in the project site may encounter significant vertebrate fossil remains. Therefore, this potential impact is considered a significant impact. Mitigation Measure GEO-1 would ensure that the potential impacts on paleontological resources do not rise to the level of significance pursuant to CEQA. Implementation of Mitigation Measure GEO-1 would reduce the impact on paleontological resources to a level less than significant.

Mitigation Measure

- GEO-1** In the event that unanticipated paleontological resources or unique geologic resources are encountered during ground-disturbing activities, work must cease within 50 feet of the discovery and a paleontologist shall be hired to assess the scientific significance of the find. The consulting paleontologist shall have knowledge of local paleontology and the minimum levels of experience and expertise as defined by the Society of Vertebrate Paleontology's Standard Procedures (2010) for the Assessment and Mitigation of Adverse Impacts to Paleontological Resources. If any paleontological resources or unique geologic features are encountered within the project site, the consulting paleontologist shall prepare a paleontological Treatment and Monitoring Plan to include the methods that will be used to protect paleontological resources that may exist within the project site, as well as procedures for monitoring, fossil preparation and identification, curation of specimens into an accredited repository, and preparation of a report at the conclusion of the monitoring program.



VIII. Greenhouse Gas Emissions

Environmental Issue Area:	Potentially Significant Impact	Less than Significant with Mitigation Incorporated	Less Than Significant Impact	No Impact
Would the project:				
a) Generate greenhouse gas emissions, either directly or indirectly, that may have a significant impact on the environment?	<input type="checkbox"/>	<input type="checkbox"/>	<input checked="" type="checkbox"/>	<input type="checkbox"/>
b) Conflict with an applicable plan, policy, or regulation adopted for the purpose of reducing the emissions of greenhouse gases?	<input type="checkbox"/>	<input type="checkbox"/>	<input checked="" type="checkbox"/>	<input type="checkbox"/>

Impact Analysis

The following information is summarized from the *Air Quality and Greenhouse Gas Emissions Assessment* prepared by ECORP. This report is provided as Appendix B of this Initial Study.

- a) **Less than Significant Impact.** Prominent greenhouse gases (GHGs) contributing to the greenhouse effect are carbon dioxide (CO₂), methane (CH₄), and nitrogen oxide (N₂O). Human-caused emissions of these GHGs in excess of natural ambient concentrations are believed to be responsible for intensifying the greenhouse effect and leading to a trend of unnatural warming of the earth’s climate, known as global climate change or global warming.

The project site is located within the Salton Sea Air Basin, regulated by the ICAPCD. To date the ICAPCD has not adopted GHG emission significance thresholds applicable to potential development. Section 15064.7(c) of the CEQA Guidelines specifies that “[w]hen adopting or using thresholds of significance, a lead agency may consider thresholds of significance previously adopted or recommended by other public agencies, or recommended by experts, provided the decision of the lead agency to adopt such thresholds is supported by substantial evidence” (14 CCR 15064.7(c)). Thus, in the absence of any GHG emissions significance thresholds, the projected emissions are compared to the Mojave Desert Air Quality Management District (MDAQMD) numeric threshold of 100,000 metric tons of CO₂e annually. While significance thresholds used in the Mojave Desert Air Basin are not binding on the ICAPCD or County of Imperial, they are instructive as a comparative metric of the project’s potential GHG impact. This threshold is also appropriate as the MDAQMD GHG thresholds were formulated based on similar geography and climate patterns as found in Imperial County. Therefore, the 100,000-metric ton of CO₂e threshold is appropriate for this analysis.

The following analysis is broken out by a discussion of potential impacts during construction and operation of the project. The CalEEMod 2020.4.0 air quality model was used to calculate the GHG emissions associated with construction and operation of the proposed project. The CalEEMod worksheets are included in Appendix B of this Initial Study.

Construction

Construction-related activities that would generate GHG emissions include worker commute trips, haul trucks carrying supplies and materials to and from the project site, and off-road construction equipment (e.g., dozers, loaders, and excavators).

Table 10 summarizes the specific construction-generated GHG emissions that would result from construction of the project. Consistent with South Coast Air Quality Management

(SCAQMD) recommendations, project construction GHG emissions have been amortized over the expected life of the project, which is considered to be up to 30 years. As shown in Table 10, the project would generate approximately 1,064 metric tons of CO₂e in the first year of construction and 351 metric tons in the second year of construction. Therefore, construction-related GHG emissions would not exceed the significance threshold of 100,000 metric tons of CO₂e per year and impacts would be considered less than significant.

Table 10. Construction-Related GHG Emissions

Emissions Source	GHG Emissions (Metric Tons/Year)
Construction Year One	1,064
Construction Year Two	351
<i>Significance Threshold</i>	100,000
Exceed Significance Threshold?	No

Source: Appendix B of this Initial Study

Operation

Operation of the project would result in an increase in GHG emissions solely associated with motor vehicle trips. Once the proposed project is operational, very few vehicular trips would be expected. The project would be an unmanned facility that would be operated remotely. Therefore, the project would not generate routine daily trips. Occasional maintenance trips would be required for panel washing. As shown in Table 11, the project would generate approximately 63 metric tons of CO₂e per year during operations, which is below MDAQMD's significance threshold of 100,000 metric tons of CO₂e annually. Therefore, the project's GHG impact would be less than significant.

Table 11. Operational-Related GHG Emissions

Emission Source	GHG Emissions (MT CO ₂ e)
Area Source	0
Energy	0
Mobile	63
Waste	0
Water	0
Total	63
Significance Threshold	100,000
Exceeds Significance Threshold?	No

Source: Appendix B of this Initial Study

Notes: Operational emissions account for four heavy-duty truck vehicle trips per day. It is noted that this is a conservative estimate and many days will have no operational related vehicle trips.

Once construction is complete, the project would be a producer of renewable energy, which generates substantially less GHG emissions compared with the more common types of fossil-fueled energy generation facilities. shows the emissions that would potentially be displaced by the proposed project. This estimate only includes that associated with the combustion of fossil fuels; it does not include the vehicle trips associated with the project's operations, and it does not include operational employee trips associated with natural gas or coal combustion nor the emissions associated with extracting and transporting those power sources. In addition, this estimate only includes the displacement of that portion of the California market that comes from fossil fuels and does not include the approximate 50 percent of the California electricity generated by non-combustion sources (wind, solar, nuclear, hydro-electric). As shown in Table 12, the project would potentially displace



approximately 26,610 metric tons of CO₂e per year, and approximately 798,298 metric tons of CO₂e over the course of 30 years. While the project would emit some GHG emissions during construction and operations, the contribution of renewable resource energy production to meet the goals of the Renewable Portfolio Standard (Scoping Plan Measure E-3) would result in a net cumulative reduction of GHG emissions. The short-term generation of GHG emissions would be more than offset by the GHG emission reductions associated with solar-generated energy during operation. Therefore, the project’s GHG impact would be less than significant.

Table 12. Proposed Project Displaced GHG Emissions

	Emissions (Metric Tons)			
	CO ₂	CH ₄	N ₂ O	CO ₂ e
Emissions Displaced Annually (Metric Tons)				
Displaced Natural Gas-Source Emissions	23,792	0.00	0.00	23,792
Displaced Coal-Source Emissions	2,813	0.019	0.014	2,818
Total	26,605	0.019	0.014	26,610
Emissions Displaced over 30 Years (Metric Tons)				
Total	798,154	0.55	0.41	798,298

Source: Appendix B of this Initial Study

- b) **Less than Significant Impact.** As discussed in Response VIII. a) above, the proposed project would generate a relatively small amount of GHG emissions. The proposed project-generated GHG emissions would not exceed the MDAQMD significance thresholds, which were prepared with the purpose of complying with statewide GHG-reduction efforts. While the project would emit some GHG emissions during construction and a very small amount during operations, the contribution of renewable resource energy production to meet the goals of the Renewable Portfolio Standard (Scoping Plan Measure E-3) would result in a net cumulative reduction of GHG emissions, a key environmental benefit. Scoping Plan Measure E-3, Renewable Portfolio Standard, of the Climate Change Scoping Plan requires that all investor-owned utility companies generate 60 percent of their energy demand from renewable sources by the year 2030. Therefore, the short-term minor generation of GHG emissions during construction, which is necessary to create this new, low-GHG emitting power-generating facility, as well as the negligible amount generated during ongoing maintenance operations, would be more than offset by GHG emission reductions associated with solar-generated energy during operation. The proposed project would reduce GHG emissions in a manner consistent with SB 32 and other California GHG-reducing legislation by creating a new source of solar power to replace the current use of fossil-fuel power and reduce GHG emissions power generation and use. Therefore, the proposed project would not conflict with any applicable plan, policy, or regulation adopted for reducing the emissions of GHGs and a less than significant impact would occur.

IX. Hazards and Hazardous Materials

Environmental Issue Area:	Potentially Significant Impact	Less than Significant with Mitigation Incorporated	Less Than Significant Impact	No Impact
Would the project:				
a) Create a significant hazard to the public or the environment through the routine transport, use, or disposal of hazardous materials?	<input type="checkbox"/>	<input type="checkbox"/>	<input checked="" type="checkbox"/>	<input type="checkbox"/>
b) Create a significant hazard to the public or the environment through reasonably foreseeable upset and accident conditions involving the likely release of hazardous materials into the environment?	<input type="checkbox"/>	<input type="checkbox"/>	<input checked="" type="checkbox"/>	<input type="checkbox"/>
c) Emit hazardous emissions or handle hazardous or acutely hazardous materials, substances, or waste within one-quarter mile of an existing or proposed school?	<input type="checkbox"/>	<input type="checkbox"/>	<input type="checkbox"/>	<input checked="" type="checkbox"/>
d) Be located on a site which is included on a list of hazardous materials sites compiled pursuant to Government Code Section 65962.5 and, as a result, would it create a significant hazard to the public or the environment?	<input type="checkbox"/>	<input type="checkbox"/>	<input type="checkbox"/>	<input checked="" type="checkbox"/>
e) For a project located within an airport land use plan or, where such a plan has not been adopted, within two miles of a public airport or public use airport, would the project result in a safety hazard or excessive noise for people residing or working in the project area?	<input type="checkbox"/>	<input type="checkbox"/>	<input type="checkbox"/>	<input checked="" type="checkbox"/>
f) Impair implementation of or physically interfere with an adopted emergency response plan or emergency evacuation plan?	<input type="checkbox"/>	<input type="checkbox"/>	<input type="checkbox"/>	<input checked="" type="checkbox"/>
g) Expose people or structures, either directly or indirectly, to a significant risk of loss, injury, or death involving wildland fires?	<input type="checkbox"/>	<input type="checkbox"/>	<input type="checkbox"/>	<input checked="" type="checkbox"/>

Impact Analysis

The following information is summarized from the *Phase I Environmental Site Assessment (Phase I ESA)* prepared by GS Lyon Consultants, Inc. This report is provided as Appendix H of this Initial Study.

- a) **Less than Significant Impact.** Vehicles and equipment used for construction would contain or require the temporary use of potentially hazardous substances, such as fuels, lubricating oils, and hydraulic fluid. Hazardous substances would be stored in transportable containment trailers

at locations within the construction staging area to minimize potential for accidental releases and/or spills.

Transportation of hazardous materials relating to the battery system includes electrolyte and graphite and would occur during construction, operation (if replacement of batteries is needed) and decommissioning (removal of the batteries). All of these various materials would be transported and handled in compliance with DTSC regulations. Therefore, the likelihood of an accidental release during transport or residual contamination following accidental release is not anticipated.

Lithium-ion batteries used in the storage system contain cobalt oxide, manganese dioxide, nickel oxide, carbon, electrolyte, and polyvinylidene fluoride. Of these chemicals, only electrolyte should be considered hazardous, inflammable and could react dangerously when mixed with water. The U.S. Department of Transportation (DOT) regulates transport of lithium-ion batteries under the DOT's Hazardous Materials Regulations (HMR) (49 CFR Parts 171-180). The HMR applies to any material DOT determines is capable of posing an unreasonable risk to health, safety, and property when transported in commerce. Lithium-ion batteries must conform to all applicable HMR requirements when offered for transportation or transported by air, highway, rail, or water. Additionally, carbon (as graphite) is flammable and could pose a fire hazard. Fire protection is achieved through project design features, such as monitoring, diagnostics and a fire suppression system. The project would be required to comply with state laws and county ordinance restrictions, which regulate and control hazardous materials handled on site. The project will also be required to comply with Imperial County Fire Department Fire Prevention Bureau CUP Conditions of Approval for solar project and BESS systems as identified in their February 26, 2024, correspondence for the project and summarized in Section XV Public Services ai) of this Initial Study.

Further, the proposed project would be required to comply with all applicable rules and regulations involving hazardous materials, including the State of California CCR Title 23 Health and Safety Regulations, the California Division of Occupational Safety and Health (Cal/OSHA) requirements, the Hazardous Waste Control Act, the California Accidental Release Prevention (CalARP) Program, and the California Health and Safety Code. Compliance with these measures would reduce any potential risk or impact associated with the transport, use, or disposal of hazardous materials. This impact is considered less than significant.

- b) **Less than Significant Impact.** According to the Phase I ESA prepared for the project, no recognized environmental conditions (RECs), historical recognized environmental conditions, *de minimis* conditions, or environmental concerns were found in connection with the project site.

As described in Response IX. a) above, the proposed solar and BESS facility would require the storage of hazardous materials; however, hazardous substances would be stored in transportable containment trailers at locations within the construction staging area to minimize potential for accidental releases and/or spills. No other hazardous or potentially hazardous materials will be brought to the project site. Further, the proposed project would be required to comply with all applicable rules and regulations involving hazardous materials, including the State of California CCR Title 23 Health and Safety Regulations, Cal/OSHA requirements, the Hazardous Waste Control Act, the CalARP Program, and the California Health and Safety Code. Compliance with these measures would reduce any potential risk or impact associated with the release of hazardous materials into the environment.

The project applicant will coordinate with the Imperial County Fire Department on conditions of approval as part of the CUP to ensure the proposed project would not result in extreme hazards to the public, firefighters, and emergency responders. Conditions of approval would include project plans review and inspections, installation of a water supply capable of supplying the required fire flow, development of an Emergency Operation Plan, and compliance with applicable standards and requirements of the National Fire Protection Association, Occupational Safety and Health Administration, and California Fire Code. With adherence of applicable standards and requirements and conditions of approval as part of the CUP, a less than significant impact would occur.

- c) **No Impact.** The project site is not located within 0.25 mile of any existing or proposed schools. The nearest school is Grace Smith Elementary School located approximately 6.4 miles south of the project site. Therefore, the proposed project would not pose a risk to nearby schools and no impact would occur.
- d) **No Impact.** As part of the Phase I ESA prepared for the project, a database search was conducted on June 21, 2022, to obtain and review reasonably ascertainable records that would help identify RECs and HRECs in connection with the project site. Databases that were reviewed include the following:
- EPA's Federal National Priorities List
 - EPA's Comprehensive Environmental Response, Compensation, and Liability Information System (CERCLA) List
 - Federal CERCLA – No Further Remedial Action Planned (NFRAP)
 - Federal Resource Conservation Recovery Act (RCRA) List
 - Federal Emergency Response Notification System (ERNS) List
 - State and Tribal NPL List
 - State and Tribal equivalent CERCLA
 - State and Tribal Leaking Underground Storage Tank Sites
 - State and Tribal Underground and Aboveground Storage Tank Sites
 - Solid Waste Disposal/Landfill Facilities (SWF/LF)
 - Unmapped (Orphan) Sites

A review of the databases, along with additional government environmental record databases, identified no risk sites within the project site. Therefore, implementation of the proposed project would result in no impact related to the project site being located on a listed hazardous materials site pursuant to Government Code Section 65962.5.

- e) **No Impact.** The project site is not located within 2 miles of a public airport. The nearest airport is the Cliff Hatfield Memorial Airport located approximately 15 miles south of the project site. Therefore, implementation of the proposed project would not result in a safety hazard or excessive noise for people residing or working in the project area and no impact would occur.
- f) **No Impact.** The proposed project does not include any alteration to the existing public road network and would not involve blocking or restricting any access routes. The proposed access road would be designed in accordance with fire department standards. Therefore, the proposed project would not interfere with an adopted emergency response plan or emergency evacuation plan. No impact is identified for this issue area.
- g) **No Impact.** The project site is located in the unincorporated area of Imperial County and north of the City of Niland. According to the Seismic and Public Safety Element of the General Plan, the potential for a major fire in the unincorporated areas of the County is generally low (County of Imperial 1997). Based on a review of the California Department of Forestry and Fire Protection's fire hazard severity zone map, the project site is not located within a fire hazard severity zone. The nearest fire hazard severity zone is classified as moderate and located approximately 30 miles northwest to the project site (California Department of Forestry and Fire Protection 2022). The proposed project would not introduce features that directly or indirectly increase the risk of wildfire on the project site. No impact is identified for this issue area.

X. Hydrology and Water Quality

Environmental Issue Area:	Potentially Significant Impact	Less than Significant with Mitigation Incorporated	Less Than Significant Impact	No Impact
<i>Would the project:</i>				
a) Violate any water quality standards or waste discharge requirements or otherwise substantially degrade surface or ground water quality?	<input type="checkbox"/>	<input type="checkbox"/>	<input checked="" type="checkbox"/>	<input type="checkbox"/>
b) Substantially decrease groundwater supplies or interfere substantially with groundwater recharge such that the project may impede sustainable groundwater management of the basin?	<input type="checkbox"/>	<input type="checkbox"/>	<input checked="" type="checkbox"/>	<input type="checkbox"/>
c) Substantially alter the existing drainage pattern of the site or area, including through the alteration of the course of a stream or river or through the addition of impervious surfaces, in a manner which would:				
i. result in substantial erosion or siltation on- or off-site;	<input type="checkbox"/>	<input type="checkbox"/>	<input checked="" type="checkbox"/>	<input type="checkbox"/>
ii. substantially increase the rate or amount of surface runoff in a manner which would result in flooding on- or offsite;	<input type="checkbox"/>	<input type="checkbox"/>	<input checked="" type="checkbox"/>	<input type="checkbox"/>
iii. create or contribute runoff water which would exceed the capacity of existing or planned stormwater drainage systems or provide substantial additional sources of polluted runoff; or	<input type="checkbox"/>	<input type="checkbox"/>	<input checked="" type="checkbox"/>	<input type="checkbox"/>
iv. impede or redirect flood flows?	<input type="checkbox"/>	<input type="checkbox"/>	<input checked="" type="checkbox"/>	<input type="checkbox"/>
d) In flood hazard, tsunami, or seiche zones, risk release of pollutants due to project inundation?	<input type="checkbox"/>	<input type="checkbox"/>	<input checked="" type="checkbox"/>	<input type="checkbox"/>
e) Conflict with or obstruct implementation of a water quality control plan or sustainable groundwater management plan?	<input type="checkbox"/>	<input type="checkbox"/>	<input checked="" type="checkbox"/>	<input type="checkbox"/>

Impact Analysis

- a) **Less than Significant Impact.** The proposed project would require construction activities that would disturb soils. Pollutants typical of construction work, such as sediments, trash, petroleum products, concrete waste, sanitary waste, and chemicals could significantly affect water quality. However, construction activities are regulated under the NPDES General Permit for Discharges of Storm Water Runoff Associated with Construction Activity

(General Construction Permit) which covers stormwater runoff requirements for projects where the total amount of ground disturbance during construction exceeds one acre. The proposed project would be required to comply with the General Construction Permit because ground disturbance would exceed one acre. Coverage under a General Construction Permit requires the preparation of a SWPPP and submittal of a NOI to comply with the General Construction Permit. The SWPPP will be implemented such that stormwater discharges would not adversely impact human health or the environment, nor contribute to any exceedances of any applicable water quality standards contained in the Colorado River Basin Plan. This impact is considered less than significant.

- b) **Less than Significant Impact.** The project site is located within the East Salton Sea Groundwater Basin (Basin). During construction, water will be needed for dust control and soil conditioning during installation of PV panels, battery storage units, and related infrastructure. The construction water demand is approximately 145 af. Construction is anticipated to require 12 months to complete, thus, the monthly water demand during that period would average approximately 12 af. During the operational phase of the project, water will be needed for routine maintenance activities, which primarily consists of PV panel washing to maintain generation efficiency. The operational water demand is anticipated to be 12.5 af/y for panel washing and other maintenance activities. The operational demand will exist for the life of the project, which is anticipated to be 25 to 30 years.

The construction water demand is short-term and temporary and is less than the annual recharge to the Basin of 200 acre-feet per year. Based on the analysis in the *Water Supply Assessment* prepared for the project (Appendix K of this Initial Study), there will be sufficient water available for existing water uses in the Basin, along with the project's water demand. As a result, the proposed project would not impede groundwater recharge and a less than significant impact would occur.

- ci) **Less than Significant Impact.** As discussed in Response X. a) above, the construction of the proposed project would result in ground disturbing activities in an area greater than one acre. Therefore, SWPPP will be developed that implements BMPs that sufficiently avoid any onsite or offsite erosion and runoff from areas proposed for ground disturbance. This is considered a less than significant impact.
- cii) **Less than Significant Impact.** The proposed project would not involve the construction of substantial impervious surfaces that would increase the rate of run-off. Construction activities would be localized to the project site boundary and access road, and the surrounding pervious surface would remain similar to pre-project conditions. Water will continue to percolate through the ground, as a majority of the surfaces on the project site will remain pervious. In this context, the proposed project would not result in substantial increases in run-off. This is considered a less than significant impact.
- ciii) **Less than Significant Impact.** Water will continue to percolate through the ground, as a majority of the surfaces on the project site will remain pervious. The proposed project would not create or contribute runoff water which would exceed the capacity of existing or planned stormwater drainage systems or provide substantial additional sources of polluted runoff. This is considered a less than significant impact.
- civ) **Less than Significant Impact.** According to the Federal Emergency Management Agency (FEMA) Flood Insurance Rate Map (Map Number 06025C0425C), the project site is located within Zone X with dry wash beds originating at the Coachella Canal siphons and crossing the site as Flood Zone A (Figure 7). Flood Zone X is an area determined to be outside of the 0.2 percent annual chance of a flood. Flood Zone A is an area within a special flood hazard area subject to inundation by the 1 percent annual chance (100-year) of flood.

The proposed project would be designed to comply with the *County of Imperial Engineering Design Guidelines Manual for the Preparation and Checking of Street Improvements, Drainage and Grading Plans within Imperial County* (2008). The proposed retention basin(s) would be sized to capture storm water runoff as if none of it would penetrate into the ground.

The County requirement to provide 3 inches of detention per tributary acre would be met and detained runoff would infiltrate the underlying soil.

Any improvements within Flood Zone A would be designed to comply with the County of Imperial Flood Zone Ordinances and guidelines. Section 91604.00 states that “A Development Permit shall be obtained before construction or development begins within any area of special flood hazards or areas of mudslide (i.e., mudflow) established in Section 91603.01.”

Based on the proposed drainage described above, and the project’s mandatory compliance with regulations regarding hydrology and drainage at the project site, implementation of the proposed project would not have a substantial impact on the hydrology of the surrounding area. Peak flow runoff from the project site would be directed to and infiltrated in designated retention basins and/or percolate into the ground, such that there would be no increase in on-site or off-site flooding potential. Therefore, on- and off-site drainage and flooding impacts would be less than significant.

d) Less than Significant Impact. The project site is located over 100 miles inland from the Pacific Ocean. Therefore, the proposed project is not located in an area at risk of tsunamis.

According to the Seismic and Public Safety Element of the General Plan, the most likely location for a significant seiche to occur is the Salton Sea, which is located approximately 3.4 miles west of the project site. While there have been a number of seismic events since the formation of the Salton Sea, no significant seiches have occurred to date. A seiche could occur, however, in the Salton Sea under the appropriate seismic conditions. The Salton Sea is proximal to the San Andreas and San Jacinto faults and would be subject to significant seismic ground shaking that could generate a seiche (County of Imperial 1997). The likelihood of seismic activity producing waves large enough to affect the project site is low and therefore, the risk of release of pollutants attributable to inundation is considered low based on no documented history of seiche-induced flooding of the project site. No substantial damage is expected from seiches on the project site, and implementation of the project would not increase the inherent risk of seiches on the project site.

The project site contains two dry wash beds in Flood Zone A (Figure 7), crossing the site that originate from the Coachella Canal (Appendix G of this Initial Study). However, the proposed project would be required to prepare a SWPPP that implements BMPs that would minimize potential impacts related to the risk of releasing pollutants due to project inundation. Therefore, the impacts would be considered less than significant.

e) Less than Significant Impact. As discussed above, the proposed project would be compliant with all local, state, and federal regulations, including compliance with the NPDES permits with the implementation of BMPs. Compliance with the referenced regulations would reduce any potential impact associated with a water quality control plan to a less than significant impact.

Figure 7. Flood Zone Map

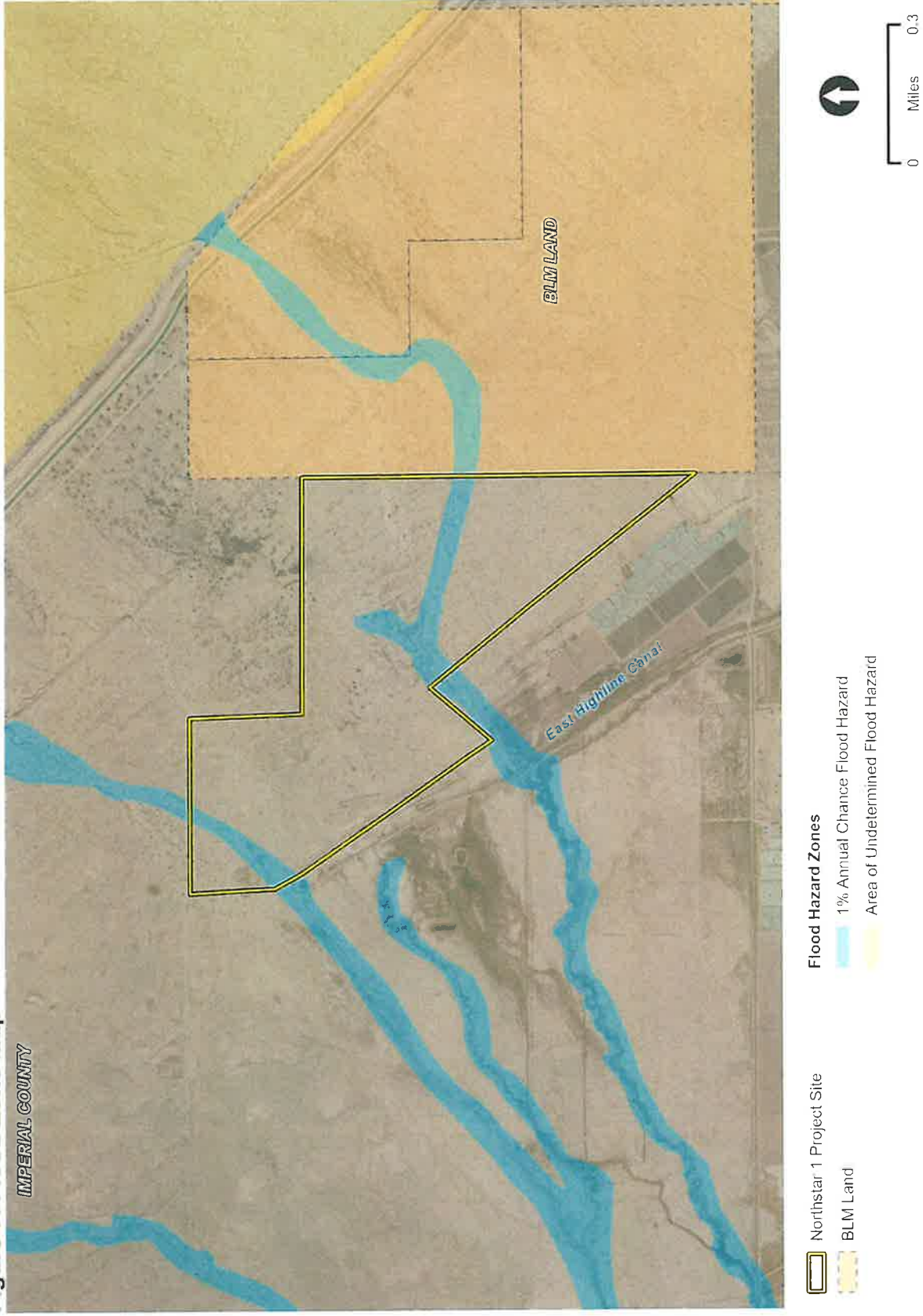



This page is intentionally blank.

XI. Land Use and Planning

Environmental Issue Area:	Potentially Significant Impact	Less than Significant with Mitigation Incorporated	Less Than Significant Impact	No Impact
Would the project:				
a) Physically divide an established community?	<input type="checkbox"/>	<input type="checkbox"/>	<input type="checkbox"/>	<input checked="" type="checkbox"/>
b) Cause a significant environmental impact due to a conflict with any land use plan, policy, or regulation adopted for the purpose of avoiding or mitigating an environmental effect?	<input type="checkbox"/>	<input type="checkbox"/>	<input checked="" type="checkbox"/>	<input type="checkbox"/>

Impact Analysis

- a) **No Impact.** The project site is located on vacant desert land approximately seven miles north of the unincorporated community of Niland. The project site is surrounded by vacant desert land to the west, north, and east and agricultural land to the south. There are no established communities located within or in the vicinity of the project site. The nearest residence is one single-family residence located approximately 450 feet west from the western boundary of the project site. The proposed project does not involve project components that could physically divide an established community. Therefore, implementation of the proposed project would not divide an established community and no impact would occur.
- b) **Less than Significant Impact.** The project’s consistency with applicable land use plans, policies, and regulations is evaluated below.

County of Imperial General Plan. The County adopted the Renewable Energy (RE) and Transmission Element, which includes a RE Zone (RE Overlay Map). The County Land Use Ordinance, Division 17, includes the RE Overlay Zone, which authorizes the development and operation of renewable energy projects with an approved CUP. The RE Overlay Zone is concentrated in areas determined to be the most suitable for the development of renewable energy facilities while minimizing the impact on other established uses. CUP applications proposed for specific renewable energy projects not located in the RE Overlay Zone would not be allowed without an amendment to the RE Overlay Zone.

Of the two parcels that comprise the project site, APN 003-110-005 is within the County’s RE Overlay Zone; however, APN 003-110-007 is outside of the RE Overlay Zone. Without an amendment to the RE Overlay Zone, the proposed project would not be allowed and would conflict with the RE and Transmission Element of the General Plan. However, the applicant is requesting a General Plan amendment and Zone Change to include/classify APN 003-110-007 into the RE Overlay Zone.

As stated in the RE and Transmission Element:

An amendment to the overlay zone would only be approved by the County Board of Supervisors if a future RE project met one of the following two conditions:

- **“Adjacent to the Existing RE Overlay Zone”:** An amendment may be made to allow for development of a future RE project located adjacent to the existing RE Overlay Zone if the project:
 - Is not located in a sensitive area



- Would not result in any significant impacts.
- **“Island Overlay”**: An amendment may be made to allow for development of a future RE project that is not located adjacent to the existing RE Overlay Zone if the project:
 - Is located adjacent (sharing a common boundary) to an existing transmission source
 - Consists of the expansion of an existing RE operation
 - Would not result in any significant environmental impacts (County of Imperial 2016).

As previously mentioned above, of the two project parcels, APN 003-110-005 is within the County’s RE Overlay Zone. As such, the project site located adjacent to the existing RE Overlay Zone. Therefore, the proposed project will need to meet the criteria identified for the “Adjacent to the Existing RE Overlay Zone” to obtain approval of an amendment to the RE Overlay Zone. Table 13 provides an analysis of the project’s consistency with the “Adjacent to the Existing RE Overlay Zone” criteria. As shown in Table 13, the proposed project would be consistent with the “Adjacent to the Existing RE Overlay Zone” criteria because the project is not located in a sensitive area and would not result in significant environmental impacts.

The General Plan Amendment and Zone Change requests submitted by the project applicant are subject to approval by the County Board of Supervisors. If approved, the project applicant will be able to request for approval of a CUP to allow the construction and operation of the proposed solar facility and BESS, and the proposed project would be consistent with the RE and Transmission Element of the General Plan.

Table 13. Project Consistency with “Adjacent to the Existing RE Overlay Zone” Criteria

Criteria	Criteria Met?
Is not located in a sensitive area?	The project site is not located on land designated as Prime Farmland, Unique Farmland, or Farmland of Statewide Importance. The project site is also not in a recognized species corridor or habitat linkage.
Would not result in any significant impacts?	As detailed in Sections I through XXI of this Initial Study, no unavoidable or unmitigable significant impacts were identified. Where significant impacts have been identified, mitigation measures are proposed, that when implemented, would reduce the impact level to less than significant. Therefore, the proposed project would not result in a residual significant impact.

Source: County of Imperial 2016

County of Imperial Land Use Ordinance. Implementation of the project would require the approval of a CUP by the County to allow for the construction and operation of the proposed solar energy facility with an integrated battery storage system. The project parcels are currently zoned as S-2 and S-2-RE. Pursuant to Title 9, Division 5, Chapter 19, the following uses are permitted in the S-2 zone subject to approval of a CUP from Imperial County:

i) Major facilities relating to the generation and transmission of electrical energy, provided such facilities are not, under state or federal law, to be approved exclusively by an agency, or agencies of the state and/or federal governments, and provided that such facilities shall be approved subsequent to coordination and review with the Imperial Irrigation District for electrical matters. Such uses shall include, but not be limited to, the following:

- *Electrical generation plants*
- *Facilities for the transmission of electrical energy (100-200 kV)*

- *Electrical substations in an electrical transmission system (500 kV/230kV/161kV)*

The CUP request submitted by the project applicant is subject to approval by the County Board of Supervisors. If the CUP is approved, the proposed project would not conflict with the County's zoning ordinance and no impact would occur.

XII. Mineral Resources

Environmental Issue Area:	Potentially Significant Impact	Less than Significant with Mitigation Incorporated	Less Than Significant Impact	No Impact
Would the project:				
a) Result in the loss of availability of a known mineral resource that would be of value to the region and the residents of the state?	<input type="checkbox"/>	<input type="checkbox"/>	<input type="checkbox"/>	<input checked="" type="checkbox"/>
b) Result in the loss of availability of a locally-important mineral resource recovery site delineated on a local general plan, specific plan, or other land use plan?	<input type="checkbox"/>	<input type="checkbox"/>	<input type="checkbox"/>	<input checked="" type="checkbox"/>

Impact Analysis

- a) **No Impact.** Construction of the proposed project would not result in any impacts to known mineral resources or mineral resource recovery sites. The nearest active mines for mineral resources to the project site are construction sand and gravel (California DOC 2016). The project does not propose any extraction and thus loss of availability of these mineral resources. Additionally, the proposed project would not preclude future mineral resource exploration throughout the project site. No impact would occur.
- b) **No Impact.** As noted in Response XII. a), implementation of the proposed project would not result in any impacts to known mineral resources or mineral resource recovery sites. Additionally, the proposed project would not preclude future mineral resource exploration throughout the project site. No impact would occur.

XIII. Noise

Environmental Issue Area:	Potentially Significant Impact	Less than Significant with Mitigation Incorporated	Less Than Significant Impact	No Impact
Would the project result in:				
a) Generation of a substantial temporary or permanent increase in ambient noise levels in the vicinity of the project in excess of standards established in the local general plan or noise ordinance, or applicable standards of other agencies?	<input type="checkbox"/>	<input type="checkbox"/>	<input checked="" type="checkbox"/>	<input type="checkbox"/>



XIII. Noise

Environmental Issue Area:	Potentially Significant Impact	Less than Significant with Mitigation Incorporated	Less Than Significant Impact	No Impact
b) Generation of excessive groundborne vibration or groundborne noise levels?	<input type="checkbox"/>	<input type="checkbox"/>	<input checked="" type="checkbox"/>	<input type="checkbox"/>
c) For a project located within the vicinity of a private airstrip or an airport land use plan or, where such a plan has not been adopted, within two miles of a public airport or public use airport, would the project expose people residing or working in the project area to excessive noise levels?	<input type="checkbox"/>	<input type="checkbox"/>	<input type="checkbox"/>	<input checked="" type="checkbox"/>

Impact Analysis

The following information is summarized from the *Noise Impact Assessment* prepared by ECORP. This report is provided as Appendix I of this Initial Study.

- a) **Less than Significant Impact.** Predicted construction noise levels were calculated using the Federal Highway Administration’s (FHWA) Roadway Construction Noise Model (2006).

The American National Standards Institute (ANSI) Standard 12.9-2013/Part 3 divides land uses into six distinct categories based on the ambient noise environment. The majority of the project area would be considered ambient noise Category 5 (Quiet Residential Areas) or 6 (Very Quiet Sparse Suburban or Rural Residential Areas). Category 5 areas are isolated, far from significant sources of sound and are estimated to have a typical day-night average (L_{dn}) of 47 decibels A-weighted (dBA), a daytime equivalent noise level (L_{eq}) of 45 dBA, and a nighttime L_{eq} 39 dBA. Category 6 has few if any nearby sources of sound and is estimated to have a typical L_{dn} of 42 dBA, a daytime L_{eq} of 40 dBA, and a nighttime L_{eq} of 34 dBA.

To estimate the worst-case operational noise levels that may occur at the nearest noise-sensitive receptor, on-site operational noise levels were calculated using the SoundPLAN 3D Noise Model, coupled with noise measurements that were measured by ECORP at an existing solar energy generation facility. Specifically, ECORP conducted a 30-minute reference noise measurement within the IVC solar generation facility in Imperial County, which satisfies the American National Standards Institute for general environmental noise measurement instrumentation. This reference measurement identified an ambient noise environment of 47.1 dBA at the existing solar energy facility. Therefore, a noise level of 47.1 dBA was employed as the reference noise level in the SoundPLAN 3D Noise Model to determine noise-level propagation associated with project operations.

Construction

Temporary construction noise associated with the project would primarily be from the operation of off-road equipment for onsite construction activities as well as construction vehicle traffic on area roadways. Noise generated by construction equipment, including earth movers, pile drivers, and portable generators, can reach high levels. Other primary sources of acoustical disturbance would be random incidents, which would last less than one minute (such as dropping large pieces of equipment or the hydraulic movement of machinery lifts). During construction, exterior noise levels could affect sensitive land uses in the vicinity of the construction site.

The nearest existing noise-sensitive land use to the project site is a single-family residence located approximately 450 feet from the western project boundary. Pursuant to the County's General Plan Noise Element, construction equipment operation shall be limited to the hours of 7:00 a.m. to 7:00 p.m., Monday through Friday, and 9:00 a.m. to 5:00 p.m. on Saturdays. No commercial construction operations are permitted on Sundays or holidays. Construction noise, from a single piece of equipment or a combination of equipment, shall not exceed 75 dB L_{eq} , when averaged over an eight-hour period, and measured at the nearest sensitive receptor.

The anticipated short-term construction noise levels generated for the construction equipment for the proposed project is presented in Table 14. As shown in Table 14, no individual or cumulative pieces of construction equipment would exceed the 75 dBA County construction noise standard during any phase of construction at the nearby noise-sensitive receptor. All calculated noise levels during construction would fall within the normally acceptable range of the guidance set forth in the County of Imperial General Plan Noise Element. Therefore, the project's construction noise impacts would be less than significant.

Table 14. Construction Average (dBA) Noise Levels at Nearest Receptor

Equipment	Estimated Exterior Construction Noise Level at Existing Residence	Construction Noise Standards (dBA L_{eq})	Exceed Standards?
Site Preparation			
Off-Highway Truck	53.4	75	No
Rubber Tired Dozers (2)	58.6 (each)	75	No
Tractors/Loaders/Backhoes (2)	60.9 (each)	75	No
Combined Site Preparation Equipment	66.2	75	No
Grading			
Excavators (4)	57.6 (each)	75	No
Graders (3)	61.9 (each)	75	No
Rubber Tired Dozers (2)	58.6 (each)	75	No
Scrapers (2)	60.5 (each)	75	No
Tractors/Loaders/Backhoes (2)	60.9 (each)	75	No
Combined Grading Equipment	72.0	75	No
Facility Construction			
Crane	53.5	75	No
Off-Highway Trucks (4)	53.4 (each)	75	No
Paver	55.1	75	No
Paving Equipment (2)	63.4 (each)	75	No
Plate Compactors (4)	57.2 (each)	75	No
Rollers (2)	53.9 (each)	75	No
Rough Terrain Forklifts (4)	60.3 (each)	75	No
Tractors/Loaders/Backhoes (4)	60.9 (each)	75	No
Trenchers (2)	58.3 (each)	75	No
Welder	50.9	75	No

Combined Construction, Trenching, and Paving	71.8	75	No
---	-------------	-----------	-----------

Source: Appendix I of this Initial Study

Operation

The main stationary operational noise associated with the project would be from the proposed transformers, inverters, substation, and transmission lines. As previously stated, the nearest sensitive receptor to the project site is a single-family residence located approximately 450 feet from the western boundary of the project.

To estimate the worst-case operational noise levels that may occur at the nearest noise-sensitive receptor, on-site operational noise levels were calculated using the SoundPLAN 3D Noise Model, coupled with noise measurements that were measured by ECORP at an existing solar energy generation facility. Specifically, ECORP conducted a 30-minute reference noise measurement within the IVC solar generation facility in Imperial County, which satisfies the American National Standards Institute for general environmental noise measurement instrumentation. This reference measurement identified an ambient noise environment of 47.1 dBA at the existing solar energy facility. Therefore, a noise level of 47.1 dBA was employed as the reference noise level in the SoundPLAN 3D Noise Model to determine noise-level propagation associated with project operations.

Section 90702.00 of the Noise Ordinance sets a sound level limit of 50 dBA Leq for daytime hours of 7 a.m. to 10 p.m. and 45 dBA Leq during the noise sensitive nighttime hours of 10 p.m. to 7 a.m. for residential noise sensitive land uses. The proposed project is expected to operate during both daytime and nighttime hours and therefore the most restrictive and conservative approach is to apply the 45 dBA Leq nighttime standard at the property lines.

Table 15 shows project noise levels at the nearest sensitive receptor in the project vicinity. As shown in Table 15, project operational noise would not exceed County daytime or nighttime standards. Therefore, operational noise impacts would be less than significant.

Table 15. Modeled Operational Noise Levels at Nearest Receptor

Location	Modeled Operational Noise Attributed to Project (Leq dBA)	County Daytime Standard (Leq dB)	County Nighttime Standard (Leq dB)	Exceed Standard?
Single-Family Residence (450 feet from west boundary)	38.5	50.0	45.0	No

Source: Appendix I of this Initial Study

Transportation Noise

Project operations would result in minimal additional traffic on adjacent roadways. The only visitors to the site would be that of repair or maintenance workers, whose presence at the site would be required infrequently and inconsistently. According to the California Department of Transportation (Caltrans) *Technical Noise Supplement to the Traffic Noise Analysis Protocol* (2013), doubling of traffic on a roadway is required to result in an increase of 3 dB. The project would not result in a doubling of traffic on vicinity roadways, and therefore its contribution to existing traffic noise would not be perceptible. Therefore, the project’s transportation-related noise impact is considered less than significant.

- b) **Less than Significant Impact.** Project construction would have the potential to result in temporary groundborne vibration, depending on the specific construction equipment used and the operations involved. Construction-related ground vibration is normally associated with impact

equipment such as pile drivers, jackhammers, and the operation of some heavy-duty construction equipment, such as dozers and trucks. Pile drivers would be necessary during project construction. Vibration decreases rapidly with distance and it is acknowledged that construction activities would occur throughout the project site and would not be concentrated at the point closest to sensitive receptors. Groundborne vibration levels associated with typical construction equipment at 25 feet distant are summarized in Table 16.

Table 16. Representative Vibration Source Levels for Construction Equipment

Equipment Type	Peak Particle Velocity at 25 Feet (Inches per Second)
Large Bulldozer	0.089
Pile Driver	0.170
Loaded Trucks	0.076
Hoe Ram	0.089
Jackhammer	0.035
Small Bulldozer/Tractor	0.003
Vibratory Roller	0.210

Source: Appendix I of this Initial Study

Imperial County does not regulate vibrations associated with construction. For comparison purposes, the Caltrans recommended standard of 0.2 inch per second peak particle velocity (PPV) with respect to the prevention of structural damage is used as a threshold. Consistent with FTA recommendations for calculating construction vibration, construction vibration was measured from the center of the project site (Appendix I of this Initial Study). The nearest structure of concern to the project site, with regard to groundborne vibrations, are solar panels located approximately 350 south of the project site. Table 17 shows the expected project-related vibration levels at a distance of 350 feet.

Table 17. Construction Vibration Levels at 350 Feet

Large Bulldozer, Caisson Drilling & Hoe Ram	Loaded Trucks	Jackhammer	Pile Driver	Vibratory Roller	Peak Vibration	Threshold	Exceed Threshold?
0.002	0.002	0.001	0.003	0.004	0.004	0.2	No

Source: Appendix I of this Initial Study

Based on the representative vibration levels presented for various construction equipment types in Table 17 and the construction vibration assessment methodology published by the FTA, it is possible to estimate the potential project construction vibration levels. From a distance of 350 feet, vibration as a result of construction activities would not exceed 0.2 PPV at the nearest structure. Therefore, project construction would not exceed the recommended threshold and vibration impacts would be less than significant.

- c) **No Impact.** The project site is not located within two miles of a public airport. The nearest airport is the Cliff Hatfield Memorial Airport, located approximately 15 miles south of the project site. Therefore, implementation of the proposed project would not expose people residing or working in the project area to excessive noise levels and no impact would occur.

XIV. Population and Housing

Environmental Issue Area:	Potentially Significant Impact	Less than Significant with Mitigation Incorporated	Less Than Significant Impact	No Impact
Would the project:				
a) Induce substantial unplanned population growth in an area, either directly (e.g., by proposing new homes and businesses) or indirectly (e.g., through extension of roads or other infrastructure)?	<input type="checkbox"/>	<input type="checkbox"/>	<input type="checkbox"/>	<input checked="" type="checkbox"/>
b) Displace substantial numbers of existing people or housing, necessitating the construction of replacement housing elsewhere?	<input type="checkbox"/>	<input type="checkbox"/>	<input type="checkbox"/>	<input checked="" type="checkbox"/>

Impact Analysis

- a) **No Impact.** The proposed project would not induce unplanned population growth. The proposed project involves the construction and operation of a solar and BESS facility on a vacant parcel. No development of new roads or infrastructure is proposed that would introduce new populations to the project site. The proposed access road would be used only to access the proposed facility. No impact would occur.
- b) **No Impact.** No residential units are on the project site that would require relocation. Therefore, the proposed project would not displace substantial numbers of existing people or housing necessitating the construction of replacement housing elsewhere. No impact would occur.

XV. Public Services

Environmental Issue Area:	Potentially Significant Impact	Less than Significant with Mitigation Incorporated	Less Than Significant Impact	No Impact
a) Would the project result in substantial adverse physical impacts associated with the provision of new or physically altered governmental facilities, need for new or physically altered governmental facilities, the construction of which could cause significant environmental impacts, in order to maintain acceptable service ratios, response times or other performance objectives for any of the public services:				
i. Fire Protection?	<input type="checkbox"/>	<input type="checkbox"/>	<input type="checkbox"/>	<input checked="" type="checkbox"/>
ii. Police Protection?	<input type="checkbox"/>	<input type="checkbox"/>	<input type="checkbox"/>	<input checked="" type="checkbox"/>
iii. Schools?	<input type="checkbox"/>	<input type="checkbox"/>	<input type="checkbox"/>	<input checked="" type="checkbox"/>

XV. Public Services

Environmental Issue Area:	Potentially Significant Impact	Less than Significant with Mitigation Incorporated	Less Than Significant Impact	No Impact
iv. Parks?	<input type="checkbox"/>	<input type="checkbox"/>	<input type="checkbox"/>	<input checked="" type="checkbox"/>
v. Other public facilities?	<input type="checkbox"/>	<input type="checkbox"/>	<input type="checkbox"/>	<input checked="" type="checkbox"/>

Impact Analysis

- ai) **No Impact.** Fire protection and emergency medical services in the project area are provided by the Imperial County Fire Department. The nearest station to the project site is Niland Fire District Station 2, located approximately 6.5 miles south of the site.

CUP Conditions of Approval for Imperial County Fire Department Fire Prevention Bureau:

The project applicant will be required to comply with Imperial County Fire Department Fire Prevention Bureau CUP Conditions of Approval for solar project and BESS systems as identified in their February 26, 2024, correspondence for the project. These CUP Conditions of Approval include the following:

Solar Requirements

- Approved all-weather access roads for fire protection vehicles shall be provided throughout the project, conforming with the California Fire Code Chapter 5, section 503. Access roadways shall be all-weather surface (suitable for use by fire apparatus) right-of-way not less than 20 feet in width.
- Access roadways shall provide intersecting roadways to allow unobstructed movement of fire apparatus throughout the project site. Solar array layout shall meet Imperial County Fire Department layout requirements.
- Additional access shall be provided to the project site in accordance with the California Fire Code Chapter 5, section 503.
- KNOX Box and/or Locks will be required for all access gates as determined by Imperial County Fire Department.
- Solar array fields shall be clear of all vegetation.
- A pre-incident plan shall be developed and approved by the Imperial County Fire/OES Department in a format and using a platform determined by ICFD.

Battery Energy Storage Systems

- An approved water supply capable of supplying the required fire flow determined by appendix B in the California Fire Code Shall be installed and maintained. (Minimum fire flow of 1500 GPM for 2 hours) Private fire service mains and appurtenance shall be installed in accordance with NFPA 20, 22, 24
- An approved automatic fire suppression system shall be installed on all required structures as per the California Fire Code Chapter 12 and NFPA 855. All fire suppression systems will be installed and maintained to the current adapted fire code and regulations.
- An approved automatic fire detection system shall be installed on all required structures as per the California Fire Code Chapter 12 and NFPA 855. All fire detection systems will be installed and maintained to the current adapted fire code and regulations.

- Owners and operators of ESS must develop and Emergency Operation Plan in conjunction with local fire service personnel, the AHJ, and hold a comprehensive understanding of the hazards associated with lithium-ion battery technology. Lithium-ion battery ESS's must incorporate adequate explosion prevention protection in accordance with NFPA 855 and/or California Fire Code Chapter 12.
- Signage shall be provided in accordance California Fire Code Chapter 12 Compliance with all required sections of the fire code.
- Applicant shall provide product containment areas(s) for both product and water run-off in case of fire applications and retained for removal.
- An emergency response/action plan shall be prepared and approved by the Imperial County Fire/OES Department.
- A Hazardous Waste Material Plan shall be submitted to Certified Unified Program Agency (CUPA) for their review and approval.
- All hazardous material and waste shall be handled, stored, and disposed as per the approved Hazardous Waste Materials Plan. All spills shall be documented and reported to Imperial County Fire Department and CUPA as required by the Hazardous Waste Material Plan

The project site would continue to be adequately supported by the existing fire protection services since the construction and operation of the project would not induce growth in the project area and the fire risk would not create the need for new or physically altered fire protection facilities. Operation and maintenance would not affect the ability of fire personnel to respond to fires. Based on these considerations, the proposed project would not result in a need for fire facility expansion and no impact is identified.

- aii) **No Impact.** Police protection services in the project area is provided by the Imperial County Sheriff's Department. The project site is approximately 6.3 miles northwest of the Imperial County Sheriff's Office Niland Station. The City of Niland is a contract city for the Imperial County Sheriff's Office; however, the project site is not under the jurisdictional responsibility of the Niland Station. The nearest station for a response to the project site is the Calipatria Station, which is approximately 15 miles south of the project site.

The proposed project would not require police services during construction or operation and maintenance beyond routine patrols and response. Construction and operation of the proposed project would not induce growth in the project area that would result in the permanent, and increased need of police protection services. No impact would occur.

- aiii) **No Impact.** The proposed project does not include the development of residential land uses that would result in an increase in population or student generation. Construction is estimated to take approximately 12 months. The number of construction workers is not expected to require a substantial number of workers. Construction of the proposed project would not result in an increase in student population within the Imperial County's School District since it is anticipated that construction workers would commute in during construction operations. Furthermore, no full-time employees are required to operate the project. It is anticipated that maintenance of the project will be minimal to perform periodic visual inspections for security, maintenance, and system monitoring. The proposed project would not result in an increase in student population within the Imperial County's School District. Therefore, the proposed project would have no impact on Imperial County schools.

- aiv) **No Impact.** Construction is estimated to take approximately 12 months. The number of construction workers is not expected to require a substantial number of workers. Furthermore, no full-time employees are required to operate the project. It is anticipated that maintenance of the project will be minimal to perform periodic visual inspections for security, maintenance, and system monitoring. Substantial permanent increases in population that would adversely affect local parks is not anticipated. Therefore, the proposed project would have no impact on parks.

- av) **No Impact.** Construction is estimated to take approximately 12 months. The number of construction workers is not expected to require a substantial number of workers. Furthermore, no full-time employees are required to operate the project. It is anticipated that maintenance of the project will be minimal to perform periodic visual inspections for security, maintenance, and system monitoring. Substantial permanent increases in population that would adversely affect libraries and other public facilities (such as post offices) is not anticipated. Therefore, the proposed project would have no impact on other public facilities such as post offices and libraries.

XVI. Recreation

Environmental Issue Area:	Potentially Significant Impact	Less than Significant with Mitigation Incorporated	Less Than Significant Impact	No Impact
Would the project:				
a) Would the project increase the use of existing neighborhood and regional parks or other recreational facilities such that substantial physical deterioration of the facility would occur or be accelerated?	<input type="checkbox"/>	<input type="checkbox"/>	<input type="checkbox"/>	<input checked="" type="checkbox"/>
b) Does the project include recreational facilities or require the construction or expansion of recreational facilities, which might have an adverse physical effect on the environment?	<input type="checkbox"/>	<input type="checkbox"/>	<input type="checkbox"/>	<input checked="" type="checkbox"/>

Impact Analysis

- a) **No Impact.** The proposed project would not increase the use of existing neighborhood parks and regional parks or other recreational facilities. The proposed project would not induce new populations that would result in the substantial physical deterioration of recreational facilities. No impact would occur.
- b) **No Impact.** The proposed project would not include recreational facilities or require the construction or expansion of recreational facilities. The proposed project would not induce new populations that would require new recreational facilities. No impact would occur.



XVII. Transportation

Environmental Issue Area:	Potentially Significant Impact	Less than Significant with Mitigation Incorporated	Less Than Significant Impact	No Impact
Would the project:				
a) Conflict with a program plan, ordinance or policy addressing the circulation system, including transit, roadway, bicycle and pedestrian facilities?	<input type="checkbox"/>	<input type="checkbox"/>	<input checked="" type="checkbox"/>	<input type="checkbox"/>
b) Conflict with or be inconsistent with CEQA Guidelines section 15064.3, subdivision (b)?	<input type="checkbox"/>	<input type="checkbox"/>	<input checked="" type="checkbox"/>	<input type="checkbox"/>
c) Substantially increase hazards due to a geometric design feature (e.g., sharp curves or dangerous intersections) or incompatible uses (e.g., farm equipment)?	<input type="checkbox"/>	<input type="checkbox"/>	<input checked="" type="checkbox"/>	<input type="checkbox"/>
d) Result in inadequate emergency access?	<input type="checkbox"/>	<input type="checkbox"/>	<input checked="" type="checkbox"/>	<input type="checkbox"/>

Impact Analysis

The following information is summarized from the *Traffic, Parking, and Circulation Assessment* prepared by ECORP. This report is provided as Appendix I of this Initial Study.

- a) **Less than Significant Impact.** Highway 111 provides regional access to the project site and is located approximately 2.3 miles east of the project site. The adjacent roadway that would serve as the primary route for truck traffic to the project site would be via Coachella Canal Road between English and Frink Road. All construction traffic would utilize Coachella Canal Road to access the project site. Construction of the project would be temporary, and the traffic volumes generated by construction would be minor (160 worker commutes and 10 vendor trips daily to the project site). Once the proposed project is operational, there would be no increase in automobile trips to the area. While it is anticipated that the proposed project would require periodic maintenance, maintenance would be minimal requiring a negligible amount of traffic trips on an annual basis. Therefore, the potential for the proposed project to cause an increase in traffic to the existing traffic load and capacity of the street system would be negligible and this is considered a less than significant impact.

The proposed project would not include any project actions within roadway segments and is not in the vicinity of a public transit route, or bicycle or pedestrian facilities. Therefore, the proposed project would result in a less than significant impact related to a conflict with a program plan, ordinance or policy addressing transit, bicycle, and pedestrian facilities.

- b) **Less than Significant Impact.** Section 15064.3(b) of the CEQA Guidelines provides guidance on determining the significance of transportation impacts and focuses on the use of vehicle miles traveled (VMT), which is defined as the amount and distance of automobile travel associated with a project. Construction of the project would be temporary, and the traffic volumes generated by construction would be minor (160 worker commutes and 10 vendor trips daily to the project site). Given the nature of the project, after construction, there would be a nominal amount of vehicle trips generated by the project. Once the proposed project is operational, there would be no increase in automobile trips to the area. While it is anticipated that the proposed project would

require periodic maintenance, maintenance would be minimal requiring a negligible amount of traffic trips on an annual basis. In addition, operation of the project would not require any full-time employees on-site. Therefore, the proposed project would result in a less than significant VMT impact.

- c) **Less than Significant Impact.** The average daily trips during construction and operation would be minimal along the State Highways. The intersections at both SR-111 and English/Niland Road and SR-111 and Frink Road are railroad crossings. There is a potential for truck traffic approaching the project site along SR-111 to impede the flow of traffic while waiting at either crossing. However, these effects would be temporary and minor for the duration of construction, and no long-term effects on geometric design features on project vicinity roadways would occur that could result in an increase in hazards. This impact would be less than significant.
- d) **Less than Significant Impact.** There is a potential for truck traffic when approaching the project site along Coachella Canal Road. However, these effects would be temporary and minor, and no long-term effects on emergency access would occur that could result in an increase in hazards. Therefore, the proposed project would not result in inadequate emergency access and this impact is considered less than significant.

XVIII. Tribal Cultural Resources

Environmental Issue Area:	Potentially Significant Impact	Less than Significant with Mitigation Incorporated	Less Than Significant Impact	No Impact
<i>Would the project cause a substantial adverse change in the significance of a tribal cultural resource defined in Public Resources Code section 21074 as either a site, feature, place, cultural landscape that is geographically defined in terms of the size and scope of the landscape, sacred place, or object with cultural value to a California Native American tribe, and that is:</i>				
a) Listed or eligible for listing in the California Register of Historical Resources, or in a local register of historical resources as defined in Public Resources Code section 5020.1(k)?	<input type="checkbox"/>	<input checked="" type="checkbox"/>	<input type="checkbox"/>	<input type="checkbox"/>
b) A resource determined by the lead agency, in its discretion and supported by substantial evidence, to be significant pursuant to criteria set forth in subdivision (c) of Public Resources Code Section 5024.1. In applying the criteria set forth in subdivision (c) of Public Resources Code Section 5024.1, the lead agency shall consider the significance of the resource to a California Native American tribe?	<input type="checkbox"/>	<input checked="" type="checkbox"/>	<input type="checkbox"/>	<input type="checkbox"/>

Impact Analysis

- a-b) **Less than Significant Impact with Mitigation Incorporated.** Assembly Bill 52 was passed in 2014 and took effect July 1, 2015. It established a new category of environmental resources that must be considered under CEQA called tribal cultural resources (Public Resources Code 21074) and established a process for consulting with Native American tribes and groups regarding those resources. Assembly Bill 52 requires a lead agency to begin consultation with a California Native

American tribe that is traditionally and culturally affiliated with the geographic area of the proposed project.

In accordance with AB 52, Imperial County, as the CEQA lead agency, sent an AB 52/SB 18 consultation request letter to California Native American tribes that are traditionally and culturally affiliated with the project area on December 22, 2023. On February 1, 2024, the Agua Caliente Band of Cahuilla Indians responded via letter requesting consultation under SB 18. The project site is located within the Agua Caliente Band of Cahuilla Indians' Tribal Use Area. On February 2, 2024, the Viejas Band of Kumeyaay Indians (Viejas) responded via e-mail indicating that the project site has cultural significance or ties to Viejas and requested that a Native American monitor be on site during ground disturbing activities. Mitigation Measures CR-3 and TR-1 would ensure that potential impacts on tribal cultural resources do not rise to the level of significance.

Mitigation Measure:

TR-1 If previously unidentified tribal cultural resources are identified during construction activities, construction work within 100 feet of the find shall be halted and directed away from the discovery until a Secretary of the Interior qualified archaeologist and tribal representative assesses the significance of the resource. The archaeologist, in consultation with Imperial County and any interested Tribes, shall make the necessary plans for treatment of the find(s) and for the evaluation and mitigation of impacts if the finds are determined to be a tribal cultural resource as defined in PRC Section 21074.

XIX. Utilities and Service Systems

Environmental Issue Area:	Potentially Significant Impact	Less than Significant with Mitigation Incorporated	Less Than Significant Impact	No Impact
Would the project:				
a) Require or result in the relocation or construction of new or expanded water, wastewater treatment or storm water drainage, electric power, natural gas, or telecommunications facilities, the construction or relocation of which could cause significant environmental effects?	<input type="checkbox"/>	<input type="checkbox"/>	<input checked="" type="checkbox"/>	<input type="checkbox"/>
b) Have sufficient water supplies available to serve the project and reasonably foreseeable future development during normal, dry and multiple dry years?	<input type="checkbox"/>	<input type="checkbox"/>	<input checked="" type="checkbox"/>	<input type="checkbox"/>
c) Result in a determination by the wastewater treatment provider, which serves or may serve the project that it has adequate capacity to serve the project's projected demand in addition to the provider's existing commitments?	<input type="checkbox"/>	<input type="checkbox"/>	<input type="checkbox"/>	<input checked="" type="checkbox"/>
d) Generate solid waste in excess of State or local standards, or in excess of the capacity of local infrastructure, or otherwise impair the attainment of solid waste reduction goals?	<input type="checkbox"/>	<input type="checkbox"/>	<input checked="" type="checkbox"/>	<input type="checkbox"/>
e) Comply with federal, state, and local management and reduction statutes and regulations related to solid waste?	<input type="checkbox"/>	<input type="checkbox"/>	<input checked="" type="checkbox"/>	<input type="checkbox"/>

Impact Analysis

- a) **Less than Significant Impact.** The proposed project does not currently contain any public utilities or services. The proposed project would not require the construction of any water, wastewater, stormwater, or energy facilities to accommodate the demand of the project. During project construction, water will be needed for dust control and soil conditioning during installation of the photovoltaic panels, battery storage units, and related infrastructure. During the operational phase, water will be needed for routine maintenance activities, which will primarily consist of washing the photovoltaic panels to maintain generation efficiency. The project's water supply will be provided by a new onsite groundwater supply well to be drilled and installed as part of the project. Impacts associated with the project's groundwater well are inherent to the project's construction phase, and impacts have been evaluated throughout this Initial Study under the appropriate subject headings (air quality, biological resources, etc.).

The proposed project would not require the relocation, expansion, or construction of new storm drainage facilities because the proposed solar facility would not generate a significant increase

in the amount of impervious surfaces that would increase runoff during storm events and exceed the capacity of existing or planned stormwater drainage systems. Water from solar panel washing would continue to percolate through the ground, as a majority of the surfaces within the project site would remain pervious.

The wastewater generated during construction would be contained within portable toilet facilities and disposed of at an approved site. The minimal volume of wastewater generated during construction would not require the relocation expansion, or construction of wastewater treatment facilities.

Further, no habitable structures (e.g. housing or O&M buildings) are proposed on the project site. Therefore, the proposed project would not require or result in the relocation or construction of new or expanded electric power or natural gas.

- b) **Less than Significant Impact.** The following information is summarized from the Water Supply Assessment (WSA) prepared by ECORP. This report is provided as Appendix J of this Initial Study.

The project site is located within the East Salton Sea Groundwater Basin (Basin). The Basin is bounded on the northeast by the Chocolate Mountains and on the southwest by the San Andreas and Banning Mission Creek fault zones. The Basin has an area of approximately 196,000 acres, or 306 square miles. The total groundwater storage capacity of the Basin is estimated to be 360,000 af. The average annual recharge is estimated to be 200 af (Appendix J of this Initial Study).

During project construction, water will be needed for dust control and soil conditioning during installation of the photovoltaic panels, battery storage units, and related infrastructure. Construction water demand is approximately 145 acre-feet and is anticipated to require 12 months to complete, thus, the monthly water demand during that period would average approximately 12 af. During the operational phase, water will be needed for routine maintenance activities, which will primarily consist of washing the photovoltaic panels to maintain generation efficiency. The operational water demand is anticipated to be 12.5 acre-feet per year. The maintenance activities are anticipated to be conducted up to twice a year over a one-to-two-week period each event, so the maintenance water demand is intermittent and not spread throughout the year (Appendix J of this Initial Study).

The total groundwater storage capacity of the Basin is estimated to be 360,000 af and the groundwater level decline from 1979 to 2018 decreased groundwater storage by approximately six percent. Thus, the current storage in the Basin may be in the range of 335,000 to 340,000 af. The single year construction water demand of 145 af and the annual operational water needs of 12.5 af per year are miniscule (0.04 percent and 0.004 percent, respectively) compared to the available groundwater in storage. Furthermore, the long-term annual operational water needs are much less than the estimated annual recharge of 200 af per year. According to the WSA, there will be sufficient water supply available for existing water uses in the Basin, along with the project water demand during normal, single dry, and multiple dry year periods for the anticipated life of the project (which is anticipated to be 25 to 30 years) (Appendix J of this Initial Study). Therefore, this impact is considered less than significant.

- c) **No Impact.** The proposed project would not generate wastewater that would need to be treated by a wastewater treatment facility. On-site wastewater needs will be accommodated by the use of portable toilets that will be removed from the project site once construction is complete. No impact would occur.
- d) **Less than Significant Impact.** Solid waste generation would be minor for the construction and operation of the proposed project. There are several solid waste facilities within Imperial County and solid waste will be disposed of using a locally-licensed waste hauling service, most likely Allied Waste. Construction waste would likely be hauled to the Niland Solid Waste Site (13-AA-0009) located approximately 6.4 miles southeast of the project site in Niland. The Niland Solid

Waste Site has approximately 211,439 cubic yards of remaining capacity and is estimated to remain in operation through 2046 (CalRecycle n.d.). Therefore, there is ample landfill capacity in the County to receive the minor amount of solid waste generated by construction and operation of the proposed project.

Additionally, because the proposed projects would generate solid waste during construction and operation, they will be required to comply with state and local requirements for waste reduction and recycling, including the 1989 California Integrated Waste Management Act and the 1991 California Solid Waste Reuse and Recycling Access Act of 1991. Also, conditions of the conditional use permits will contain provisions for recycling and diversion of Imperial County construction waste policies. Therefore, a less than significant impact is identified for this issue area.

- e) **Less than Significant Impact.** The proposed project would comply with all applicable statutes and regulations related to solid waste. As discussed in Response XIX. d) above, solid waste generated by the proposed solar facility and BESS is expected to be minimal. This impact is considered less than significant.

XX. Wildfire

Environmental Issue Area:	Potentially Significant Impact	Less than Significant with Mitigation Incorporated	Less Than Significant Impact	No Impact
<i>If located in or near state responsibility areas or lands classified as very high fire hazard severity zones, would the project:</i>				
a) Substantially impair an adopted emergency response plan or emergency evacuation plan?	<input type="checkbox"/>	<input type="checkbox"/>	<input type="checkbox"/>	<input checked="" type="checkbox"/>
b) Due to slope, prevailing winds, and other factors, exacerbate wildfire risks, and thereby expose project occupants to, pollutant concentrations from a wildfire or the uncontrolled spread of a wildfire?	<input type="checkbox"/>	<input type="checkbox"/>	<input type="checkbox"/>	<input checked="" type="checkbox"/>
c) Require the installation or maintenance of associated infrastructure (such as roads, fuel breaks, emergency water sources, power lines or other utilities) that may exacerbate fire risk or that may result in temporary or ongoing impacts to the environment?	<input type="checkbox"/>	<input type="checkbox"/>	<input type="checkbox"/>	<input checked="" type="checkbox"/>
d) Expose people or structures to significant risks, including downslope or downstream flooding or landslides, as a result of runoff, post-fire slope instability, or drainage changes?	<input type="checkbox"/>	<input type="checkbox"/>	<input type="checkbox"/>	<input checked="" type="checkbox"/>

Impact Analysis

- a) – d) **No Impact.** Based on a review of the California Department of Forestry and Fire Protection’s fire hazard severity zone map, the project site is not located within a fire hazard severity zone. The nearest fire hazard severity zone is classified as moderate and located approximately 30 miles northwest of the project site (California Department of Forestry and Fire Protection 2022). The proposed project would not involve blocking or restricting any emergency access routes and would not interfere with emergency response plans or operations near the project area. The proposed project would not involve the development of structures that would introduce new populations to the project area that could result in impacts involving wildfires. The proposed project would not exacerbate wildfire risks and no impact is identified.

XXI. Mandatory Findings of Significance

Environmental Issue Area:	Potentially Significant Impact	Less than Significant with Mitigation Incorporated	Less Than Significant Impact	No Impact
<i>Would the project:</i>				
a) Does the project have the potential to substantially degrade the quality of the environment, substantially reduce the habitat of a fish or wildlife species, cause a fish or wildlife population to drop below self-sustaining levels, threaten to eliminate a plant or animal community, substantially reduce the number or restrict the range of a rare or endangered plant or animal or eliminate important examples of the major periods of California history or prehistory?	<input type="checkbox"/>	<input checked="" type="checkbox"/>	<input type="checkbox"/>	<input type="checkbox"/>
b) Does the project have impacts that are individually limited, but cumulatively considerable ("Cumulatively considerable" means that the incremental effects of a project are considerable when viewed in connection with the effects of past projects, the effects of other current projects, and the effects of probable future projects)?	<input type="checkbox"/>	<input checked="" type="checkbox"/>	<input type="checkbox"/>	<input type="checkbox"/>
c) Does the project have environmental effects, which will cause substantial adverse effects on human beings, either directly or indirectly?	<input type="checkbox"/>	<input type="checkbox"/>	<input checked="" type="checkbox"/>	<input type="checkbox"/>

Impact Analysis

- a) **Less than Significant Impact with Mitigation Incorporated.**

Biological Resources

Special-Status Plants

As described in Response IV. a) above, a total of eight special-status plant species and 12 special-status wildlife species were identified with the potential to occur within or near the project site. One special-status plant species was determined to have a moderate potential to occur: Orocopia sage. Two special-status plant species were determined to have a high potential to occur: Harwood’s milk-vetch and Munz’s cholla. Impacts to these species could be considered significant. Implementation of Mitigation Measures BIO-1 through BIO-3 would reduce potential impacts on special-status species to a level less than significant.

Special-Status Wildlife

Two special-status wildlife species (CDFW SSC species) were observed on site during the habitat assessment: loggerhead shrike and long-eared owl. An additional four species were determined to have a high potential to occur: burrowing owl, pallid bat, Yuma myotis, and desert kit fox and six species were determined to have a moderate potential to occur: Couch's spadefoot, flat-tailed horned lizard, Townsend's big-eared bat, small-footed myotis, fringed myotis, and American badger. Impacts to these species could be considered significant. Implementation of Mitigation Measures BIO-2 through BIO-6 would reduce potential impacts on special-status species to a level less than significant.

There is foraging habitat for a number of raptor species and breeding habitat for numerous passerine species that are protected by the MBTA throughout the project site. Impacts to nesting avian species could be considered significant. Implementation of Mitigation Measures BIO-2, BIO-3, BIO-5 and BIO-6 would reduce potential impacts on nesting avian species to a level less than significant.

A previously occupied bat roost site was documented in an abandoned building and adjacent outhouse structure in the northwest corner of the project site. The evidence of bat use indicated that this building may be a site used by bat maternity colonies. Further, this building provides suitable habitat for CDFW SSC bat species and BLM Sensitive bat species. Impacts to these species and maternity roosting sites could be considered significant. Implementation of Mitigation Measures BIO-2, BIO-3, BIO-7 and BIO-8 would reduce potential impacts on bat species to a level less than significant.

Sensitive Vegetation Communities

As described in Response IV. b) above, sensitive vegetation communities including blue palo verde/ironwood woodland, bush seepweed scrub, and iodine bush scrub are present on-site. Construction activities such as site preparation and grading may result in the removal of vegetation on-site. Implementation of Mitigation Measure BIO-8 would reduce potential impacts to a level less than significant by avoiding sensitive vegetation communities or through implementation of best management practices to minimize potential effects.

Cultural Resources

As described in Response V. a) above, Site P-13-13072 and NS1-09 are evaluated as eligible for the NRHP/CRHR and considered Historical Resources under CEQA. Construction activities associated with the proposed project will include ground disturbing actions that could impact the abovementioned NRHP/CRHR eligible resources. To the maximum extent feasible, the project applicant will design the project to avoid these resources. However, if avoidance is not feasible, the proposed project has the potential to impact these resources and cause a substantial adverse change in the significance of a historical resource pursuant to §15064.5. This potential impact is considered significant. Implementation of Mitigation Measures CR-1 through CR-3 would reduce the potential impact to a level less than significant.

As described in Response V. b) above, due to the presence of alluvium along successive Lake Cahuilla shorelines, and given the likelihood for pre-contact archaeological resources to be located along such shorelines, the project area has the potential for buried pre-contact archaeological resources. There is a high potential for buried pre-contact cultural material along the Lake Cahuilla shorelines because pre-contact resources in this region are known to occur along shorelines, rivers, creeks, and drainages. Therefore, there remains a possibility that unanticipated subsurface discoveries may arise during project construction. This potential impact is considered significant. Implementation of Mitigation Measures CR-2 and CR-3 would reduce potential impacts to a level less than significant.

As described in Response V. c) above, the potential for encountering subsurface human remains within the project site is low, there remains a possibility that human remains are present beneath the ground surface, and that such remains could be exposed during construction. This potential

impact is considered significant. Implementation of Mitigation Measure CR-4 would ensure that the potential impact on previously unknown human remains does not rise to a level of significance pursuant to CEQA.

Geology and Soils

As described in Response I. f) above, the project site is located within an area where paleontological sensitivity is considered to be high. Impacts on any surface or near-surface level paleontological resources may occur because of grading and disturbance of the area. Even relatively shallow excavations in the Lake Cahuilla beds exposed in the project site may encounter significant vertebrate fossil remains. Implementation of Mitigation Measure GEO-1 would ensure that the potential impacts on paleontological resources do not rise to the level of significance pursuant to CEQA.

- b) **Less than Significant Impact with Mitigation Incorporated.** Based on the analysis contained in this Initial Study, the proposed project would not result in significant impacts to aesthetics, agricultural and forestry resources, energy, greenhouse gas emissions, hazards and hazardous materials, hydrology and water quality, land use and planning, mineral resources, noise, population and housing, public services, recreation, transportation, utilities and service systems, and wildfire.

The proposed project would have potential impacts that are significant on the following resources areas: air quality, biological resources, cultural resources, geology and soils, and tribal cultural resources. However, implementation of mitigation measures would ensure potential impacts are reduced to less than significant levels. The proposed project would incrementally contribute to cumulative impacts for projects occurring within the vicinity of the project. However, compliance with the mitigation measures would ensure that no residually significant impacts would result with implementation of the project either directly or indirectly. In the absence of residually significant impacts, the incremental accumulation of effects would not be cumulatively considerable. Therefore, a finding of less than significant is identified for this issue area.

- c) **Less than Significant Impact.** Based on the analysis contained in this Initial Study, the proposed project would not cause substantial adverse effects on human beings, either directly or indirectly. Any effects related to construction of the project would be temporary and short-term and would not result in any long-term or permanent effects on human beings. This is considered a less than significant impact.

References

- California Department of Conservation (DOC). 2023. California Important Farmland Finder. Available on-line at: <https://maps.conservation.ca.gov/DLRP/CIFF/>. Accessed on November 14, 2023.
- n.d. California Earthquake Hazards Zone Application. Accessed on July 20, 2023. <https://maps.conservation.ca.gov/cgs/EQZApp/app/>.
- 2016. Mines Online. Available on-line at <https://maps.conservation.ca.gov/mol/index.html>. Accessed January 3, 2024.
- California Department of Fish and Wildlife (CDFW). 2022. Natural Diversity Data Base – RareFind Version 5 – Computer Version – Dated September 14, 2020 and April 5, 2022. Biogeographic Data Branch.
- 2012. Staff Report on Burrowing Owl Mitigation. March 7.
- California Department of Forestry and Fire Protection. 2022. SRA FHSZ Rollout Application. Available on-line at: <https://calfire-forestry.maps.arcgis.com/apps/webappviewer/index.html?id=fd937aba2b044c3484a642ae03c35677>. Accessed on November 17, 2023.
- California Department of Resources Recycling and Recovery (CalRecycle). n.d. Facility/Site Summary Details: Niland Solid Waste Site (13-AA-0009). <https://www2.calrecycle.ca.gov/SolidWaste/SiteActivity/Details/4184?siteID=596>. Accessed December 12, 2023.
- California Department of Transportation. 2018. California State Scenic Highway System Map. Available on-line at: <https://caltrans.maps.arcgis.com/apps/webappviewer/index.html?id=465dfd3d807c46cc8e8057116f1aaca>. Accessed on July 19, 2023.
- California Department of Toxic Substances Control. n.d. EnviroStor Database. Available on-line at: <https://www.envirostor.dtsc.ca.gov/public/map/>. Accessed on July 24, 2023.
- California Native Plant Society (CNPS). 2022 Inventory of Rare and Endangered Plants (Online edition, v7-08c). Rare Plant Scientific Advisory Committee. Available on-line at: <http://www.cnps.org/inventory>.
- County of Imperial. 2016. Imperial County General Plan. Conservation and Open Space Element.
- 1997. Imperial County General Plan. Seismic and Public Safety Element.
- Federal Emergency Management Agency (FEMA). 2021. Flood Insurance Rate Map, Map Number 06025C1734C). Available on-line at: <https://hazards-fema.maps.arcgis.com/apps/webappviewer/index.html?id=8b0adb51996444d4879338b5529aa9cd>. Accessed on July 24, 2023.
- 2020. Flood Zones. Available on-line at: <https://www.fema.gov/glossary/flood-zones>. Accessed on July 24, 2023.
- Imperial County Transportation Commission (ICTC). 2022. Regional Active Transportation Plan – Final. Available on-line at: <https://www.imperialctc.org/assets/documents/transportation-plans-and->

studies/ICTC-ATP_Final-Document_2022.02.28_Reduced-Size.pdf. Accessed on July 24, 2023.

——— 2023. ICTC LRTP Projects. Available on-line at:
<https://www.arcgis.com/apps/dashboards/d2ab54419c30410287e826360ffdc8ee>. Accessed on July 24, 2023.

Jennings, C.W. 1967. Geologic Map of California: Salton Sea sheet, California Division of Mines and Geology, Geologic Atlas California GAM-13.

State Water Resources Control Board n.d. GeoTracker. Available on-line at:
<https://geotracker.waterboards.ca.gov/map/>. Accessed on July 24, 2023.

United States Department of Agriculture (USDA). n.d. Web Soil Survey. Available on-line at:
<https://websoilsurvey.sc.egov.usda.gov/App/WebSoilSurvey.aspx>. Accessed on July 27, 2023.

United States Fish and Wildlife Service (USFWS). 2022. National Wetlands Inventory (website). U.S. Department of Interior, Fish and Wildlife Service, Washington D.C. Available on-line at:
<http://www.fws.gov/wetlands/>.

List of Preparers

This Initial Study was prepared for the Imperial County Planning and Development Services Department by HDR. The following professionals participated in its preparation:

Imperial County Planning and Development Services Department

Jim Minnick, Planning and Development Services Director

Michael Abraham, AICP, Assistant Planning and Development Services Director

Diana Robinson, Planning Division Manager

Gerardo Quero, Planner II

HDR

Tim Gnibus, Principal

Sharyn Hidalgo, Project Manager

Regan Del Rosario, Environmental Planner

Sharon Jacob, Geographic Information Systems Analyst

Katherine Turner, Document Production Administrator

Technical Report Preparers

ECORP Consulting, Inc.

- Visual Resources Impact Assessment
- Air Quality and Greenhouse Gas Emissions Assessment
- Archaeological and Architectural History Resources Evaluations
- Biological Technical Report
- Energy Consumption Assessment
- Cultural Resources Inventory Report
- Noise Impact Assessment
- Traffic, Parking, and Circulation Assessment
- Water Supply Assessment

Hernandez Environmental Services

- Aquatic Resource Delineation Report

Landmark Consultants, Inc.

- Geotechnical Report

GS Lyons Consultants, Inc.

- Phase I Environmental Site Assessment

Findings

This is to advise that the County of Imperial, acting as the lead agency, has conducted an Initial Study to determine if the project may have a significant effect on the environment and is proposing this Negative Declaration based upon the following findings:

- The Initial Study shows that there is no substantial evidence that the project may have a significant effect on the environment and a **NEGATIVE DECLARATION** will be prepared.

- The Initial Study identifies potentially significant effects but:
 - (1) Proposals made or agreed to by the applicant before this proposed Mitigated Negative Declaration was released for public review would avoid the effects or mitigate the effects to a point where clearly no significant effects would occur.
 - (2) There is no substantial evidence before the agency that the project may have a significant effect on the environment.
 - (3) Mitigation measures are required to ensure all potentially significant impacts are reduced to levels of insignificance.

A **MITIGATED NEGATIVE DECLARATION** will be prepared.

If adopted, the Negative Declaration means that an Environmental Impact Report will not be required. Reasons to support this finding are included in the attached Initial Study. The project file and all related documents are available for review at the County of Imperial, Planning & Development Services Department, 801 Main Street, El Centro, CA 92243 (442) 265-1736.

NOTICE

The public is invited to comment on the proposed Negative Declaration during the review period.

Date of Determination Jim Minnick, Director of Planning & Development Services

The Applicant hereby acknowledges and accepts the results of the Environmental Evaluation Committee (EEC) and hereby agrees to implement all Mitigation Measures, if applicable, as outlined in the MMRP.

Applicant Signature

Date

COMMENT LETTERS



IID

A century of service.

www.iid.com

Since 1911

January 4, 2024

Mr. Gerardo Quero
Planner II
Planning & Development Services Department
County of Imperial
801 Main Street
El Centro, CA 92243

RECEIVED

By Imperial County Planning & Development Services at 4:10 pm, Jan 04, 2024

SUBJECT: NorthStar 1 Solar Energy and BESS Project; GPA23-0001/ZC23-0001/CUP23-0005/CUP23-0006/IS23-0006

Dear Mr. Quero:

On December 22, 2023, the Imperial Irrigation District received from the Imperial County Planning & Development Services Department, a request for agency comments on the NorthStar 1 Solar Energy and Battery Energy Storage System project; General Plan Amendment No.23-0001, Zone Change No. 23-0001, Conditional Use Permit No. 23-0005, Conditional Use Permit No. 23-0006, Initial Study No.23-0006. The applicant, Apex Energy Solution, LLC; proposes the construction and operation of 50MW PV energy generation facility, a 75MW battery storage system and associated off-site transmission upgrades. The nearly 288-acre project site is located at 8997 Wilkins Road, Niland, CA (APNs 003-110-005, -007).

1. If the project requires electrical service, the applicant should be advised to contact Gabriel Ramirez, IID project development service planner, at (760) 339-9257 or e-mail Mr. Ramirez at gramirez@iid.com to initiate the customer service application process. In addition to submitting a formal application (available for download at the district website <http://www.iid.com/home/showdocument?id=12923>), the applicant will be required to submit an AutoCAD file of site plan, approved electrical plans, electrical panel size and panel location, operating voltage, electrical loads, project schedule, and the applicable fees, permits, easements and environmental compliance documentation pertaining to the provision of electrical service to the project. The applicant shall be responsible for all costs and mitigation measures related to providing electrical service to the project.
2. Electrical capacity is limited in the project area. A circuit study may be required. Any system improvements or mitigation identified in the circuit study to enable the provision of electrical service to the project shall be the financial responsibility of the applicant.

3. Applicant shall provide a surveyed legal description and an associated exhibit certified by a licensed surveyor for all rights of way deemed by IID as necessary to accommodate the project electrical infrastructure. Rights-of-Way and easements shall be in a form acceptable to and at no cost to IID for installation, operation, and maintenance of all electrical facilities.
4. The applicant will be required to provide rights of ways and easements for any proposed power line extensions and/or any other infrastructure needed to serve the project as well as the necessary access to allow for continued operation and maintenance of any IID facilities located on adjoining properties.
5. Any construction or operation on IID property or within its existing and proposed right of way or easements including but not limited to: surface improvements such as proposed new streets, driveways, parking lots, landscape; and all water, sewer, storm water, or any other above ground or underground utilities; will require an encroachment permit, or encroachment agreement (depending on the circumstances). A copy of the IID encroachment permit application and instructions for its completion are available at <https://www.iid.com/about-iid/department-directory/real-estate>. The IID Real Estate Section should be contacted at (760) 339-9239 for additional information regarding encroachment permits or agreements. No foundations or buildings will be allowed within IID's right of way.
6. Any new, relocated, modified or reconstructed IID facilities required for and by the project (which can include but is not limited to electrical utility substations, electrical transmission and distribution lines, water deliveries, canals, drains, etc.) need to be included as part of the project's California Environmental Quality Act (CEQA) and/or National Environmental Policy Act (NEPA) documentation, environmental impact analysis and mitigation. Failure to do so will result in postponement of any construction and/or modification of IID facilities until such time as the environmental documentation is amended and environmental impacts are fully analyzed. Any and all mitigation necessary as a result of the construction, relocation and/or upgrade of IID facilities is the responsibility of the project proponent.
7. When the time comes for the project to go through the CEQA process and address the environmental factors to be assessed, pursuant to the checklist in Appendix G of the CEQA guidelines, to correctly evaluate the potential impacts related to the environmental factor "XIX. UTILITIES AND SERVICE SYSTEMS" and determine the appropriate compliance action, a circuit study/distribution impact study, facility study, and/or system impact study will have to be performed to establish if the project will require or result in the relocation or construction of new or expanded electric power facilities, the construction or relocation of which could cause significant environmental effects.

Gerardo Quero
January 4, 2024
Page 3

8. The project is still going through the IID interconnection process and is currently in the Facility Study stage. Within the study, the district is anticipating that instead of a 0.75-mile gen-tie a 0.75-mile in-and-out of IID's 161kV N-Line (not the KN Line) will be required. This line will be brought into an IID switching station planned to be built within the customer's property. The gen-tie will be a short jumper to the IID switching station.

Should you have any questions, please do not hesitate to contact me at 760-482-3609 or at dvargas@iid.com. Thank you for the opportunity to comment on this matter.

Respectfully,



Donald Vargas
Compliance Administrator II

Jamie Asbury – General Manager
Mike Pacheco – Manager, Water Dept.
Matthew H Smelser – Manager, Energy Dept.
Geoffrey Holbrook – General Counsel
Michael P. Kemp – Superintendent General, Fleet Services and Reg. & Environ. Compliance
Laura Cervantes. – Supervisor, Real Estate
Jessica Humes – Environmental Project Mgr. Sr., Water Dept.



Office of the Agricultural Commissioner
Sealer of Weights and Measures
852 Broadway, El Centro CA 92243

Jolene Dessert
Commissioner / Sealer

Rachel Garewal
Asst. Commissioner / Sealer

January 05, 2024

Gerardo Quero, Planner II
Planning & Development Services Department
County of Imperial
801 Main Street
El Centro, CA 92243

Re: Apex Energy Solutions LLC GPA23-0001/ZC23-0001/CUP23-0005, 006/IS23-0006

Dear Mr. Quero:

Our department received and reviewed the documents pertaining to GPA23-0001/ZC23-0001/CUP23-0005, 006/IS23-0006 as submitted by Apex Energy Solutions LLC. The applicant is proposing to construct and operate a 50 megawatt photovoltaic solar energy generation project and 75 megawatt battery energy storage project and associated off-site transmission lines on approximately 288 acres at 8997 Wilkins Rd. Niland, CA.

Any plans to mitigate farmland taken out of production through the use of easements must ensure that the mitigating farm ground is in farmable condition. If the mitigation plan involves a Parceling Project, any parcels to remain in farming must align with existing infrastructure such as canals, delivery ditches, and surface & subsurface drainage systems. Mitigating farmland must be maintained in farmable condition, including repairs as needed to the infrastructure.

This project will require an ongoing Pest Management Plan to mitigate negative impacts to surrounding farmland from pests such as insects, vertebrates, weeds, and plant pathogens. The plan must be submitted to our office for approval prior to the issuance of a grading or building permit, whichever occurs first). Attached are the requirements that your company will need to meet.

Projects constructed on farm ground will also require a reclamation plan that would return the land to its pre-constructed agricultural condition at the conclusion or abandonment of the project. The reclamation plan needs to include a written description of the crop history of each field, water delivery system, drainage system, physical infrastructure, the parties responsible for conducting reclamation, and a detailed description of the recycling, and/or disposal of all solar arrays, inverters, transformers and other structures on each of the sites. The plan must be submitted to our office for approval prior to the issuance of a grading permit.

If you or the applicant has any questions, please contact me at 442-265-1500.

Respectfully,

Jolene Dessert



Office of the Agricultural Commissioner
Sealer of Weights and Measures
852 Broadway, El Centro CA 92243

Jolene Dessert
Commissioner / Sealer

Rachel Garewal
Asst. Commissioner / Sealer

Pest Management Plan Requirements for Solar Projects

The Project Shall:

- Maintain a Pest Management Plan until reclamation is complete.
- Develop and implement a Pest Management Plan that will reduce negative impacts to surrounding (not necessarily adjacent) farmland.
- Monitor for all pests including insects, vertebrates, weeds, and pathogens. Promptly control or eradicate pests when found, or when notified by the Agricultural Commissioner's office that a pest problem is present on the project site. The assistance of a licensed pest control advisor is recommended. All treatments must be performed by a qualified applicator or a licensed pest control business.
- "Control" means to reduce the population of common pests below economically damaging levels, and includes attempts to exclude pests before infestation, and effective control methods after infestation. Effective control methods may include physical/mechanical removal, biocontrol, cultural control, or chemical treatments.
- Use of "permanent" soil sterilants to control weeds or other pests is prohibited due to the fact that this would interfere with reclamation.
- Notify the Agricultural Commissioner's office immediately regarding any suspected exotic/invasive pest species as defined by the California Department of Food Agriculture (CDFA) and the United States Department of Agriculture (USDA). Request a sample be taken by the Agricultural Commissioner's Office of a suspected invasive species. Eradication of exotic pests will be done under the direction of the Agricultural Commissioner's Office and/or CDFA.
- Obey all pesticide use laws, regulations, and permit conditions.
- Allow access by Agricultural Commissioner staff for routine visual and trap pest surveys, compliance inspections, eradication of exotic pests, and other official duties.
- Ensure that all project employees that handle pest control issues are appropriately trained and certified, that all required records are maintained and available for inspection, and that all permits and other required legal documents are current.
- Maintain records of pests found and treatments or pest management methods used. Records should include the date, location/block, project name (current and previous if changed), and methods used. For pesticides include the chemical(s) used, EPA Registration numbers, application rates, etc. A pesticide use report may be used for this.
- Submit a report of monitoring, pest finds, and treatments, or other pest management methods to the Agricultural Commissioner quarterly within 15 days after the end of the previous quarter, and upon request. The report is required even if no pests were found or treatment occurred. It may consist of a copy of all records for the previous quarter, or may be a summary letter/report as long as the original detailed records are available upon request.

Reimbursement

- The project shall reimburse the Agricultural Commissioner's office for the actual cost of investigations, inspections, or other required non-routine responses to the site that are not funded by other sources.

COUNTY EXECUTIVE OFFICE

Miguel Figueroa
County Executive Officer
miguelfigueroa@co.imperial.ca.us
www.co.imperial.ca.us



County Administration Center
940 Main Street, Suite 208
El Centro, CA 92243
Tel: 442-265-1001
Fax: 442-265-1010

January 10, 2024

TO: Gerardo Quero, Planning and Development Services Department

FROM: Rosa Lopez, Executive Office 

SUBJECT: Request for Comments – NorthStar 1 BESS Facility Project / CUP23-0005, 23-0006, APN 003-110-005 & 003-110-007

The County of Imperial Executive Office is responding to a request for comments: NorthStar 1 BESS Facility Project / CUP23-0005, 23-0006, APN 003-110-005 & 003-110-007. The Executive Office would like to inform the developer of conditions and responsibilities of the applicant seeking a Conditional Use Permit (CUP). The conditions commence prior to the approval of an initial grading permit and subsequently continue throughout the permitting process. This includes, but not limited to:

- Sales Tax Guarantee. The permittee is required to have a Construction Site Permit reflecting the project site address, allowing all eligible sales tax payments are allocated to the County of Imperial, Jurisdictional Code 13998. The permittee will provide the County of Imperial a copy of the CDTFAs account number and sub-permit for its contractor and subcontractors (if any) related to the jobsite. Permittee shall provide in written verification to the County Executive Office that the necessary sales and use tax permits have been obtained, prior to the issuance of any grading permits.
- Construction/Material Budget: The permittee will provide the County Executive Office a construction materials budget: an official construction materials budget or detailed budget outlining the construction and materials cost for the processing facility on permittee letterhead.
- At developers cost, the County Executive Office shall hire a third-party consultant to produce a Fiscal and Economic Impact Analysis & Job and Employment Analysis (FEIA & JEIA) prior to project being placed on Planning Commission meeting.
- Public Service Agreement. The developer shall enter into a Public Service Agreement with the County of Imperial.

Should there be any concerns and/or questions, do not hesitate to contact me.



State of California – Natural Resources Agency
DEPARTMENT OF FISH AND WILDLIFE
Inland Deserts Region
3602 Inland Empire Boulevard, Suite C-220
Ontario, CA 91764
www.wildlife.ca.gov

GAVIN NEWSOM, Governor
CHARLTON H. BONHAM, Director



January 17, 2024
Sent via email

Gerardo Quero
Planner II
Imperial County Planning and Development Services
ICPDScommentletters@co.imperial.ca.us

Subject: GPA23-0001/ZC23-0001/CUP23-0005/CUP23-0006/IS23-0006
Apex Energy Solutions
Northstar 1 Solar Energy and Battery Electric Storage System Project

Dear Mr. Quero

On December 22, 2023 the California Department of Fish and Wildlife (CDFW) received a Request for Comments from the Imperial County Planning and Development Services for the General Plan Amendment #23-0001, Zone Change #23-0001, Conditional Use Permit #23-0005 and #23-0006, and Initial Study #23-0006 (Project) pursuant to the California Environmental Quality Act (CEQA) and CEQA Guidelines.¹

Thank you for the opportunity to provide comments and recommendations regarding those activities involved in the Project that may affect California fish and wildlife. Likewise, we appreciate the opportunity to provide comments regarding those aspects of the Project that CDFW, by law, may be required to carry out or approve through the exercise of its own regulatory authority under the Fish and Game Code.

CDFW ROLE

CDFW is California's **Trustee Agency** for fish and wildlife resources and holds those resources in trust by statute for all the people of the state. (Fish & G. Code, §§ 711.7, subd. (a) & 1802; Pub. Resources Code, § 21070; CEQA Guidelines § 15386, subd. (a).) CDFW, in its trustee capacity, has jurisdiction over the conservation, protection, and management of fish, wildlife, native plants, and habitat necessary for biologically sustainable populations of those species. (*Id.*, § 1802.) Similarly, for purposes of CEQA, CDFW is charged by law to provide, as available, biological expertise during public agency environmental review efforts, focusing specifically on projects and related activities that have the potential to adversely affect fish and wildlife resources.

CDFW is also submitting comments as a **Responsible Agency** under CEQA (Pub. Resources Code, § 21069; CEQA Guidelines, § 15381). CDFW expects that it may need to exercise regulatory authority as provided by the Fish and Game Code. As proposed, for example, the Project may be subject to CDFW's lake and streambed alteration regulatory authority. (Fish & G. Code, § 1600 et seq.) Likewise, to the extent implementation of the

¹ CEQA is codified in the California Public Resources Code in section 21000 et seq. The "CEQA Guidelines" are found in Title 14 of the California Code of Regulations, commencing with section 15000.

Gerardo Quero, Planner II
Imperial County Planning and Development Services
January 17, 2024
Page 2

Project as proposed may result in "take" as defined by State law of any species protected under the California Endangered Species Act (CESA) (Fish & G. Code, § 2050 et seq.), the Project proponent may seek related take authorization as provided by the Fish and Game Code.

PROJECT DESCRIPTION SUMMARY

Proponent: Apex Energy Solutions, LLC

Objective: The Applicant proposes the abovementioned General Plan Amendment, Zone Change, Conditional Use Permit and Initial Study for the construction and operation of a 50-megawatt (MW) solar photovoltaic (PV) energy generation project and a 75-MW battery energy storage system (BESS).

Location: The Project would be located in Imperial County on an approximately 288-acre site consisting of two parcels (Assessor's Parcel Numbers 003-11-005 (112 acres) and 003-110-007 (176 acres)) at 8997 Wilkins Road, Niland, CA.

Timeframe: The notification does not indicate a proposed timeframe for construction and/or operational life of the Project.

COMMENTS

The Request for Comments packet included an Aquatic Resource Delineation Report (ARD) and a Biological Technical Report (BRT). CDFW would like to request clarification as to whether the County intends to prepare a document pursuant to the CEQA based on the Initial Study to further analyze potential Project impacts and provide measures to avoid and minimize such impacts. Both the ARD and BRT identify resources subject to CDFW jurisdiction that would be impacted by the proposed Project. The BTR states that the studies were conducted to assess the habitat for its potential to support sensitive plant and wildlife species, and "as required under CEQA, determine whether Project-related impacts would occur to sensitive biological resources" and includes recommendations for mitigation measures; however, nothing else in the packet indicates that any type of CEQA document has been or will be prepared.

The ADR identifies a total of 66.7 acres of ephemeral streams that fall under CDFW jurisdiction that would be impacted by the proposed Project. Fish and Game Code section 1602 requires an entity to notify CDFW prior to commencing any activity that may do one or more of the following: Substantially divert or obstruct the natural flow of any river, stream or lake; Substantially change or use any material from the bed, channel or bank of any river, stream, or lake; or Deposit debris, waste or other materials that could pass into any river, stream or lake. Please note that "any river, stream or lake" includes those that are episodic (i.e., those that are dry for periods of time) as well as those that are perennial (i.e., those that flow year-round). This includes ephemeral streams, desert washes, and watercourses with a subsurface flow. It may also apply to work undertaken within the flood plain of a body of water. Upon receipt of a complete notification, CDFW determines if the proposed Project activities may substantially adversely affect existing fish and wildlife

Gerardo Quero, Planner II
Imperial County Planning and Development Services
January 17, 2024
Page 3

resources and whether a Lake and Streambed Alteration (LSA) Agreement is required. An LSA Agreement includes measures necessary to protect existing fish and wildlife resources. CDFW may suggest ways to modify your Project that would eliminate or reduce harmful impacts to fish and wildlife resources.

CDFW's issuance of an LSA Agreement is a "project" subject to CEQA (see Pub. Resources Code § 21065). To facilitate issuance of an LSA Agreement, if necessary, the CEQA document should fully identify the potential impacts to the lake, stream, or riparian resources, and provide adequate avoidance, mitigation, and monitoring and reporting commitments. Early consultation with CDFW is recommended, since modification of the proposed Project may be required to avoid or reduce impacts to fish and wildlife resources. To obtain a Lake or Streambed Alteration notification package, please go to <https://www.wildlife.ca.gov/Conservation/LSA/Forms>.

Questions regarding this letter or further coordination should be directed to Rose Banks, Senior Environmental Scientist (Specialist) at (760) 218-0022 or Rose.Banks@wildlife.ca.gov.

Sincerely,

DocuSigned by:

Alisa Ellsworth

Environmental Program Manager

AIR POLLUTION CONTROL DISTRICT



January 18, 2024

RECEIVED

By Imperial County Planning & Development Services at 5:11 pm, Jan 25, 2024

Jim Minnick, Director
Imperial County Planning & Development Services
801 Main Street
El Centro, CA 92243

SUBJECT: General Plan Amendment 23-0001, Zone Change 23-0001, Conditional Use Permit 23-0005 & 23-0006 and Initial Study 23-0006 – Apex Energy Solutions

Dear Mr. Minnick:

The Imperial County Air Pollution Control District (Air District) would like to thank you for the opportunity to review and comment on General Plan Amendment (GPA) 23-0001, Zone Change (ZC) 23-0001, and Conditional Use Permits (CUP) 23-0005 & 23-0006, and Initial Study (IS) 23-0006 regarding the proposed construction and operation of a 50 Megawatt (MW) solar photovoltaic (PV) energy generation system and a 75 MW battery energy storage system (BESS) (Project). The Project is located on approximately 288 acres at 8997 Wilkins Rd., Niland also identified with Assessor's Parcel Numbers 003-110-005 & 003-110-007.

After reviewing the Air Quality Assessment (AQA) titled *Air Quality and Greenhouse Gas Emissions Assessments for North Star 1*, the Air District is unable to concur with the CalEEMod analysis and the AQA's determination that impacts will be less than significant as presented due to inconsistencies as detailed below.

Air District staff review all AQAs to ensure consistency with the California Environmental Quality Act (CEQA), the Air District's CEQA Handbook (Handbook), Air District rules & regulations, and enforceability. During the review of the AQA multiple changes to default values of the CalEEMod were noted. Typically, the Air District requests to be consulted on changes to defaults to ensure consistency and enforceability of the analysis. At minimum changes should be sufficiently explained and provide adequate support for the change. While some description of changes to default values are included, the Air District finds that the changes are not sufficiently supported to be consistent with the Air District's guidance.

Of particular interest to the Air District are changes of Road Dust/Percent Pave sections of the CalEEMod from 50% to 97% and finally to 100% in a reanalysis applying mitigation measure AQ-1, the stabilization of the unpaved road portion, to the CalEEMod. Historically, the Air District has allowed for a maximum of 85% due to the high amounts of re-entrained dust on roads in the area and the application of AQ-1 in a reanalysis is not consistent with Air District guidance. CalEEMod includes tools to address this type of mitigation without increasing the Percent Pave defaults. The Air District concludes that changing the defaults to 100% does not provide an accurate representation of real-world conditions in the area and underestimates particulate emissions of the project.

Multiple changes to Fleet Makeup and Fleet Mix factors are not sufficiently explained with supporting information and in combination with changes to default Trip Numbers for Worker, Vendor, and Haul trips, brings into question the accuracy of NO_x emission estimates. As construction activities can generate significant NO_x emissions from equipment and given that solar projects tend to be constructed with relatively shortened timelines, it is imperative the Air District ensure the project does not exceed NO_x thresholds.

Section 2.3.1.1 of the AQA discusses cumulative impacts of the project and states “projects that do not exceed significance thresholds, would not be considered cumulative [sic] considerable.” This interpretation of cumulative impacts is inconsistent with the Air District’s guidance. Section 6.1.f of the Handbook includes the following reference to CEQA regarding cumulative impacts “refers to two or more individual effects which when considered together are considerable ... any cumulative impact analysis should consider the incremental impact of a project added to other closely related past, present and reasonably foreseeable probable future projects.” Solar projects can create significant cumulative emissions of PM₁₀ both during construction and operation.

In order to ensure the project remains below significant impact levels and for the Air District to concur with the less than significant determination with the current AQA, the Air District would require the project comply with the following resolutions:

- Submit an **Enhanced Construction Dust Control Plan** to the Air District for review and approval.
- Submit an **Operational Dust Control Plan** to the Air District for review and approval.
 - Will require site visit to finalize.

- Submit an **Equipment List** periodically during construction to the Air District for review.
 - The list must be in Excel Format and include make, model, year, id/serial number(s), type, tier, horsepower, and actual dates and hours used.
 - Typically submitted electronically on a monthly basis.
 - The Air District will calculate NO_x emissions using Equipment Lists once construction is completed to verify NO_x thresholds were not exceeded.
 - In the event an exceedance is determined the project may become subject to Policy 5 requirements.

If the applicant wishes to instead review and recreate the AQA and CalEEMod for additional review by the Air District, they may pursue that avenue. However, any changes to the above resolutions are contingent upon the Air District's findings after additional review of any changes and updates to the AQA. In any event, the Air District suggests the applicant maintain active communications with the Air District to discuss the resolutions and/or AQA updates.

For your convenience, the Air District's rules and regulations are available via the web at <https://apcd.imperialcounty.org/rules-and-regulations/>. Please feel free to call our office at (442) 265-1800 or contact us through email to setup a discussion regarding the project or if you have any additional questions or concerns.

Respectfully,



Ismael Garcia
Environmental Coordinator



Reviewed by,
Monica Soucier
APC Division Manager

California Department of Transportation

DISTRICT 11
4050 TAYLOR STREET, MS-240
SAN DIEGO, CA 92110
(619) 709-5152 | FAX (619) 688-4299 TTY 711
www.dot.ca.gov



January 18, 2024

11- IMP-111
PM 46.39
NorthStar 1 Solar
GPA, ZC #23-0001
CUP #23-0006, IS #23-0006

Mr. Gerardo Quero
Planner II
County of Imperial
Planning and Development Services
801 Main Street
El Centro, CA 92243

Dear Mr. Quero:

Thank you for including the California Department of Transportation (Caltrans) in the review process for the General Plan Amendment (GPA), Zone Change (ZC), Conditional Use Permit (CUP) and Initial Study (IS) for the NorthStar 1 Solar Project located near State Route 111 (SR-111) in the Niland area. The mission of Caltrans is to provide a safe and reliable transportation network that serves all people and respects the environment. The Local Development Review (LDR) Program reviews land use projects and plans to ensure consistency with our mission and state planning priorities.

Safety is one of Caltrans' strategic goals. Caltrans strives to make the year 2050 the first year without a single death or serious injury on California's roads. We are striving for more equitable outcomes for the transportation network's diverse users. To achieve these ambitious goals, we will pursue meaningful collaboration with our partners. We encourage the implementation of new technologies, innovations, and best practices that will enhance the safety on the transportation network. These pursuits are both ambitious and urgent, and their accomplishment involves a focused departure from the status quo as we continue to institutionalize safety in all our work.

Caltrans is committed to prioritizing projects that are equitable and provide meaningful benefits to historically underserved communities, to ultimately improve transportation accessibility and quality of life for people in the communities we serve.

We look forward to working with the County of Imperial in areas where the County and Caltrans have joint jurisdiction to improve the transportation network and connections between various modes of travel, with the goal of improving the experience of those who use the transportation system.

Caltrans has the following comments:

Hauling

Caltrans has discretionary authority with respect to highways under its jurisdiction and may, upon application and if good cause appears, issue a special permit to operate or move a vehicle or combination of vehicles or special mobile equipment of a size or weight of vehicle or load exceeding the maximum limitations specified in the California Vehicle Code. The Caltrans Transportation Permits Issuance Branch is responsible for the issuance of these special transportation permits for oversize/overweight vehicles on the State Highway network. Additional information is provided online at: <http://www.dot.ca.gov/trafficops/permits/index.html>

Environmental

Caltrans welcomes the opportunity to be a Responsible Agency under the California Environmental Quality Act (CEQA), as we have some discretionary authority of a portion of the project that is in Caltrans' R/W through the form of an encroachment permit process. Please indicate our status as a Responsible Agency for the Final Environmental Document. We look forward to the coordination of our efforts to ensure that Caltrans can adopt the alternative and/or mitigation measure for our R/W. We would appreciate meeting with you to discuss the elements of the Environmental Document that Caltrans will use for our subsequent environmental compliance.

An encroachment permit will be required for any work within the Caltrans' R/W prior to construction. As part of the encroachment permit process, the applicant must provide approved final environmental documents for this project that include the work in Caltrans' R/W, corresponding technical studies, and necessary regulatory and resource agency permits. Specifically, CEQA determination or exemption. The supporting documents must address all environmental impacts within the Caltrans' R/W and address any impacts from avoidance and/or mitigation measures.

We recommend that this project specifically identifies and assesses potential impacts caused by the project or impacts from mitigation efforts that occur within Caltrans R/W that includes impacts to the natural environment, infrastructure (highways/roadways/on- and off-ramps) and appurtenant features (lighting/signs/guardrail/slopes). Caltrans is interested in the analysis for any work

Mr. Gerardo Quero, Planner II
January 18, 2024
Page 3

identified in Caltrans R/W and any additional mitigation measures identified for the Final Environmental Document.

Right-of-Way

- Per Business and Profession Code 8771, perpetuation of survey monuments by a licensed land surveyor is required, if they are being destroyed by any construction.
- Any work performed within Caltrans' R/W will require discretionary review and approval by Caltrans and an encroachment permit will be required for any work within the Caltrans' R/W prior to construction.

Additional information regarding encroachment permits may be obtained by contacting the Caltrans Permits Office at (619) 688-6158 or emailing D11.Permits@dot.ca.gov or by visiting the website at <https://dot.ca.gov/programs/traffic-operations/ep>. Early coordination with Caltrans is strongly advised for all encroachment permits.

If you have any questions or concerns, please contact Mark McCumsey, LDR Coordinator, at (619) 985-4957 or by e-mail sent to Mark.McCumsey@dot.ca.gov.

Sincerely,

Kimberly D. Dodson

KIMBERLY D. DODSON, G.I.S.P.
Acting Branch Chief
Local Development Review

AGUA CALIENTE BAND OF CAHUILLA INDIANS

TRIBAL HISTORIC PRESERVATION



03-015-2024-001

February 01, 2024

[VIA EMAIL TO:gerardoquero@co.imperial.ca.us]
Imperial County
Gerardo Quero
801 Main St.
El Centro, CA 92243

Re: NorthStar 1 PV Solar & Bess

Dear Gerardo Quero,

The Agua Caliente Band of Cahuilla Indians (ACBCI) appreciates your efforts to include the Tribal Historic Preservation Office (THPO) in the NorthStar 1 PV Solar & Bess project. The project area is not located within the boundaries of the ACBCI Reservation. However, it is within the Tribe's Traditional Use Area. A records check of the ACBCI registry indicates this area has not been surveyed for cultural resources. In consultation, the ACBCI THPO requests the following:

- *Formal government to government consultation under California Senate Bill 18 (SB-18).
- *Copies of any cultural resource documentation (report and site records) generated in connection with this project.
- *A cultural resources inventory of the project area by a qualified archaeologist prior to any development activities in this area.
- *A copy of the records search with associated survey reports and site records from the information center.
- *The presence of an archaeologist that meets the Secretary of Interior's standards during any ground disturbing activities.
- *The presence of an approved Cultural Resource Monitor(s) during any ground disturbing activities (including archaeological testing and surveys). Should buried cultural deposits be encountered, the Monitor may request that destructive construction halt and the Monitor shall notify a Qualified Archaeologist (Secretary of the Interior's Standards and Guidelines) to investigate and, if necessary, prepare a mitigation plan for submission to the State Historic Preservation Officer.

Again, the Agua Caliente appreciates your interest in our cultural heritage. If you have questions or require additional information, please call me at (760) 883-1134. You may also email me at ACBCI-THPO@aguacaliente.net.

AGUA CALIENTE BAND OF CAHUILLA INDIANS

TRIBAL HISTORIC PRESERVATION



Cordially,

Claritsa Duarte

Claritsa Duarte
Cultural Resources Analyst
Tribal Historic Preservation Office
AGUA CALIENTE BAND
OF CAHUILLA INDIANS

Gerardo Quero

From: Ray Teran <rteran@viejas-nsn.gov>
Sent: Friday, 2 February, 2024 4:06 PM
To: Gerardo Quero
Cc: Ernest Pingleton; alan hatcher
Subject: NorthStar 1, 2 and 3

CAUTION: This email originated outside our organization; please use caution.

The Viejas Band of Kumeyaay Indians ("Viejas") has reviewed the proposed project and at this time we have determined that the project site has cultural significance or ties to Viejas. Cultural resources have been located within or adjacent to the APE-DE of the proposed project.

Viejas Band request that a Kumeyaay Cultural Monitor be on site for ground disturbing activities and to inform us of any new developments such as inadvertent discovery of cultural artifacts, cremation sites, or human remains.

If you wish to utilize Viejas cultural monitors (Viejas rate is \$54.15/hr. plus GSA mileage), please call Ernest Pingleton at 619-655-0410 or email, epingleton@viejas-nsn.gov, for contracting and scheduling. Thank you.

If a Tribe, having a closer proximity to the Project, requests to perform cultural monitoring, Viejas will differ to them.

Ray Teran

Viejas Tribal Government
Resource Management Director
619-659-2312
rteran@viejas-nsn.gov



RECEIVED

FEB 02 2024

IMPERIAL COUNTY
PLANNING & DEVELOPMENT SERVICES

ADMINISTRATION / TRAINING

1078 Dogwood Road
Heber, CA 92249

Administration

Phone: (442) 265-6000
Fax: (760) 482-2427

Training

Phone: (442) 265-6011

**OPERATIONS/PREVENTION**

2514 La Brucherie Road
Imperial, CA 92251

Operations

Phone: (442) 265-3000
Fax: (760) 355-1482

Prevention

Phone: (442) 265-3020

February 26, 2024

RECEIVED

By Imperial County Planning & Development Services at 1:18 pm, Feb 26, 2024

RE: Apex Energy Solutions, LLC, Northstar 1

Imperial County Fire Department Fire Prevention Bureau would like to thank you for the opportunity to review and comment on Northstar 1 Solar Energy Project and Battery Electric Storage Systems (BESS). GPA #23-0001, ZC#23-0001, CUP#23-0005, CUP#23-0006, IS#23-0006

The project description is developing and operating a one hundred and fifty (150) megawatt (MW) alternating current (AC) solar photovoltaic (PV) energy generation and seventy-five (75) megawatt (MW) battery storage project. This project is located on approximately 288 acres on APN: 003-110-005 and 003-110-007. The location current address is 8997 Wilkins Road, Niland CA 92257

Energy storage facilities create extreme hazards for firefighters and emergency responders with the possibility of explosions, flammable gases, toxic fumes, water-reactive materials, electrical shock, corrosives, and chemical burns. Due to limited resources, the hazards listed can create potential significant impacts for fire department personnel to safely perform firefighting operations and hazardous material response to a utility-scale energy storage facility. The remote location of the project will result longer response times. These long response times may result in incidents that are more difficult to stabilize and requiring additional resources to manage safely. Utility-scale energy storage requires specialized and reliable equipment to perform firefighting operations safely and effectively to NFPA recommendations, OSHA requirements, and ICFD standards.

Standards and requirements for energy storage system includes but not limited to:

NFPA:

- 1 Fire Code
- 70 National Electrical Code
- 855 Standard for the installation of Energy Storage System
- 111 Stored Electrical Energy Emergency and Standby Power System
- 1710 Standard for Organization and Deployment of Fire Suppression Operations, Emergency Medical Operations, and Special Operations to the Public by Career Fire Departments.

OSHA:

- 29 CFR 1910.134(g)(4)

AN EQUAL OPPORTUNITY/AFFIRMATIVE ACTION EMPLOYER

ADMINISTRATION / TRAINING

1078 Dogwood Road
Heber, CA 92249

Administration

Phone: (442) 265-6000
Fax: (760) 482-2427

Training

Phone: (442) 265-6011

**OPERATIONS/PREVENTION**

2514 La Brucherie Road
Imperial, CA 92251

Operations

Phone: (442) 265-3000
Fax: (760) 355-1482

Prevention

Phone: (442) 265-3020

CFC:

Chapter 12 section 1206 Electrical Energy Storage System
Chapter 9 Fire Protection and Life Safety System

Fire Department requirements are the following:

Solar Requirements

- Approved all-weather access roads for fire protection vehicles shall be provided throughout the project, conforming with the California Fire Code Chapter 5, section 503. Access roadways shall be all-weather surface (suitable for use by fire apparatus) right-of-way not less than 20 feet in width.
- Access roadways shall provide intersecting roadways to allow unobstructed movement of fire apparatus throughout the project site. Solar array layout shall meet Imperial County Fire Department layout requirements.
- Additional access shall be provided to the project site in accordance with the California Fire Code Chapter 5, section 503.
- KNOX Box and/or Locks will be required for all access gates as determined by Imperial County Fire Department.
- Solar array fields shall be clear of all vegetation.
- A pre-incident plan shall be developed and approved by the Imperial County Fire/OES Department in a format and using a platform determined by ICFD.

Battery Energy Storage Systems

- An approved water supply capable of supplying the required fire flow determined by appendix B in the California Fire Code shall be installed and maintained. (Minimum fire flow of 1500 GPM for 2 hours) Private fire service mains and appurtenance shall be installed in accordance with NFPA 20, 22, 24
- An approved automatic fire suppression system shall be installed on all required structures as per the California Fire Code Chapter 12 and NFPA 855. All fire suppression systems will be installed and maintained to the current adapted fire code and regulations.
- An approved automatic fire detection system shall be installed on all required structures as per the California Fire Code Chapter 12 and NFPA 855. All fire detection systems will be installed and maintained to the current adapted fire code and regulations.

AN EQUAL OPPORTUNITY/AFFIRMATIVE ACTION EMPLOYER

ADMINISTRATION / TRAINING

1078 Dogwood Road
Heber, CA 92249

Administration

Phone: (442) 265-6000
Fax: (760) 482-2427

Training

Phone: (442) 265-6011

**OPERATIONS/PREVENTION**

2514 La Brucherie Road
Imperial, CA 92251

Operations

Phone: (442) 265-3000
Fax: (760) 355-1482

Prevention

Phone: (442) 265-3020

- Owners and operators of ESS must develop and Emergency Operation Plan in conjunction with local fire service personnel, the AHJ, and hold a comprehensive understanding of the hazards associated with lithium-ion battery technology. Lithium-ion battery ESS's must incorporate adequate explosion prevention protection in accordance with NFPA 855 and/or California Fire Code Chapter 12.
- Signage shall be provided in accordance California Fire Code Chapter 12
- Compliance with all required sections of the fire code.
- Applicant shall provide product containment areas(s) for both product and water run-off in case of fire applications and retained for removal.
- An emergency response/action plan shall be prepared and approved by the Imperial County Fire/OES Department.
- A Hazardous Waste Material Plan shall be submitted to Certified Unified Program Agency (CUPA) for their review and approval.
- All hazardous material and wastes shall be handled, store, and disposed as per the approved Hazardous Waste Materials Plan. All spills shall be documented and reported to Imperial County Fire Department and CUPA as required by the Hazardous Waste Material Plan

Again thank you for the opportunity to comment. Imperial County Fire Department reserves the right to comment and request additional requirements pertaining to this project regarding fire and life safety measures, California building and fire code, and National Fire Protection Association standards at a later time as we see necessary.

If you have any questions, please contact the Imperial County Fire Prevention Bureau at 442-265-3020 or 442-265-3021.

Sincerely

Andrew Loper
Lieutenant/Fire Prevention Specialist
Imperial County Fire Department
Fire Prevention Bureau

Robert Malek
Deputy Chief
Imperial County Fire Department
Fire Prevention Bureau

AN EQUAL OPPORTUNITY/AFFIRMATIVE ACTION EMPLOYER

ADMINISTRATION / TRAINING

1078 Dogwood Road
Heber, CA 92249

Administration
Phone: (442) 265-6000
Fax: (760) 482-2427

Training
Phone: (442) 265-6011



OPERATIONS/PREVENTION

2514 La Brucherie Road
Imperial, CA 92251

Operations
Phone: (442) 265-3000
Fax: (760) 355-1482

Prevention
Phone: (442) 265-3020

CC: David Lantzer Fire Chief
Imperial County Fire Department

General Layout for Road Access

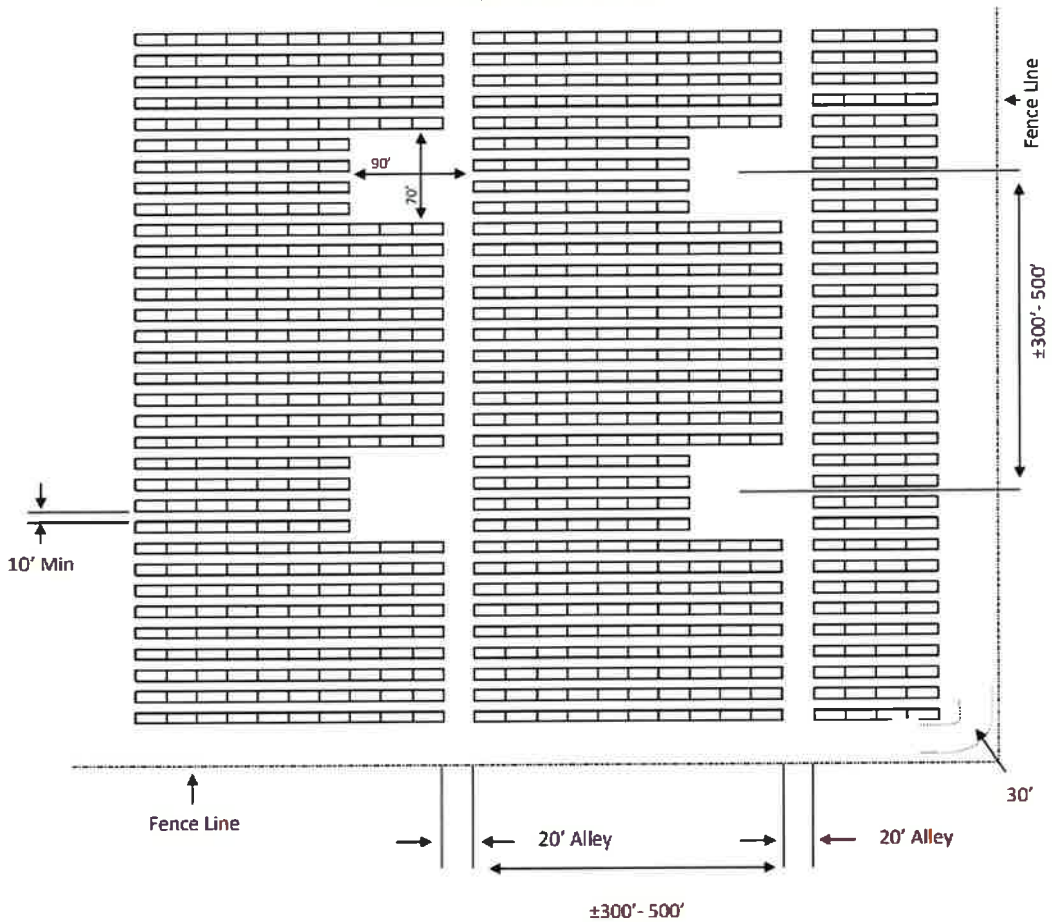

**APPLICATION PACKAGE &
SUPPORTING DOCUMENTS**

Clerical,

Please attach the following documents in the following order (Numbered Already):

ALL DOCUMENTS MAY BE FOUND AT:

**S:\AllUsers\APN\003\110\005\GPA23-0001 ZC23-0001
CUP23-0005 CUP23-0006 IS23-0006\NORTHSTAR 1
SES CD SUBMITTALProject**

- 1. Description and Site Plans**
- 2. Applications**
- 3. ALTA Survey**
- 4. Project Regional Map**
- 5. Project Vicinity Map**
- 6. Common Noise Levels**
- 7. Project Onsite Noise Source Propagation**
- 8. ESA Report**
- 9. Geotechnical Report**
- 10. Project Energy Consumption Assessment**
- 11. Site Access Map**
- 12. Site Map**
- 13. Aquatic Resources Delineation Report**
- 14. Biological Technical Report**
- 15. Transportation Study**
- 16. Water Supply Assessment**
- 17. Air Quality/Greenhouse Gas/Emissions Assessment**
- 18. Noise Assessment**
- 19. Visual Resources Assessment**
- 20. Equipment Site Plan**

Should you have any questions, please contact me.

-GQ#345

**Project Description
For the
NorthStar1PV/BESS**

INTRODUCTION:

The NorthStar 1 Solar Energy Project and Battery Electric Storage System (BESS) (Project), includes the construction of a 50 -megawatt (MW) alternating current solar field and a 75 MW BESS, on approximately 288 acres of vacant land on two parcels in Imperial County, California (APN 003-110-005 @ 112 AC and APN 003-110-007 @ 176 AC .

PROJECT OVERVIEW:

The Project proposes to construct a 50-megawatt (MW) alternating current solar field, consisting of 110,250 single axis tracker modules in 3675 strings and associated collector and inverter facilities, and a 75 MW BESS, on approximately 288 acres of vacant land. The Project would connect to the grid offsite through an approximately .75 -mile gen-tie line to the 161 kV KN IID transmission line near the Coachella Canal. Operational water supply for the Project would be via a proposed groundwater well. Parcel 003-110-005 is within the County's Renewable Energy and Transmission (RE) Element however APN 003-110-007 is not and therefore, an amendment to the County's General Plan will be needed to include and classify the Project Site within the RE Overlay Zone. Additionally, a CUP to allow construction and operation of the solar energy generation facility with battery storage within the RE Overlay Zone will be required to implement the Project.

PROJECT LOCATION:

The total combined Project Site, consisting of two separate parcels of 288 acres in size is located SW of the Coachella Canal northwest of the town of Niland. east of. The Site is currently vacant, undeveloped land, and is surrounded by Open Space on three sides with some minor agricultural development on one side.. The California Department of Conservation's Imperial County Important Farmland Map (2018) categorizes the parcels as "Other Land," indicating that they are not considered important farmland under any category (Prime Farmland, Farmland of Statewide Importance, Unique Farmland, or Farmland of Local Importance). Attached is the site plan (EXHIBIT A) and the gentie map (EXHIBIT B).

GENTIE CONNECTION:

To connect this project to the IID (Imperial Irrigation District) grid, a gentie line approximately .75 to 1.25 mile in length across the adjacent (to the northeast) BLM owned land will be required. This will require the concurrent processing of an application with BLM for the necessary Right of Way.

ACCESS to PROJECT SITE:

The site can be accessed from HWY 111 . The project proposes to construct an entrance near the southwest corner of the project site by constructing a access entry. The access to the site will be gated and only authorized entities will be allowed access. An encroachment permit from CALTRANS will be required for the project.

**Project Description
For the
NorthStar1PV/BESS**

BESS:

As noted above a 75 MW battery system is being proposed with this project. The location of the BESS will be along the north east side of project. The type of battery system is yet to be finalized however more than likely it will be the TESLA Megawall or equal type of system. This will not be a battery system within a conventional building.

SECURITY:

The entire site will be fenced with a 6 ft. high chain linked fence with secured access gate. In addition, this site is entirely remotely operated and will have a full video surveillance security system. Given that these type of projects are self monitored and given that they are secured by the operators there is minimal if no need for police services. At most if an incident occurred at the site the sheriff's office may receive a call for service in which case the project will pay all direct costs for such service.

FIRE PROTECTION:

This is a PV/BESS project that is located in a remote area of the County. The project will meet all County Fire Department requirements. However there will be limited need for actual fire protection in case of a fire insofar as the battery system will be the type that needs to burn to the ground rather than have water applied. These type of battery systems are in open areas and are designed not to be extinguished. In fact attempting to extinguish them creates additional problem with longer burn times and more obnoxious smoke. At most the fire department would need to perform stand by services to prevent the fire from spreading to adjacent property. Given however that adjacent lands are open space desert with no structures at most the fire department would need to minimize brush fires. There will be two 10,000 gallon water storage tanks located on site at location(s) determined by the fire dept. these tanks will be maintained full at all times for fire protection purposes only.

OPERATIONS:

This project once constructed will have no on site personnel nor on site offices. At most there may be a small storage building to house limited supplies. During normal operations there will be routine maintenance which would be performed by one or two individuals going to the site. In addition, there will be rare need for washing the panels. This may occur once each year at most.

WATER SOURCE:

Given that this site is outside of the IID's irrigated district boundary, water cannot be obtained from any of the IID delivery canals unless IID policies change. In order to provide water for the construction and on going operations a water will need to be provided. A separate CUP application has been submitted for this project to drill and operate a water well.

**Project Description
For the
NorthStar3PV/BESS**

INTRODUCTION:

The NorthStar 3 Solar Energy Project and Battery Electric Storage System (BESS) (Project), includes the construction of a 100 -megawatt (MW) alternating current solar field and a 150 MW BESS, on approximately 585 acres of vacant land on two parcels in Imperial County, California (017-350-027 @ 120 AC and APN 017-350--31 @ 305 AC and 017-350-030 @ 160 AC) .

PROJECT OVERVIEW:

The Project proposes to construct a 100-megawatt (MW) alternating current solar field, consisting of 226800 single axis tracker modules in 7560 strings and associated collector and inverter facilities, and a 75 MW BESS, on approximately 585 acres of vacant land. The Project would connect to the grid offsite through an approximately .75 -mile gen-tie line to the 161 kV L IID transmission line which bisects the property. Operational water supply for the Project would be via a proposed groundwater well. None of the parcels are within the County's Renewable Energy and Transmission (RE) Element therefore, an amendment to the County's General Plan will be needed to include and classify the Project Site within the RE Overlay Zone. Additionally, a CUP to allow construction and operation of the solar energy generation facility with battery storage within the RE Overlay Zone will be required to implement the Project.

PROJECT LOCATION:

The total combined Project Site, consisting of three separate parcels of 585acres in size is located N HWY 86 southeast of Salton City. The Site is currently vacant, undeveloped land, and is surrounded by Open Space on all. Attached is the site plan (EXHIBIT A) and the gentie map (EXHIBIT B).

GENTIE CONNECTION:

To connect this project to the IID (Imperial Irrigation District) grid, a connection will be made to the on-site "L" line.

ACCESS to PROJECT SITE:

The site can be accessed from HWY 86 . The project proposes to construct an entrance near the southwest corner of the project site by constructing a commercial grade access entry. The access to the site will be gated and only authorized entities will be allowed access. An encroachment permit from CALTRANS will be required for the project.

BESS:

As noted above a 150 MW battery system is being proposed with this project. The location of the BESS will be along the north east side of project. The type of battery system is yet to be finalized however more than likely it will be the TESLA Megawall or equal type of system. This will not be a battery system within a conventional building.

**Project Description
For the
NorthStar3PV/BESS**

SECURITY:

The entire site will be fenced with a 6 ft. high chain linked fence with secured access gate. In addition, this site is entirely remotely operated and will have a full video surveillance security system. Given that these type of projects are self monitored and given that they are secured by the operators there is minimal if no need for police services. At most if an incident occurred at the site the sheriff's office may receive a call for service in which case the project will pay all direct costs for such service.

FIRE PROTECTION:

This is a PV/BESS project that is located in a remote area of the County. The project will meet all County Fire Department requirements. However there will be limited need for actual fire protection in case of a fire insofar as the battery system will be the type that needs to burn to the ground rather than have water applied. These type of battery systems are in open areas and are designed not to be extinguished. In fact attempting to extinguish them creates additional problem with longer burn times and more obnoxious smoke. At most the fire department would need to perform stand by services to prevent the fire from spreading to adjacent property. Given however that adjacent lands are open space desert with no structures at most the fire department would need to minimize brush fires. There will be two 10,000 gallon water storage tanks located on site at location(s) determined by the fire dept. these tanks will be maintained full at all times for fire protection purposes only.

OPERATIONS:

This project once constructed will have no on site personnel nor on site offices. At most there may be a small storage building to house limited supplies. During normal operations there will be routine maintenance which would be performed by one or two individuals going to the site. In addition, there will be rare need for washing the panels. This may occur once each year at most.

WATER SOURCE:

Given that this site is outside of the IID's irrigated district boundary, water cannot be obtained from any of the IID delivery canals unless IID policies change. In order to provide water for the construction and on going operations a water will need to be provided. A separate CUP application has been submitted for this project to drill and operate a water well.

NORTHSTAR 1

CONFIDENTIAL DOCUMENTS
 THESE DRAWINGS AND SPECIFICATIONS ARE THE PROPERTY OF ZGLOBAL. NO PART OF THIS DOCUMENT IS TO BE REPRODUCED OR TRANSMITTED IN ANY FORM OR BY ANY MEANS, ELECTRONIC OR MECHANICAL, WITHOUT THE WRITTEN CONSENT OF ZGLOBAL, INC.

REV.	BY	DESCRIPTION	DATE	APP'D
1	MD	UPDATED GENTIE	08/22/22	IP

1 inch
 Scale to Center Point

ZGLOBAL
 Power Engineering & Energy Solutions
 604 SLITTER ST, STE 200
 FOLSOM, CA 95630
 Phone : 916.985.9461
 Fax : 916.985.9467

THESE DRAWINGS AND SPECIFICATIONS MAKE NO WARRANTY OF ANY KIND, EXPRESS OR IMPLIED, INCLUDING BUT NOT LIMITED TO, THE IMPLIED WARRANTIES OF MERCHANTABILITY AND FITNESS FOR A PARTICULAR PURPOSE. THESE DRAWINGS AND SPECIFICATIONS ARE THE PROPERTY OF ZGLOBAL AND ARE TO BE USED EXCLUSIVELY IN ACCORDANCE WITH SECTION 319 OF THE CIVIL CODE OF CALIFORNIA.

SHEET TITLE

SITE PLAN

DATE:	1
SCALE:	AS SHOWN
CHECKED BY:	IP
NO. OF SHEETS:	1



PROJECT SUBSTATION

PROJECT GENTIE
 60 FT ROW
 REQUIRED
 THROUGH BLM
 LAND

BATTERIES (TYP)

PV MODULES (TYP)

PROPERTY BOUNDARY

APN: 003-10-005 111 ACRES

APN: 003-110-007
178 ACRES

DC SYSTEM SIZE	71.1 MW	PITCH	17 FT	PV INVERTER	Sungrow 2500KW
AC SYSTEM SIZE	50 MW PV	MODULE	CHSM66M(DG)/F- BH 645	# OF PV INVERTER	20
DC STORAGE SIZE	75 MW	# OF MODULES	110,250	BATT INVERTER	TBD
ARRAY TYPE	TRACKER	STRING SIZE	30	# OF BATT INVERTER	TBD
UTILITY	IID	# OF STRINGS	3675	PV ENERGY MWH / YR	155,663

NORTHSTAR - 1

NORTHSTAR 1

CONFIDENTIAL DOCUMENTS
 THIS DRAWING IS THE PROPERTY OF ZG GLOBAL. IT IS TO BE USED ONLY FOR THE PROJECT AND SITE SPECIFICALLY IDENTIFIED HEREIN. IT IS NOT TO BE REPRODUCED OR TRANSMITTED IN ANY FORM OR BY ANY MEANS, ELECTRONIC OR MECHANICAL, INCLUDING PHOTOCOPYING, RECORDING, OR BY ANY INFORMATION STORAGE AND RETRIEVAL SYSTEM, WITHOUT THE WRITTEN PERMISSION OF ZG GLOBAL, INC.

REV.	BY	DESCRIPTION	DATE	APPROVED
0	RD	SUBMITAL #1	2/20/22	JEP
1	RD	UPDATED DANCE	5/24/22	JEP

Scale: 1 inch = 200 feet
 Scale to Center of Foot Print

ZGLOBAL
 Project Engineers & Architects, S.UTAH'S
 604 SUTTER ST, STE 250
 FOLSOM, CA 95630
 Phone - 916.985.9461
 Fax - 916.985.9407

THESE DRAWINGS AND SPECIFICATIONS HAVE BEEN PREPARED BY AN ENGINEER OR ARCHITECT LICENSED IN THE STATE OF CALIFORNIA. THE ENGINEER OR ARCHITECT IS NOT PROVIDING ANY PROFESSIONAL ENGINEERING OR ARCHITECTURAL SERVICES TO THE STATE OF CALIFORNIA.

ACCESS ROAD

DRAWN BY:	CHECKED:	NO.	DATE:

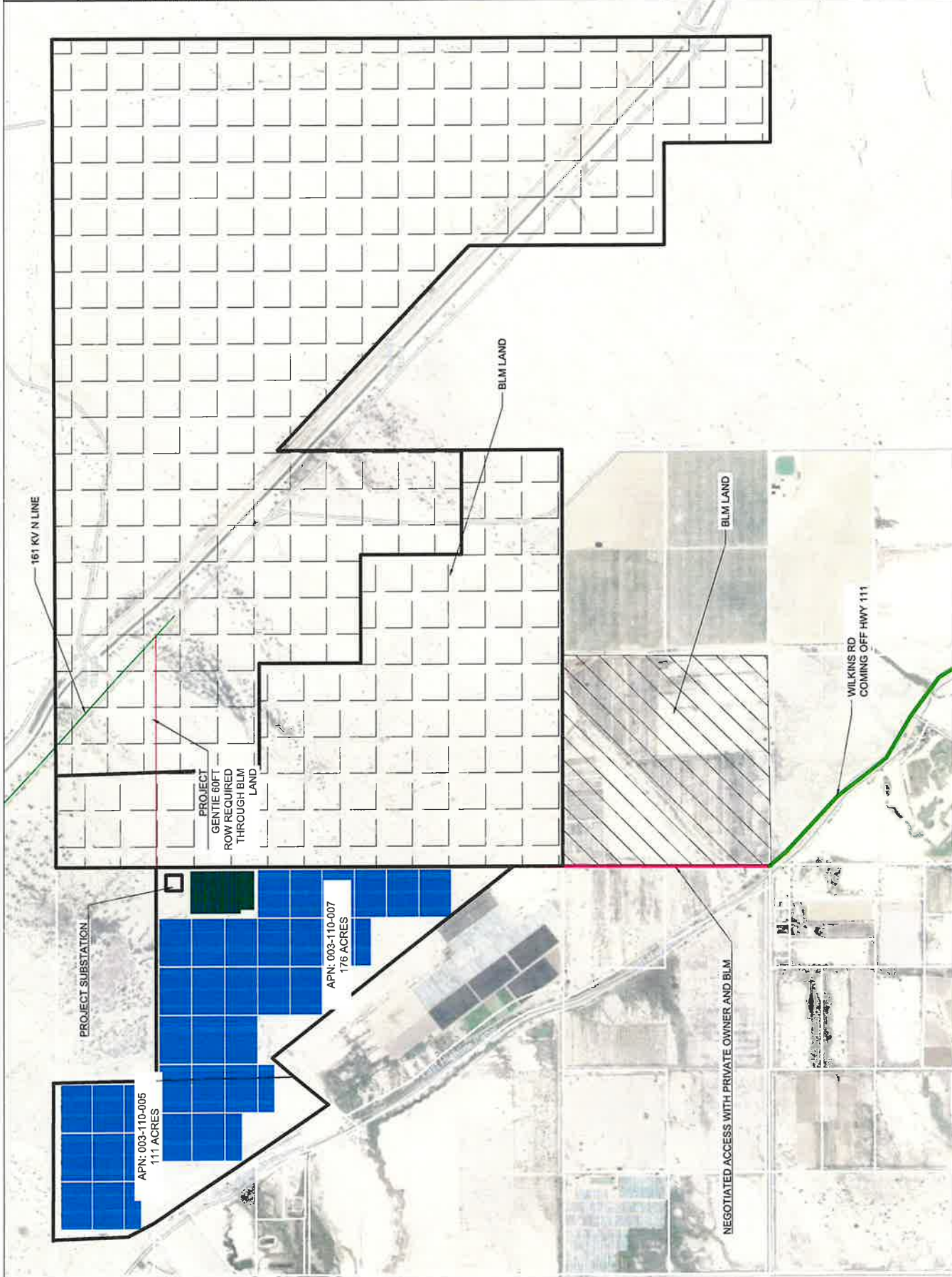

161 KV N LINE

PROJECT SUBSTATION

APN: 003-110-005
111 ACRES

PROJECT GENTLE 60FT ROW REQUIRED THROUGH BLM LAND

APN: 003-110-007
176 ACRES

BLM LAND

BLM LAND

WILKINS RD COMING OFF HWY 111

NEGOTIATED ACCESS WITH PRIVATE OWNER AND BLM

1 inch = 200 feet

CONDITIONAL USE PERMIT

I.C. PLANNING & DEVELOPMENT SERVICES DEPT.
801 Main Street, El Centro, CA 92243 (760) 482-4236

- APPLICANT MUST COMPLETE ALL NUMBERED (black) SPACES - Please type or print -

1. PROPERTY OWNER'S NAME Apex Energy Solutions, LLC		EMAIL ADDRESS c/o Jurgheuberger@gmail.com	
2. MAILING ADDRESS (Street / P O Box, City, State) 604 Sutter St., Suite 250, Folsom, CA		ZIP CODE 95630	PHONE NUMBER 760-996-0313
3. APPLICANT'S NAME Northstar 1 SES (Project Name)		EMAIL ADDRESS NA	
4. MAILING ADDRESS (Street / P O Box, City, State) same		ZIP CODE	PHONE NUMBER
4. ENGINEER'S NAME NA		CA. LICENSE NO.	EMAIL ADDRESS
5. MAILING ADDRESS (Street / P O Box, City, State) NA		ZIP CODE	PHONE NUMBER
6. ASSESSOR'S PARCEL NO. 003-110-005 & 003-110-007		SIZE OF PROPERTY (in acres or square foot) 112 Ac and 176 ac	ZONING (existing) S-2
7. PROPERTY (site) ADDRESS pending			
8. GENERAL LOCATION (i.e. city, town, cross street) see attached data (northwest of Niland)			
9. LEGAL DESCRIPTION See attached title report			

PLEASE PROVIDE CLEAR & CONCISE INFORMATION (ATTACH SEPARATE SHEET IF NEEDED)

10. DESCRIBE PROPOSED USE OF PROPERTY (list and describe in detail)	
develop a solar power project with a battery storage system at approximately 50 MW and 75 MW storage	
11. DESCRIBE CURRENT USE OF PROPERTY	vacant
12. DESCRIBE PROPOSED SEWER SYSTEM	NA
13. DESCRIBE PROPOSED WATER SYSTEM	NA
14. DESCRIBE PROPOSED FIRE PROTECTION SYSTEM	meet county fire standards
15. IS PROPOSED USE A BUSINESS? <input type="checkbox"/> Yes <input type="checkbox"/> No	IF YES, HOW MANY EMPLOYEES WILL BE AT THIS SITE? construction approx. 150, operations about 1-2

I / WE THE LEGAL OWNER (S) OF THE ABOVE PROPERTY CERTIFY THAT THE INFORMATION SHOWN OR STATED HEREIN IS TRUE AND CORRECT.

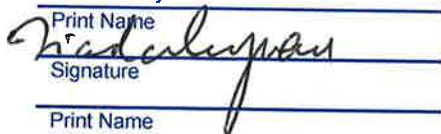
Ziad Alaywan
 Print Name _____
 Signature 
 March 20, 2023
 Date _____

 Print Name _____

 Signature _____

REQUIRED SUPPORT DOCUMENTS

A. SITE PLAN	_____
B. FEE	_____
C. OTHER	_____
D. OTHER	_____

APPLICATION RECEIVED BY: _____	DATE _____	REVIEW / APPROVAL BY OTHER DEPT'S required.
APPLICATION DEEMED COMPLETE BY: _____	DATE _____	<input type="checkbox"/> P. W.
APPLICATION REJECTED BY: _____	DATE _____	<input type="checkbox"/> E. H. S.
TENTATIVE HEARING BY: _____	DATE _____	<input type="checkbox"/> A. P. C. D.
FINAL ACTION: <input type="checkbox"/> APPROVED <input type="checkbox"/> DENIED	DATE _____	<input type="checkbox"/> O. E. S.
	DATE _____	<input type="checkbox"/> _____
	DATE _____	<input type="checkbox"/> _____

CUP #

CONDITIONAL USE PERMIT

I.C. PLANNING & DEVELOPMENT SERVICES DEPT.
801 Main Street, El Centro, CA 92243 (760) 482-4236

- APPLICANT MUST COMPLETE ALL NUMBERED (black) SPACES - Please type or print -

1. PROPERTY OWNER'S NAME Apex Energy Solutions, LLC		EMAIL ADDRESS c/o Jurgheuberger@gmail.com	
2. MAILING ADDRESS (Street / P O Box, City, State) 604 Sutter St., Suite 250, Folsom, CA		ZIP CODE 95630	PHONE NUMBER 760-996-0313
3. APPLICANT'S NAME Northstar 1 SES (Project Name)		EMAIL ADDRESS NA	
4. MAILING ADDRESS (Street / P O Box, City, State) same		ZIP CODE _____	PHONE NUMBER _____
4. ENGINEER'S NAME NA	CA. LICENSE NO. _____	EMAIL ADDRESS _____	
5. MAILING ADDRESS (Street / P O Box, City, State) NA		ZIP CODE _____	PHONE NUMBER _____

6. ASSESSOR'S PARCEL NO. 003-110-005 & 003-110-007	SIZE OF PROPERTY (in acres or square foot) 112 Ac and 176 ac	ZONING (existing) S-2
7. PROPERTY (site) ADDRESS pending		
8. GENERAL LOCATION (i.e. city, town, cross street) see attached data (northwest of Niland)		
9. LEGAL DESCRIPTION <u>See attached title report</u>		

PLEASE PROVIDE CLEAR & CONCISE INFORMATION (ATTACH SEPARATE SHEET IF NEEDED)

10. DESCRIBE PROPOSED USE OF PROPERTY (list and describe in detail) <u>construct a water well (1.5- 5 ac. ft./yr) to develop a solar power project with a battery storage system at approximately 50 MW and 75 MW storage</u>	
11. DESCRIBE CURRENT USE OF PROPERTY	<u>vacant</u>
12. DESCRIBE PROPOSED SEWER SYSTEM	<u>NA</u>
13. DESCRIBE PROPOSED WATER SYSTEM	<u>NA</u>
14. DESCRIBE PROPOSED FIRE PROTECTION SYSTEM	<u>meet county fire standards</u>
15. IS PROPOSED USE A BUSINESS? <input type="checkbox"/> Yes <input type="checkbox"/> No	IF YES, HOW MANY EMPLOYEES WILL BE AT THIS SITE? construction approx. 150, operations about 1-2

I / WE THE LEGAL OWNER (S) OF THE ABOVE PROPERTY CERTIFY THAT THE INFORMATION SHOWN OR STATED HEREIN IS TRUE AND CORRECT.

<u>Ziad Alaywan</u>	<u>March 20, 2023</u>
Print Name	Date
	_____
Signature	_____
_____	_____
Print Name	Date
_____	_____
Signature	_____

REQUIRED SUPPORT DOCUMENTS

- A. SITE PLAN
- B. FEE _____
- C. OTHER _____
- D. OTHER _____

APPLICATION RECEIVED BY: _____	DATE _____	REVIEW / APPROVAL BY OTHER DEPT'S required.
APPLICATION DEEMED COMPLETE BY: _____	DATE _____	<input type="checkbox"/> P. W.
APPLICATION REJECTED BY: _____	DATE _____	<input type="checkbox"/> E. H. S.
TENTATIVE HEARING BY: _____	DATE _____	<input type="checkbox"/> A. P. C. D.
FINAL ACTION: <input type="checkbox"/> APPROVED <input type="checkbox"/> DENIED	DATE _____	<input type="checkbox"/> O. E. S.
	DATE _____	<input type="checkbox"/> _____
	DATE _____	<input type="checkbox"/> _____

CUP #

North Star 1 SES (Apex Energy Solutions)



Imperial County Planning & Development Services Planning / Building / Parks & Recreation

Jim Minnick
DIRECTOR

NOTICE TO APPLICANT

SUBJECT: PAYMENT OF FEES

Dear Applicant:

Pursuant to County Codified Ordinance Division 9, Chapter 1, Section 90901.02, all Land Use Applications must be submitted with their appropriate application fee. Failure to comply will cause application to be rejected.

Please note that once the Department application is received and accepted, a "time track" billing will commence immediately. Therefore, should you decide to cancel or withdraw your project at any time, the amount of time incurred against your project will be billed and deducted from your payment. As a consequence, if you request a refund pursuant to County Ordinance, your refund, if any, will be the actual amount paid minus all costs incurred against the project.

Please note there will be no exceptions to this policy. Thank you for your attention.

Sincerely yours,

Jim Minnick, Director
Planning & Development Services

RECEIVED BY: _____

DATE: _____

3/27/2023

North Star ISES (Apex Energy Solutions)

IMPERIAL COUNTY PLANNING & DEVELOPMENT SERVICES GENERAL INDEMNIFICATION AGREEMENT

As part of this application, applicant and real party in interest, if different, agree to defend, indemnify, hold harmless, and release the County of Imperial ("County"), its agents, officers, attorneys, and employees (including consultants) from any claim, action, or proceeding brought against any of them, the purpose of which is to attack, set aside, void, or annul the approval of this application or adoption of the environmental document which accompanies it. This indemnification obligation shall include, but not be limited to, damages, costs, expenses, attorney fees, or expert witness fees that may be asserted by any person or entity, including the applicant, arising out of or in connection with the approval of this application, whether or not there is concurrent negligence on the part of the County, its agents, officers, attorneys, or employees (including consultants).

If any claim, action, or proceeding is brought against the County, its agents, officers, attorneys, or employees (including consultants), to attack, set aside, void, or annul the approval of the application or adoption of the environmental document which accompanies it, then the following procedures shall apply:

1. The Planning Director shall promptly notify the County Board of Supervisors of any claim, action or proceeding brought by an applicant challenging the County's action. The County, its agents, attorneys and employees (including consultants) shall fully cooperate in the defense of that action.
2. The County shall have the final determination on how to best defend the case and will consult with applicant regularly regarding status and the plan for defense. The County will also consult and discuss with applicant the counsel to be used by County to defend it, either with in-house counsel, or by retaining outside counsel provided that the County shall have the final decision on the counsel retained to defend it. Applicant shall be fully responsible for all costs incurred. Applicant shall be entitled to provide his or her own counsel to defend the case, and said independent counsel shall work with County Counsel to provide a joint defense.

Executed at Folsom California on March 27, 2023

APPLICANT

REAL PARTY IN INTEREST

(If different from Applicant)

Name: Ziad Alaywan
By *Ziad Alaywan*
Title Managing Member

Name _____
By _____
Title _____

Mailing Address:
604 Sutter St., Suite 250
Folsom, CA 95630

Mailing Address:

ACCEPTED/RECEIVED BY _____ Date _____

PROJECT ID NO _____ APN _____

S:\FORMS_LISTS\General Indemnification FORM 041516.doc

A.L.T.A./N.S.P.S. LAND TITLE SURVEY

PORTIONS OF SECTION 1, TOWNSHIP 10 SOUTH, RANGE 13 EAST, IN AN UNINCORPORATED AREA OF THE COUNTY OF IMPERIAL, STATE OF CALIFORNIA

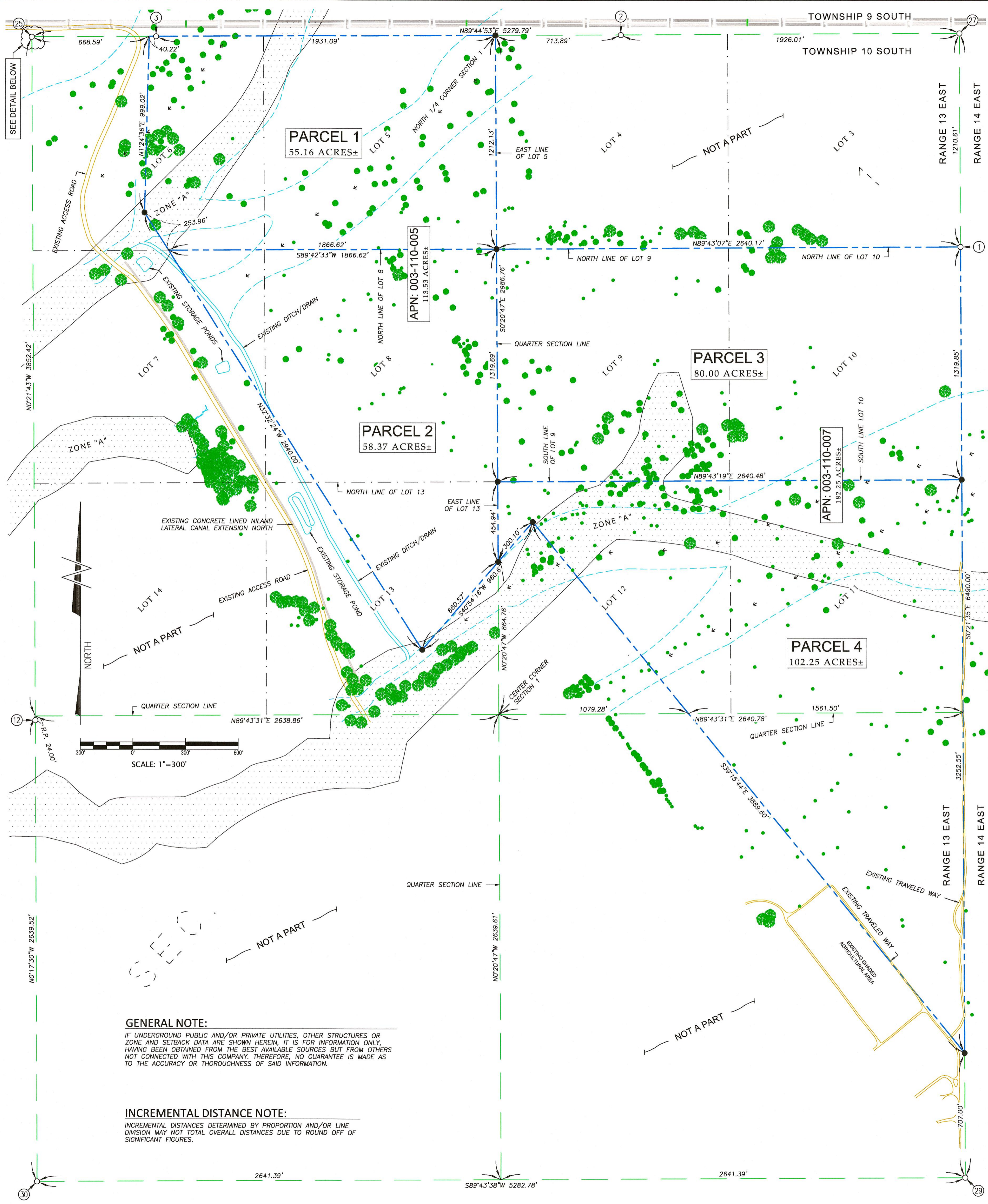

BASIS OF BEARINGS
 THE BASIS OF BEARINGS IS NORTH 12°20'53" EAST 45429.33' WHICH IS THE BEARING FROM MONUMENT NO. 30 WHICH IS THE SOUTHWEST CORNER OF SECTION 1 IN T.10S., R.13E., S.B.M. AND CALIFORNIA REAL TIME NETWORK (CRTN) STATION: REDISLANDMCS2005/P507
 REDISLANDMCS2005/P507
 N: 2016983.537 E: 6756708.262
 S.W. CORNER SECTION 1
 N: 2061361.940 E: 6766423.247
 CALIFORNIA NAD83 COORDINATE SYSTEM, ZONE 6

ZONING:
 APN: 003-110-005 IS SUBJECT TO ZONE S-2G
 APN: 003-110-007 IS SUBJECT TO ZONE S-2G

SURVEYOR'S STATEMENT
 THIS IS TO CERTIFY TO 1) STAVROS KONDISILIS AND HEE-JIN KANG, HUSBAND AND WIFE 2) Z-GLOBAL, INC. 3) AND CHICAGO TITLE INSURANCE COMPANY THAT THIS MAP OR PLAT AND SURVEY ON WHICH IT IS BASED WERE MADE IN ACCORDANCE WITH "MINIMUM STANDARD DETAIL REQUIREMENTS FOR ALTA/NSPS LAND TITLE SURVEYS" JOINTLY ESTABLISHED AND ADOPTED BY ALTA AND NSPS IN FEBRUARY 23, 2021, AND PURSUANT TO THE ACCURACY STANDARDS ADOPTED BY ALTA AND NSPS AND IN EFFECT ON THE DATE OF THIS CERTIFICATION. THE UNDERSIGNED HEREBY CERTIFIES THAT THE POSITIONAL UNCERTAINTIES RESULTING FROM THE SURVEY MEASUREMENTS MADE ON THE SURVEY DO NOT EXCEED THE ALLOWABLE POSITIONAL TOLERANCE. THE UNDERSIGNED FURTHER CERTIFIES THAT OPTIONAL ITEM NUMBERS 1, 2, 3, 7(G), 8, 11, 18, AND 19 FROM TABLE A, OPTIONAL SURVEY RESPONSIBILITIES AND SPECIFICATIONS, OF THE MINIMUM STANDARD DETAIL REQUIREMENTS FOR ALTA/NSPS LAND TITLE SURVEYS ARE INCLUDED IN THIS SURVEY. THE UNDERSIGNED ADDITIONALLY CERTIFIES THAT (a) THIS SURVEY WAS MADE ON THE GROUND UNDER MY SUPERVISION; (b) I HAVE RECEIVED AND EXAMINED A COPY OF THE PRELIMINARY TITLE REPORT DATED AS OF OCTOBER 28, 2021 BY CHICAGO TITLE INSURANCE COMPANY AS WELL AS A COPY OF EACH INSTRUMENT LISTED THEREIN, AND THE SUBJECT LAND AND EACH TRACT OR PARCEL

THEREOF DESCRIBED IN THIS SURVEY IS THE SAME LAND AS DESCRIBED IN THE TITLE COMMITMENT; (c) IF THE SUBJECT LAND CONSISTS OF TWO OR MORE TRACTS OR PARCELS HAVING COMMON BOUNDARIES, THOSE TRACTS AND PARCELS ARE CONTIGUOUS ALONG THE COMMON BOUNDARIES; (d) THE SUBJECT LAND AND EACH TRACT OR PARCEL THEREOF HAS A TAX MAP DESIGNATION SEPARATE AND DISTINCT FROM THAT OF ANY OTHER LAND AND THE SUBJECT LAND AND EACH TRACT OR PARCEL THEREOF IS A SEPARATE, LEGALLY SUBDIVIDED PARCEL; (e) THIS SURVEY CORRECTLY SHOWS ALL MATTERS OF RECORD (AND TO THE EXTENT THEY CAN BE LOCATED, THEIR LOCATION AND DIMENSIONS) OF WHICH I HAVE BEEN ADVISED AFFECTING THE SUBJECT LAND AND ACCORDING TO THE LEGAL DESCRIPTION OF SUCH MATTERS (WITH INSTRUMENT, BOOK AND PAGE NUMBER INDICATED); (f) A PORTION OF THE SUBJECT LAND IS LOCATED IN A 100-YEAR FLOOD PLAIN OR IN AN IDENTIFIED "FLOOD PRONE AREA", AS DEFINED PURSUANT TO THE FLOOD DISASTER PROTECTION ACT OF 1973 AS AMENDED, AS REFLECTED BY FLOOD INSURANCE RATE MAP PANEL NO. 60205C425C DATED SEPTEMBER 26, 2008. SUBJECT PROPERTY IS LOCATED WITHIN ZONE "X"; (g) TO THE BEST OF MY KNOWLEDGE, THIS SURVEY SHOWS THE RELATION OF OTHER IMPROVEMENTS TO EASEMENTS AND SETBACK LINES.

TAYLOR J. PREECE, P.L.S. NO. 9436
 DATE: 6-7-2022

PROFESSIONAL LAND SURVEYOR
 TAYLOR J. PREECE
 LS 9436
 STATE OF CALIFORNIA

PROPERTY LOCATION
 PROPERTY LOCATED IN SECTION 1 IN TOWNSHIP 10 SOUTH, RANGE 13 EAST, S.B.M. IN THE COUNTY OF IMPERIAL, STATE OF CALIFORNIA.

LEGAL DESCRIPTION
PARCEL 1
 LOT 5, AND THAT PORTION OF LOT 6, SECTION 1, TOWNSHIP 10 SOUTH, RANGE 13 EAST, S.B.M., IN AN UNINCORPORATED AREA OF THE COUNTY OF IMPERIAL, STATE OF CALIFORNIA, ACCORDING TO THE OFFICIAL PLAT THEREOF, LYING EAST OF THE FOLLOWING DESCRIBED LINE:
 BEGINNING AT A POINT 668.59 FEET EAST OF THE NORTHWEST CORNER OF SAID SECTION 1; THENCE SOUTH 1°46'20" WEST, 999.02 FEET; THENCE SOUTH 32°10'40" EAST, TO THE SOUTH LINE OF SAID LOT 6.

EXCEPTING THEREFROM ANY PORTION THEREOF INCLUDED WITHIN THE RIGHT OF WAY FOR THAT CERTAIN DITCH, LOCATED ALONG A PORTION OF THE SOUTHWESTERLY LINE OF SAID LAND, SAID SOUTHWESTERLY LINE HAVING A BEARING OF SOUTH 32°10'40" EAST, A DISTANCE OF 2940 FEET.

NOTE:
 A RECORD OF SURVEY HAS BEEN PREPARED FOR THIS SITE AND SUBMITTED TO IMPERIAL COUNTY PUBLIC WORKS. THE BOUNDARY SHOWN HEREON IS SUBJECT TO REVIEW AND APPROVAL OF THE RECORD OF SURVEY BY THE COUNTY SURVEYOR.

EXCEPTING THEREFROM ANY PORTION THEREOF INCLUDED WITHIN THE RIGHT OF WAY FOR THAT CERTAIN DRAIN DITCH LOCATED ALONG A PORTION OF THE SOUTHWESTERLY LINE OF SAID LAND, SAID SOUTHWESTERLY LINE HAVING A BEARING OF SOUTH 32°10'40" EAST, A DISTANCE OF 2940 FEET.

ALSO EXCEPTING THEREFROM ANY AND ALL REMAINING MINERAL RIGHTS, TOGETHER WITH THE RIGHT OF ENTRY TO REMOVE THE SAME, AS RESERVED BY N.R.L.L., INC., A CALIFORNIA CORPORATION IN DEED RECORDED MARCH 19, 2004 AS DOCUMENT NO. 2004-007986 IN BOOK 2288, PAGE 861 OF OFFICIAL RECORDS.

CURRENT VESTED IN:
 STAVROS KONDISILIS AND HEE-JIN KANG, HUSBAND AND WIFE AS JOINT TENANTS, AS TO PARCELS 1 AND 2, AND STAVROS KONDISILIS, A MARRIED MAN AS HIS SOLE AND SEPARATE PROPERTY, AS TO PARCELS 3 AND 4, SUBJECT TO ITEMS 8 AND 9 OF PRELIMINARY TITLE REPORT No. 7102118841-SB

PARCEL 2
 THOSE PORTIONS OF LOTS 7, 8 AND 13 OF SECTION 1, TOWNSHIP 10 SOUTH, RANGE 13 EAST, S.B.M., IN AN UNINCORPORATED AREA OF THE COUNTY OF IMPERIAL, STATE OF CALIFORNIA, ACCORDING TO THE OFFICIAL PLAT THEREOF, LYING NORTH AND EAST OF THE FOLLOWING DESCRIBED LINE:
 BEGINNING AT A POINT 668.59 FEET EAST OF THE NORTHWEST CORNER OF SAID SECTION 1; THENCE SOUTH 1°46'20" WEST, 999.02 FEET; THENCE SOUTH 32°10'40" EAST, 2940 FEET; THENCE NORTH 41°16' EAST, 960.67 FEET; THENCE SOUTH 38°54' EAST, 3894.05 FEET TO THE EAST LINE OF SAID SECTION 1.

ALSO EXCEPTING THEREFROM ANY AND ALL REMAINING MINERAL RIGHTS, TOGETHER WITH THE RIGHT OF ENTRY TO REMOVE THE SAME, AS RESERVED BY N.R.L.L., INC., A CALIFORNIA CORPORATION IN DEED RECORDED MARCH 19, 2004 AS DOCUMENT NO. 2004-007986 IN BOOK 2288, PAGE 861 OF OFFICIAL RECORDS.

- CORNER DESCRIPTIONS**
- SOUTHEAST CORNER LOT 3, SECTION 1 (T.10S., R.13E.) FOUND 5" DIAMETER CONCRETE CYLINDER WITH DISC STAMPED, "LS 5397, 1987", SET BY THE IMPERIAL IRRIGATION DISTRICT, UP 0.75' ABOVE DESERT SURFACE. REFERENCE ROS 8-31.
 - SOUTH 1/4 CORNER, SECTION 36 (T.9S., R.13E.) FOUND 1" IRON PIPE WITH BRASS CAP, BENT OVER, LAYING ON SIDE. OBSERVED VERTICAL PORTION OF IRON PIPE. REFERENCE ROS 8-31.
 - UNKNOWN CORNER FOUND 1.5" IRON PIPE WITH PLASTIC PLUG MARKED, "LS 5397", UP 0.15' ABOVE DESERT SURFACE. NO RECORD INFORMATION FOUND.
 - R.P. 24' SOUTH OF WEST 1/4 CORNER, SECTION 1 (T.10S., R.13E.) FOUND CONCRETE CYLINDER, DOWN 0.50' BELOW DESERT SURFACE. ACCEPTED AS TRUE POSITION AS SHOWN ON ROS 8-31 AND IMPERIAL COUNTY SURVEY TIE CARD.
 - NORTHWEST CORNER, SECTION 1 (T.10S., R.13E.) FOUND CONCRETE CYLINDER, UP 0.50' ABOVE DESERT SURFACE. ACCEPTED AS TRUE POSITION AS SHOWN ON ROS 8-31.
 - NORTHEAST CORNER, SECTION 1 (T.10S., R.13E.) FOUND 2" IRON PIPE WITH 3" DIAMETER GLO BRASS CAP ON TOP, UP 1.1' ABOVE DESERT SURFACE. ACCEPTED AS TRUE POSITION AS SHOWN ON ROS 8-31.
 - SOUTHEAST CORNER, SECTION 1 (T.10S., R.13E.) FOUND 2" IRON PIPE WITH 3" DIAMETER GLO BRASS CAP ON TOP, DOWN 1.5' BELOW DESERT SURFACE. LOCATED 1" NORTH OF GUARD POST. ACCEPTED AS TRUE POSITION AS SHOWN ON ROS 8-31 AND IMPERIAL COUNTY SURVEY TIE CARD.
 - SOUTHWEST CORNER, SECTION 1 (T.10S., R.13E.) FOUND 1.5" IRON PIPE WITH TAG STAMPED, "LS 5926", DOWN 0.4' BELOW DESERT SURFACE. ACCEPTED AS TRUE POSITION AS SHOWN ON ROS 22-76.

SCHEDULE B ITEMS FROM PRELIMINARY TITLE REPORT No. 7102118841-SB DATED OCTOBER 28, 2021

⚠ TAXES AND ASSESSMENTS LEVIED BY THE IMPERIAL IRRIGATION DISTRICT, IF ANY.

⚠ WATER RIGHTS, CLAIMS OR TITLE TO WATER, WHETHER OR NOT DISCLOSED BY THE PUBLIC RECORDS.

⚠ ANY RIGHTS INCIDENTAL TO THE OWNERSHIP AND DEVELOPMENT OF THE MINERAL INTEREST EXCEPTED OR RESERVED IN THE DOCUMENT:
 RECORDING DATE: MARCH 19, 2004
 RECORDING NO.: 2004-007986 IN BOOK 2288, PAGE 861 OF OFFICIAL RECORD
 AFFECTS: PARCELS 1 AND 2

⚠ THE EFFECT OF A DEED:
 FROM: LIA KONDISILIS, SPOUSE OF GRANTEE
 TO: STAVROS KONDISILIS, A MARRIED MAN AS HIS SOLE AND SEPARATE PROPERTY
 DATED: FEBRUARY 9, 2004
 RECORDING DATE: NOVEMBER 18, 2008
 RECORDING NO.: 2008-032879 OF OFFICIAL RECORDS
 AFFECTS: PARCELS 3 AND 4

ANY DEFECT OR INVALIDITY OF THE TITLE TO THE ESTATE OR INTEREST OF THE GRANTEE HEREIN ARISING OUT OF OR OCCASIONED BY THE EXECUTION OF THAT CERTAIN ABOVE REFERENCED DEED.

PARCEL 3
 LOT 9 AND 10, SECTION 1, TOWNSHIP 10 SOUTH, RANGE 13 EAST, S.B.M., IN AN UNINCORPORATED AREA OF THE COUNTY OF IMPERIAL, STATE OF CALIFORNIA, ACCORDING TO THE OFFICIAL PLAT THEREOF, LYING NORTH AND EAST OF THE FOLLOWING DESCRIBED LINE:
 BEGINNING AT A POINT 668.59 FEET EAST OF THE NORTHWEST CORNER OF SAID SECTION 1; THENCE SOUTH 1°46'20" WEST, 999.02 FEET; THENCE SOUTH 32°10'40" EAST, 2940 FEET; THENCE NORTH 41°16' EAST, 960.67 FEET; THENCE SOUTH 38°54' EAST, 3894.05 FEET TO THE EAST LINE OF SAID SECTION 1.

PARCEL 4
 LOT 11 AND THOSE PORTIONS OF LOT 12, AND THE SOUTHEAST QUARTER OF SECTION 1, TOWNSHIP 10 SOUTH, RANGE 13 EAST, S.B.M., IN AN UNINCORPORATED AREA OF THE COUNTY OF IMPERIAL, STATE OF CALIFORNIA, ACCORDING TO THE OFFICIAL PLAT THEREOF, LYING NORTH AND EAST OF THE FOLLOWING DESCRIBED LINE:
 BEGINNING AT A POINT 668.59 FEET EAST OF THE NORTHWEST CORNER OF SAID SECTION 1; THENCE SOUTH 1°46'20" WEST, 999.02 FEET; THENCE SOUTH 32°10'40" EAST, 2940 FEET; THENCE NORTH 41°16' EAST, 960.67 FEET; THENCE SOUTH 38°54' EAST, 3894.05 FEET TO THE EAST LINE OF SAID SECTION 1.

FOR THE PURPOSE OF TITLE INSURANCE, THIS COMPANY REQUIRES THAT AN AFFIDAVIT EXECUTED BY THE GRANTEE ABOVE AND ACKNOWLEDGED BY A NOTARY, KNOWN TO THE TITLE COMPANY, BE SUBMITTED TO THIS OFFICE FOR REVIEW AND APPROVAL, IN ORDER FOR THIS COMPANY TO SHOW TITLE VESTED IN THE ABOVE NAMED GRANTEE. SAID AFFIDAVIT WILL BE PROVIDED BY THIS COMPANY AND, UPON REQUEST, CAN BE IN SPANISH.

TITLE DATA NOTE:
 AS TO THE TITLE MATTERS SHOWN AND NOTED HEREIN, PRECISION ENGINEERING & SURVEYING, INC. AND TAYLOR J. PREECE HAVE RELIED SOLELY UPON INFORMATION PROVIDED BY CHICAGO TITLE INSURANCE COMPANY IN PRELIMINARY TITLE REPORT ORDER No. 7102118841-SB DATED OCTOBER 28, 2021. OTHER CONDITIONS AFFECTING TITLE SUCH AS TRUST DEEDS, TAXES, ETC. ARE CONTAINED IN SAID PRELIMINARY TITLE REPORT AND INCORPORATED HEREIN BY REFERENCE. PRECISION ENGINEERING & SURVEYING, INC. MAKES NO STATEMENTS AS TO THE ACCURACY OR COMPLETENESS OF THE SUBJECT PRELIMINARY TITLE REPORTS.

PROPERTY NOTE:
 NO RECENT EARTH MOVING WORK, BUILDING CONSTRUCTION OR BUILDING ADDITIONS OBSERVED.

PROFESSIONAL LIABILITY INSURANCE
 PROFESSIONAL LIABILITY INSURANCE POLICY OBTAINED BY THE SURVEYOR IN THE MINIMUM AMOUNT OF \$1,000,000 TO BE IN EFFECT THROUGHOUT THE CONTRACT TERM. CERTIFICATE OF INSURANCE TO BE FURNISHED UPON REQUEST.

- LEGEND**
- INDICATES FEMA ZONE "A"
 - INDICATES PARCEL BOUNDARY
 - INDICATES SECTION LINE
 - INDICATES LOT LINES
 - INDICATES WATERSHED OUTLINE
 - EXISTING OVERHEAD POWER LINE
 - EXISTING UNPAVED ROAD/TRAVELED WAY
 - INDICATES EXISTING BRUSH/TREES
 - FOUND MONUMENT AS DESCRIBED
 - SET 1.5" IRON PIPE WITH TAG STAMPED, "T. PREECE PLS 9436"
 - CORNER DESCRIPTION REFERENCE NUMBER AS DESCRIBED ON THIS SHEET
 - INDICATES WATER FLOW DIRECTION

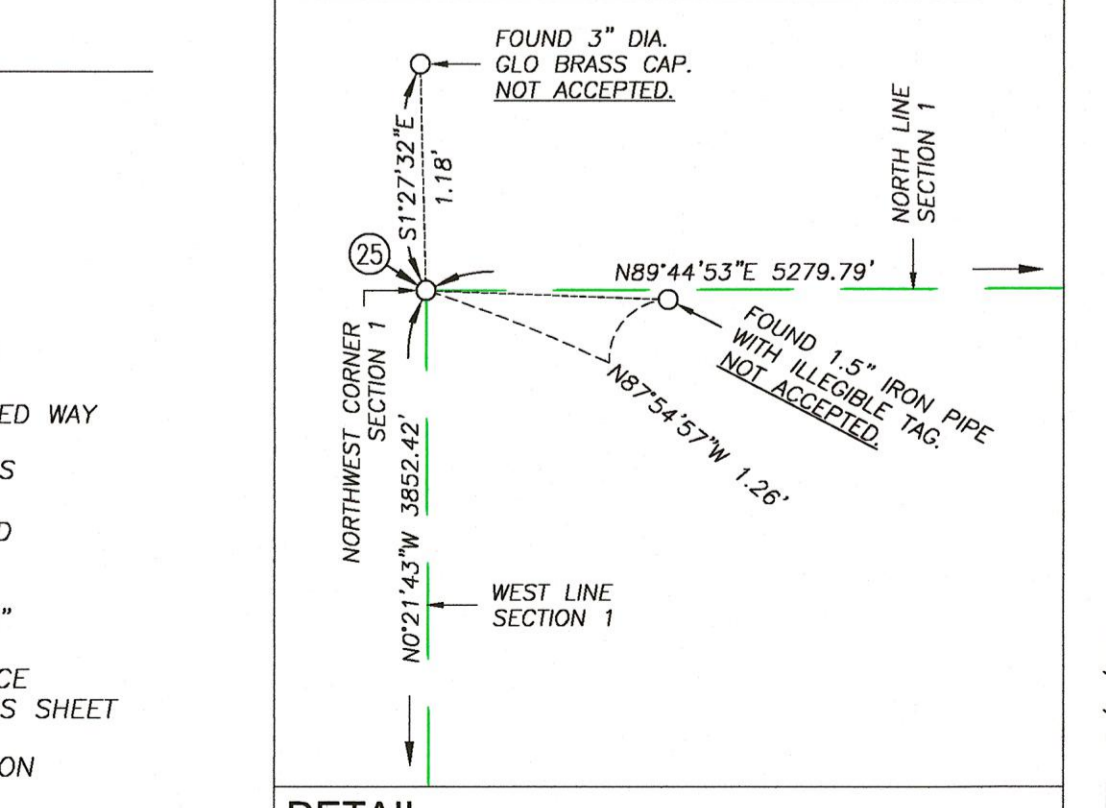

PRINTED: 6/7/2022

A.L.T.A./N.S.P.S.: PORTIONS SECTION 1

SHEET TITLE: TITLE/MAP SHEET
 LOCATION: SECTION 1 T.10S., R.13E. S.B.M.
 CLIENT: Z-GLOBAL, INC.

SHEET No. **1**

OF 1 SHEETS

DRAWN BY: A.D.
 DATE: 05/31/2022

REVISED:
 JOB No. 22-123

Precision Engineering & Surveying, Inc.
 P.O. Box 2216 Telephone (760) 353-2684
 El Centro, CA 92544 (760) 353-2684
 799 E. Hill Avenue Fax (760) 353-2686
 El Centro, CA 92543

GENERAL NOTE:
 IF UNDERGROUND PUBLIC AND/OR PRIVATE UTILITIES, OTHER STRUCTURES OR ZONE AND SETBACK DATA ARE SHOWN HEREIN, IT IS FOR INFORMATION ONLY, HAVING BEEN OBTAINED FROM THE BEST AVAILABLE SOURCES BUT FROM OTHERS NOT CONNECTED WITH THIS COMPANY. THEREFORE, NO GUARANTEE IS MADE AS TO THE ACCURACY OR THOROUGHNESS OF SAID INFORMATION.

INCREMENTAL DISTANCE NOTE:
 INCREMENTAL DISTANCES DETERMINED BY PROPORTION AND/OR LINE DIVISION MAY NOT TOTAL OVERALL DISTANCES DUE TO ROUND OFF OF SIGNIFICANT FIGURES.

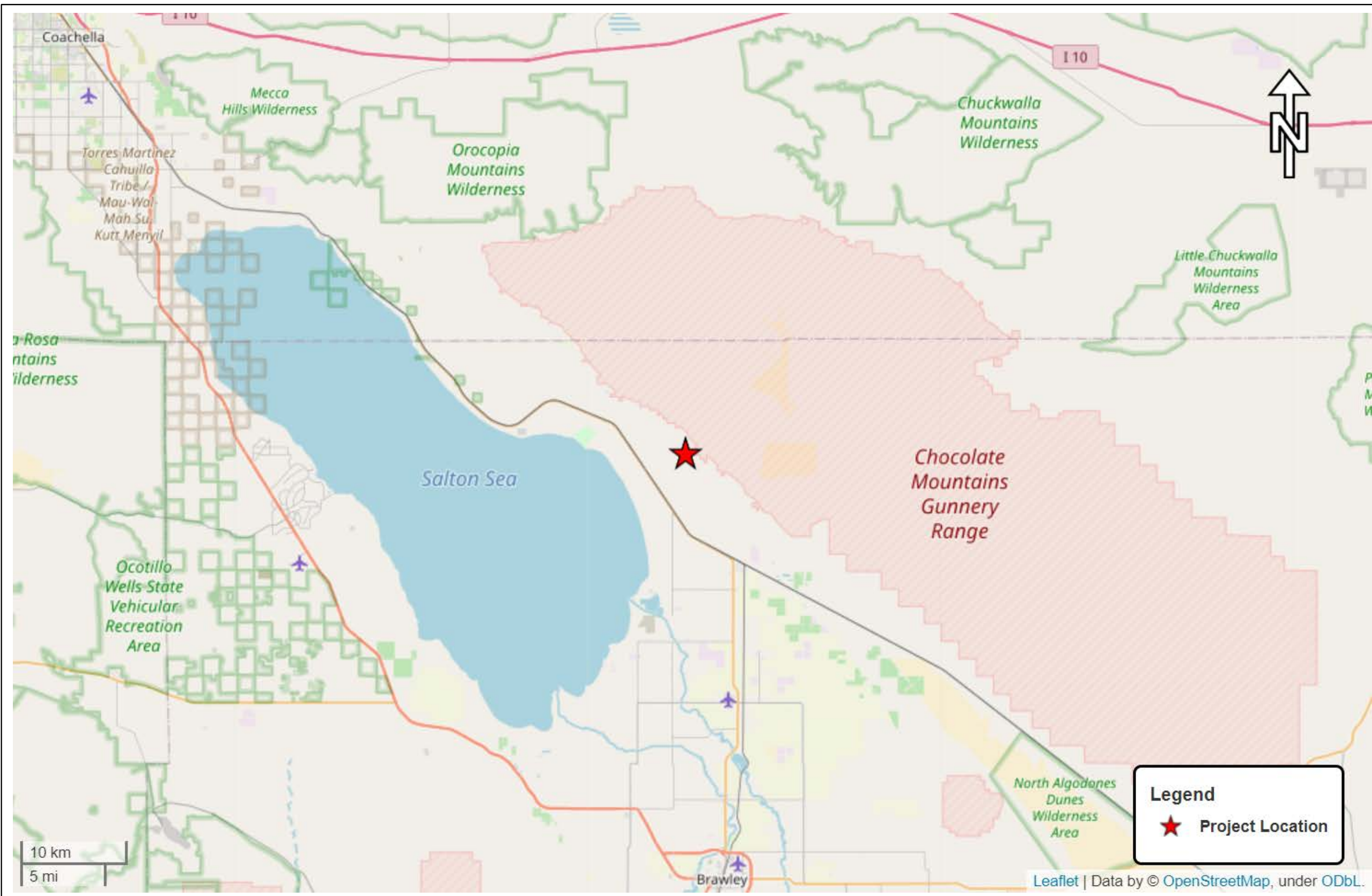

Legend
 ★ Project Location

Map Date: 5/12/2022
 Photo (or Base) Source: ECORP Consulting, Inc.



Figure 1. Project Regional Map

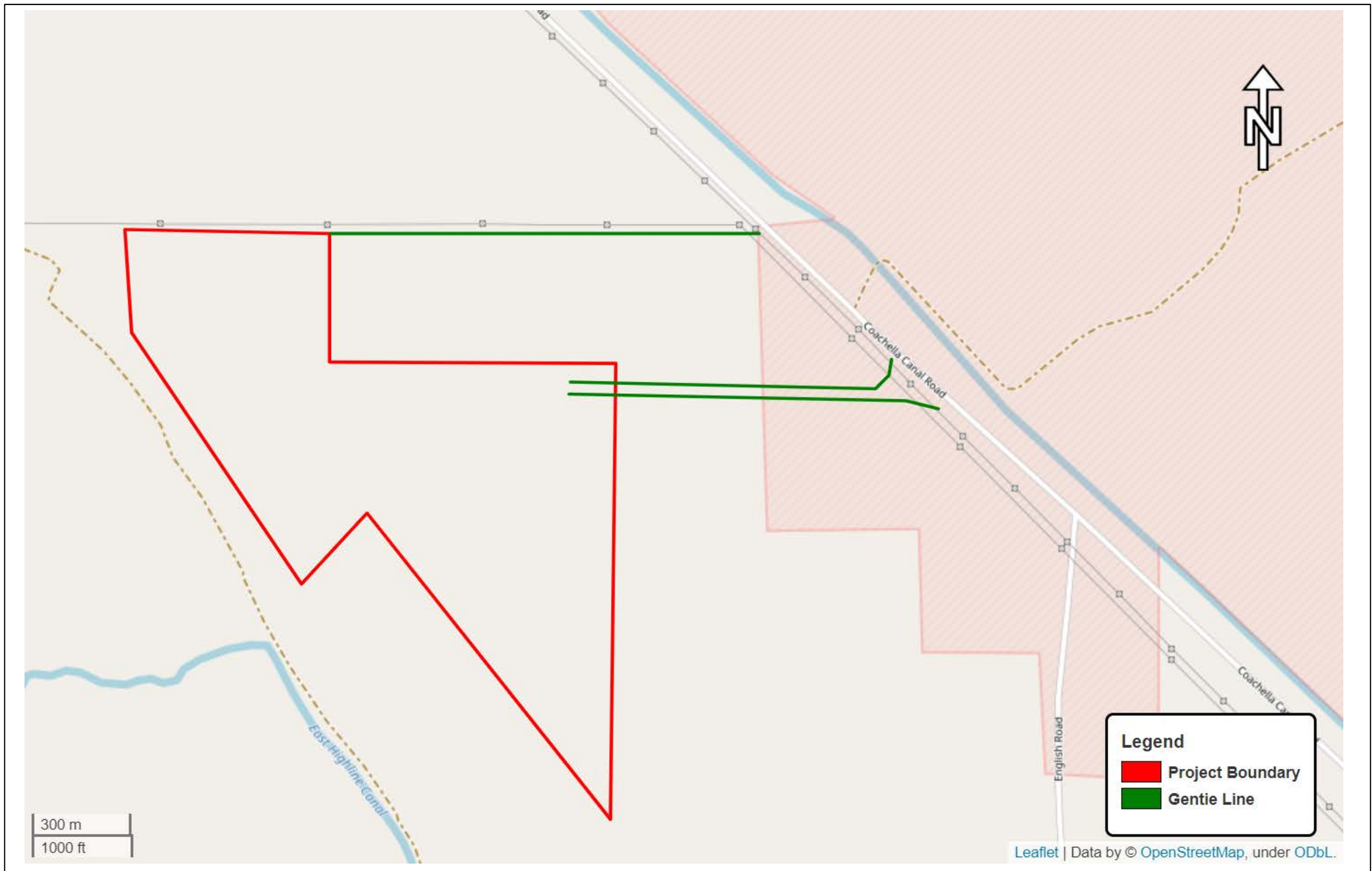

Map Date: 5/12/2022
 Photo (or Base) Source: ECORP Consulting, Inc.

Figure 2. Project Vicinity Map

Common Outdoor Activities	Noise Level (dBA)	Common Indoor Activities
<u>Jet Fly-over at 300m (1000 ft)</u>	110	<u>Rock Band</u>
<u>Gas Lawn Mower at 1 m (3 ft)</u>	100	
<u>Diesel Truck at 15 m (50 ft), at 80 km (50 mph)</u>	90	<u>Food Blender at 1 m (3 ft)</u>
<u>Noisy Urban Area, Daytime</u>	80	<u>Garbage Disposal at 1 m (3 ft)</u>
<u>Gas Lawn Mower, 30 m (100 ft)</u>	70	<u>Vacuum Cleaner at 3 m (10 ft)</u>
<u>Commercial Area</u>		<u>Normal Speech at 1 m (3 ft)</u>
<u>Heavy Traffic at 90 m (300 ft)</u>	60	<u>Large Business Office</u>
<u>Quiet Urban Daytime</u>	50	<u>Dishwasher Next Room</u>
<u>Quiet Urban Nighttime</u>	40	<u>Theater, Large Conference Room (Background)</u>
<u>Quiet Suburban Nighttime</u>		<u>Library</u>
<u>Quiet Rural Nighttime</u>	30	<u>Bedroom at Night,</u>
	20	<u>Concert Hall (Background)</u>
	10	<u>Broadcast/Recording Studio</u>
<u>Lowest Threshold of Human Hearing</u>	0	<u>Lowest Threshold of Human Hearing</u>

Source: California Department of Transportation (Caltrans) 2020a

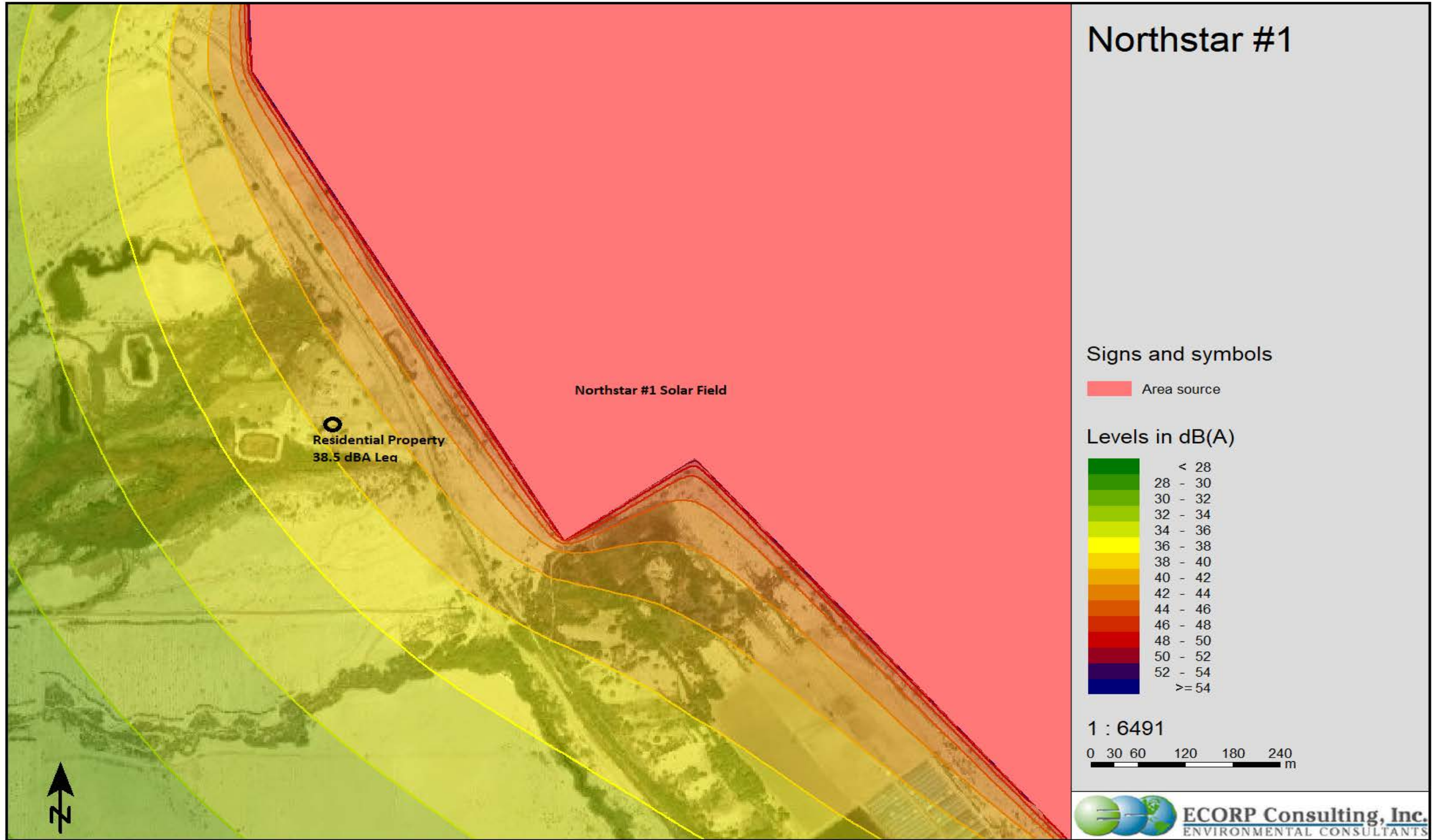

Map Date: 6/3/2022
 Photo (or Base) Source: SoundPLAN 5.1

Figure 4. Project Onsite Noise Source Propagation

Phase I ESA Report

NorthStar 1 Solar Site East Highline Canal & Niland Lateral 6 Niland, California

Prepared for:

Apex Energy Solutions, LLC
750 Main Street
El Centro, CA 92243



Prepared by:



GS Lyon Consultants, Inc.
780 N. 4th Street
El Centro, CA 92243
(760) 337-1100

October 2022



Engineering And
Information Technology

October 14, 2022

Mr. Ziad Alaywan
Apex Energy Solutions, LLC
750 Main Street
El Centro, CA 92243

**Phase I Environmental Site Assessment Report
NorthStar 1 Solar Site
East Highline Canal & Niland Lateral 6
Niland, California
GSL Report No. GS2219**

Dear Mr. Alaywan:

We have performed a Phase I Environmental Site Assessment in general conformance with the scope and limitations of ASTM E1527-13 of the approximately 280-acre property located on the east side of the East Highline Canal north of the Niland Lateral 6 approximately 7 miles northwest of Niland, California. Any exceptions to, or deletions from, this practice are described in Section 1.4 of this report. **This assessment has revealed no evidence of recognized environmental conditions (REC's) in connection with the property.**

We declare that, to the best of our professional knowledge and belief, we meet the definition of *Environmental Professional* as defined in §312.10 of 40 CFR §312 and we have the specific qualifications based on education, training and experience to assess a property of the nature, history, and setting of the subject property. We have developed and performed all the appropriate inquiries in conformance with the standards and practices set forth in 40 CFR Part 312.

Attached is our report which describes the procedures used and results of the assessment. If you have any questions or require additional information, please do not hesitate to contact the undersigned at (760) 337-1100. We appreciate the opportunity to provide our professional review for this subject property.

Respectfully Submitted,
GS Lyon Consultants, Inc.

Peter E. LaBrucherie, PE
Consulting Engineer





Steven K. Williams, PG, CEG
Consulting Geologist



TABLE OF CONTENTS

1.0 INTRODUCTION 1

 1.1 Purpose 1

 1.2 Scope of Services 1

 1.3 Limitations 2

 1.4 Deviations or Data Gaps 2

 1.4.1 Data Failures 3

 1.4.2 Data Gaps..... 3

 1.5 Significant Assumptions 3

 1.6 User Reliance 4

2.0 SITE DESCRIPTION 5

 2.1 Site Location and Legal Description 5

 2.2 Current Property Use and Description 5

 2.3 Adjoining Property Use..... 5

 2.4 Physical Site Characteristics 5

3.0 USER PROVIDED INFORMATION 7

 3.1 Title Records 7

 3.2 Environmental Liens or Activity and Use Limitations 7

 3.3 Specialized Knowledge 8

 3.4 Commonly Known or Reasonable Ascertainable Information 8

 3.5 Valuation Reduction for Environmental Issues 8

 3.6 Owner, Property Manager, and Occupant Information..... 8

 3.7 Previous Reports and Other Provided Documentation 8

4.0 RECORDS REVIEW..... 9

 4.1 Regulatory Database Review 9

 4.1.1 Standard Environmental Record Sources 9

 4.1.2 Additional Environmental Record Sources 14

 4.2 Historical Use Records..... 16

 4.2.1 Title Records..... 16

 4.2.2 Sanborn Fire Insurance Maps 16

 4.2.3 Aerial Photographs..... 17

 4.2.4 Street Directories 17

 4.2.5 Historic Topographic Maps 18

 4.2.6 Historical Telephone Directories 18

 4.3 Historical Use Summary 18

 4.3.1 Summary of the Historical Use of Property..... 18

 4.3.2 Summary of the Historical Use of Adjacent Properties..... 18

5.0 SITE RECONNAISSANCE 19

 5.1 Methodology and Limiting Conditions 19

 5.2 General Site Setting..... 19

 5.3 Adjacent Properties 20

 5.4 Exterior and Interior Observations 20

 5.4.1 Hazardous Substances and Petroleum Products 20

 5.4.2 Storage Tanks..... 20

 5.4.3 Odors..... 20

5.4.4 Pools of Liquid..... 20

5.4.5 Drums and Containers..... 20

5.4.6 Unidentified Substance Containers..... 20

5.4.7 Suspect Polychlorinated Biphenyl (PCB) Containing Equipment..... 21

5.5 Interior Observations..... 21

5.6 Exterior Observations..... 21

5.6.1 Pits, Ponds, and Lagoons 21

5.6.2 Stained Soils or Pavement 21

5.6.3 Stressed Vegetation..... 21

5.6.4 Solid Waste 21

5.6.5 Wastewater..... 21

5.6.6 Wells 21

5.6.7 Septic Systems 21

5.7 Non-Scope Issues 21

5.7.1 Asbestos-Containing Building Materials..... 22

5.7.2 Lead-Based Paint 22

5.7.3 Radon 22

5.7.4 Wetlands 22

5.7.5 Agricultural Use..... 22

6.0 INTERVIEWS 23

6.1 Interview with Owner..... 23

6.2 Interview with the Site Manager 23

6.3 Interview with Occupants..... 23

6.4 Interview with Local Government Officials 23

7.0 EVALUATION..... 24

7.1 Summary of Findings..... 24

7.2 Conclusions 24

7.2.1 Recognized Environmental Conditions 24

7.2.2 Historical Recognized Environmental Conditions..... 24

7.2.3 Environmental Concerns and De Minimis Conditions 25

7.3 Recommendations 25

8.0 REFERENCES 26

APPENDICES

- Appendix A: Site Photographs
- Appendix B: Vicinity, Site, and Soils Maps
- Appendix C: Historical Aerial Photographs
- Appendix D: Historical Topographic Maps
- Appendix E: EDR Sanborn Fire Insurance Maps
- Appendix F: EDR Environmental Records Search Report
- Appendix G: Other Environmental Records Search Results
- Appendix H: EDR Street Directories
- Appendix I: User Questionnaire and EDR Environmental Lien and AUL Search
- Appendix J: Resumes of Environmental Professionals

1.0 INTRODUCTION

1.1 Purpose

GS Lyon Consultants, Inc. was retained by Apex Energy Solutions, LLC to conduct a Phase I Environmental Site Assessment (ESA) for the Property (herein referred to as the subject property or subject site in this Phase I ESA Report) as a prerequisite to property transaction (purchase, sale, refinance, etc.). The approximately 280-acre property is located on the northeast side of the East Highline Canal and Niland Lateral 6 approximately 7 miles northwest of Niland, California. See Plate 1 in Appendix B for a Vicinity Map of the subject property.

The purpose of this Phase I Environmental Site Assessment (ESA) is to identify, to the extent feasible, recognized environmental conditions (RECs) associated with past and present activities on the subject property or in the immediate subject property vicinity in general conformance to ASTM Standard E1527-13 “*Standard Practice for Environmental Site Assessments: Phase I Environmental Site Assessment Process*” that may affect future uses of the subject property.

This report is intended to satisfy the Phase I ESA portion of “*all appropriate inquiry*” into the previous ownership and uses of the subject property as defined under the Comprehensive Environmental Response, Compensation, and Liability Act (CERCLA) at Title 42 of the United States Code (U.S.C.) §9601(35)(B) and in accordance with 40 Code of Federal Regulations (CFR) Part 312, Standards and Practices for All Appropriate Inquiries; Final Rule (AAI Rule).

1.2 Scope of Services

The scope of work for this ESA is in general accordance with the requirements of ASTM Standard E1527-13. This assessment included:

- Reconnaissance of the subject property and adjacent properties
- Review user-provided information
- Interviews with persons with significant knowledge of the subject property
- Review of a regulatory database report provided by a third-party vendor
- Review readily-available historical sources (including but not limited to: aerial photographs, fire insurance maps, property tax files, recorded land title records, and topographical maps)
- Prepare report of findings

1.3 Limitations

No Phase I ESA can completely eliminate uncertainty regarding the potential for RECs in connection with a property. Conformance of this assessment with ASTM Standard E1527-13 is intended to reduce, but not eliminate uncertainty regarding the potential for RECs in connection with the Subject Property. While GS Lyon has made reasonable effort to discover and interpret available historical and current information on the property within the time available, the possibility of undiscovered contamination remains. Our assessment of the subject property and surrounding areas was conducted in accordance with ASTM guidelines and the *generally accepted environmental engineering standard of practice* which existed in Imperial County, California at the time that the report was prepared. No warranty, express or implied, is made.

GS Lyon Consultants, Inc. derived the data in this report primarily from visual inspections, examination of public records and information in the public domain, informal interviews with individuals, and readily available information about the subject property. The passage of time, manifestation of latent conditions or occurrence of future events may require further exploration of the subject property, analysis of the data, and reevaluation of the findings, observations, and conclusions expressed in this report.

The findings, observations, and conclusions expressed by GS Lyon Consultants in this report are not, and should not be considered, an opinion concerning the compliance of any past or present owner or operator of the subject property with any federal, state or local law or regulation.

This report should not be relied upon after **180 days** from the date of issuance, unless additional services are performed as defined in ASTM E1527-13 - Section 4.7.

1.4 Deviations or Data Gaps

ASTM Standard E1527-13 requires any significant data gaps, deviations, and deletions from the ASTM Standard to be identified and addressed in the Phase I ESA. A significant data gap would be one that affected the ability to identify a REC on the subject property or adjacent properties.

Through the course of this assessment, *data failures* or *data gaps* may have been encountered. These failures or gaps, if any, are discussed below. The following provides the opinion of the Environmental Professional as to the significance of the data gaps in terms of defining *recognized environmental conditions* at the subject property. Data failures may or may not be significant data gaps, and the discussion also provides information pertaining to whether the data failures resulted in significant data gaps.

1.4.1 Data Failures

Data failure is a failure to achieve the historical (property use) research objectives specified in the ASTM Standard Practice even after reviewing the eight standard historical sources that are reasonably ascertainable and likely to be useful. Data failure is one type of data gap. No *data failures* were encountered during this investigation.

1.4.2 Data Gaps

A *data gap* is a lack of or inability to obtain information required by the ASTM Standard Practice, despite good faith efforts by the Environmental Professional (EP) to gather such information. This could include any component of the Practice, e.g., standard environmental records, interviews, or a complete reconnaissance. A data gap by itself is not inherently significant, but if other information and/or the EP's experience raises reasonable concerns about the gap, it may be judged to be significant.

Due to the location of the subject property, Sanborn Fire Insurance maps were not available for the subject property. Because there is no historical data or physical indications that the property has ever been developed or occupied by a business that would have produced hazardous materials, the lack of Sanborn Fire Insurance maps is not considered a significant data gap.

Aerial photographs and other historical records were not available at 5 year intervals as required under the ASTM E1527-13 standard. This resulted in a data gap for years that records were not available regarding the area of the subject property. However, based upon other historical information reviewed, the subject property has been vacant desert land that has been used sporadically for mining of sand and clay. Therefore, this data gap is not considered to be significant.

Interviews with past owners, operators and occupants were not reasonably ascertainable and thus constitute a data gap. Based on information obtained from other historical sources (as discussed in Section 3.0), this data gap is not expected to alter the findings of this assessment.

1.5 Significant Assumptions

In preparing this report, GS Lyon Consultants, Inc. has relied upon and presumed accurate certain information (or the absence thereof) about the subject property and adjacent properties by governmental officials and agencies, the Client, and others identified herein. Except as otherwise stated in the report, GS Lyon Consultants has not attempted to verify the accuracy or completeness of any such information.

1.6 User Reliance

This report has been prepared on behalf of and for the exclusive use of Apex Energy Solutions, LLC for the particular subject property identified in this report, and is subject to and issued in connection with the referenced Agreement and the provisions thereof. This report should not be relied upon by any party other than the client, its legal counsel, and financial institution without the express permission of GS Lyon Consultants, Inc. Any reliance on this report by other parties shall be at such party's sole risk. Any future consultation or provision of services to third parties related to the subject property requires written authorization from Apex Energy Solutions, LLC or their representatives. Any such services may be provided at GS Lyon Consultants sole discretion and under terms and conditions acceptable to GS Lyon Consultants, including potential additional compensation.

2.0 SITE DESCRIPTION

2.1 Site Location and Legal Description

The approximately 280-acre subject property is located on the northeast side of the East Highline Canal and Niland Lateral 6 (APN 003-110-005 and 003-110-007) north of Niland, California. The subject property location is depicted on Plate 1, Vicinity Map.

2.2 Current Property Use and Description

The subject property currently consists of approximately 280 acres of vacant desert land. The subject property is irregular in plan view, elongate in the northwest-southeast direction. Several dirt trails cross the site. The subject property is covered with scattered dry desert brush. An existing power line is located along the northern boundary of the subject property. There are two dry washes that cross the subject property in a northeast to southwest direction. The washes are relatively shallow and mainly sheet flow across the subject property.

2.3 Adjoining Property Use

The subject property is located at the transition between vacant desert land to the east and north and agricultural lands to the south and west. A gravel borrow pit is located adjacent to the northwest corner of the subject property. A farming operation with temporary greenhouses is located adjacent to the southwest boundary of the subject property. The Coachella Canal is located to the east of the subject site with the active United States Department of Defense Chocolate Mountain Aerial Gunnery Range located east of the canal.

2.4 Physical Site Characteristics

Topography: Topographic maps (USGS 7.5 minute Wister, CA Quadrangle) indicate that the subject property elevation is approximately 20 feet above to 60 feet below mean sea level (MSL) or Elevation 1020 to 940 (local datum). The Imperial Irrigation District, which supplies power and raw (irrigation) water to the area, established local datum by equating mean sea level to El. 1000.00 feet.

Geologic Setting: The subject property is located in the Colorado Desert Physiographic province of southern California. The dominant feature of the Colorado Desert province is the Salton Trough, a geologic structural depression resulting from large-scale regional faulting. The trough is bounded on the northeast by the San Andreas Fault and the southwest by faults of the San Jacinto Fault Zone.

The Salton Trough represents northward extension of the Gulf of California, which has experienced continual in-filling with both marine and non-marine sediments since the Miocene Epoch (25 million years before present). The tectonic activity that formed the trough continues at a high rate as evidenced by deformed young sedimentary deposits and high levels of historic seismicity.

The subject property is directly underlain by Holocene (0-11,000 years before present) Cahuilla Lake sediments, which consist of interbedded lenticular and tabular sand, silt, and clay. The predominant surface soil is silty clay. The Holocene lake deposits are considered to be less than 100 feet thick and are characterized by surficial clay and silt deposits with varying amounts of fine sand. The topography of the Imperial Valley is relatively flat, with few significant land features. The valley floor slopes gently to the north (less than 0.5 percent) from an elevation of sea level at Calexico to approximately 225 feet below sea level at the Salton Sea.

Soil Conditions: The U. S. Soil Conservation Service compiled a map of surface soil conditions and published a soil survey report including maps in 1980. The soil survey maps indicate that surficial deposits at the subject property and surrounding area consist predominantly of sandy loams of the Niland soil group (see Appendix B). These loams are formed in sediment and alluvium of mixed origin (Colorado River overflows, fresh-water lake-bed sediments, and alluvial fan deposits). Based on Unified Soil Classification System presented in the Soils Survey Report, the permeability of these soils is expected to be high within the upper 2 feet and low below 2 feet below ground surface.

Groundwater Conditions: Groundwater in the vicinity of the subject property is brackish and is estimated at a depth of 15 to 30 feet below the ground surface. Depth to groundwater may fluctuate due to localized geologic conditions, precipitation, irrigation, drainage and construction practices in the region. Based on the regional topography, groundwater flow is assumed to be generally towards the southwest within the subject property area. Flow directions may also vary locally in the vicinity of the subject property.

3.0 USER PROVIDED INFORMATION

In order to qualify for one of the *Landowner Liability Protections (LLPs)* offered by the Small Business Liability Relief and Brownfields Revitalization Act of 2001 (the *Brownfields Amendments*), the *User* must provide the following information (if available) to the *environmental professional*. Failure to provide this information could result in a determination that *all appropriate inquiry* is not complete. The user was asked to provide information or knowledge of the following:

- Environmental cleanup liens that are filed or recorded against the subject property.
- Activity and land use limitations that are in place on the subject property or that have been filed or recorded in a registry.
- Specialized knowledge or experience of the person seeking to qualify for the LLPs.
- Relationship of the purchase price to the fair market value of the *property* if it were not contaminated.
- Commonly known or *reasonably ascertainable* information about the *property*.
- The degree of obviousness of the presence or likely presence of contamination at the *property*, and the ability to detect the contamination by appropriate investigation.
- The reason for preparation of this Phase I ESA.

A user questionnaire was provided to the user to aid in gathering information that may be pertinent to the evaluation of the subject property for environmental conditions. The completed user questionnaire is provided in Appendix I.

3.1 Title Records

GS Lyon reviewed preliminary title reports as part of this assessment and did not find past ownership or easements that would indicate environmentally hazardous uses on the parcels.

3.2 Environmental Liens or Activity and Use Limitations

An environmental lien is a charge, security, or encumbrance upon the title to a property to secure the payment of a cost, damage, debt, obligation, or duty arising out of response actions, cleanup, or other remediation of hazardous substances or petroleum products upon the property.

According to the User Questionnaire, Mr. Edgar Hernandez with ZGlobal is not aware of any Environmental Liens or Activity and Use Limitations associated with the subject property that have been filed or recorded under federal, tribal, state or local law (Appendix H).

GS Lyon Consultants contracted Environmental Data Resources, Inc. (EDR) of Shelton, Connecticut to conduct a search of environmental liens for the subject property. According to the EDR environmental lien report, there are no environmental liens associated with the subject property. The EDR environmental lien report is included in Appendix I.

3.3 Specialized Knowledge

According to the User Questionnaire, Mr. Hernandez is not aware of any specialized knowledge or experience associated with the subject property or nearby properties.

GS Lyon does not have any personal knowledge of the subject property.

3.4 Commonly Known or Reasonable Ascertainable Information

No information was provided by the Client regarding any commonly known or reasonably ascertainable information within the local community that is material to RECs in connection with the subject property.

3.5 Valuation Reduction for Environmental Issues

The client indicated that the purchase price of this property reasonably reflects the fair market value of the property with no discounts for environmental issues.

3.6 Owner, Property Manager, and Occupant Information

The current owner of the subject property is Mr. Stavros Kondilis.

The subject property is currently undeveloped desert land. No property manager or occupant information is available.

3.7 Previous Reports and Other Provided Documentation

No previous reports or other pertinent documentation was provided to GS Lyon for review during the course of this assessment.

4.0 RECORDS REVIEW

A review of historic aerial photographs (Appendix C), historic topographic maps (Appendix D), historic Sanborn Fire Insurance maps (Appendix E), governmental regulatory databases (Appendix F), other regulatory and agency databases (Appendix G), and historic telephone and city directories (Appendix H) was performed to evaluate potentially adverse environmental conditions resulting from previous ownership and uses of the subject property. The details of the review are presented in Sections 4.1 through 4.5 of this report.

4.1 Regulatory Database Review

4.1.1 Standard Environmental Record Sources

GS Lyon Consultants contracted Environmental Data Resources, Inc. (EDR) of Shelton, Connecticut which queries and maintains comprehensive environmental databases and historical information, including proprietary databases, aerial photography, topographic maps, Sanborn Maps, and city directories to generate a compilation of Federal, State and Tribal regulatory lists containing information regarding hazardous materials occurrences on or within the prescribed radii of ASTM E1527-13. The search of each database was conducted using the approximate minimum search distances from the subject property defined by the ASTM E1527-13 Standard. The purpose of the records review is to obtain and review *reasonably ascertainable* records that will help identify *recognized environmental conditions* or *historical recognized environmental conditions* in connection with the subject property.

EDR's Phase I ESA search package was ordered and performed on June 21, 2022. The search package included: Radius Map with Geocheck, aerial photographs, historic topographic maps, Sanborn maps, building permits, city directory, and property tax information.

The results of EDR's search were used to evaluate if the subject property and/or properties within prescribed search distances are listed as having a past or present record of actual or potential environmental impact. Inclusion of a property in a government database list does not necessarily indicate that the property has an environmental problem.

The following is a brief synopsis of sites identified in the EDR Radius Map with Geocheck report. The government record search report is included in its entirety in Appendix E.

Federal NPL List

The Environmental Protection Agency's (EPA) National Priorities List (NPL) of uncontrolled or abandoned hazardous waste sites was reviewed for risk sites within a 1 mile radius of the subject property. The NPL identifies sites for priority cleanup and long-term care of properties under the Superfund Program that are contaminated with hazardous substances.

The database search did not identify any NPL sites within 1 mile of the subject property.

Federal CERCLA List

The EPA's Comprehensive Environmental Response, Compensation, and Liability Information System (CERCLA) listings were reviewed to determine if risks sites within ½ mile are listed for investigation. The CERCLA database identifies hazardous waste sites that are on or proposed to be included in the NPL and sites that require investigation and possible remedial action to mitigate potential negative impacts on human health or the environment.

The CERCLA database search did not identify any risk sites within 0.5 mile of the subject property.

Federal CERCLA – No Further Remedial Action Planned

The EPA's CERCLA – No Further Remedial Action Planned (NFRAP) database was reviewed to determine if risks sites within ½ mile are listed. CERCLA NFRAP site are risk sites that have been removed from and archived from the inventory of CERCLA sites. Archived status indicates that, to the best of EPA's knowledge, assessment at the subject property has been completed and the EPA has determined that no further steps will be taken to list this subject property on the NPL, unless information indicates this decision was not appropriate or other considerations require a recommendation for listing at a later time.

This designation is for sites where no contamination was found, contamination was quickly removed without the need for the subject property to be placed on the NPL, or the contamination was not serious enough to require Federal Superfund action or NPL consideration.

The CERCLA – NFRAP database search did not identify any risk sites within ½mile of the subject property.

Federal RCRA List

The Federal Resource Conservation Recovery Act (RCRA) Notifiers List was reviewed to determine if RCRA treatment, storage or disposal sites (TSD) are located within 1 mile of the subject property. The RCRA Correction Action Sites List (CORRACTS) is maintained for risk sites which are undergoing “a corrective action”. A corrective action order is issued when there has been a release of hazardous waste constituents into the environment from a RCRA facility.

The RCRA and RCRA CORRACTS database searches did not identify any RCRA TSD or RCRA CORRACTS risk sites within ½ mile of the subject property.

The RCRA regulated hazardous waste generator notifiers list was reviewed to determine if RCRA generator facilities are located on or adjoining the subject property. No RCRA generator facilities within ¼ mile of the subject property were identified in the database.

Federal ERNS List

The Federal Emergency Response Notification System (ERNS) List was reviewed to determine if reported release of oil and/or hazardous substances occurred on the subject property.

The ERNS database searches did not identify any reported releases for the subject property.

State and Tribal NPL List

The Environmental Protection Agency’s (EPA) National Priorities List (NPL) of uncontrolled or abandoned hazardous waste sites was reviewed for risk sites within a 1 mile radius of the subject property. The NPL identifies sites for priority cleanup and long-term care of properties under the Superfund Program that are contaminated with hazardous substances.

The database search did not identify any NPL sites within 1 mile of the subject property.

State and Tribal equivalent CERCLA

The Department of Toxic Substances Control’s (DTSC’s) Site Mitigation and Brownfields Reuse Program’s (SMBRP’s) EnviroStor database identifies sites that have known contamination or sites for which there may be reasons to investigate further. The database includes the following site types: Federal Superfund sites (National Priorities List (NPL)); State Response, including Military Facilities and State Superfund; Voluntary Cleanup; and School sites.

EnviroStor provides similar information to the information that was available in CalSites, and provides additional site information, including, but not limited to, identification of formerly-contaminated properties that have been released for reuse, properties where environmental deed restrictions have been recorded to prevent inappropriate land uses, and risk characterization information that is used to assess potential impacts to public health and the environment at contaminated sites.

The EnviroStor database search did not identify any risk sites within 1 mile of the subject property.

State and Tribal Leaking Underground Storage Tank Sites

The California State Water Resources Control Board (SWRCB) maintains a list of information concerning reported leaking underground storage tanks (LUST). The LUST inventory list was reviewed to determine if any LUSTs are located within ½ mile the subject property.

The SWRCB LUST database did not identify any risk sites within ½ mile of the subject property.

State and Tribal Underground and Aboveground Storage Tank Sites

The California State Water Resource Control Board (SWRCB) underground storage tank (UST) and above ground storage tank (AST) inventory list was reviewed to determine if any UAST's are located on or adjacent to the subject property.

The SWRCB UAST database did not identify any risk sites within ½ mile of the subject property.

Solid Waste Disposal/Landfill Facilities

The Solid Waste Disposal/Landfill Sites records typically contain an inventory of solid waste disposal facilities or landfills in a particular state. The data comes from the Integrated Waste Management Board's Solid Waste Information System (SWIS) database.

A review of the SWF/LF list database did not identify any risk sites within ½ mile of the subject property.

Unmapped (Orphan) Sites

Not all sites or facilities identified in the database records can be accurately located in relation to the Subject Property due to incomplete information being supplied to the regulatory agencies and are referred to as “orphan sites” by EDR. No unmapped (orphan) listings were reported.

Additional Government Environmental Records

Additional government environmental record databases were reviewed. No listings in the following databases were found for the subject property:

CERS Hazardous Waste: List of sites in the California Environmental Protection Agency (CalEPA) Regulated Site Portal which fall under the Hazardous Chemical Management, Hazardous Waste Onsite Treatment, Household Hazardous Waste Collection, Hazardous Waste Generator, and RCRA LQ HW Generator programs.

HWTS: Hazardous Waste Tracking System. DTSC maintains the Hazardous Waste Tracking System that stores ID number information since the early 1980s and manifest data since 1993. The system collects both manifest copies from the generator and destination facility.

HAZNET: Facility and Manifest Data. The data is extracted from the copies of hazardous waste manifests received each year by the DTSC. The annual volume of manifests is typically 700,000 - 1,000,000 annually, representing approximately 350,000 - 500,000 shipments. Data are from the manifests submitted without correction, and therefore many contain some invalid values for data elements such as generator ID, TSD ID, waste category, and disposal method. This database begins with calendar year 1993.

FINDS: Facility Index System/Facility Registry System Facility Index System. FINDS contains both facility information and 'pointers' to other sources that contain more detail. EDR includes the following FINDS databases in this report: PCS (Permit Compliance System), AIRS (Aerometric Information Retrieval System), DOCKET (Enforcement Docket used to manage and track information on civil judicial enforcement cases for all environmental statutes), FURS (Federal Underground Injection Control), C-DOCKET (Criminal Docket System used to track criminal enforcement actions for all environmental statutes), FFIS (Federal Facilities Information System), STATE (State Environmental Laws and Statutes), and PADS (PCB Activity Data System).

HAULERS: A listing of registered waste tire haulers.

ECHO: Enforcement & Compliance History Information. ECHO provides integrated compliance and enforcement information for about 800,000 regulated facilities nationwide.

RCRC NonGen/NLR: RCRA NonGen / NLR: RCRA - Non Generators / No Longer Regulated RCRAInfo is EPA's comprehensive information system, providing access to data supporting the Resource Conservation and Recovery Act (RCRA) of 1976 and the Hazardous and Solid Waste Amendments (HSWA) of 1984. The database includes selective information on sites which generate, transport, store, treat and/or dispose of hazardous waste as defined by the Resource Conservation and Recovery Act (RCRA). Non-Generators do not presently generate hazardous waste.

4.1.2 Additional Environmental Record Sources

California Department of Toxic Substances Control (DTSC) Records – Envirostor Database: EnviroStor is an online search and Geographic Information System tool for identifying sites that have known contamination or sites for which there may be reasons to investigate further. Public Access to EnviroStor is accessible via the DTSC Web Page located at: <http://www.envirostor.dtsc.ca.gov/public/>. The EnviroStor database includes the following site types: Federal Superfund sites (National Priority List); State Response, including Military Facilities and State Superfund; Voluntary Cleanup; and School sites.

The information includes site name, site type, status, address, any restricted use (recorded deed restrictions), past use(s) that caused contamination, potential contaminants of concern, potential environmental media affected, site history, planned and completed activities. The EnviroStor database also contains current and historical information relating to Permitted and Corrective Action facilities. The EnviroStor database includes current and historical information on the following permit-related documents: facility permits; permit renewal applications; permit modifications to an existing permit; closure of hazardous waste management units (HWMUs) or entire facilities; facility corrective action (investigation and/or cleanup); and/or post-closure permits or other required post-closure activities.

The EnviroStor database was queried on August 23, 2022. A map showing the results of the query is provided in Appendix F. No reported cases were found on the subject property. No risk sites were located within ½ mile of the subject property.

California State Water Resources Control Board Records – GeoTracker Database: GeoTracker is a geographic information system (GIS) maintained by the California State Water Resources Control Board (SWRCB) that provides online access to environmental data at <http://www.geotracker.swrcb.ca.gov>. GeoTracker tracks regulatory data about underground fuel tanks, fuel pipelines, and public drinking water supplies. Site information from the Spills, Leaks, Investigations, and Cleanups (SLIC) Program is also included in GeoTracker.

The GeoTracker database was queried for environmental data pertaining to the Subject property on August 23, 2022. A map showing the results of the query is provided in Appendix F. No reported cases were found on the subject property. No risk sites were located within ½ mile of the subject property.

California Environmental Protection Agency (CalEPA) Records Search: CalEPA Regulated Site Portal is a website that combines data about environmentally regulated sites and facilities in California into a single, searchable database and interactive map. The portal was created to provide a more holistic view of regulated activities statewide. By combining data from a variety of state and federal databases, the portal provides an overview of regulated activities across the spectrum of environmental programs for any given location in California. These activities include hazardous materials and waste, state and federal cleanups, impacted ground and surface waters, and toxic materials. The portal combines information from the following databases: Cal/OSHA, California Environmental Reporting System (CERS), California Integrated Water Quality System (CIWQS), US EPA's Air Emission Inventory System (EIS), Envirostor, Geotracker, Stormwater Multiple Application and Report Tracking System (SMARTS), Solid Waste Information System (SWIS), and Toxics Release Inventory (TRI).

The CalEPA database was queried for environmental data pertaining to the subject property on August 23, 2022. A map showing the results of the query and the CalEPA information for identified risk sites are provided in Appendix G. No reported cases were found on the subject property. No risk sites were located within ½ mile of the subject property.

CUPA Records Search: The Unified Program consolidates, coordinates, and makes consistent the administrative requirements, permits, inspections, and enforcement activities of six environmental and emergency response programs. Cal/EPA and other state agencies set the standards for their programs while local governments implement the standards—these local implementing agencies are called Certified Unified Program Agencies (CUPA).

The DTSC Imperial CUPA office was contacted (on August 23, 2022). CUPA records were searched for environmental issues related to the subject property. The DTSC indicated that records are filed per address, and with no known address associated with the subject property, no records were found associated with the subject property.

4.2 Historical Use Records

ASTM E1527-13 requires the environmental professional to identify all obvious uses of the property from the present back to the property's first developed use or 1940, whichever is earliest. This information is collected to identify the likelihood that past uses have led to RECs in connection with the property. This task is accomplished by reviewing standard historical sources to the extent that they are necessary, reasonably ascertainable, and likely to be useful. These standard records include aerial photographs, fire insurance maps, property tax files, land title records, topographic maps, city directories, telephone directories, building department records, and zoning/land use records.

The general type of historical use (i.e., commercial, retail, residential, industrial, undeveloped, office) should be identified at 5-year intervals, unless the specific use of the property appears to be unchanged over a period longer than 5 years. The historical research is complete when the use is defined or when data failure occurs. Data failure occurs when all of the standard historical sources have been reviewed, yet the property use cannot be identified back to its first developed use or to 1940. Data failure is not uncommon in trying to identify the use of the property at 5-year intervals back to first use or 1940, whichever is earlier.

GS Lyon reviewed the following historical records to identify obvious uses of the subject property from the present back to the property's first developed use, or to 1940, whichever is earlier. The results of this research and data failure, if encountered, are presented in the following sections.

4.2.1 Title Records

GS Lyon reviewed preliminary title reports as part of this assessment and did not find past ownership or easements that would indicate environmentally hazardous uses on the parcels.

4.2.2 Sanborn Fire Insurance Maps

Sanborn Fire Insurance Maps are large scale maps depicting the commercial, industrial, and residential sections of various cities across the United States. Since the primary use of the fire insurance maps was to assess the buildings that were being insured, the existence and location of fuel storage tanks, flammable or other potentially toxic substances, and the nature of businesses are often shown on these maps.

Due to the rural undeveloped nature of the subject property and vicinity for the years the Sanborn Fire Insurance Maps were available for this subject property, no maps are available for the subject property.

4.2.3 Aerial Photographs

Aerial photographs obtained from Environmental Data Resources (EDR) dating back to 1937 and Google Earth aerial photographs dating back to 1996 were reviewed for historical development of the subject property. Reproductions of the historical aerial photographs reviewed are included in Appendix C.

The 1937 and 1949 aerial photographs show the subject site as being vacant desert lands. Surrounding properties are also vacant desert lands with small agricultural fields located to the southwest, southwest of the corner of the East Highline Canal and Niland Lateral 6.

The 1953, 1976 and 1985 aerial photographs are similar to the 1949 aerial photograph with additional agricultural fields shown near the subject property on the north side of the Niland Lateral 6 and east side of the East Highline Canal.

The 1992, 1996, 2002, 2006, 2009, 2012, and 2016 aerial photograph are similar to the 1985 aerial photograph with the addition of earthen raw water reservoirs adjacent to the southern tip of the subject property and to the west of the subject property.

4.2.4 Street Directories

GS Lyon Consultants contracted Environmental Data Resources, Inc. (EDR) of Shelton, Connecticut to conduct a search of historic city directories for the subject property (Appendix H). City directories are used for locating individuals and businesses in a particular urban or suburban area. City directories are generally divided into three sections: a business index, a list of resident names and addresses, the name and type of businesses (if unclear from the name). While city directory coverage is comprehensive for major cities, it may be spotty for rural and small towns.

EDR Digital Archives: The EDR Digital Archives City Directories for the years 1992, 1995, 2000, 2005, 2010, and 2014 were reviewed. No listings were found for the subject property and adjacent properties.

Polk City Directories: The Polk City Directories for the years 1959, 1963, 1967, 1972, 1977, 1982, and 1988 were reviewed. No listings were found for the subject property and adjacent properties.

4.2.5 Historic Topographic Maps

Historic topographic maps (1940, 1944, 1947, 1956, 1976, 1995, 2002, 2012, 2015 and 2018), showed the subject property as being vacant desert land with desert washes passing through the site (Appendix D).

4.2.6 Historical Telephone Directories

Telephone Directories: Telephone directories for the Imperial County, which included the City of Westmorland businesses published in 1941, 1955, and 1965 were reviewed. No service stations, chemical manufacturers, petroleum manufacturers, distributors, or automotive repair facilities were noted at or in the immediate vicinity of the subject property.

4.3 Historical Use Summary

4.3.1 Summary of the Historical Use of Property

Based on a review of the historical information, the subject property has been vacant desert land since prior to 1937.

4.3.2 Summary of the Historical Use of Adjacent Properties

Historically, the properties located immediately adjacent to the subject property have been comprised of vacant desert lands and the Chocolate Mountain Gunnery Range to the east. Agricultural development along the southwestern side of the subject property began in the 1950s with agricultural fields and orchards.

5.0 SITE RECONNAISSANCE

5.1 Methodology and Limiting Conditions

A site reconnaissance was performed by Mr. Pete LaBrucherie, a consulting engineer to GS Lyon Consultants, on August 31, 2022. The site visit consisted of a driving the perimeter of the subject property and randomly crossing the subject property. The reconnaissance included visual observations of surficial conditions at the subject property and observation of adjoining properties to the extent that they were visible from public areas. Mr. LaBrucherie was unaccompanied during the site reconnaissance.

The site reconnaissance was limited to visual and/or physical observation of the exterior and interior of the subject property and its improvements, the current uses of the property and adjoining properties, and the current condition of the property. The site visit evaluated the subject property and adjoining properties for potential hazardous materials/waste and petroleum product use, storage, disposal, or accidental release, including the following: presence of tank and drum storage; mechanical or electrical equipment likely to contain liquids; evidence of soil or pavement staining or stressed vegetation; ponds, pits, lagoons, or sumps; suspicious odors; fill and depressions; or any other condition indicative of potential contamination. The site visit did not evaluate the presence of asbestos-containing materials, radon, lead-based paint, mold, indoor air quality, or structural defects, or other non-scope items.

A site reconnaissance can be limited by weather conditions, bodies of water, adjacent buildings, or other obstacles. The weather was warm and sunny and no access limitations were placed on the site visit.

5.2 General Site Setting

The subject property currently consists of approximately 280 acres of vacant desert land. The subject property is irregular in plan view, elongate in the northwest-southeast direction. Several dirt trails cross the site. The subject property is covered with scattered dry desert brush. An existing power line is located along the northern boundary of the subject property. There are two dry washes that cross the subject property in a northeast to southwest direction. The washes are relatively shallow and mainly sheet flow across the subject property.

Photographs of the subject property taken on August 31, 2022 during our site reconnaissance are included in Appendix A.

5.3 Adjacent Properties

The subject property is located at the transition between vacant desert land to the east and north and agricultural lands to the south and west. A gravel borrow pit is located adjacent to the northwest corner of the subject property. A farming operation with temporary greenhouses is located adjacent to the southwest boundary of the subject property. The Coachella Canal is located to the east of the subject site with the active United States Department of Defense Chocolate Mountain Aerial Gunnery Range located east of the canal.

5.4 Exterior and Interior Observations

The following conditions were specifically assessed for their potential to indicate RECs and may include conditions inside or outside structures on the subject property.

5.4.1 Hazardous Substances and Petroleum Products

GS Lyon did not observe operations that use, treat, store, dispose of, or generate hazardous materials or petroleum products on the subject property.

5.4.2 Storage Tanks

Underground Storage Tanks (USTs) – No obvious visual evidence indicating the current presence of USTs (i.e. vent pipes, fill ports, etc.) was noted.

Aboveground Storage Tanks (ASTs) – No obvious visual evidence indicating the historical presence of ASTs (i.e. secondary containments, concrete saddles, etc.) was observed.

5.4.3 Odors

No obvious strong, pungent, or noxious odors were noted during the site reconnaissance.

5.4.4 Pools of Liquid

Pools of liquid were not observed during the site reconnaissance.

5.4.5 Drums and Containers

GS Lyon did not observe drums or storage containers on the subject property.

5.4.6 Unidentified Substance Containers

GS Lyon did not observe open or damaged containers containing unidentified substances at the subject property.

5.4.7 Suspect Polychlorinated Biphenyl (PCB) Containing Equipment

No potential PCB containing equipment such as electrical transformers, capacitors, and hydraulic equipment were observed during the site reconnaissance on the subject property or immediate vicinity.

5.5 Interior Observations

The subject property is currently vacant with no structures; therefore, no interior observations were made.

5.6 Exterior Observations

5.6.1 Pits, Ponds, and Lagoons

No pits, ponds, or lagoons were noted on the subject property.

5.6.2 Stained Soils or Pavement

No evidence of significantly stained soil or pavement was noted on the subject property.

5.6.3 Stressed Vegetation

No evidence of stressed vegetation attributed to potential contamination was noted on the subject property.

5.6.4 Solid Waste

No evidence of debris was found within the subject site.

5.6.5 Wastewater

No waste water is generated at the subject site.

5.6.6 Wells

No evidence of wells (dry wells, drinking water, observation wells, groundwater monitoring wells, irrigation wells, injection wells or abandoned wells) was noted on the subject property.

5.6.7 Septic Systems

No septic systems are present on the subject property.

5.7 Non-Scope Issues

ASTM guidelines identify non-scope issues, which are beyond the scope of a Phase I ESA as defined by ASTM. These issues may affect environmental risk at the subject property and may warrant discussion and/or assessment.

Some of these non-scope issues include; asbestos-containing building materials, radon, lead-based paint, and wetlands which are discussed below.

5.7.1 Asbestos-Containing Building Materials

The potential for asbestos containing materials (ACM) existing at the subject property is very low due to the lack of subject property structures.

5.7.2 Lead-Based Paint

The potential or lead based paint residues existing at the subject property is very low due to the lack of subject property development.

5.7.3 Radon

The subject property is located in Zone 3 as shown on the EPA Map of Radon Zones indicating a predicted average indoor radon screening level of less than 2 pCi/L; therefore, no further action is required. Radon gas is not believed to be a potential hazard at the subject property.

5.7.4 Wetlands

The large dry desert wash that crosses the middle of the subject site is designated as R4SBJ (Riverine Intermittent Streambed Intermittently Flooded) in the National Wetlands Inventory Mapper. Properties adjacent to the western boundary of the subject site include PSS1A/B/C (Palustrine Scrub-Shrub Broad-Leaved Deciduous Temporary Flooded/Seasonally Saturated/Seasonally Flooded), PEM1B (Palustrine Emergent Persistent Seasonally Saturated) and PUBH fresh water ponds (Palustrine Unconsolidated Bottom Permanently Flooded) from the National Wetlands Inventory Mapper.

5.7.5 Agricultural Use

Based on our review of environmental records, historical documents, and subject property conditions, the property has not been in agricultural use; therefore the likelihood of residues of currently available pesticides and currently banned pesticides such as DDT/DDE existing on the subject site is very low.

6.0 INTERVIEWS

GS Lyon attempted to interview various individuals familiar with the subject property in order to evaluate historical uses and identify potential RECs existing on the subject property. *Interviews with past owners, operators and occupants were not reasonably ascertainable and thus constitute a data gap.*

6.1 Interview with Owner

GS Lyon was not able to contact the current property owner; therefore, no interview was conducted.

6.2 Interview with the Site Manager

The subject property is vacant, undeveloped land; therefore, there is no site manager.

6.3 Interview with Occupants

The subject property is vacant, undeveloped land; therefore, there are no occupants.

6.4 Interview with Local Government Officials

The DTSC Imperial CUPA office was contacted on August 23, 2022. CUPA records were searched for environmental issues related to the subject property. The DTSC indicated that records are filed per address, and with no known address associated with the subject property, no records were found associated with the subject property.

7.0 EVALUATION

7.1 Summary of Findings

The approximately 280-acre property located on the east side of the East Highline Canal north of the Niland Lateral 6 north of Niland, California has been vacant desert land since prior to 1937.

7.2 Conclusions

GS Lyon has performed a Phase I Environmental Site Assessment in general conformance with the scope and limitations of ASTM E1527-13 of the approximately 280-acre property located on the east side of the East Highline Canal north of the Niland Lateral 6 north of Niland, California. Any exceptions to, or deviations from, this practice are described in Section 1.4 of this Phase I ESA report. This assessment has revealed the following recognized environmental conditions (RECs) in connection with the subject property:

7.2.1 Recognized Environmental Conditions

A recognized environmental condition (REC) refers to the presence or likely presence of any hazardous substances or petroleum products in, on, or at a property: (1) due to any release to the environment; (2) under conditions indicative of a release to the environment; or (3) under conditions that pose a material threat of a future release to the environment. under conditions that indicate an existing release, a past release, or a material threat of a release of any hazardous substances or petroleum products into structures on the property or into the ground, groundwater, or surface water of the property. The term REC includes hazardous substances and petroleum products even under conditions that might be in compliance with laws. The term is not intended to include "de minimis" conditions as defined in Section 7.2.3 of this report.

This assessment has revealed no evidence of RECs for the study subject property:

7.2.2 Historical Recognized Environmental Conditions

A historical recognized environmental condition (HREC) refers to a past *release* of any *hazardous substances* or *petroleum products* that has occurred in connection with the *property* and has been addressed to the satisfaction of the applicable regulatory authority or meeting unrestricted use criteria established by a regulatory authority, without subjecting the *property* to any required controls (for example, *property* use restrictions, *activity and use limitations*, *institutional controls*, or *engineering controls*).

This Phase I ESA has revealed no evidence of *historical recognized environmental conditions* in connection with the subject property.

7.2.3 Environmental Concerns and De Minimis Conditions

A *de minimis condition* is a condition that generally does not present a threat to human health or the *environment* and that generally would not be the subject of an enforcement action if brought to the attention of appropriate governmental agencies. Conditions determined to be *de minimis conditions* are not *recognized environmental conditions* nor *controlled recognized environmental conditions*.

This Phase I ESA has revealed no *de minimis* conditions or environmental concerns in connection with the subject property.

7.3 Recommendations

Based on the scope of work performed for this assessment, it is our professional opinion that no RECs have been identified in connection with the subject property that would warrant further environmental study (Phase II) at this time.

8.0 REFERENCES

40 CFR 312, Standards and Practices for All Appropriate Inquiries; Final Rule, November 2005 (AAI Rule).

American Society for Testing and Materials. 2013. Standard Practice for Environmental Site Assessments: Phase I Environmental Site Assessment Process. Designation E 1527-13. West Conshohocken, Pennsylvania. 35 pp.

California Environmental Protection Agency (CalEPA). CalEPA Regulated Site Portal, <https://siteportal.calepa.ca.gov/nsite/map/help> accessed via the Internet, August 2022.

Department of Toxic Substances Control. EnviroStor Database Website, <http://www.envirostor.dtsc.ca.gov/public/> accessed via the Internet, August 2022.

Environmental Data Resources, Inc., *The EDR Radius Map with Geocheck*. Inquiry number 7022950, dated June 17, 2022

Environmental Data Resources, Inc., *The EDR-City Directory Abstract*. Inquiry number 7022950, dated June 17, 2022

Environmental Data Resources, Inc., *EDR Historical Topographic Map Report*. Inquiry number 7022950, dated June 17, 2022

Environmental Data Resources, Inc., *The EDR Aerial Photo Decade Package*. Inquiry number 7022950, dated June 17, 2022

Environmental Data Resources, Inc., *Sanborn Map Report*. Inquiry number 7022950, dated June 17, 2022

Environmental Data Resources, Inc., *The EDR Property Tax Map Report*. Inquiry number 7022950, dated June 17, 2022

State Water Resources Control Board. GeoTracker Database Website, <http://geotracker.swrcb.ca.gov/> accessed via the Internet, August 2022

United States Department of Agriculture, Natural Resources Conservation Service, Web Soil Survey, accessed via the Internet, August 2022

United States Environmental Protection Agency, EPA Map of Radon Zones (Document EPA-402-R-93-071), accessed via the Internet, August 2022

United States Geological Survey Topographic Map, 7.5 minute series

APPENDIX A



Photo 1: Looking east from the middle of the western boundary of the subject site at the entrance to the site from the East Highline Canal siphon.



Photo 2: Looking west within the main wash from the middle of the subject site.



Photo 3: Looking southwest from the middle of the subject site.



Photo 4: Looking east to southeast from the middle of the subject site.



Photo 5: Looking north to northeast from the middle of the subject site.



Photo 6: Looking north toward the northern boundary of the subject site located near the power transmission line.



Photo 7: Looking west from the northern portion of the subject site.



Photo 8: Looking east from the northern portion of the subject site.



Photo 9: Looking west along the dry wash near the northern boundary of the subject site.



Photo 10: Looking south from the northwest corner of the subject site.



Photo 11: Looking southwest from the northwest corner of the subject site toward the adjacent property with some abandoned small wood structures.



Photo 12: Looking north from the western boundary the subject site along one of the dry washes.

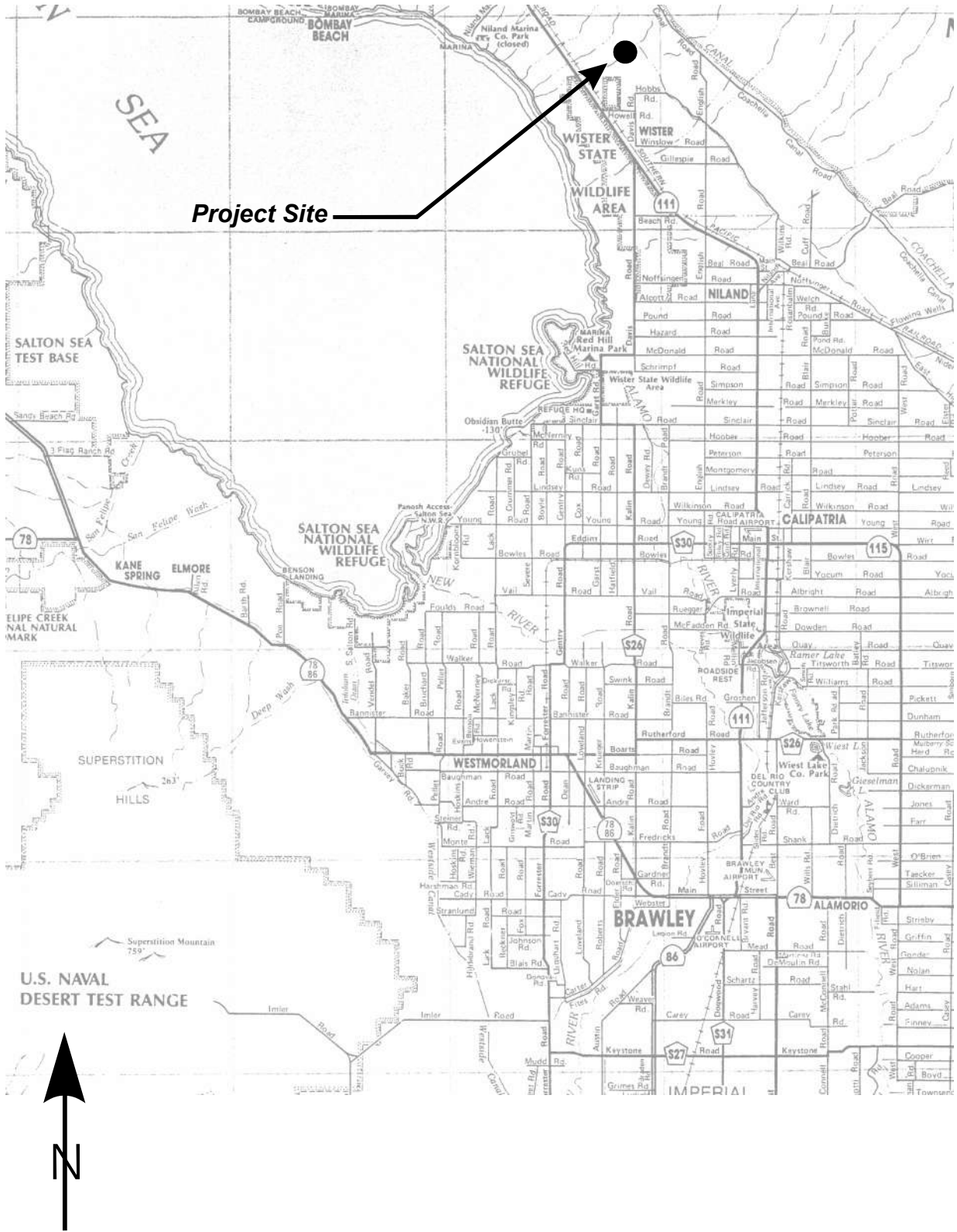

Photo 13: Looking west from the southern portion of the subject site. White structures in the far end of the picture are from the adjacent farming operation “green houses”.



Photo 14: Looking north from the southern boundary of the subject site.

APPENDIX B



Project Site



Project No.: GS2219

Vicinity Map

Plate
A-1

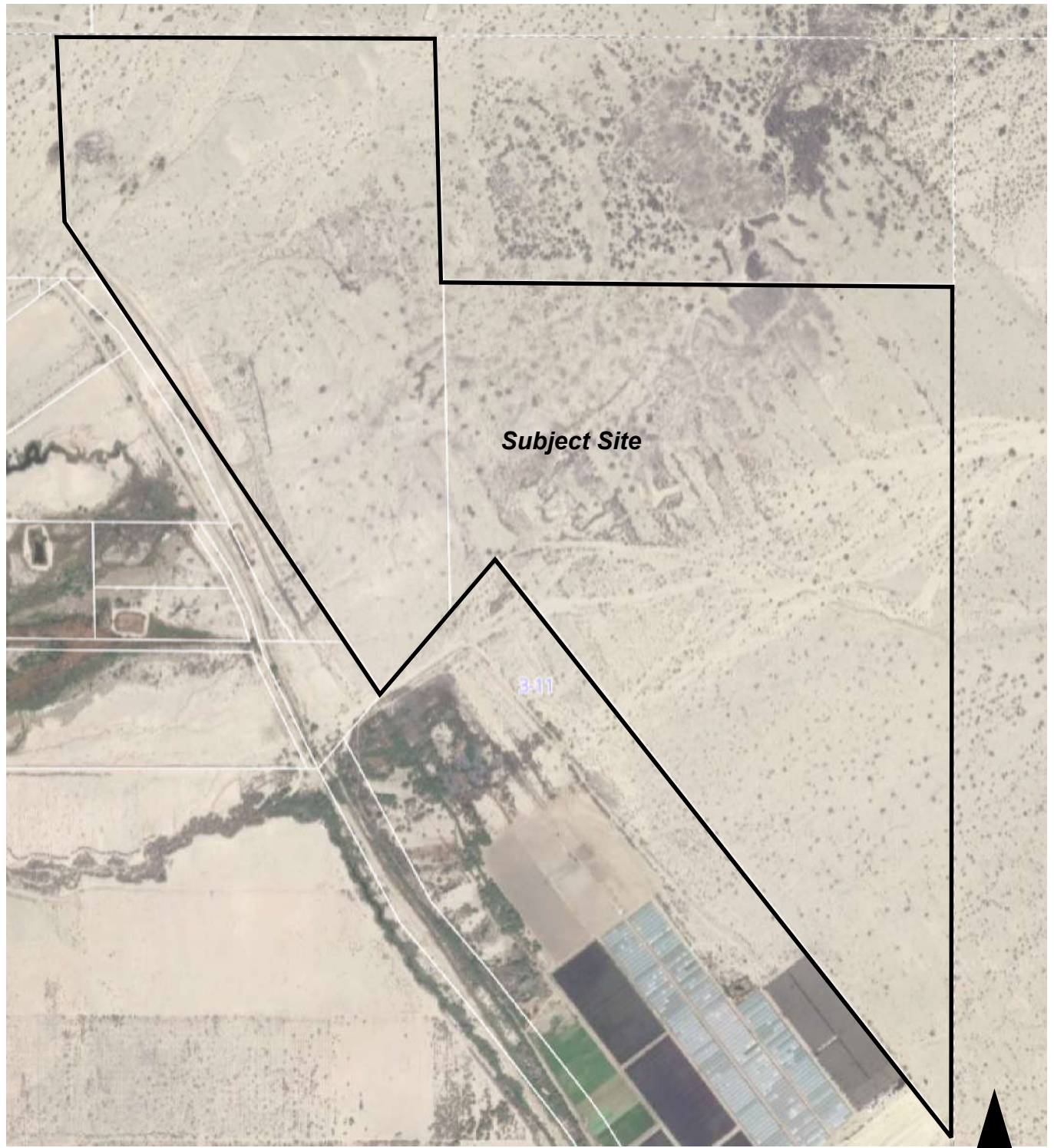

Subject Site

3-11



GS Lyon

Project No.: GS2219

Site Map

Plate
2

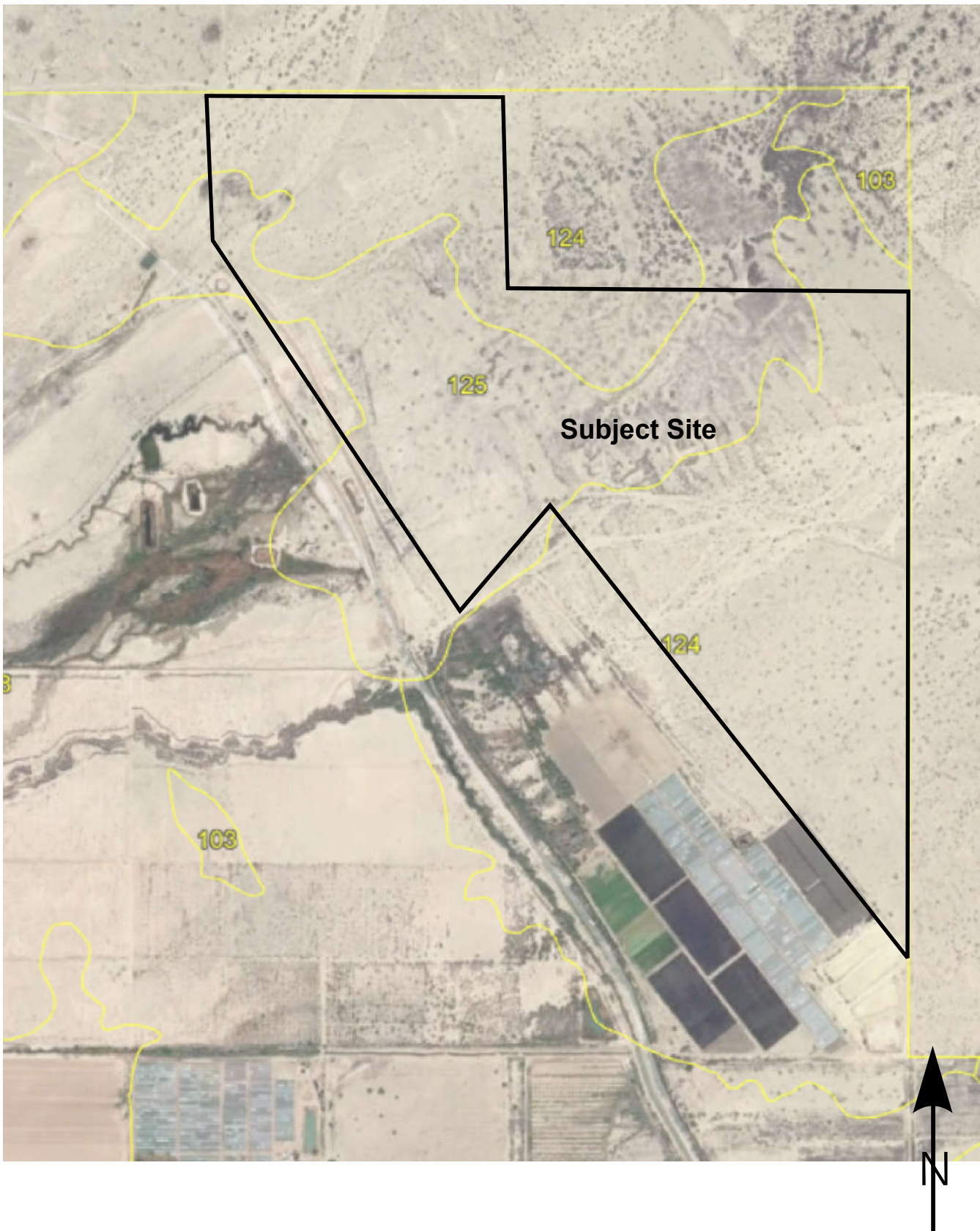

GS Lyon

Project No.: GS2219

Soil Survey Map

Plate
3

Soil Survey of

**IMPERIAL COUNTY
CALIFORNIA
IMPERIAL VALLEY AREA**

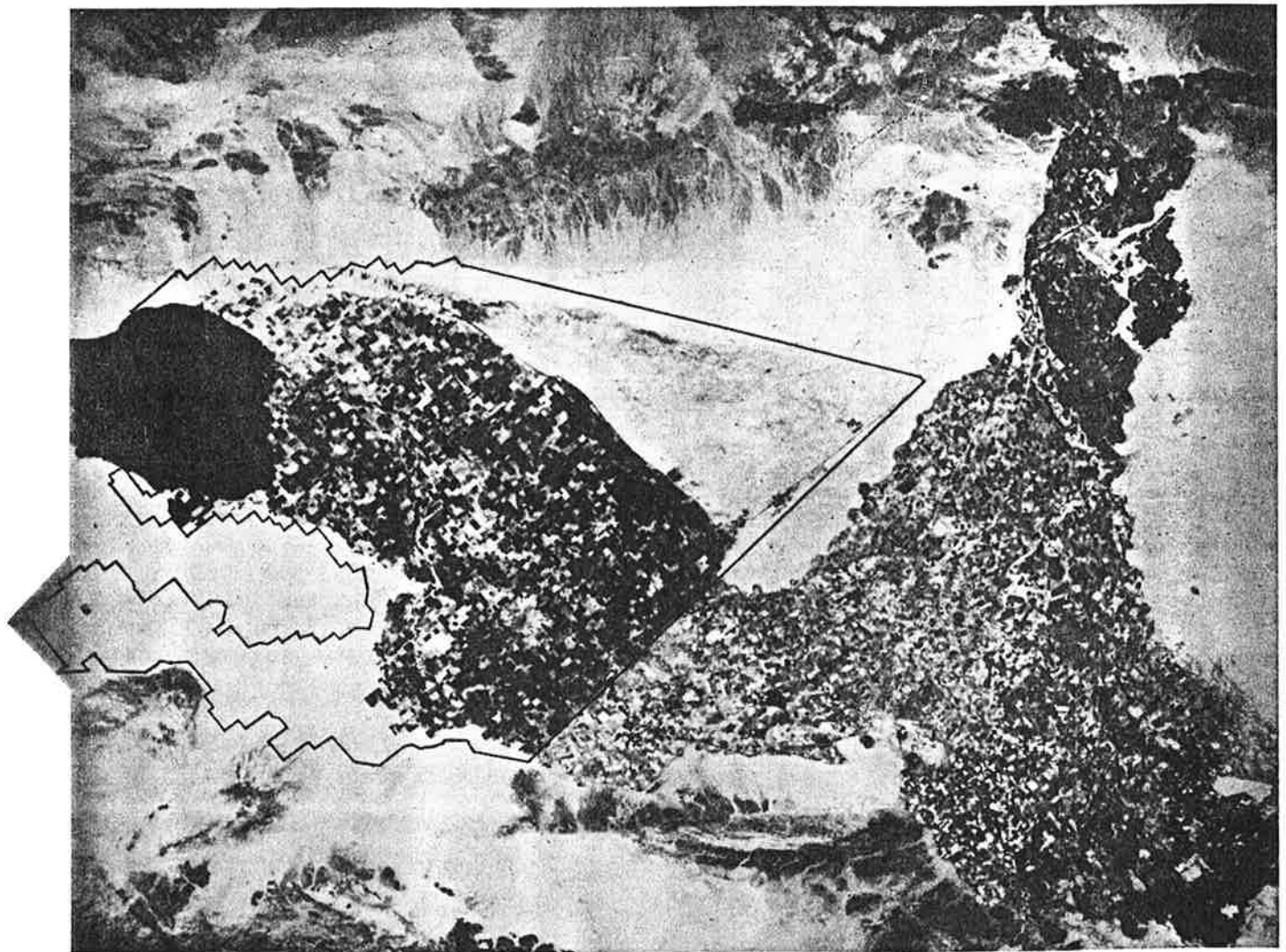

United States Department of Agriculture Soil Conservation Service
in cooperation with
University of California Agricultural Experiment Station
and
Imperial Irrigation District

TABLE 11.--ENGINEERING INDEX PROPERTIES

[The symbol > means more than. Absence of an entry indicates that data were not estimated]

Soil name and map symbol	Depth	USDA texture	Classification		Frag-ments > 3 inches	Percentage passing sieve number--				Liquid limit	Plas-ticity index
			Unified	AASHTO		4	10	40	200		
	In				Pct					Pct	
100-----	0-13	Loamy fine sand	SM	A-2	0	100	100	75-85	10-30	---	NP
Antho	13-60	Sandy loam, fine sandy loam.	SM	A-2, A-4	0	90-100	75-95	50-60	15-40	---	NP
101*:											
Antho-----	0-8	Loamy fine sand	SM	A-2	0	100	100	75-85	10-30	---	NP
	8-60	Sandy loam, fine sandy loam.	SM	A-2, A-4	0	90-100	75-95	50-60	15-40	---	NP
Superstition-----	0-6	Fine sand-----	SM	A-2	0	100	95-100	70-85	15-25	---	NP
	6-60	Loamy fine sand, fine sand, sand.	SM	A-2	0	100	95-100	70-85	15-25	---	NP
102*.											
Badland											
103-----	0-10	Gravelly sand---	SP, SP-SM	A-1, A-2	0-5	60-90	50-85	30-55	0-10	---	NP
Carsitas	10-60	Gravelly sand, gravelly coarse sand, sand.	SP, SP-SM	A-1	0-5	60-90	50-85	25-50	0-10	---	NP
104*											
Fluvaquents											
105-----	0-13	Clay loam-----	CL	A-6	0	100	100	90-100	70-95	35-45	15-30
Glenbar	13-60	Clay loam, silty clay loam.	CL	A-6	0	100	100	90-100	70-95	35-45	15-30
106-----	0-13	Clay loam-----	CL	A-6, A-7	0	100	100	90-100	70-95	35-45	15-25
Glenbar	13-60	Clay loam, silty clay loam.	CL	A-6, A-7	0	100	100	90-100	70-95	35-45	15-25
107*-----	0-13	Loam-----	ML, CL-ML, CL	A-4	0	100	100	100	70-80	20-30	NP-10
Glenbar	13-60	Clay loam, silty clay loam.	CL	A-6, A-7	0	100	100	95-100	75-95	35-45	15-30
108-----	0-14	Loam-----	ML	A-4	0	100	100	85-100	55-95	25-35	NP-10
Holtville	14-22	Clay, silty clay	CL, CH	A-7	0	100	100	95-100	85-95	40-65	20-35
	22-60	Silt loam, very fine sandy loam.	ML	A-4	0	100	100	95-100	65-85	25-35	NP-10
109-----	0-17	Silty clay-----	CL, CH	A-7	0	100	100	95-100	85-95	40-65	20-35
Holtville	17-24	Clay, silty clay	CL, CH	A-7	0	100	100	95-100	85-95	40-65	20-35
	24-35	Silt loam, very fine sandy loam.	ML	A-4	0	100	100	95-100	65-85	25-35	NP-10
	35-60	Loamy very fine sand, loamy fine sand.	SM, ML	A-2, A-4	0	100	100	75-100	20-55	---	NP
110-----	0-17	Silty clay-----	CH, CL	A-7	0	100	100	95-100	85-95	40-65	20-35
Holtville	17-24	Clay, silty clay	CH, CL	A-7	0	100	100	95-100	85-95	40-65	20-35
	24-35	Silt loam, very fine sandy loam.	ML	A-4	0	100	100	95-100	55-85	25-35	NP-10
	35-60	Loamy very fine sand, loamy fine sand.	SM, ML	A-2, A-4	0	100	100	75-100	20-55	---	NP

See footnote at end of table.

TABLE 11.--ENGINEERING INDEX PROPERTIES--Continued

Soil name and map symbol	Depth	USDA texture	Classification		Frag-ments > 3 inches	Percentage passing sieve number--				Liquid limit	Plas-ticity index
			Unified	AASHTO		4	10	40	200		
	In				Pct					Pct	
111*: Holtville-----	0-10	Silty clay loam	CL, CH	A-7	0	100	100	95-100	85-95	40-65	20-35
	10-22	Clay, silty clay	CL, CH	A-7	0	100	100	95-100	85-95	40-65	20-35
	22-60	Silt loam, very fine sandy loam.	ML	A-4	0	100	100	95-100	65-85	25-35	NP-10
Imperial-----	0-12	Silty clay loam	CL	A-7	0	100	100	100	85-95	40-50	10-20
	12-60	Silty clay loam, silty clay, clay.	CH	A-7	0	100	100	100	85-95	50-70	25-45
112-----	0-12	Silty clay-----	CH	A-7	0	100	100	100	85-95	50-70	25-45
Imperial	12-60	Silty clay loam, silty clay, clay.	CH	A-7	0	100	100	100	85-95	50-70	25-45
113-----	0-12	Silty clay-----	CH	A-7	0	100	100	100	85-95	50-70	25-45
Imperial	12-60	Silty clay, clay, silty clay loam.	CH	A-7	0	100	100	100	85-95	50-70	25-45
114-----	0-12	Silty clay-----	CH	A-7	0	100	100	100	85-95	50-70	25-45
Imperial	12-60	Silty clay loam, silty clay, clay.	CH	A-7	0	100	100	100	85-95	50-70	25-45
115*: Imperial-----	0-12	Silty clay loam	CL	A-7	0	100	100	100	85-95	40-50	10-20
	12-60	Silty clay loam, silty clay, clay.	CH	A-7	0	100	100	100	85-95	50-70	25-45
Glenbar-----	0-13	Silty clay loam	CL	A-6, A-7	0	100	100	90-100	70-95	35-45	15-25
	13-60	Clay loam, silty clay loam.	CL	A-6, A-7	0	100	100	90-100	70-95	35-45	15-25
116*: Imperial-----	0-13	Silty clay loam	CL	A-7	0	100	100	100	85-95	40-50	10-20
	13-60	Silty clay loam, silty clay, clay.	CH	A-7	0	100	100	100	85-95	50-70	25-45
Glenbar-----	0-13	Silty clay loam	CL	A-6, A-7	0	100	100	90-100	70-95	35-45	15-25
	13-60	Clay loam, silty clay loam.	CL	A-6	0	100	100	90-100	70-95	35-45	15-30
117, 118-----	0-12	Loam-----	ML	A-4	0	95-100	95-100	85-100	75-90	20-30	NP-5
Indio	12-72	Stratified loamy very fine sand to silt loam.	ML	A-4	0	95-100	95-100	85-100	75-90	20-30	NP-5
119*: Indio-----	0-12	Loam-----	ML	A-4	0	95-100	95-100	85-100	75-90	20-30	NP-5
	12-72	Stratified loamy very fine sand to silt loam.	ML	A-4	0	95-100	95-100	85-100	75-90	20-30	NP-5
Vint-----	0-10	Loamy fine sand	SM	A-2	0	95-100	95-100	70-80	25-35	---	NP
	10-60	Loamy sand, loamy fine sand.	SM	A-2	0	95-100	95-100	70-80	20-30	---	NP
120*: Laveen-----	0-12	Loam-----	ML, CL-ML	A-4	0	100	95-100	75-85	55-65	20-30	NP-10
	12-60	Loam, very fine sandy loam.	ML, CL-ML	A-4	0	95-100	85-95	70-80	55-65	15-25	NP-10

See footnote at end of table.

TABLE 11.--ENGINEERING INDEX PROPERTIES--Continued

Soil name and map symbol	Depth In	USDA texture	Classification		Frag- ments > 3 inches Pct	Percentage passing sieve number--				Liquid limit Pet	Plas- ticity index
			Unified	AASHTO		4	10	40	200		
121----- Meloland	0-12	Fine sand-----	SM, SP-SM	A-2, A-3	0	95-100	90-100	75-100	5-30	---	NP
	12-26	Stratified loamy fine sand to silt loam.	ML	A-4	0	100	100	90-100	50-65	25-35	NP-10
	26-71	Clay, silty clay, silty clay loam.	CL, CH	A-7	0	100	100	95-100	85-95	40-65	20-40
122----- Meloland	0-12	Very fine sandy loam.	ML	A-4	0	95-100	95-100	95-100	55-85	25-35	NP-10
	12-26	Stratified loamy fine sand to silt loam.	ML	A-4	0	100	100	90-100	50-70	25-35	NP-10
	26-71	Clay, silty clay, silty clay loam.	CH, CL	A-7	0	100	100	95-100	85-95	40-65	20-40
123*: Meloland-----	0-12	Loam-----	ML	A-4	0	95-100	95-100	95-100	55-85	25-35	NP-10
	12-26	Stratified loamy fine sand to silt loam.	ML	A-4	0	100	100	90-100	50-70	25-35	NP-10
	26-38	Clay, silty clay, silty clay loam.	CH, CL	A-7	0	100	100	95-100	85-95	40-65	20-40
	38-60	Stratified silt loam to loamy fine sand.	SM, ML	A-4	0	100	100	75-100	35-55	25-35	NP-10
Holtville-----	0-12	Loam-----	ML	A-4	0	100	100	85-100	55-95	25-35	NP-10
	12-24	Clay, silty clay	CH, CL	A-7	0	100	100	95-100	85-95	40-65	20-35
	24-36	Silt loam, very fine sandy loam.	ML	A-4	0	100	100	95-100	55-85	25-35	NP-10
	36-60	Loamy very fine sand, loamy fine sand.	SM, ML	A-2, A-4	0	100	100	75-100	20-55	---	NP
124, 125----- Niland	0-23	Gravelly sand---	SM, SP-SM	A-2, A-3	0	90-100	70-95	50-65	5-25	---	NP
	23-60	Silty clay, clay, clay loam.	CL, CH	A-7	0	100	100	85-100	80-95	40-65	20-40
126----- Niland	0-23	Fine sand-----	SM, SP-SM	A-2, A-3	0	90-100	90-100	50-65	5-25	---	NP
	23-60	Silty clay-----	CL, CH	A-7	0	100	100	85-100	80-95	40-65	20-40
127----- Niland	0-23	Loamy fine sand	SM	A-2	0	90-100	90-100	50-65	15-30	---	NP
	23-60	Silty clay-----	CL, CH	A-7	0	100	100	85-100	80-95	40-65	20-40
128*: Niland-----	0-23	Gravelly sand---	SM, SP-SM	A-2, A-3	0	90-100	70-95	50-65	5-25	---	NP
	23-60	Silty clay, clay, clay loam.	CL, CH	A-7	0	100	100	85-100	80-100	40-65	20-40
Imperial-----	0-12	Silty clay-----	CH	A-7	0	100	100	100	85-95	50-70	25-45
	12-60	Silty clay loam, silty clay, clay.	CH	A-7	0	100	100	100	85-95	50-70	25-45
129*: Pits											
130, 131----- Rositas	0-27	Sand-----	SP-SM	A-3, A-1, A-2	0	100	80-100	40-70	5-15	---	NP
	27-60	Sand, fine sand, loamy sand.	SM, SP-SM	A-3, A-2, A-1	0	100	80-100	40-85	5-30	---	NP

See footnote at end of table.

TABLE 11.--ENGINEERING INDEX PROPERTIES--Continued

Soil name and map symbol	Depth	USDA texture	Classification		Frag-ments > 3 inches	Percentage passing sieve number--				Liquid limit	Plas-ticity index
			Unified	AASHTO		4	10	40	200		
	In				Pct					Pct	
132, 133, 134, 135-Rositas	0-9	Fine sand-----	SM	A-3, A-2	0	100	80-100	50-80	10-25	---	NP
	9-60	Sand, fine sand, loamy sand.	SM, SP-SM	A-3, A-2, A-1	0	100	80-100	40-85	5-30	---	NP
136-----Rositas	0-4	Loamy fine sand	SM	A-1, A-2	0	100	80-100	40-85	10-35	---	NP
	4-60	Sand, fine sand, loamy sand.	SM, SP-SM	A-3, A-2, A-1	0	100	80-100	40-85	5-30	---	NP
137-----Rositas	0-12	Silt loam-----	ML	A-4	0	100	100	90-100	70-90	20-30	NP-5
	12-60	Sand, fine sand, loamy sand.	SM, SP-SM	A-3, A-2, A-1	0	100	80-100	40-85	5-30	---	NP
138*: Rositas-----	0-4	Loamy fine sand	SM	A-1, A-2	0	100	80-100	40-85	10-35	---	NP
	4-60	Sand, fine sand, loamy sand.	SM, SP-SM	A-3, A-2, A-1	0	100	80-100	40-85	5-30	---	NP
Superstition-----	0-6	Loamy fine sand	SM	A-2	0	100	95-100	70-85	15-25	---	NP
	6-60	Loamy fine sand, fine sand, sand.	SM	A-2	0	100	95-100	70-85	15-25	---	NP
139-----Superstition	0-6	Loamy fine sand	SM	A-2	0	100	95-100	70-85	15-25	---	NP
	6-60	Loamy fine sand, fine sand, sand.	SM	A-2	0	100	95-100	70-85	15-25	---	NP
140*: Torriorthents											
Rock outcrop											
141*: Torriorthents											
Orthids											
142-----Vint	0-10	Loamy very fine sand.	SM, ML	A-4	0	100	100	85-95	40-65	15-25	NP-5
	10-60	Loamy fine sand	SM	A-2	0	95-100	95-100	70-80	20-30	---	NP
143-----Vint	0-12	Fine sandy loam	ML, CL-ML, SM, SM-SC	A-4	0	100	100	75-85	45-55	15-25	NP-5
	12-60	Loamy sand, loamy fine sand.	SM	A-2	0	95-100	95-100	70-80	20-30	---	NP
144*: Vint-----	0-10	Very fine sandy loam.	SM, ML	A-4	0	100	100	85-95	40-65	15-25	NP-5
	10-40	Loamy fine sand	SM	A-2	0	95-100	95-100	70-80	20-30	---	NP
	40-60	Silty clay-----	CL, CH	A-7	0	100	100	95-100	85-95	40-65	20-35
Indio-----	0-12	Very fine sandy loam.	ML	A-4	0	95-100	95-100	85-100	75-90	20-30	NP-5
	12-40	Stratified loamy very fine sand to silt loam.	ML	A-4	0	95-100	95-100	85-100	75-90	20-30	NP-5
	40-72	Silty clay-----	CL, CH	A-7	0	100	100	95-100	85-95	40-65	20-35

* See description of the map unit for composition and behavior characteristics of the map unit.

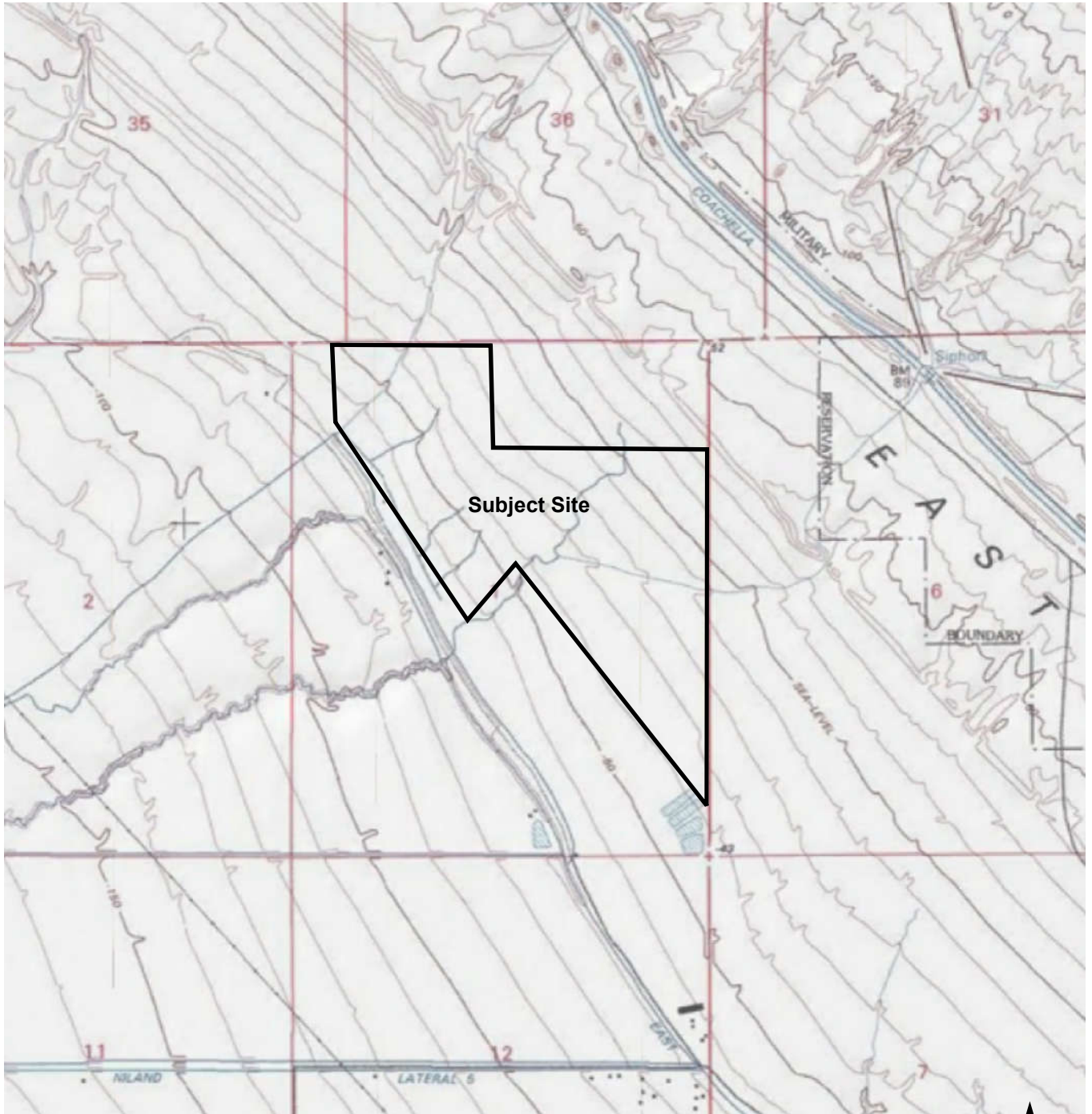

GS Lyon

Project No.: GS2219

Topographic Map

Plate
4

APPENDIX C



Northstar 1 Solar Project

EHL Canal and Niland Lateral 6

Calipatria, CA 92233

Inquiry Number: 7022950.11

June 21, 2022

The EDR Aerial Photo Decade Package



6 Armstrong Road, 4th floor
Shelton, CT 06484
Toll Free: 800.352.0050
www.edrnet.com

EDR Aerial Photo Decade Package

06/21/22

Site Name:

Northstar 1 Solar Project
EHL Canal and Niland Lateral (EHL)
Calipatria, CA 92233
EDR Inquiry # 7022950.11

Client Name:

GS Lyon Consultants
780 N. Fourth Street
El Centro, CA 92243
Contact: Steven Williams



Environmental Data Resources, Inc. (EDR) Aerial Photo Decade Package is a screening tool designed to assist environmental professionals in evaluating potential liability on a target property resulting from past activities. EDR's professional researchers provide digitally reproduced historical aerial photographs, and when available, provide one photo per decade.

Search Results:

<u>Year</u>	<u>Scale</u>	<u>Details</u>	<u>Source</u>
2016	1"=875'	Flight Year: 2016	USDA/NAIP
2012	1"=875'	Flight Year: 2012	USDA/NAIP
2009	1"=875'	Flight Year: 2009	USDA/NAIP
2006	1"=875'	Flight Year: 2006	USDA/NAIP
2002	1"=875'	Acquisition Date: January 01, 2002	USGS/DOQQ
1996	1"=875'	Acquisition Date: January 01, 1996	USGS/DOQQ
1992	1"=875'	Acquisition Date: January 01, 1992	USGS/DOQQ
1985	1"=875'	Flight Date: January 01, 1985	USDA
1976	1"=875'	Flight Date: October 12, 1976	USGS
1953	1"=875'	Flight Date: April 29, 1953	USDA
1949	1"=875'	Flight Date: February 18, 1949	USDA
1937	1"=875'	Flight Date: November 19, 1937	USDA

When delivered electronically by EDR, the aerial photo images included with this report are for ONE TIME USE ONLY. Further reproduction of these aerial photo images is prohibited without permission from EDR. For more information contact your EDR Account Executive.

Disclaimer - Copyright and Trademark Notice

This Report contains certain information obtained from a variety of public and other sources reasonably available to Environmental Data Resources, Inc. It cannot be concluded from this Report that coverage information for the target and surrounding properties does not exist from other sources. NO WARRANTY EXPRESSED OR IMPLIED, IS MADE WHATSOEVER IN CONNECTION WITH THIS REPORT. ENVIRONMENTAL DATA RESOURCES, INC. SPECIFICALLY DISCLAIMS THE MAKING OF ANY SUCH WARRANTIES, INCLUDING WITHOUT LIMITATION, MERCHANTABILITY OR FITNESS FOR A PARTICULAR USE OR PURPOSE. ALL RISK IS ASSUMED BY THE USER. IN NO EVENT SHALL ENVIRONMENTAL DATA RESOURCES, INC. BE LIABLE TO ANYONE, WHETHER ARISING OUT OF ERRORS OR OMISSIONS, NEGLIGENCE, ACCIDENT OR ANY OTHER CAUSE, FOR ANY LOSS OF DAMAGE, INCLUDING, WITHOUT LIMITATION, SPECIAL, INCIDENTAL, CONSEQUENTIAL, OR EXEMPLARY DAMAGES. ANY LIABILITY ON THE PART OF ENVIRONMENTAL DATA RESOURCES, INC. IS STRICTLY LIMITED TO A REFUND OF THE AMOUNT PAID FOR THIS REPORT. Purchaser accepts this Report "AS IS". Any analyses, estimates, ratings, environmental risk levels or risk codes provided in this Report are provided for illustrative purposes only, and are not intended to provide, nor should they be interpreted as providing any facts regarding, or prediction or forecast of, any environmental risk for any property. Only a Phase I Environmental Site Assessment performed by an environmental professional can provide information regarding the environmental risk for any property. Additionally, the information provided in this Report is not to be construed as legal advice.

Copyright 2022 by Environmental Data Resources, Inc. All rights reserved. Reproduction in any media or format, in whole or in part, of any report or map of Environmental Data Resources, Inc., or its affiliates, is prohibited without prior written permission.

EDR and its logos (including Sanborn and Sanborn Map) are trademarks of Environmental Data Resources, Inc. or its affiliates. All other trademarks used herein are the property of their respective owners.

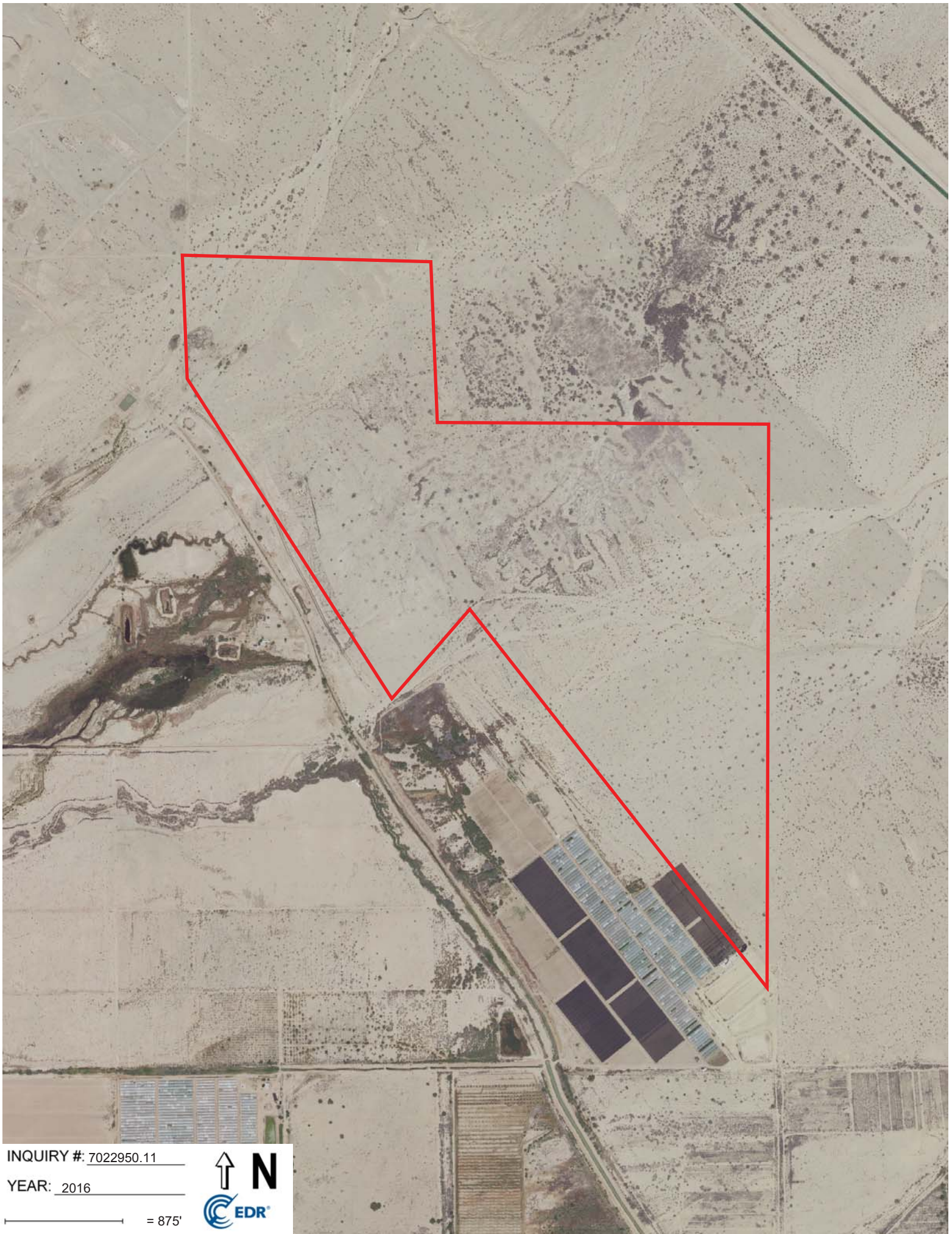

INQUIRY #: 7022950.11

YEAR: 2016

— = 875'



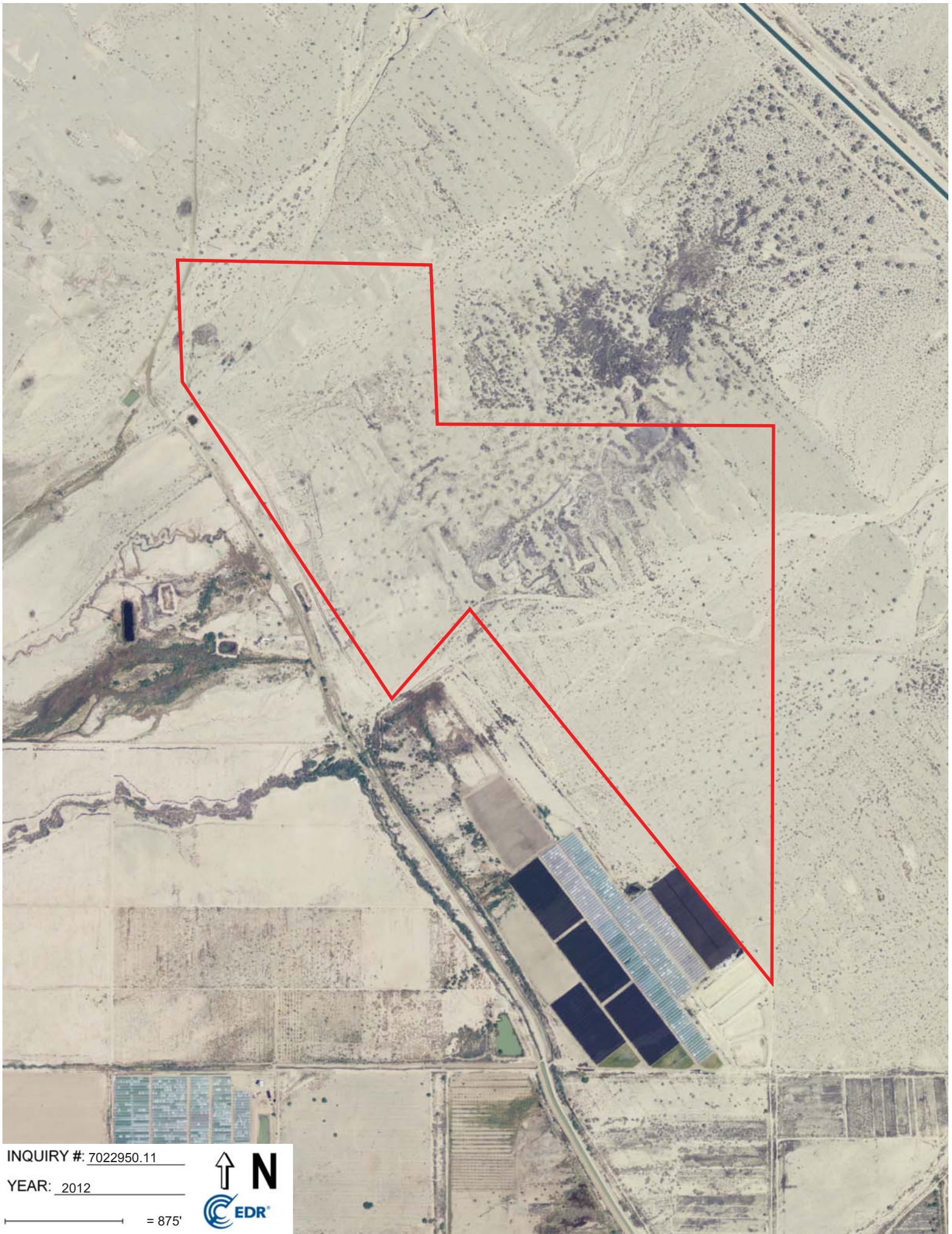

INQUIRY #: 7022950.11

YEAR: 2012

— = 875'



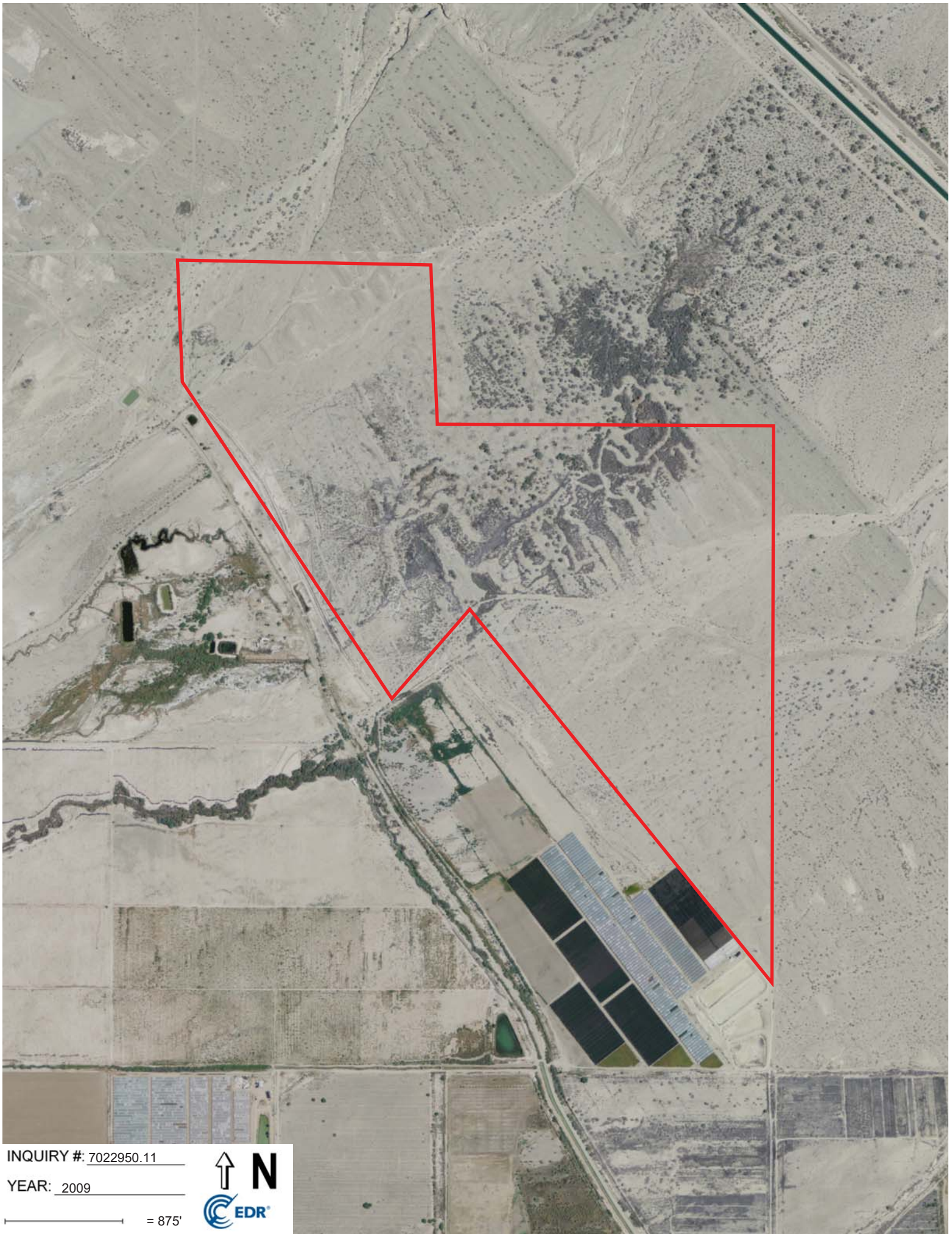

INQUIRY #: 7022950.11

YEAR: 2009

— = 875'



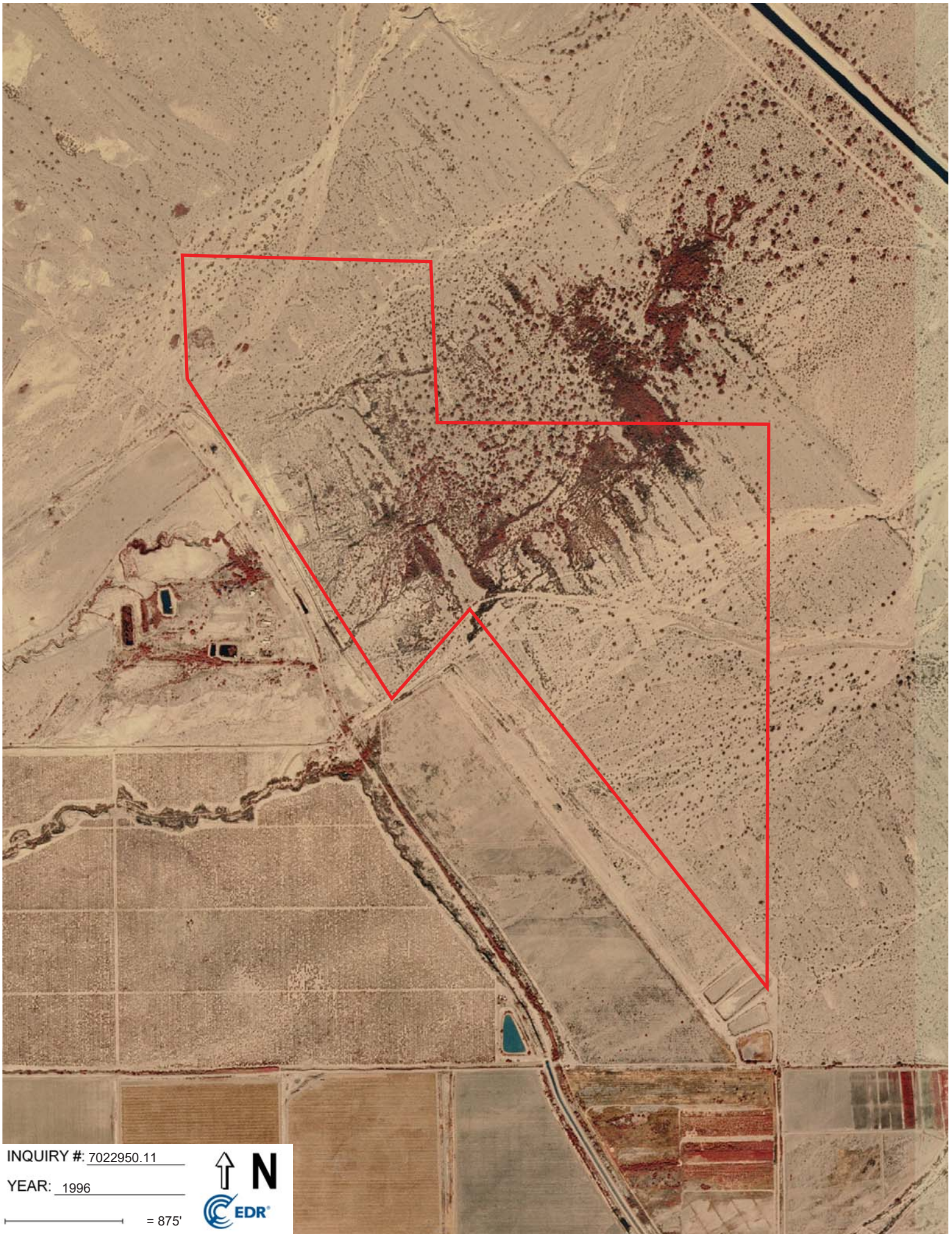

INQUIRY #: 7022950.11

YEAR: 1996

— = 875'



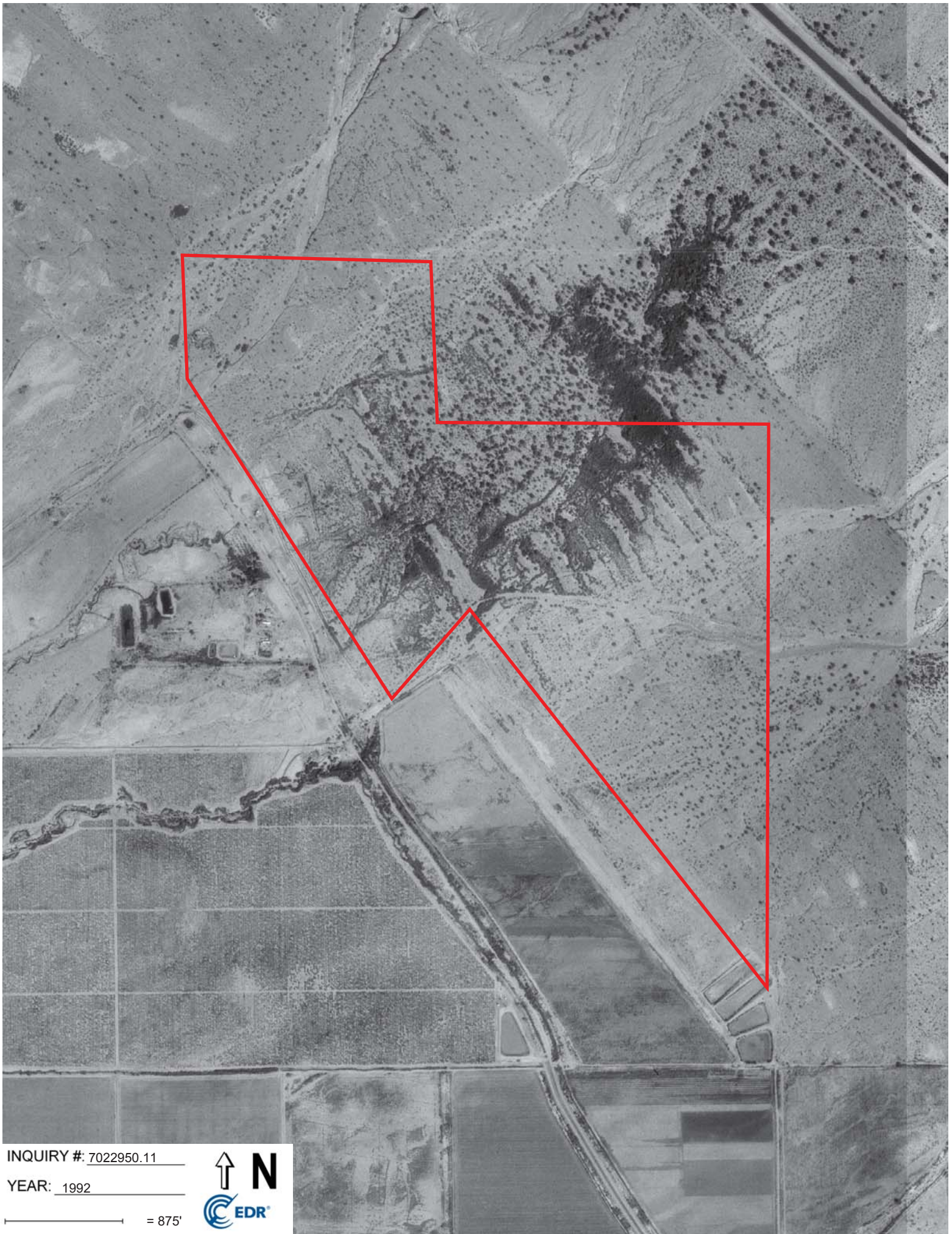

INQUIRY #: 7022950.11

YEAR: 1992

— = 875'





INQUIRY #: 7022950.11

YEAR: 1985

— = 875'



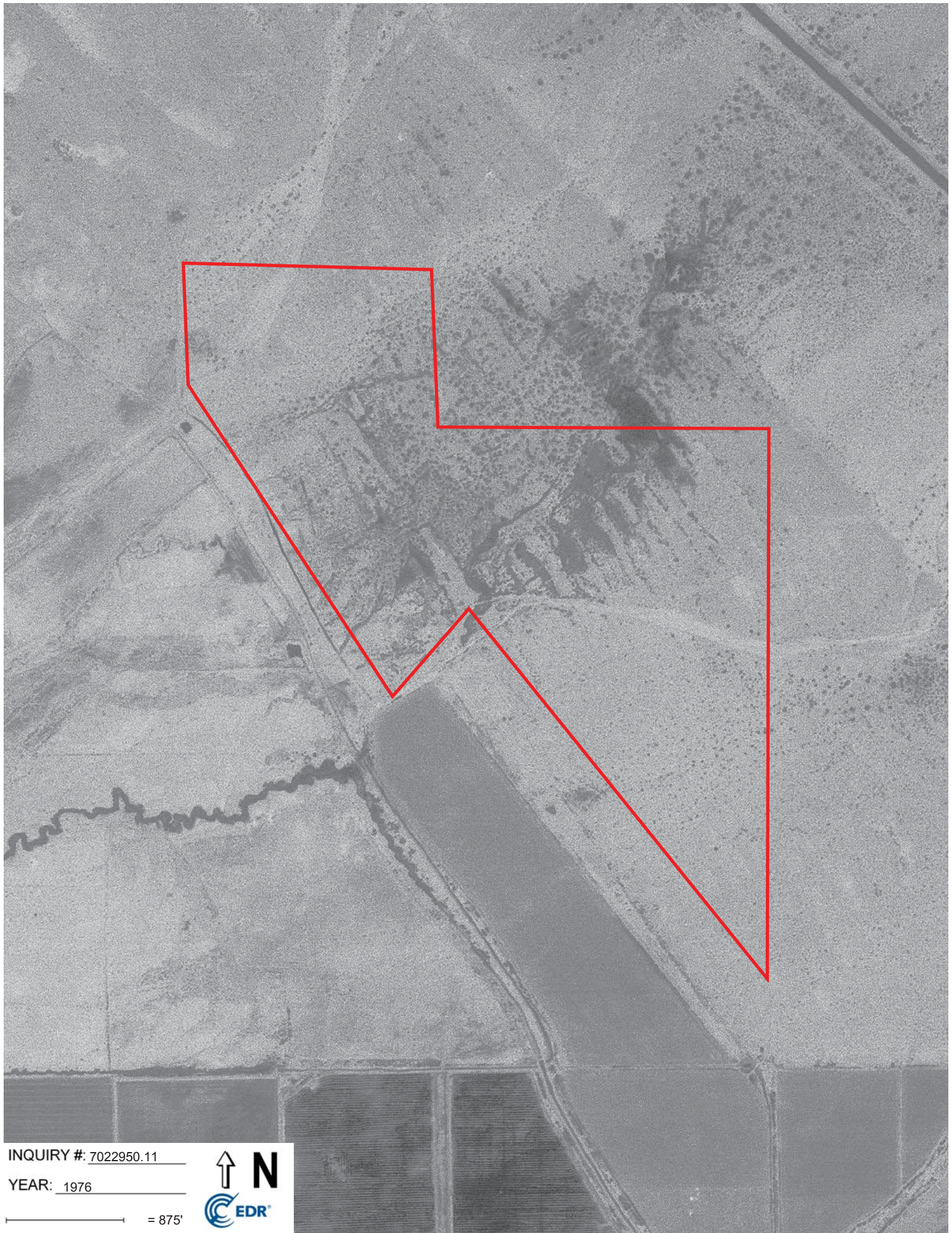

INQUIRY #: 7022950.11

YEAR: 1976

— = 875'





INQUIRY #: 7022950.11

YEAR: 1953

— = 875'



18-49

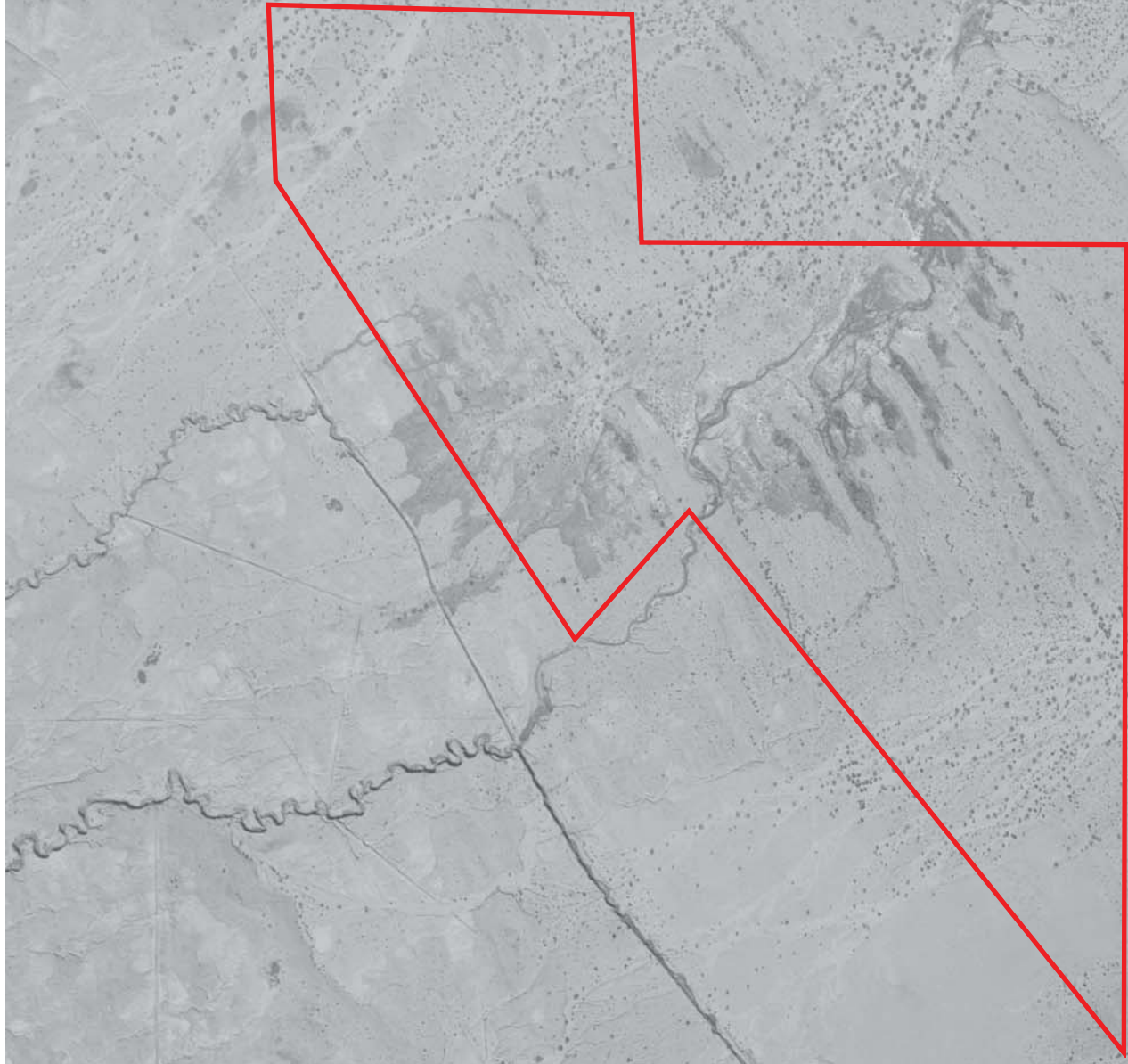

INQUIRY #: 7022950.11

YEAR: 1949

— = 875'



13-ABN 5- 45



INQUIRY #: 7022950.11
YEAR: 1937



— = 875'

APPENDIX D

Northstar 1 Solar Project
EHL Canal and Niland Lateral 6
Calipatria, CA 92233

Inquiry Number: 7022950.4

June 17, 2022

EDR Historical Topo Map Report

with QuadMatch™



6 Armstrong Road, 4th floor
Shelton, CT 06484
Toll Free: 800.352.0050
www.edrnet.com

EDR Historical Topo Map Report

06/17/22

Site Name:

Northstar 1 Solar Project
EHL Canal and Niland Lateral (EHL)
Calipatria, CA 92233
EDR Inquiry # 7022950.4

Client Name:

GS Lyon Consultants
780 N. Fourth Street
El Centro, CA 92243
Contact: Steven Williams



EDR Topographic Map Library has been searched by EDR and maps covering the target property location as provided by GS Lyon Consultants were identified for the years listed below. EDR's Historical Topo Map Report is designed to assist professionals in evaluating potential liability on a target property resulting from past activities. EDR's Historical Topo Map Report includes a search of a collection of public and private color historical topographic maps, dating back to the late 1800s.

Search Results:**Coordinates:**

P.O.#	GS2219	Latitude:	33.333838 33° 20' 2" North
Project:	NorthStar 1 Solar Project	Longitude:	-115.570058 -115° 34' 12" West
		UTM Zone:	Zone 11 North
		UTM X Meters:	633079.42
		UTM Y Meters:	3689209.92
		Elevation:	-31.00' below sea level

Maps Provided:

2018	1944
2015	1940
2012	
2002	
1995	
1976	
1956	
1947	

Disclaimer - Copyright and Trademark Notice

This Report contains certain information obtained from a variety of public and other sources reasonably available to Environmental Data Resources, Inc. It cannot be concluded from this Report that coverage information for the target and surrounding properties does not exist from other sources. NO WARRANTY EXPRESSED OR IMPLIED, IS MADE WHATSOEVER IN CONNECTION WITH THIS REPORT. ENVIRONMENTAL DATA RESOURCES, INC. SPECIFICALLY DISCLAIMS THE MAKING OF ANY SUCH WARRANTIES, INCLUDING WITHOUT LIMITATION, MERCHANTABILITY OR FITNESS FOR A PARTICULAR USE OR PURPOSE. ALL RISK IS ASSUMED BY THE USER. IN NO EVENT SHALL ENVIRONMENTAL DATA RESOURCES, INC. BE LIABLE TO ANYONE, WHETHER ARISING OUT OF ERRORS OR OMISSIONS, NEGLIGENCE, ACCIDENT OR ANY OTHER CAUSE, FOR ANY LOSS OF DAMAGE, INCLUDING, WITHOUT LIMITATION, SPECIAL, INCIDENTAL, CONSEQUENTIAL, OR EXEMPLARY DAMAGES. ANY LIABILITY ON THE PART OF ENVIRONMENTAL DATA RESOURCES, INC. IS STRICTLY LIMITED TO A REFUND OF THE AMOUNT PAID FOR THIS REPORT. Purchaser accepts this Report "AS IS". Any analyses, estimates, ratings, environmental risk levels or risk codes provided in this Report are provided for illustrative purposes only, and are not intended to provide, nor should they be interpreted as providing any facts regarding, or prediction or forecast of, any environmental risk for any property. Only a Phase I Environmental Site Assessment performed by an environmental professional can provide information regarding the environmental risk for any property. Additionally, the information provided in this Report is not to be construed as legal advice.

Copyright 2022 by Environmental Data Resources, Inc. All rights reserved. Reproduction in any media or format, in whole or in part, of any report or map of Environmental Data Resources, Inc., or its affiliates, is prohibited without prior written permission.

EDR and its logos (including Sanborn and Sanborn Map) are trademarks of Environmental Data Resources, Inc. or its affiliates. All other trademarks used herein are the property of their respective owners.

Topo Sheet Key

This EDR Topo Map Report is based upon the following USGS topographic map sheets.

2018 Source Sheets



Wister

7.5-minute, 24000

2015 Source Sheets



Wister

7.5-minute, 24000

2012 Source Sheets



Wister

7.5-minute, 24000

2002 Source Sheets

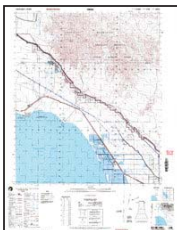

Frink

15-minute, 50000

Topo Sheet Key

This EDR Topo Map Report is based upon the following USGS topographic map sheets.

1995 Source Sheets



Wister

7.5-minute, 24000
Aerial Photo Revised 1992

1976 Source Sheets



Wister

7.5-minute, 24000
Aerial Photo Revised 1953

1956 Source Sheets



Wister

7.5-minute, 24000
Aerial Photo Revised 1953

1947 Source Sheets

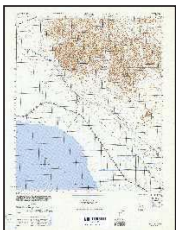

FRINK

15-minute, 50000

Topo Sheet Key

This EDR Topo Map Report is based upon the following USGS topographic map sheets.

1944 Source Sheets



Frink

15-minute, 62500
Aerial Photo Revised 1940

1940 Source Sheets



Frink

15-minute, 62500
Aerial Photo Revised 1940

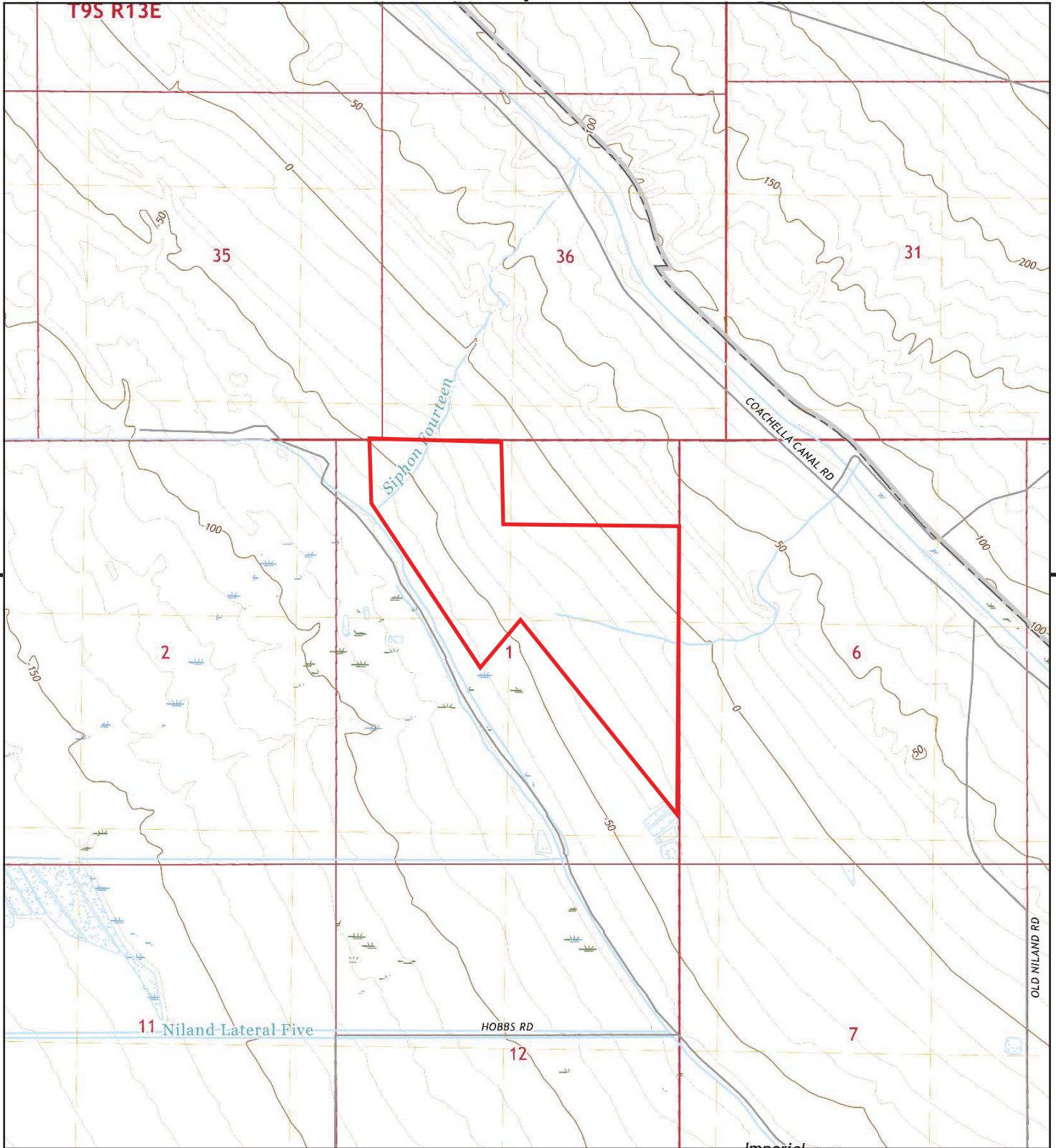

This report includes information from the following map sheet(s).

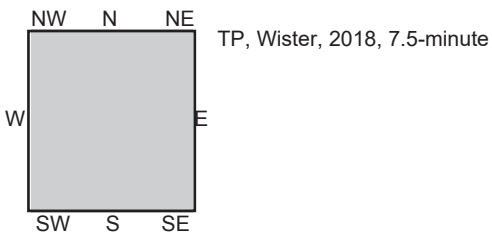
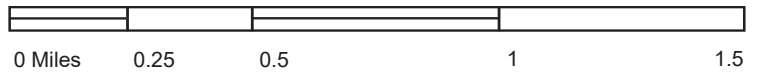

SITE NAME: Northstar 1 Solar Project
 ADDRESS: EHL Canal and Niland Lateral 6
 Calipatria, CA 92233
 CLIENT: GS Lyon Consultants



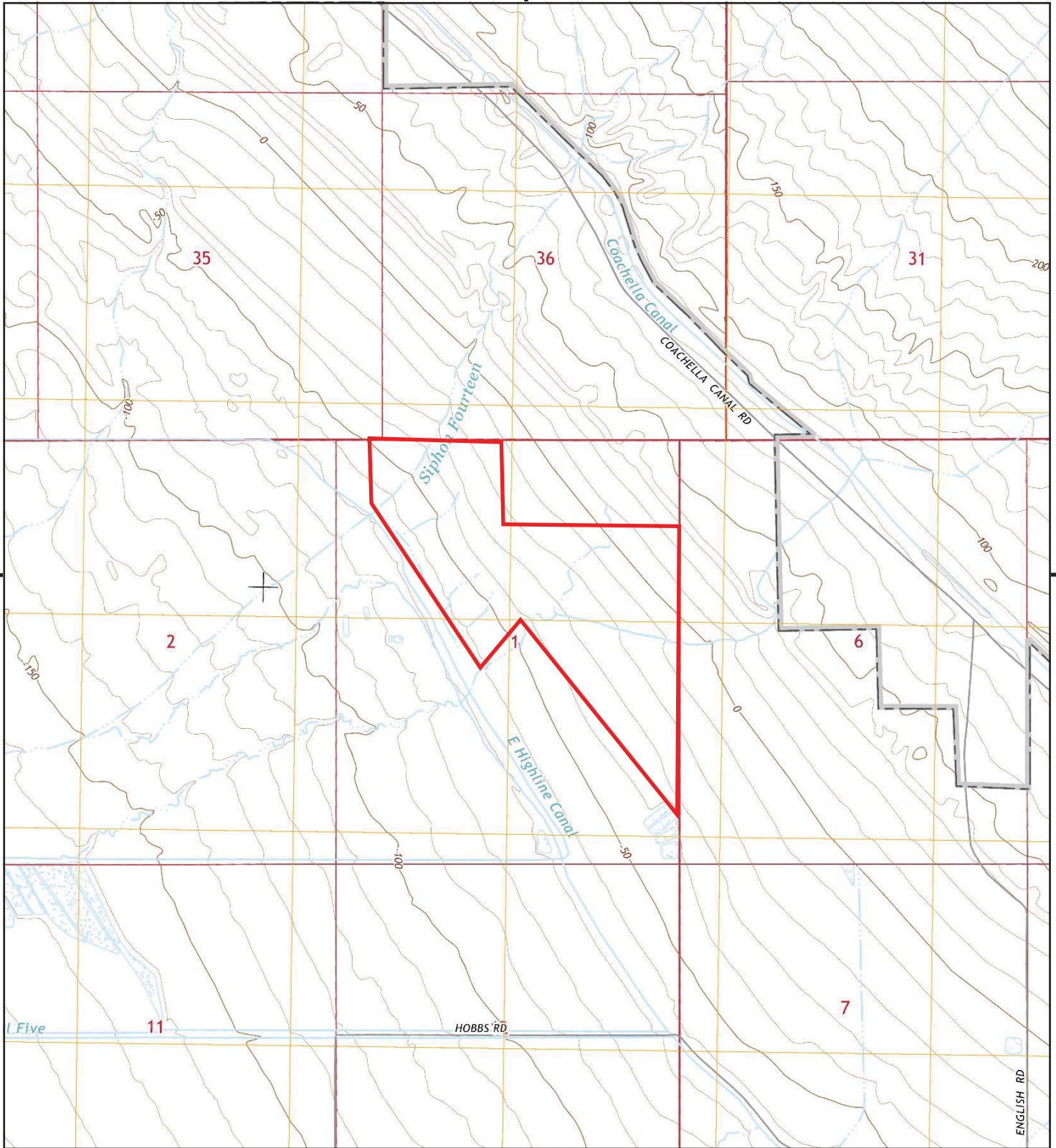

This report includes information from the following map sheet(s).

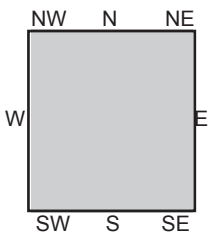
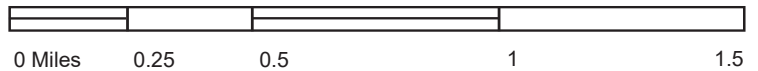

TP, Wister, 2015, 7.5-minute

SITE NAME: Northstar 1 Solar Project
ADDRESS: EHL Canal and Niland Lateral 6
 Calipatria, CA 92233
CLIENT: GS Lyon Consultants



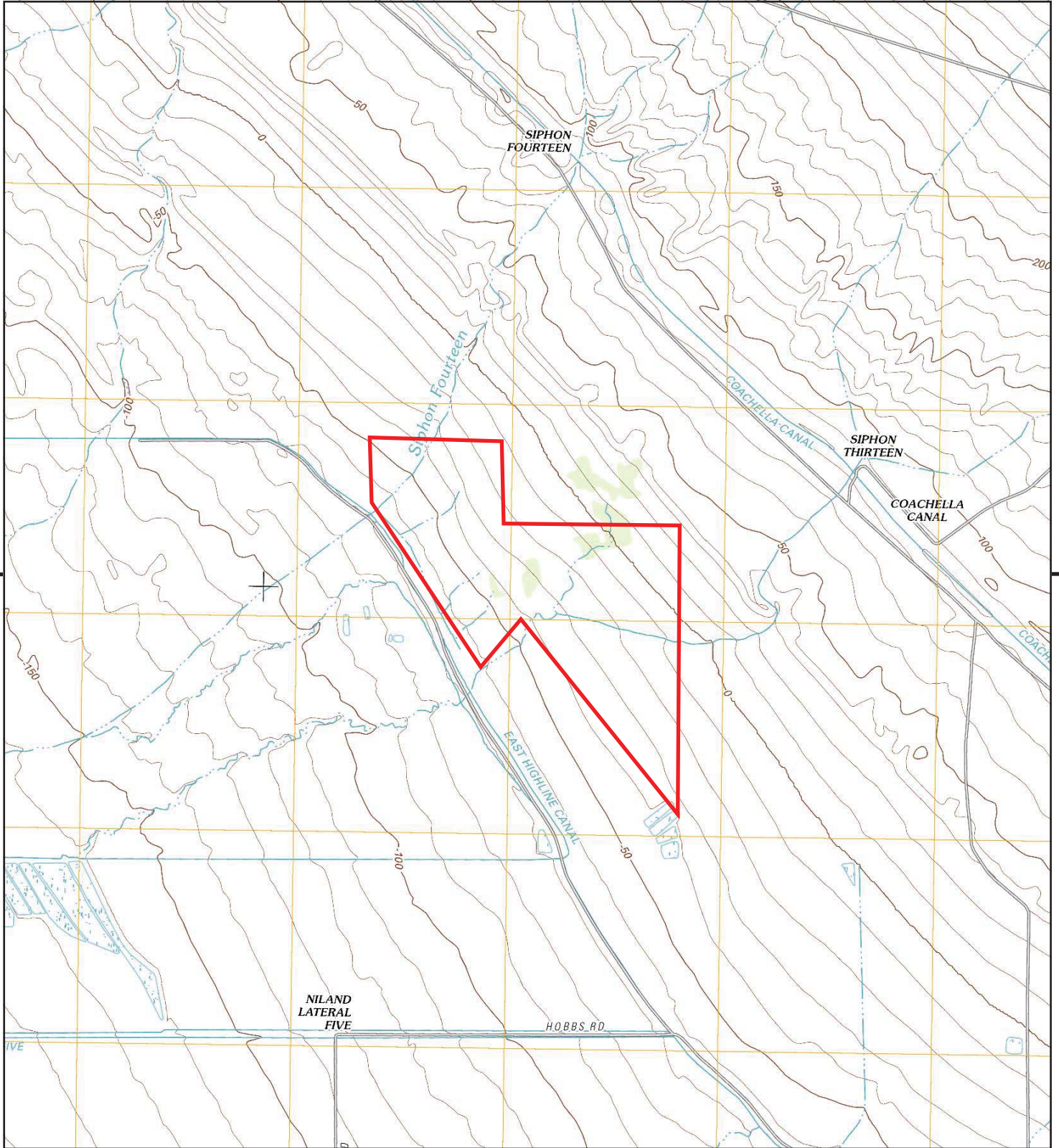

This report includes information from the following map sheet(s).

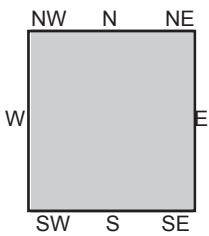
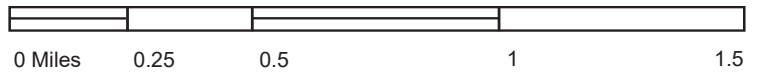

TP, Wister, 2012, 7.5-minute

SITE NAME: Northstar 1 Solar Project
ADDRESS: EHL Canal and Niland Lateral 6
Calipatria, CA 92233
CLIENT: GS Lyon Consultants



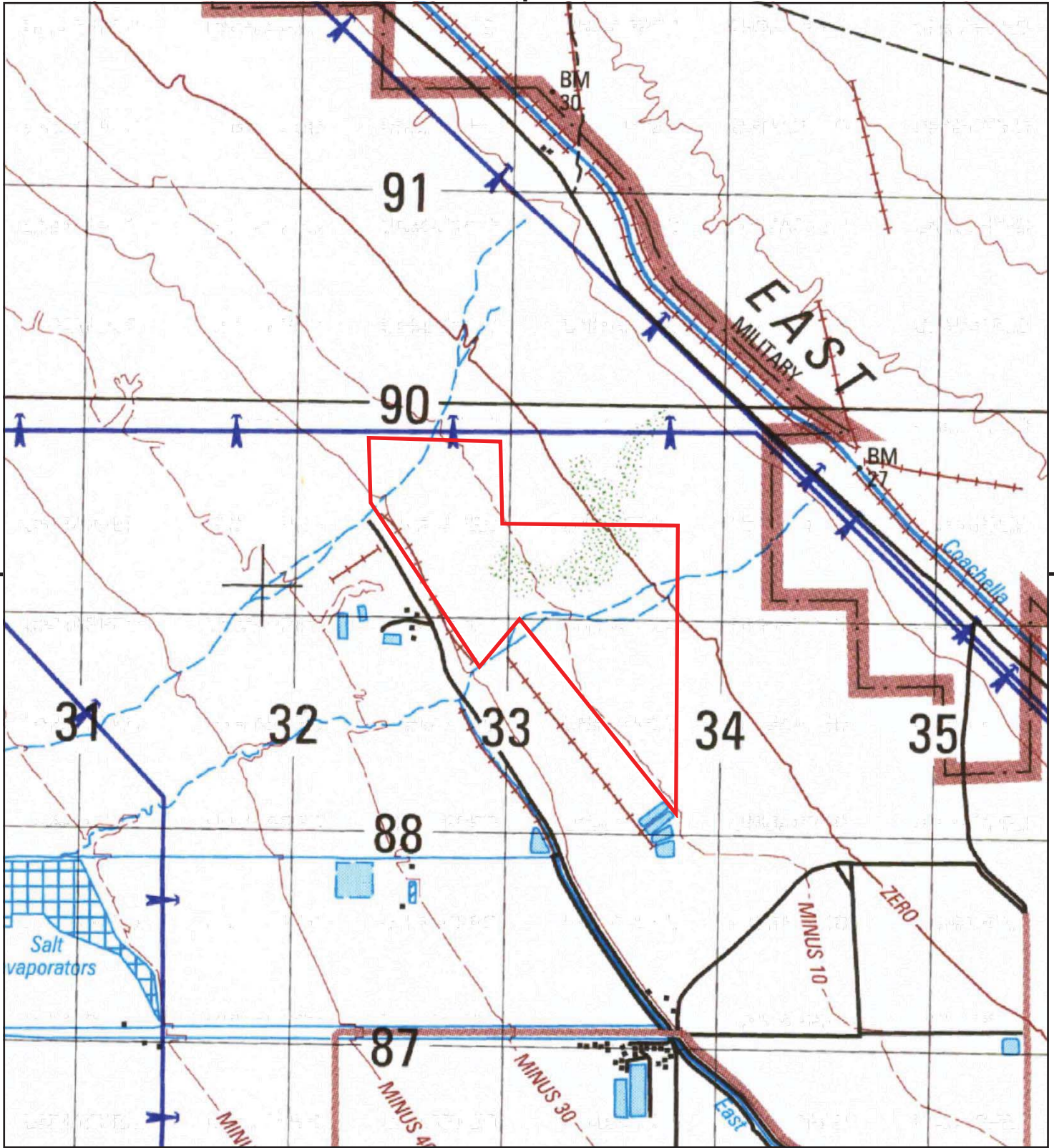

This report includes information from the following map sheet(s).

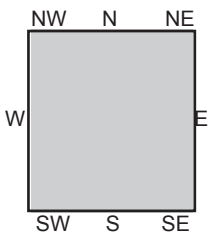
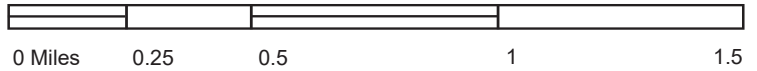

TP, Frink, 2002, 15-minute

SITE NAME: Northstar 1 Solar Project
ADDRESS: EHL Canal and Niland Lateral 6
Calipatria, CA 92233
CLIENT: GS Lyon Consultants



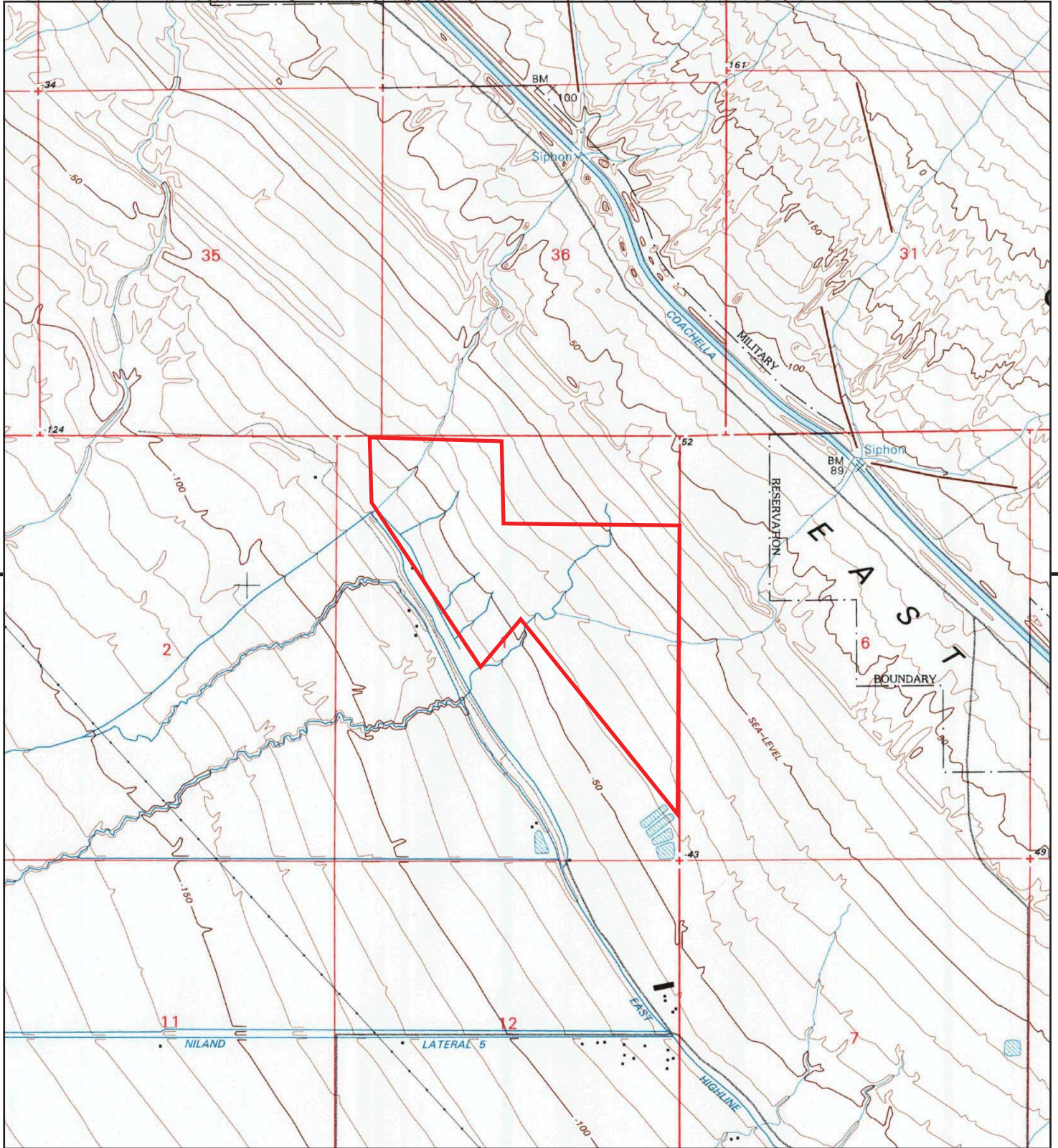

This report includes information from the following map sheet(s).

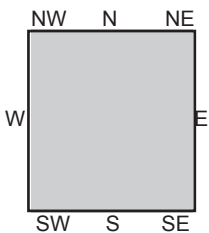
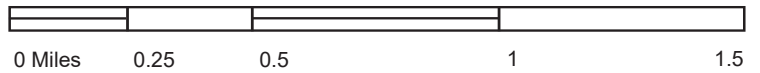

TP, Wister, 1995, 7.5-minute

SITE NAME: Northstar 1 Solar Project
ADDRESS: EHL Canal and Niland Lateral 6
 Calipatria, CA 92233
CLIENT: GS Lyon Consultants



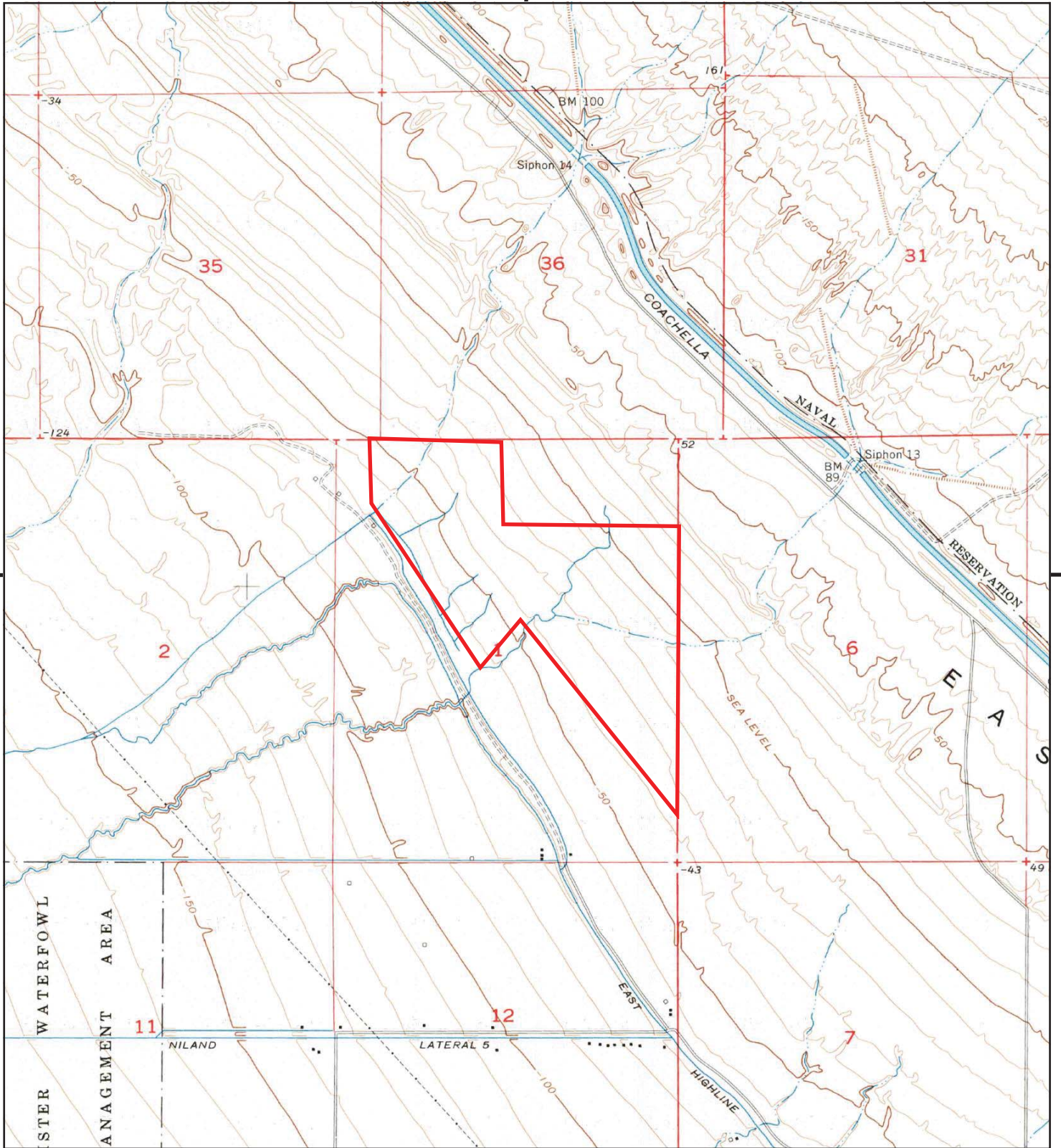

This report includes information from the following map sheet(s).

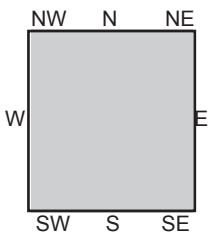
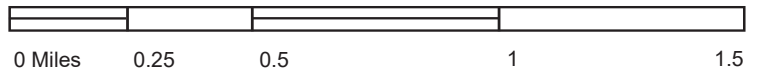

TP, Wister, 1976, 7.5-minute

SITE NAME: Northstar 1 Solar Project
ADDRESS: EHL Canal and Niland Lateral 6
 Calipatria, CA 92233
CLIENT: GS Lyon Consultants



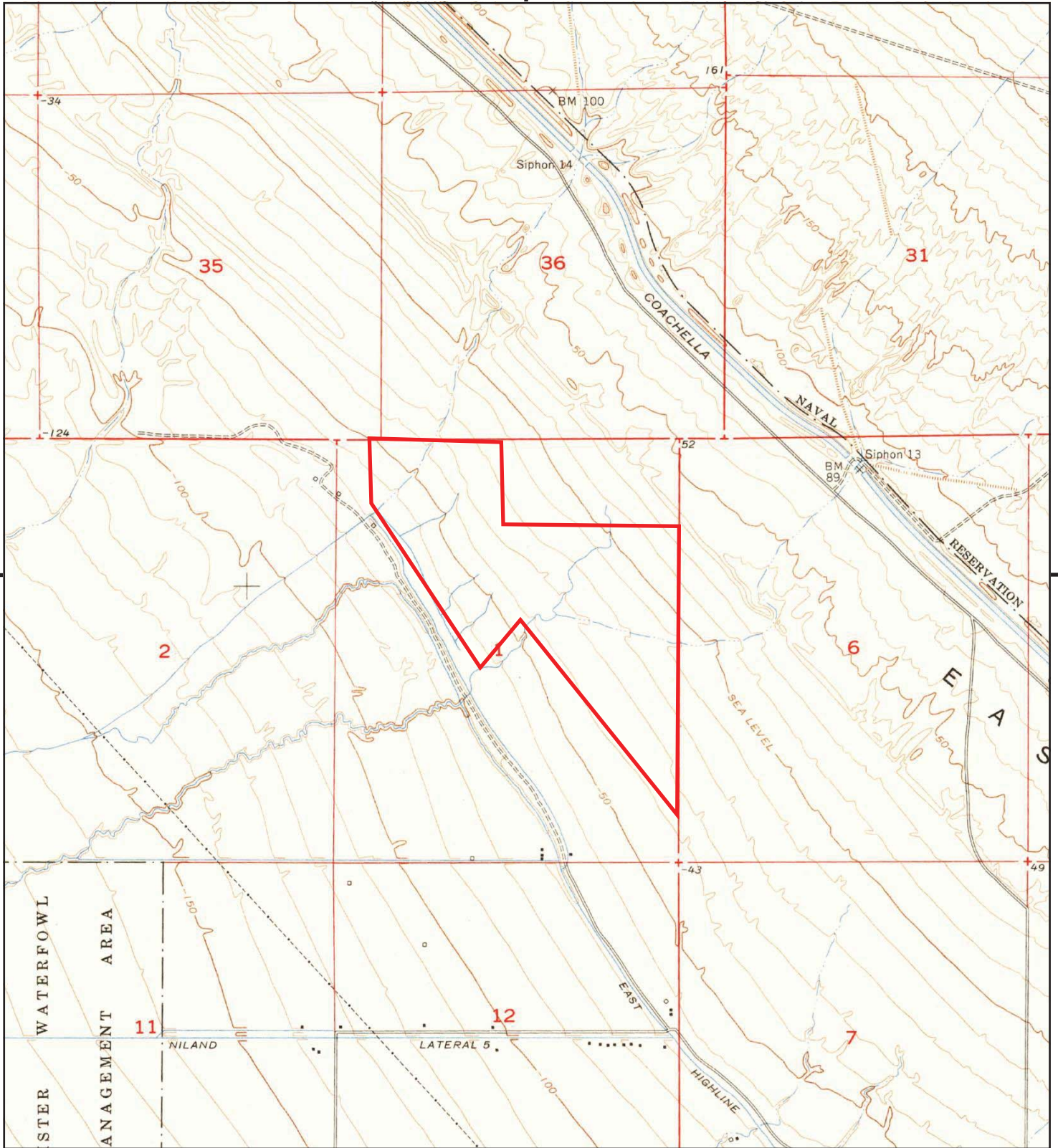

This report includes information from the following map sheet(s).

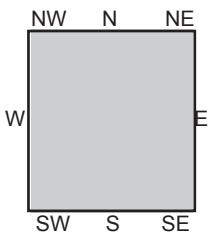
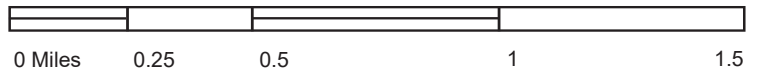

TP, Wister, 1956, 7.5-minute

SITE NAME: Northstar 1 Solar Project
ADDRESS: EHL Canal and Niland Lateral 6
 Calipatria, CA 92233
CLIENT: GS Lyon Consultants



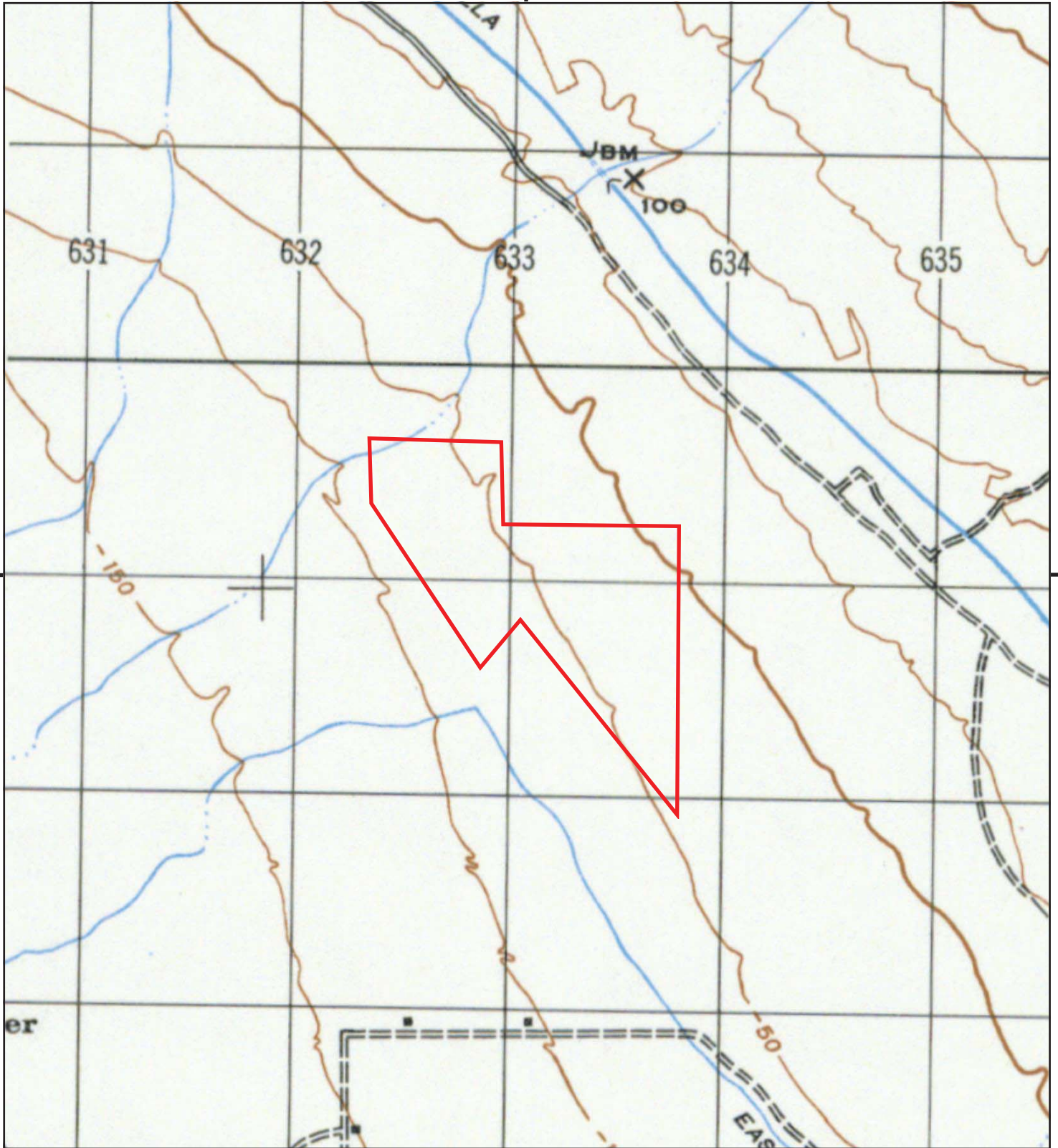

This report includes information from the following map sheet(s).

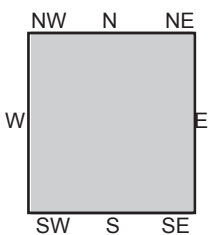
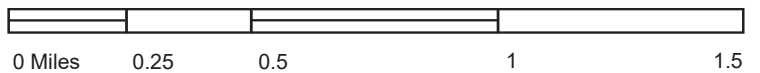

TP, FRINK, 1947, 15-minute

SITE NAME: Northstar 1 Solar Project
ADDRESS: EHL Canal and Niland Lateral 6
Calipatria, CA 92233
CLIENT: GS Lyon Consultants



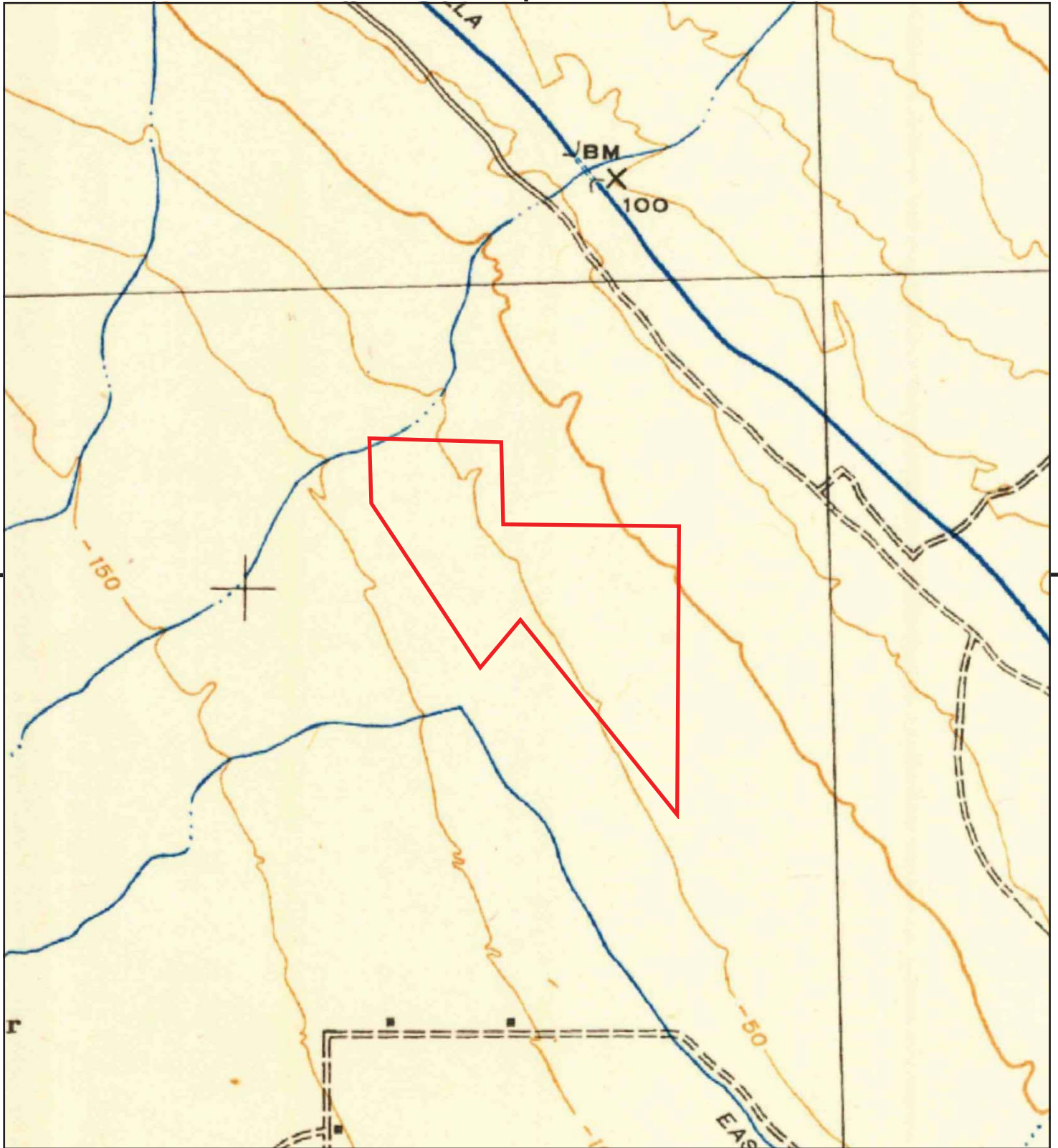

This report includes information from the following map sheet(s).

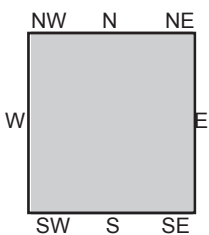
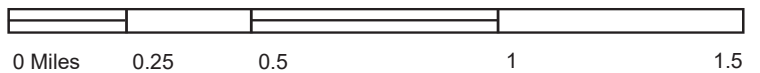

TP, Frink, 1944, 15-minute

SITE NAME: Northstar 1 Solar Project
ADDRESS: EHL Canal and Niland Lateral 6
Calipatria, CA 92233
CLIENT: GS Lyon Consultants



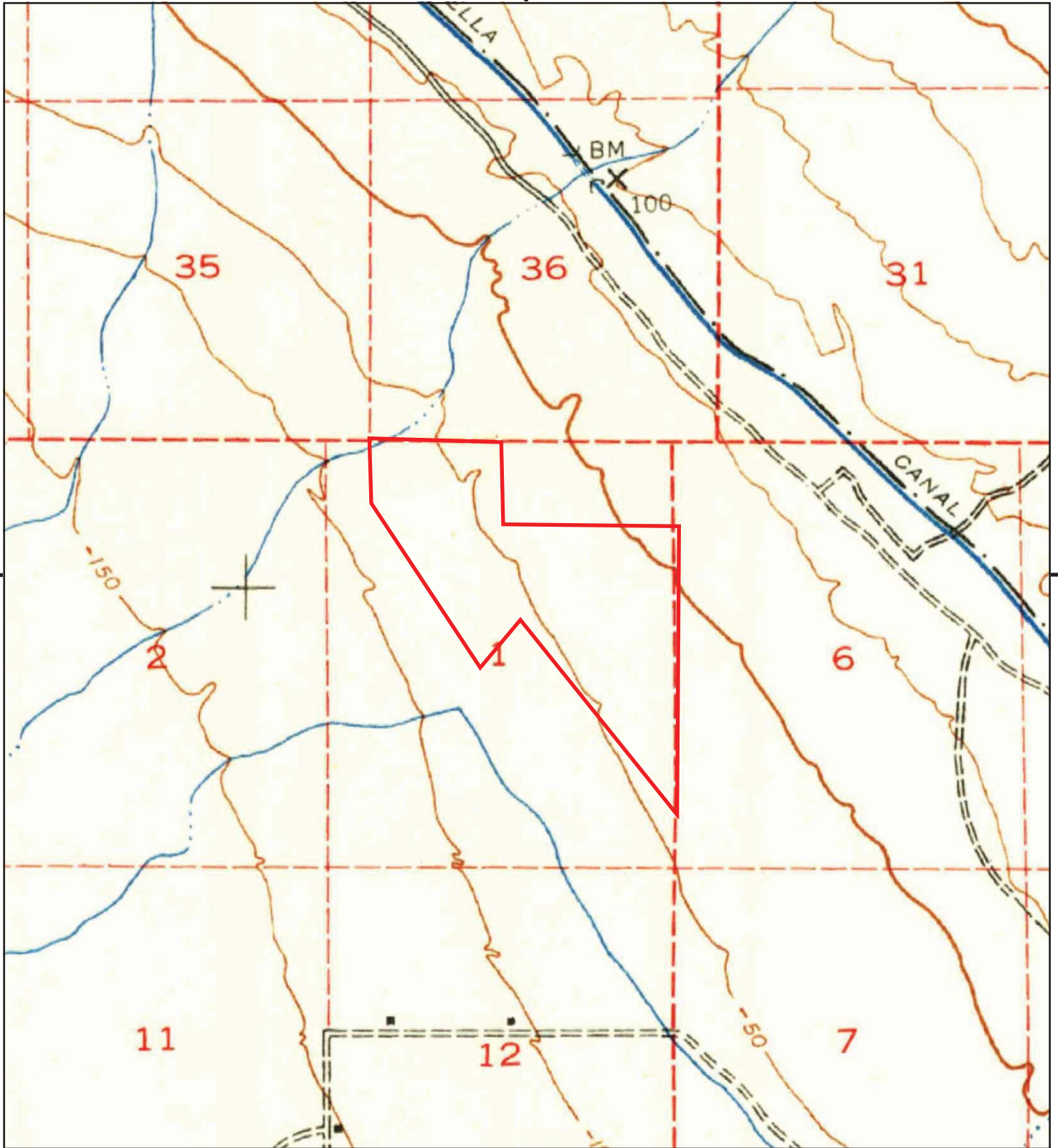

This report includes information from the following map sheet(s).

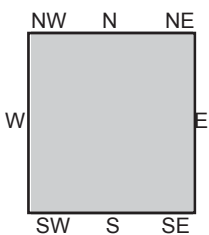
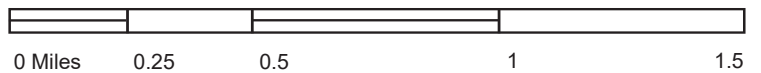

TP, Frink, 1940, 15-minute

SITE NAME: Northstar 1 Solar Project
ADDRESS: EHL Canal and Niland Lateral 6
Calipatria, CA 92233
CLIENT: GS Lyon Consultants



APPENDIX E

Northstar 1 Solar Project
EHL Canal and Niland Lateral 6
Calipatria, CA 92233

Inquiry Number: 7022950.3

June 17, 2022

Certified Sanborn® Map Report



6 Armstrong Road, 4th floor
Shelton, CT 06484
Toll Free: 800.352.0050
www.edrnet.com

Certified Sanborn® Map Report

06/17/22

Site Name:

Northstar 1 Solar Project
EHL Canal and Niland Lateral (EHL)
Calipatria, CA 92233
EDR Inquiry # 7022950.3

Client Name:

GS Lyon Consultants
780 N. Fourth Street
El Centro, CA 92243
Contact: Steven Williams



The Sanborn Library has been searched by EDR and maps covering the target property location as provided by GS Lyon Consultants were identified for the years listed below. The Sanborn Library is the largest, most complete collection of fire insurance maps. The collection includes maps from Sanborn, Bromley, Perris & Browne, Hopkins, Barlow, and others. Only Environmental Data Resources Inc. (EDR) is authorized to grant rights for commercial reproduction of maps by the Sanborn Library LLC, the copyright holder for the collection. Results can be authenticated by visiting www.edrnet.com/sanborn.

The Sanborn Library is continually enhanced with newly identified map archives. This report accesses all maps in the collection as of the day this report was generated.

Certified Sanborn Results:

Certification # CADD-4296-957D
PO # GS2219
Project NorthStar 1 Solar Project

UNMAPPED PROPERTY

This report certifies that the complete holdings of the Sanborn Library, LLC collection have been searched based on client supplied target property information, and fire insurance maps covering the target property were not found.



Sanborn® Library search results

Certification #: CADD-4296-957D

The Sanborn Library includes more than 1.2 million fire insurance maps from Sanborn, Bromley, Perris & Browne, Hopkins, Barlow and others which track historical property usage in approximately 12,000 American cities and towns. Collections searched:

- Library of Congress
- University Publications of America
- EDR Private Collection

The Sanborn Library LLC Since 1866™

Limited Permission To Make Copies

GS Lyon Consultants (the client) is permitted to make up to FIVE photocopies of this Sanborn Map transmittal and each fire insurance map accompanying this report solely for the limited use of its customer. No one other than the client is authorized to make copies. Upon request made directly to an EDR Account Executive, the client may be permitted to make a limited number of additional photocopies. This permission is conditioned upon compliance by the client, its customer and their agents with EDR's copyright policy; a copy of which is available upon request.

Disclaimer - Copyright and Trademark Notice

This Report contains certain information obtained from a variety of public and other sources reasonably available to Environmental Data Resources, Inc. It cannot be concluded from this Report that coverage information for the target and surrounding properties does not exist from other sources. NO WARRANTY EXPRESSED OR IMPLIED, IS MADE WHATSOEVER IN CONNECTION WITH THIS REPORT. ENVIRONMENTAL DATA RESOURCES, INC. SPECIFICALLY DISCLAIMS THE MAKING OF ANY SUCH WARRANTIES, INCLUDING WITHOUT LIMITATION, MERCHANTABILITY OR FITNESS FOR A PARTICULAR USE OR PURPOSE. ALL RISK IS ASSUMED BY THE USER. IN NO EVENT SHALL ENVIRONMENTAL DATA RESOURCES, INC. BE LIABLE TO ANYONE, WHETHER ARISING OUT OF ERRORS OR OMISSIONS, NEGLIGENCE, ACCIDENT OR ANY OTHER CAUSE, FOR ANY LOSS OF DAMAGE, INCLUDING, WITHOUT LIMITATION, SPECIAL, INCIDENTAL, CONSEQUENTIAL, OR EXEMPLARY DAMAGES. ANY LIABILITY ON THE PART OF ENVIRONMENTAL DATA RESOURCES, INC. IS STRICTLY LIMITED TO A REFUND OF THE AMOUNT PAID FOR THIS REPORT. Purchaser accepts this Report "AS IS". Any analyses, estimates, ratings, environmental risk levels or risk codes provided in this Report are provided for illustrative purposes only, and are not intended to provide, nor should they be interpreted as providing any facts regarding, or prediction or forecast of, any environmental risk for any property. Only a Phase I Environmental Site Assessment performed by an environmental professional can provide information regarding the environmental risk for any property. Additionally, the information provided in this Report is not to be construed as legal advice. Copyright 2022 by Environmental Data Resources, Inc. All rights reserved. Reproduction in any media or format, in whole or in part, of any report or map of Environmental Data Resources, Inc., or its affiliates, is prohibited without prior written permission.

EDR and its logos (including Sanborn and Sanborn Map) are trademarks of Environmental Data Resources, Inc. or its affiliates. All other trademarks used herein are the property of their respective owners.

APPENDIX F

Northstar 1 Solar Project
EHL Canal and Niland Lateral 6
Calipatria, CA 92233

Inquiry Number: 7022950.2s
June 17, 2022

The EDR Radius Map™ Report with GeoCheck®



6 Armstrong Road, 4th floor
Shelton, CT 06484
Toll Free: 800.352.0050
www.edrnet.com

TABLE OF CONTENTS

<u>SECTION</u>	<u>PAGE</u>
Executive Summary	ES1
Overview Map	2
Detail Map	3
Map Findings Summary	4
Map Findings	9
Orphan Summary	10
Government Records Searched/Data Currency Tracking	GR-1
 <u>GEOCHECK ADDENDUM</u>	
Physical Setting Source Addendum	A-1
Physical Setting Source Summary	A-2
Physical Setting SSURGO Soil Map	A-5
Physical Setting Source Map	A-8
Physical Setting Source Map Findings	A-10
Physical Setting Source Records Searched	PSGR-1

Thank you for your business.
Please contact EDR at 1-800-352-0050
with any questions or comments.

Disclaimer - Copyright and Trademark Notice

This Report contains certain information obtained from a variety of public and other sources reasonably available to Environmental Data Resources, Inc. It cannot be concluded from this Report that coverage information for the target and surrounding properties does not exist from other sources. **NO WARRANTY EXPRESSED OR IMPLIED, IS MADE WHATSOEVER IN CONNECTION WITH THIS REPORT. ENVIRONMENTAL DATA RESOURCES, INC. SPECIFICALLY DISCLAIMS THE MAKING OF ANY SUCH WARRANTIES, INCLUDING WITHOUT LIMITATION, MERCHANTABILITY OR FITNESS FOR A PARTICULAR USE OR PURPOSE. ALL RISK IS ASSUMED BY THE USER. IN NO EVENT SHALL ENVIRONMENTAL DATA RESOURCES, INC. BE LIABLE TO ANYONE, WHETHER ARISING OUT OF ERRORS OR OMISSIONS, NEGLIGENCE, ACCIDENT OR ANY OTHER CAUSE, FOR ANY LOSS OF DAMAGE, INCLUDING, WITHOUT LIMITATION, SPECIAL, INCIDENTAL, CONSEQUENTIAL, OR EXEMPLARY DAMAGES. ANY LIABILITY ON THE PART OF ENVIRONMENTAL DATA RESOURCES, INC. IS STRICTLY LIMITED TO A REFUND OF THE AMOUNT PAID FOR THIS REPORT.** Purchaser accepts this Report "AS IS". Any analyses, estimates, ratings, environmental risk levels or risk codes provided in this Report are provided for illustrative purposes only, and are not intended to provide, nor should they be interpreted as providing any facts regarding, or prediction or forecast of, any environmental risk for any property. Only a Phase I Environmental Site Assessment performed by an environmental professional can provide information regarding the environmental risk for any property. Additionally, the information provided in this Report is not to be construed as legal advice.

Copyright 2020 by Environmental Data Resources, Inc. All rights reserved. Reproduction in any media or format, in whole or in part, of any report or map of Environmental Data Resources, Inc., or its affiliates, is prohibited without prior written permission.

EDR and its logos (including Sanborn and Sanborn Map) are trademarks of Environmental Data Resources, Inc. or its affiliates. All other trademarks used herein are the property of their respective owners.

EXECUTIVE SUMMARY

A search of available environmental records was conducted by Environmental Data Resources, Inc (EDR). The report was designed to assist parties seeking to meet the search requirements of EPA's Standards and Practices for All Appropriate Inquiries (40 CFR Part 312), the ASTM Standard Practice for Environmental Site Assessments (E1527-21), the ASTM Standard Practice for Environmental Site Assessments for Forestland or Rural Property (E 2247-16), the ASTM Standard Practice for Limited Environmental Due Diligence: Transaction Screen Process (E 1528-14) or custom requirements developed for the evaluation of environmental risk associated with a parcel of real estate.

TARGET PROPERTY INFORMATION

ADDRESS

EHL CANAL AND NILAND LATERAL 6
CALIPATRIA, CA 92233

COORDINATES

Latitude (North): 33.3338380 - 33° 20' 1.81"
Longitude (West): 115.5700580 - 115° 34' 12.20"
Universal Transverse Mercator: Zone 11
UTM X (Meters): 633082.4
UTM Y (Meters): 3689017.8
Elevation: 31 ft. below sea level

USGS TOPOGRAPHIC MAP ASSOCIATED WITH TARGET PROPERTY

Target Property Map: 11994450 WISTER, CA
Version Date: 2018

AERIAL PHOTOGRAPHY IN THIS REPORT

Portions of Photo from: 20140606
Source: USDA

MAPPED SITES SUMMARY

Target Property Address:
EHL CANAL AND NILAND LATERAL 6
CALIPATRIA, CA 92233

Click on Map ID to see full detail.

MAP ID	SITE NAME	ADDRESS	DATABASE ACRONYMS	RELATIVE ELEVATION	DIST (ft. & mi.) DIRECTION
Reg	CHOC MT AIR GNRV RNG		DOD	Same	2542, 0.481, NE

EXECUTIVE SUMMARY

TARGET PROPERTY SEARCH RESULTS

The target property was not listed in any of the databases searched by EDR.

DATABASES WITH NO MAPPED SITES

No mapped sites were found in EDR's search of available ("reasonably ascertainable ") government records either on the target property or within the search radius around the target property for the following databases:

STANDARD ENVIRONMENTAL RECORDS

Lists of Federal NPL (Superfund) sites

NPL..... National Priority List
Proposed NPL..... Proposed National Priority List Sites
NPL LIENS..... Federal Superfund Liens

Lists of Federal Delisted NPL sites

Delisted NPL..... National Priority List Deletions

Lists of Federal sites subject to CERCLA removals and CERCLA orders

FEDERAL FACILITY..... Federal Facility Site Information listing
SEMS..... Superfund Enterprise Management System

Lists of Federal CERCLA sites with NFRAP

SEMS-ARCHIVE..... Superfund Enterprise Management System Archive

Lists of Federal RCRA facilities undergoing Corrective Action

CORRACTS..... Corrective Action Report

Lists of Federal RCRA TSD facilities

RCRA-TSDF..... RCRA - Treatment, Storage and Disposal

Lists of Federal RCRA generators

RCRA-LQG..... RCRA - Large Quantity Generators
RCRA-SQG..... RCRA - Small Quantity Generators
RCRA-VSQG..... RCRA - Very Small Quantity Generators (Formerly Conditionally Exempt Small Quantity Generators)

Federal institutional controls / engineering controls registries

LUCIS..... Land Use Control Information System

EXECUTIVE SUMMARY

US ENG CONTROLS..... Engineering Controls Sites List
US INST CONTROLS..... Institutional Controls Sites List

Federal ERNS list

ERNS..... Emergency Response Notification System

Lists of state- and tribal (Superfund) equivalent sites

RESPONSE..... State Response Sites

Lists of state- and tribal hazardous waste facilities

ENVIROSTOR..... EnviroStor Database

Lists of state and tribal landfills and solid waste disposal facilities

SWF/LF..... Solid Waste Information System

Lists of state and tribal leaking storage tanks

LUST..... Geotracker's Leaking Underground Fuel Tank Report
INDIAN LUST..... Leaking Underground Storage Tanks on Indian Land
CPS-SLIC..... Statewide SLIC Cases

Lists of state and tribal registered storage tanks

FEMA UST..... Underground Storage Tank Listing
UST..... Active UST Facilities
AST..... Aboveground Petroleum Storage Tank Facilities
INDIAN UST..... Underground Storage Tanks on Indian Land

Lists of state and tribal voluntary cleanup sites

VCP..... Voluntary Cleanup Program Properties
INDIAN VCP..... Voluntary Cleanup Priority Listing

Lists of state and tribal brownfield sites

BROWNFIELDS..... Considered Brownfields Sites Listing

ADDITIONAL ENVIRONMENTAL RECORDS

Local Brownfield lists

US BROWNFIELDS..... A Listing of Brownfields Sites

Local Lists of Landfill / Solid Waste Disposal Sites

WMUDS/SWAT..... Waste Management Unit Database
SWRCY..... Recycler Database
HAULERS..... Registered Waste Tire Haulers Listing
INDIAN ODI..... Report on the Status of Open Dumps on Indian Lands
DEBRIS REGION 9..... Torres Martinez Reservation Illegal Dump Site Locations

EXECUTIVE SUMMARY

ODI..... Open Dump Inventory
IHS OPEN DUMPS..... Open Dumps on Indian Land

Local Lists of Hazardous waste / Contaminated Sites

US HIST CDL..... Delisted National Clandestine Laboratory Register
HIST Cal-Sites..... Historical Calsites Database
SCH..... School Property Evaluation Program
CDL..... Clandestine Drug Labs
Toxic Pits..... Toxic Pits Cleanup Act Sites
CERS HAZ WASTE..... CERS HAZ WASTE
US CDL..... National Clandestine Laboratory Register
AQUEOUS FOAM..... Former Fire Training Facility Assessments Listing
PFAS..... PFAS Contamination Site Location Listing

Local Lists of Registered Storage Tanks

SWEEPS UST..... SWEEPS UST Listing
HIST UST..... Hazardous Substance Storage Container Database
CA FID UST..... Facility Inventory Database
CERS TANKS..... California Environmental Reporting System (CERS) Tanks

Local Land Records

LIENS..... Environmental Liens Listing
LIENS 2..... CERCLA Lien Information
DEED..... Deed Restriction Listing

Records of Emergency Release Reports

HMIRS..... Hazardous Materials Information Reporting System
CHMIRS..... California Hazardous Material Incident Report System
LDS..... Land Disposal Sites Listing
MCS..... Military Cleanup Sites Listing
SPILLS 90..... SPILLS 90 data from FirstSearch

Other Ascertainable Records

RCRA NonGen / NLR..... RCRA - Non Generators / No Longer Regulated
FUDS..... Formerly Used Defense Sites
SCRD DRYCLEANERS..... State Coalition for Remediation of Drycleaners Listing
US FIN ASSUR..... Financial Assurance Information
EPA WATCH LIST..... EPA WATCH LIST
2020 COR ACTION..... 2020 Corrective Action Program List
TSCA..... Toxic Substances Control Act
TRIS..... Toxic Chemical Release Inventory System
SSTS..... Section 7 Tracking Systems
ROD..... Records Of Decision
RMP..... Risk Management Plans
RAATS..... RCRA Administrative Action Tracking System
PRP..... Potentially Responsible Parties
PADS..... PCB Activity Database System
ICIS..... Integrated Compliance Information System
FTTS..... FIFRA/ TSCA Tracking System - FIFRA (Federal Insecticide, Fungicide, & Rodenticide Act)/TSCA (Toxic Substances Control Act)

EXECUTIVE SUMMARY

MLTS.....	Material Licensing Tracking System
COAL ASH DOE.....	Steam-Electric Plant Operation Data
COAL ASH EPA.....	Coal Combustion Residues Surface Impoundments List
PCB TRANSFORMER.....	PCB Transformer Registration Database
RADINFO.....	Radiation Information Database
HIST FTTS.....	FIFRA/TSCA Tracking System Administrative Case Listing
DOT OPS.....	Incident and Accident Data
CONSENT.....	Superfund (CERCLA) Consent Decrees
INDIAN RESERV.....	Indian Reservations
FUSRAP.....	Formerly Utilized Sites Remedial Action Program
UMTRA.....	Uranium Mill Tailings Sites
LEAD SMELTERS.....	Lead Smelter Sites
US AIRS.....	Aerometric Information Retrieval System Facility Subsystem
US MINES.....	Mines Master Index File
ABANDONED MINES.....	Abandoned Mines
FINDS.....	Facility Index System/Facility Registry System
UXO.....	Unexploded Ordnance Sites
ECHO.....	Enforcement & Compliance History Information
DOCKET HWC.....	Hazardous Waste Compliance Docket Listing
FUELS PROGRAM.....	EPA Fuels Program Registered Listing
CA BOND EXP. PLAN.....	Bond Expenditure Plan
Cortese.....	"Cortese" Hazardous Waste & Substances Sites List
CUPA Listings.....	CUPA Resources List
DRYCLEANERS.....	Cleaner Facilities
EML.....	Emissions Inventory Data
ENF.....	Enforcement Action Listing
Financial Assurance.....	Financial Assurance Information Listing
HAZNET.....	Facility and Manifest Data
ICE.....	ICE
HIST CORTESE.....	Hazardous Waste & Substance Site List
HWP.....	EnviroStor Permitted Facilities Listing
HWT.....	Registered Hazardous Waste Transporter Database
MINES.....	Mines Site Location Listing
MWMP.....	Medical Waste Management Program Listing
NPDES.....	NPDES Permits Listing
PEST LIC.....	Pesticide Regulation Licenses Listing
PROC.....	Certified Processors Database
Notify 65.....	Proposition 65 Records
UIC.....	UIC Listing
UIC GEO.....	UIC GEO (GEOTRACKER)
WASTEWATER PITS.....	Oil Wastewater Pits Listing
WDS.....	Waste Discharge System
WIP.....	Well Investigation Program Case List
MILITARY PRIV SITES.....	MILITARY PRIV SITES (GEOTRACKER)
PROJECT.....	PROJECT (GEOTRACKER)
WDR.....	Waste Discharge Requirements Listing
CIWQS.....	California Integrated Water Quality System
CERS.....	CERS
NON-CASE INFO.....	NON-CASE INFO (GEOTRACKER)
OTHER OIL GAS.....	OTHER OIL & GAS (GEOTRACKER)
PROD WATER PONDS.....	PROD WATER PONDS (GEOTRACKER)
SAMPLING POINT.....	SAMPLING POINT (GEOTRACKER)
WELL STIM PROJ.....	Well Stimulation Project (GEOTRACKER)
HWTS.....	Hazardous Waste Tracking System
MINES MRDS.....	Mineral Resources Data System

EXECUTIVE SUMMARY

EDR HIGH RISK HISTORICAL RECORDS

EDR Exclusive Records

EDR MGP..... EDR Proprietary Manufactured Gas Plants
EDR Hist Auto..... EDR Exclusive Historical Auto Stations
EDR Hist Cleaner..... EDR Exclusive Historical Cleaners

EDR RECOVERED GOVERNMENT ARCHIVES

Exclusive Recovered Govt. Archives

RGA LF..... Recovered Government Archive Solid Waste Facilities List
RGA LUST..... Recovered Government Archive Leaking Underground Storage Tank

SURROUNDING SITES: SEARCH RESULTS

Surrounding sites were identified in the following databases.

Elevations have been determined from the USGS Digital Elevation Model and should be evaluated on a relative (not an absolute) basis. Relative elevation information between sites of close proximity should be field verified. Sites with an elevation equal to or higher than the target property have been differentiated below from sites with an elevation lower than the target property.

Page numbers and map identification numbers refer to the EDR Radius Map report where detailed data on individual sites can be reviewed.

Sites listed in ***bold italics*** are in multiple databases.

Unmappable (orphan) sites are not considered in the foregoing analysis.

ADDITIONAL ENVIRONMENTAL RECORDS

Other Ascertainable Records

DOD: Consists of federally owned or administered lands, administered by the Department of Defense, that have any area equal to or greater than 640 acres of the United States, Puerto Rico, and the U.S. Virgin Islands.

A review of the DOD list, as provided by EDR, and dated 06/07/2021 has revealed that there is 1 DOD site within approximately 1 mile of the target property.

<u>Equal/Higher Elevation</u>	<u>Address</u>	<u>Direction / Distance</u>	<u>Map ID</u>	<u>Page</u>
CHOC MT AIR GNRV RNG		NE 1/4 - 1/2 (0.481 mi.)	0	9

EXECUTIVE SUMMARY

There were no unmapped sites in this report.

OVERVIEW MAP - 7022950.2S

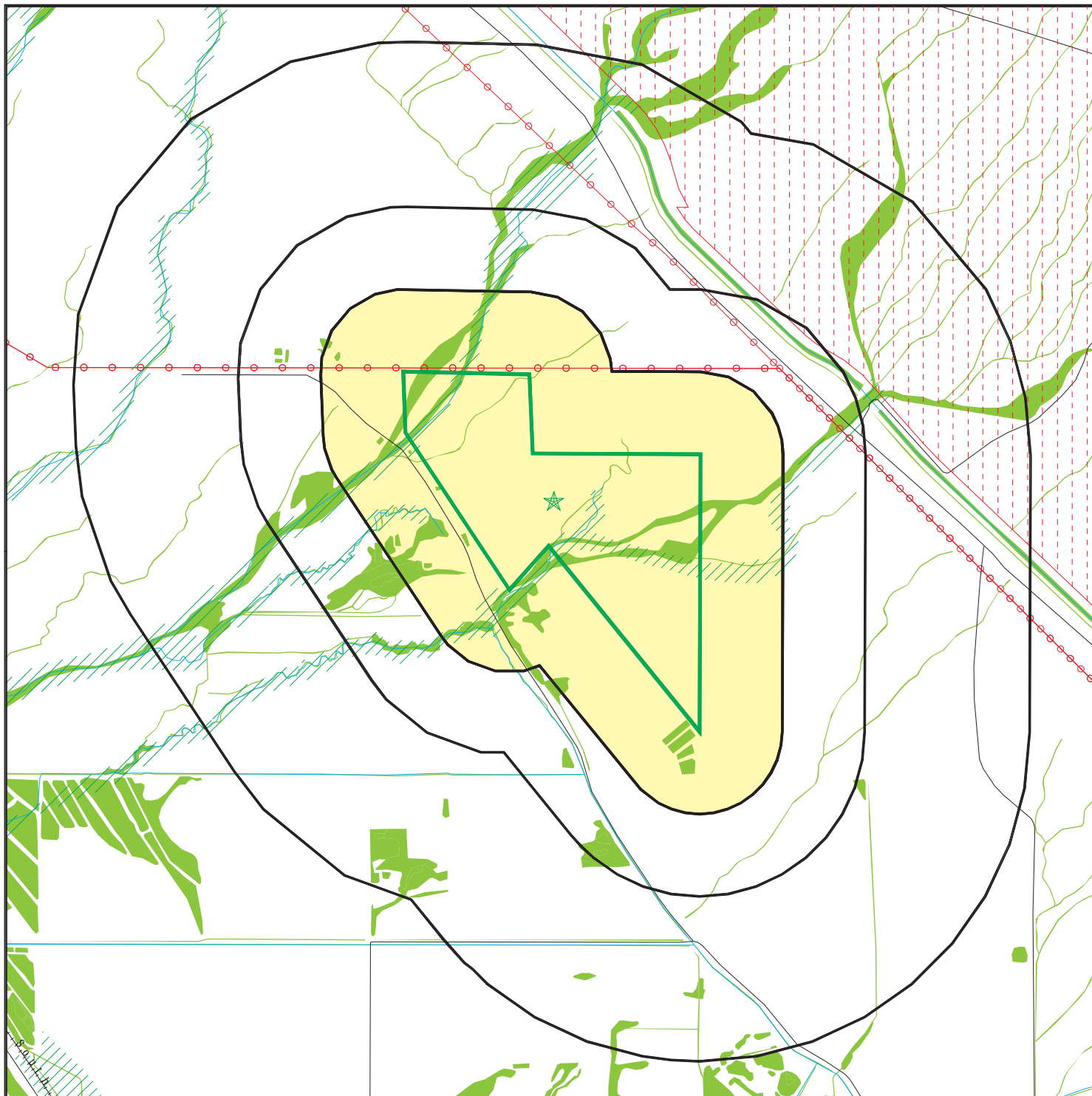

Target Property

Sites at elevations higher than or equal to the target property

Sites at elevations lower than the target property

Manufactured Gas Plants

National Priority List Sites

Dept. Defense Sites

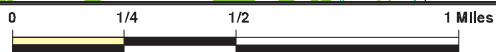

Indian Reservations BIA

Areas of Concern

Power transmission lines

Special Flood Hazard Area (1%)

0.2% Annual Chance Flood Hazard

National Wetland Inventory

State Wetlands



This report includes Interactive Map Layers to display and/or hide map information. The legend includes only those icons for the default map view.

SITE NAME: Northstar 1 Solar Project
 ADDRESS: EHL Canal and Niland Lateral 6
 Calipatria CA 92233
 LAT/LONG: 33.333838 / 115.570058

CLIENT: GS Lyon Consultants
 CONTACT: Steven Williams
 INQUIRY #: 7022950.2s
 DATE: June 17, 2022 12:54 pm

DETAIL MAP - 7022950.2S

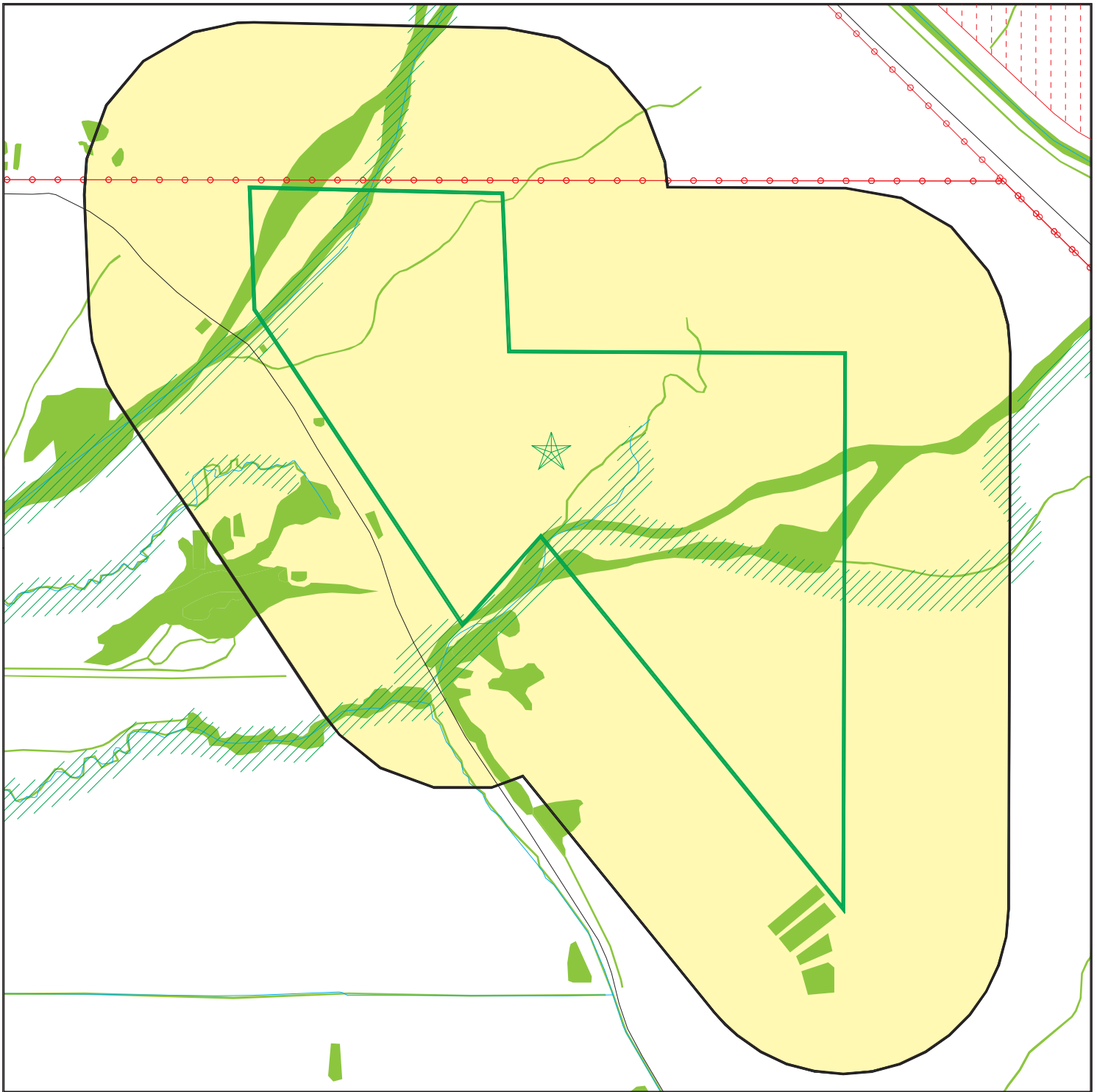

 Target Property

 Sites at elevations higher than or equal to the target property

 Sites at elevations lower than the target property

 Manufactured Gas Plants

 Sensitive Receptors

 National Priority List Sites

 Dept. Defense Sites



 Indian Reservations BIA

 Power transmission lines

 Special Flood Hazard Area (1%)

 0.2% Annual Chance Flood Hazard

 National Wetland Inventory

 State Wetlands

 Areas of Concern



This report includes Interactive Map Layers to display and/or hide map information. The legend includes only those icons for the default map view.

SITE NAME: Northstar 1 Solar Project
 ADDRESS: EHL Canal and Niland Lateral 6
 Calipatria CA 92233
 LAT/LONG: 33.333838 / 115.570058

CLIENT: GS Lyon Consultants
 CONTACT: Steven Williams
 INQUIRY #: 7022950.2s
 DATE: June 17, 2022 12:54 pm

MAP FINDINGS SUMMARY

Database	Search Distance (Miles)	Target Property	< 1/8	1/8 - 1/4	1/4 - 1/2	1/2 - 1	> 1	Total Plotted
STANDARD ENVIRONMENTAL RECORDS								
<i>Lists of Federal NPL (Superfund) sites</i>								
NPL	1.000		0	0	0	0	NR	0
Proposed NPL	1.000		0	0	0	0	NR	0
NPL LIENS	1.000		0	0	0	0	NR	0
<i>Lists of Federal Delisted NPL sites</i>								
Delisted NPL	1.000		0	0	0	0	NR	0
<i>Lists of Federal sites subject to CERCLA removals and CERCLA orders</i>								
FEDERAL FACILITY	0.500		0	0	0	NR	NR	0
SEMS	0.500		0	0	0	NR	NR	0
<i>Lists of Federal CERCLA sites with NFRAP</i>								
SEMS-ARCHIVE	0.500		0	0	0	NR	NR	0
<i>Lists of Federal RCRA facilities undergoing Corrective Action</i>								
CORRACTS	1.000		0	0	0	0	NR	0
<i>Lists of Federal RCRA TSD facilities</i>								
RCRA-TSDF	0.500		0	0	0	NR	NR	0
<i>Lists of Federal RCRA generators</i>								
RCRA-LQG	0.250		0	0	NR	NR	NR	0
RCRA-SQG	0.250		0	0	NR	NR	NR	0
RCRA-VSQG	0.250		0	0	NR	NR	NR	0
<i>Federal institutional controls / engineering controls registries</i>								
LUCIS	0.500		0	0	0	NR	NR	0
US ENG CONTROLS	0.500		0	0	0	NR	NR	0
US INST CONTROLS	0.500		0	0	0	NR	NR	0
<i>Federal ERNS list</i>								
ERNS	0.001		0	NR	NR	NR	NR	0
<i>Lists of state- and tribal (Superfund) equivalent sites</i>								
RESPONSE	1.000		0	0	0	0	NR	0
<i>Lists of state- and tribal hazardous waste facilities</i>								
ENVIROSTOR	1.000		0	0	0	0	NR	0
<i>Lists of state and tribal landfills and solid waste disposal facilities</i>								
SWF/LF	0.500		0	0	0	NR	NR	0

MAP FINDINGS SUMMARY

Database	Search Distance (Miles)	Target Property	< 1/8	1/8 - 1/4	1/4 - 1/2	1/2 - 1	> 1	Total Plotted
<i>Lists of state and tribal leaking storage tanks</i>								
LUST	0.500		0	0	0	NR	NR	0
INDIAN LUST	0.500		0	0	0	NR	NR	0
CPS-SLIC	0.500		0	0	0	NR	NR	0
<i>Lists of state and tribal registered storage tanks</i>								
FEMA UST	0.250		0	0	NR	NR	NR	0
UST	0.250		0	0	NR	NR	NR	0
AST	0.250		0	0	NR	NR	NR	0
INDIAN UST	0.250		0	0	NR	NR	NR	0
<i>Lists of state and tribal voluntary cleanup sites</i>								
VCP	0.500		0	0	0	NR	NR	0
INDIAN VCP	0.500		0	0	0	NR	NR	0
<i>Lists of state and tribal brownfield sites</i>								
BROWNFIELDS	0.500		0	0	0	NR	NR	0
<u>ADDITIONAL ENVIRONMENTAL RECORDS</u>								
<i>Local Brownfield lists</i>								
US BROWNFIELDS	0.500		0	0	0	NR	NR	0
<i>Local Lists of Landfill / Solid Waste Disposal Sites</i>								
WMUDS/SWAT	0.500		0	0	0	NR	NR	0
SWRCY	0.500		0	0	0	NR	NR	0
HAULERS	0.001		0	NR	NR	NR	NR	0
INDIAN ODI	0.500		0	0	0	NR	NR	0
DEBRIS REGION 9	0.500		0	0	0	NR	NR	0
ODI	0.500		0	0	0	NR	NR	0
IHS OPEN DUMPS	0.500		0	0	0	NR	NR	0
<i>Local Lists of Hazardous waste / Contaminated Sites</i>								
US HIST CDL	0.001		0	NR	NR	NR	NR	0
HIST Cal-Sites	1.000		0	0	0	0	NR	0
SCH	0.250		0	0	NR	NR	NR	0
CDL	0.001		0	NR	NR	NR	NR	0
Toxic Pits	1.000		0	0	0	0	NR	0
CERS HAZ WASTE	0.250		0	0	NR	NR	NR	0
US CDL	0.001		0	NR	NR	NR	NR	0
AQUEOUS FOAM	TP		NR	NR	NR	NR	NR	0
PFAS	0.500		0	0	0	NR	NR	0
<i>Local Lists of Registered Storage Tanks</i>								
SWEEPS UST	0.250		0	0	NR	NR	NR	0
HIST UST	0.250		0	0	NR	NR	NR	0
CA FID UST	0.250		0	0	NR	NR	NR	0

MAP FINDINGS SUMMARY

Database	Search Distance (Miles)	Target Property	< 1/8	1/8 - 1/4	1/4 - 1/2	1/2 - 1	> 1	Total Plotted
CERS TANKS	0.250		0	0	NR	NR	NR	0
Local Land Records								
LIENS	0.001		0	NR	NR	NR	NR	0
LIENS 2	0.001		0	NR	NR	NR	NR	0
DEED	0.500		0	0	0	NR	NR	0
Records of Emergency Release Reports								
HMIRS	0.001		0	NR	NR	NR	NR	0
CHMIRS	0.001		0	NR	NR	NR	NR	0
LDS	0.001		0	NR	NR	NR	NR	0
MCS	0.001		0	NR	NR	NR	NR	0
SPILLS 90	0.001		0	NR	NR	NR	NR	0
Other Ascertainable Records								
RCRA NonGen / NLR	0.250		0	0	NR	NR	NR	0
FUDS	1.000		0	0	0	0	NR	0
DOD	1.000		0	0	1	0	NR	1
SCRD DRYCLEANERS	0.500		0	0	0	NR	NR	0
US FIN ASSUR	0.001		0	NR	NR	NR	NR	0
EPA WATCH LIST	0.001		0	NR	NR	NR	NR	0
2020 COR ACTION	0.250		0	0	NR	NR	NR	0
TSCA	0.001		0	NR	NR	NR	NR	0
TRIS	0.001		0	NR	NR	NR	NR	0
SSTS	0.001		0	NR	NR	NR	NR	0
ROD	1.000		0	0	0	0	NR	0
RMP	0.001		0	NR	NR	NR	NR	0
RAATS	0.001		0	NR	NR	NR	NR	0
PRP	0.001		0	NR	NR	NR	NR	0
PADS	0.001		0	NR	NR	NR	NR	0
ICIS	0.001		0	NR	NR	NR	NR	0
FTTS	0.001		0	NR	NR	NR	NR	0
MLTS	0.001		0	NR	NR	NR	NR	0
COAL ASH DOE	0.001		0	NR	NR	NR	NR	0
COAL ASH EPA	0.500		0	0	0	NR	NR	0
PCB TRANSFORMER	0.001		0	NR	NR	NR	NR	0
RADINFO	0.001		0	NR	NR	NR	NR	0
HIST FTTS	0.001		0	NR	NR	NR	NR	0
DOT OPS	0.001		0	NR	NR	NR	NR	0
CONSENT	1.000		0	0	0	0	NR	0
INDIAN RESERV	1.000		0	0	0	0	NR	0
FUSRAP	1.000		0	0	0	0	NR	0
UMTRA	0.500		0	0	0	NR	NR	0
LEAD SMELTERS	0.001		0	NR	NR	NR	NR	0
US AIRS	0.001		0	NR	NR	NR	NR	0
US MINES	0.250		0	0	NR	NR	NR	0
ABANDONED MINES	0.250		0	0	NR	NR	NR	0
FINDS	0.001		0	NR	NR	NR	NR	0
UXO	1.000		0	0	0	0	NR	0
ECHO	0.001		0	NR	NR	NR	NR	0
DOCKET HWC	0.001		0	NR	NR	NR	NR	0

MAP FINDINGS SUMMARY

Database	Search Distance (Miles)	Target Property	< 1/8	1/8 - 1/4	1/4 - 1/2	1/2 - 1	> 1	Total Plotted
FUELS PROGRAM	0.250		0	0	NR	NR	NR	0
CA BOND EXP. PLAN	1.000		0	0	0	0	NR	0
Cortese	0.500		0	0	0	NR	NR	0
CUPA Listings	0.250		0	0	NR	NR	NR	0
DRYCLEANERS	0.250		0	0	NR	NR	NR	0
EMI	0.001		0	NR	NR	NR	NR	0
ENF	0.001		0	NR	NR	NR	NR	0
Financial Assurance	0.001		0	NR	NR	NR	NR	0
HAZNET	0.001		0	NR	NR	NR	NR	0
ICE	0.001		0	NR	NR	NR	NR	0
HIST CORTESE	0.500		0	0	0	NR	NR	0
HWP	1.000		0	0	0	0	NR	0
HWT	0.250		0	0	NR	NR	NR	0
MINES	0.250		0	0	NR	NR	NR	0
MWMP	0.250		0	0	NR	NR	NR	0
NPDES	0.001		0	NR	NR	NR	NR	0
PEST LIC	0.001		0	NR	NR	NR	NR	0
PROC	0.500		0	0	0	NR	NR	0
Notify 65	1.000		0	0	0	0	NR	0
UIC	0.001		0	NR	NR	NR	NR	0
UIC GEO	0.001		0	NR	NR	NR	NR	0
WASTEWATER PITS	0.500		0	0	0	NR	NR	0
WDS	0.001		0	NR	NR	NR	NR	0
WIP	0.250		0	0	NR	NR	NR	0
MILITARY PRIV SITES	0.001		0	NR	NR	NR	NR	0
PROJECT	0.001		0	NR	NR	NR	NR	0
WDR	0.001		0	NR	NR	NR	NR	0
CIWQS	0.001		0	NR	NR	NR	NR	0
CERS	0.001		0	NR	NR	NR	NR	0
NON-CASE INFO	0.001		0	NR	NR	NR	NR	0
OTHER OIL GAS	0.001		0	NR	NR	NR	NR	0
PROD WATER PONDS	0.001		0	NR	NR	NR	NR	0
SAMPLING POINT	0.001		0	NR	NR	NR	NR	0
WELL STIM PROJ	0.001		0	NR	NR	NR	NR	0
HWTS	TP		NR	NR	NR	NR	NR	0
MINES MRDS	0.001		0	NR	NR	NR	NR	0

EDR HIGH RISK HISTORICAL RECORDS

EDR Exclusive Records

EDR MGP	1.000		0	0	0	0	NR	0
EDR Hist Auto	0.125		0	NR	NR	NR	NR	0
EDR Hist Cleaner	0.125		0	NR	NR	NR	NR	0

EDR RECOVERED GOVERNMENT ARCHIVES

Exclusive Recovered Govt. Archives

RGA LF	0.001		0	NR	NR	NR	NR	0
RGA LUST	0.001		0	NR	NR	NR	NR	0

- Totals --			0	0	0	1	0	0	1
-------------	--	--	---	---	---	---	---	---	---

MAP FINDINGS SUMMARY

<u>Database</u>	<u>Search Distance (Miles)</u>	<u>Target Property</u>	<u>< 1/8</u>	<u>1/8 - 1/4</u>	<u>1/4 - 1/2</u>	<u>1/2 - 1</u>	<u>> 1</u>	<u>Total Plotted</u>
-----------------	--	----------------------------	-----------------	------------------	------------------	----------------	---------------	--------------------------

NOTES:

TP = Target Property

NR = Not Requested at this Search Distance

Sites may be listed in more than one database

MAP FINDINGS

Map ID
Direction
Distance
Elevation

Site

Database(s)

EDR ID Number
EPA ID Number

DOD
Region
NE
1/4-1/2
2542 ft.

CHOC MT AIR GNRV RNG
, CA

DOD **CUSA401327**
N/A

DOD:

Site Name:

CHOC MT AIR GNRV RNG

DOD Component:

MC Active

Joint Base:

N/A

Operating Status:

ACT (Active): Site has an on-going operational/support mission (s).

Count: 0 records.

ORPHAN SUMMARY

City	EDR ID	Site Name	Site Address	Zip	Database(s)
------	--------	-----------	--------------	-----	-------------

NO SITES FOUND

GOVERNMENT RECORDS SEARCHED / DATA CURRENCY TRACKING

To maintain currency of the following federal and state databases, EDR contacts the appropriate governmental agency on a monthly or quarterly basis, as required.

Number of Days to Update: Provides confirmation that EDR is reporting records that have been updated within 90 days from the date the government agency made the information available to the public.

STANDARD ENVIRONMENTAL RECORDS

Lists of Federal NPL (Superfund) sites

NPL: National Priority List

National Priorities List (Superfund). The NPL is a subset of CERCLIS and identifies over 1,200 sites for priority cleanup under the Superfund Program. NPL sites may encompass relatively large areas. As such, EDR provides polygon coverage for over 1,000 NPL site boundaries produced by EPA's Environmental Photographic Interpretation Center (EPIC) and regional EPA offices.

Date of Government Version: 04/27/2022	Source: EPA
Date Data Arrived at EDR: 05/05/2022	Telephone: N/A
Date Made Active in Reports: 05/31/2022	Last EDR Contact: 06/01/2022
Number of Days to Update: 26	Next Scheduled EDR Contact: 07/11/2022
	Data Release Frequency: Quarterly

NPL Site Boundaries

Sources:

EPA's Environmental Photographic Interpretation Center (EPIC)
Telephone: 202-564-7333

EPA Region 1
Telephone 617-918-1143

EPA Region 6
Telephone: 214-655-6659

EPA Region 3
Telephone 215-814-5418

EPA Region 7
Telephone: 913-551-7247

EPA Region 4
Telephone 404-562-8033

EPA Region 8
Telephone: 303-312-6774

EPA Region 5
Telephone 312-886-6686

EPA Region 9
Telephone: 415-947-4246

EPA Region 10
Telephone 206-553-8665

Proposed NPL: Proposed National Priority List Sites

A site that has been proposed for listing on the National Priorities List through the issuance of a proposed rule in the Federal Register. EPA then accepts public comments on the site, responds to the comments, and places on the NPL those sites that continue to meet the requirements for listing.

Date of Government Version: 04/27/2022	Source: EPA
Date Data Arrived at EDR: 05/05/2022	Telephone: N/A
Date Made Active in Reports: 05/31/2022	Last EDR Contact: 06/01/2022
Number of Days to Update: 26	Next Scheduled EDR Contact: 07/11/2022
	Data Release Frequency: Quarterly

NPL LIENS: Federal Superfund Liens

Federal Superfund Liens. Under the authority granted the USEPA by CERCLA of 1980, the USEPA has the authority to file liens against real property in order to recover remedial action expenditures or when the property owner received notification of potential liability. USEPA compiles a listing of filed notices of Superfund Liens.

GOVERNMENT RECORDS SEARCHED / DATA CURRENCY TRACKING

Date of Government Version: 10/15/1991
Date Data Arrived at EDR: 02/02/1994
Date Made Active in Reports: 03/30/1994
Number of Days to Update: 56

Source: EPA
Telephone: 202-564-4267
Last EDR Contact: 08/15/2011
Next Scheduled EDR Contact: 11/28/2011
Data Release Frequency: No Update Planned

Lists of Federal Delisted NPL sites

Delisted NPL: National Priority List Deletions

The National Oil and Hazardous Substances Pollution Contingency Plan (NCP) establishes the criteria that the EPA uses to delete sites from the NPL. In accordance with 40 CFR 300.425.(e), sites may be deleted from the NPL where no further response is appropriate.

Date of Government Version: 04/27/2022
Date Data Arrived at EDR: 05/05/2022
Date Made Active in Reports: 05/31/2022
Number of Days to Update: 26

Source: EPA
Telephone: N/A
Last EDR Contact: 06/01/2022
Next Scheduled EDR Contact: 07/11/2022
Data Release Frequency: Quarterly

Lists of Federal sites subject to CERCLA removals and CERCLA orders

FEDERAL FACILITY: Federal Facility Site Information listing

A listing of National Priority List (NPL) and Base Realignment and Closure (BRAC) sites found in the Comprehensive Environmental Response, Compensation and Liability Information System (CERCLIS) Database where EPA Federal Facilities Restoration and Reuse Office is involved in cleanup activities.

Date of Government Version: 05/25/2021
Date Data Arrived at EDR: 06/24/2021
Date Made Active in Reports: 09/20/2021
Number of Days to Update: 88

Source: Environmental Protection Agency
Telephone: 703-603-8704
Last EDR Contact: 04/01/2022
Next Scheduled EDR Contact: 07/11/2022
Data Release Frequency: Varies

SEMS: Superfund Enterprise Management System

SEMS (Superfund Enterprise Management System) tracks hazardous waste sites, potentially hazardous waste sites, and remedial activities performed in support of EPA's Superfund Program across the United States. The list was formerly known as CERCLIS, renamed to SEMs by the EPA in 2015. The list contains data on potentially hazardous waste sites that have been reported to the USEPA by states, municipalities, private companies and private persons, pursuant to Section 103 of the Comprehensive Environmental Response, Compensation, and Liability Act (CERCLA). This dataset also contains sites which are either proposed to or on the National Priorities List (NPL) and the sites which are in the screening and assessment phase for possible inclusion on the NPL.

Date of Government Version: 04/27/2022
Date Data Arrived at EDR: 05/05/2022
Date Made Active in Reports: 05/31/2022
Number of Days to Update: 26

Source: EPA
Telephone: 800-424-9346
Last EDR Contact: 06/01/2022
Next Scheduled EDR Contact: 07/25/2022
Data Release Frequency: Quarterly

Lists of Federal CERCLA sites with NFRAP

SEMS-ARCHIVE: Superfund Enterprise Management System Archive

GOVERNMENT RECORDS SEARCHED / DATA CURRENCY TRACKING

SEMS-ARCHIVE (Superfund Enterprise Management System Archive) tracks sites that have no further interest under the Federal Superfund Program based on available information. The list was formerly known as the CERCLIS-NFRAP, renamed to SEMS ARCHIVE by the EPA in 2015. EPA may perform a minimal level of assessment work at a site while it is archived if site conditions change and/or new information becomes available. Archived sites have been removed and archived from the inventory of SEMS sites. Archived status indicates that, to the best of EPA's knowledge, assessment at a site has been completed and that EPA has determined no further steps will be taken to list the site on the National Priorities List (NPL), unless information indicates this decision was not appropriate or other considerations require a recommendation for listing at a later time. The decision does not necessarily mean that there is no hazard associated with a given site; it only means that, based upon available information, the location is not judged to be potential NPL site.

Date of Government Version: 04/27/2022	Source: EPA
Date Data Arrived at EDR: 05/05/2022	Telephone: 800-424-9346
Date Made Active in Reports: 05/31/2022	Last EDR Contact: 06/01/2022
Number of Days to Update: 26	Next Scheduled EDR Contact: 07/25/2022
	Data Release Frequency: Quarterly

Lists of Federal RCRA facilities undergoing Corrective Action

CORRACTS: Corrective Action Report

CORRACTS identifies hazardous waste handlers with RCRA corrective action activity.

Date of Government Version: 02/28/2022	Source: EPA
Date Data Arrived at EDR: 03/02/2022	Telephone: 800-424-9346
Date Made Active in Reports: 03/17/2022	Last EDR Contact: 04/06/2022
Number of Days to Update: 15	Next Scheduled EDR Contact: 07/04/2022
	Data Release Frequency: Quarterly

Lists of Federal RCRA TSD facilities

RCRA-TSDF: RCRA - Treatment, Storage and Disposal

RCRAInfo is EPA's comprehensive information system, providing access to data supporting the Resource Conservation and Recovery Act (RCRA) of 1976 and the Hazardous and Solid Waste Amendments (HSWA) of 1984. The database includes selective information on sites which generate, transport, store, treat and/or dispose of hazardous waste as defined by the Resource Conservation and Recovery Act (RCRA). Transporters are individuals or entities that move hazardous waste from the generator offsite to a facility that can recycle, treat, store, or dispose of the waste. TSDFs treat, store, or dispose of the waste.

Date of Government Version: 02/28/2022	Source: Environmental Protection Agency
Date Data Arrived at EDR: 03/02/2022	Telephone: (415) 495-8895
Date Made Active in Reports: 03/17/2022	Last EDR Contact: 04/06/2022
Number of Days to Update: 15	Next Scheduled EDR Contact: 07/04/2022
	Data Release Frequency: Quarterly

Lists of Federal RCRA generators

RCRA-LQG: RCRA - Large Quantity Generators

RCRAInfo is EPA's comprehensive information system, providing access to data supporting the Resource Conservation and Recovery Act (RCRA) of 1976 and the Hazardous and Solid Waste Amendments (HSWA) of 1984. The database includes selective information on sites which generate, transport, store, treat and/or dispose of hazardous waste as defined by the Resource Conservation and Recovery Act (RCRA). Large quantity generators (LQGs) generate over 1,000 kilograms (kg) of hazardous waste, or over 1 kg of acutely hazardous waste per month.

Date of Government Version: 02/28/2022	Source: Environmental Protection Agency
Date Data Arrived at EDR: 03/02/2022	Telephone: (415) 495-8895
Date Made Active in Reports: 03/17/2022	Last EDR Contact: 04/06/2022
Number of Days to Update: 15	Next Scheduled EDR Contact: 07/04/2022
	Data Release Frequency: Quarterly

GOVERNMENT RECORDS SEARCHED / DATA CURRENCY TRACKING

RCRA-SQG: RCRA - Small Quantity Generators

RCRAInfo is EPA's comprehensive information system, providing access to data supporting the Resource Conservation and Recovery Act (RCRA) of 1976 and the Hazardous and Solid Waste Amendments (HSWA) of 1984. The database includes selective information on sites which generate, transport, store, treat and/or dispose of hazardous waste as defined by the Resource Conservation and Recovery Act (RCRA). Small quantity generators (SQGs) generate between 100 kg and 1,000 kg of hazardous waste per month.

Date of Government Version: 02/28/2022	Source: Environmental Protection Agency
Date Data Arrived at EDR: 03/02/2022	Telephone: (415) 495-8895
Date Made Active in Reports: 03/17/2022	Last EDR Contact: 04/06/2022
Number of Days to Update: 15	Next Scheduled EDR Contact: 07/04/2022
	Data Release Frequency: Quarterly

RCRA-VSQG: RCRA - Very Small Quantity Generators (Formerly Conditionally Exempt Small Quantity Generators)

RCRAInfo is EPA's comprehensive information system, providing access to data supporting the Resource Conservation and Recovery Act (RCRA) of 1976 and the Hazardous and Solid Waste Amendments (HSWA) of 1984. The database includes selective information on sites which generate, transport, store, treat and/or dispose of hazardous waste as defined by the Resource Conservation and Recovery Act (RCRA). Very small quantity generators (VSQGs) generate less than 100 kg of hazardous waste, or less than 1 kg of acutely hazardous waste per month.

Date of Government Version: 02/28/2022	Source: Environmental Protection Agency
Date Data Arrived at EDR: 03/02/2022	Telephone: (415) 495-8895
Date Made Active in Reports: 03/17/2022	Last EDR Contact: 04/06/2022
Number of Days to Update: 15	Next Scheduled EDR Contact: 07/04/2022
	Data Release Frequency: Quarterly

Federal institutional controls / engineering controls registries

LUCIS: Land Use Control Information System

LUCIS contains records of land use control information pertaining to the former Navy Base Realignment and Closure properties.

Date of Government Version: 02/08/2022	Source: Department of the Navy
Date Data Arrived at EDR: 02/11/2022	Telephone: 843-820-7326
Date Made Active in Reports: 05/10/2022	Last EDR Contact: 05/05/2022
Number of Days to Update: 88	Next Scheduled EDR Contact: 08/22/2022
	Data Release Frequency: Varies

US ENG CONTROLS: Engineering Controls Sites List

A listing of sites with engineering controls in place. Engineering controls include various forms of caps, building foundations, liners, and treatment methods to create pathway elimination for regulated substances to enter environmental media or effect human health.

Date of Government Version: 02/21/2022	Source: Environmental Protection Agency
Date Data Arrived at EDR: 02/23/2022	Telephone: 703-603-0695
Date Made Active in Reports: 05/24/2022	Last EDR Contact: 05/24/2022
Number of Days to Update: 90	Next Scheduled EDR Contact: 09/05/2022
	Data Release Frequency: Varies

US INST CONTROLS: Institutional Controls Sites List

A listing of sites with institutional controls in place. Institutional controls include administrative measures, such as groundwater use restrictions, construction restrictions, property use restrictions, and post remediation care requirements intended to prevent exposure to contaminants remaining on site. Deed restrictions are generally required as part of the institutional controls.

Date of Government Version: 02/21/2022	Source: Environmental Protection Agency
Date Data Arrived at EDR: 02/23/2022	Telephone: 703-603-0695
Date Made Active in Reports: 05/24/2022	Last EDR Contact: 05/04/2022
Number of Days to Update: 90	Next Scheduled EDR Contact: 09/05/2022
	Data Release Frequency: Varies

GOVERNMENT RECORDS SEARCHED / DATA CURRENCY TRACKING

Federal ERNS list

ERNS: Emergency Response Notification System

Emergency Response Notification System. ERNS records and stores information on reported releases of oil and hazardous substances.

Date of Government Version: 12/31/2021

Source: National Response Center, United States Coast Guard

Date Data Arrived at EDR: 03/01/2022

Telephone: 202-267-2180

Date Made Active in Reports: 03/10/2022

Last EDR Contact: 06/15/2022

Number of Days to Update: 9

Next Scheduled EDR Contact: 10/03/2022

Data Release Frequency: Quarterly

Lists of state- and tribal (Superfund) equivalent sites

RESPONSE: State Response Sites

Identifies confirmed release sites where DTSC is involved in remediation, either in a lead or oversight capacity. These confirmed release sites are generally high-priority and high potential risk.

Date of Government Version: 01/24/2022

Source: Department of Toxic Substances Control

Date Data Arrived at EDR: 01/25/2022

Telephone: 916-323-3400

Date Made Active in Reports: 04/13/2022

Last EDR Contact: 04/26/2022

Number of Days to Update: 78

Next Scheduled EDR Contact: 08/08/2022

Data Release Frequency: Quarterly

Lists of state- and tribal hazardous waste facilities

ENVIROSTOR: EnviroStor Database

The Department of Toxic Substances Control's (DTSC's) Site Mitigation and Brownfields Reuse Program's (SMBRP's) EnviroStor database identifies sites that have known contamination or sites for which there may be reasons to investigate further. The database includes the following site types: Federal Superfund sites (National Priorities List (NPL)); State Response, including Military Facilities and State Superfund; Voluntary Cleanup; and School sites. EnviroStor provides similar information to the information that was available in CalSites, and provides additional site information, including, but not limited to, identification of formerly-contaminated properties that have been released for reuse, properties where environmental deed restrictions have been recorded to prevent inappropriate land uses, and risk characterization information that is used to assess potential impacts to public health and the environment at contaminated sites.

Date of Government Version: 01/24/2022

Source: Department of Toxic Substances Control

Date Data Arrived at EDR: 01/25/2022

Telephone: 916-323-3400

Date Made Active in Reports: 04/13/2022

Last EDR Contact: 04/26/2022

Number of Days to Update: 78

Next Scheduled EDR Contact: 08/08/2022

Data Release Frequency: Quarterly

Lists of state and tribal landfills and solid waste disposal facilities

SWF/LF (SWIS): Solid Waste Information System

Active, Closed and Inactive Landfills. SWF/LF records typically contain an inventory of solid waste disposal facilities or landfills. These may be active or inactive facilities or open dumps that failed to meet RCRA Section 4004 criteria for solid waste landfills or disposal sites.

Date of Government Version: 02/07/2022

Source: Department of Resources Recycling and Recovery

Date Data Arrived at EDR: 02/08/2022

Telephone: 916-341-6320

Date Made Active in Reports: 05/05/2022

Last EDR Contact: 05/09/2022

Number of Days to Update: 86

Next Scheduled EDR Contact: 08/22/2022

Data Release Frequency: Quarterly

Lists of state and tribal leaking storage tanks

GOVERNMENT RECORDS SEARCHED / DATA CURRENCY TRACKING

LUST REG 6L: Leaking Underground Storage Tank Case Listing

For more current information, please refer to the State Water Resources Control Board's LUST database.

Date of Government Version: 09/09/2003	Source: California Regional Water Quality Control Board Lahontan Region (6)
Date Data Arrived at EDR: 09/10/2003	Telephone: 530-542-5572
Date Made Active in Reports: 10/07/2003	Last EDR Contact: 09/12/2011
Number of Days to Update: 27	Next Scheduled EDR Contact: 12/26/2011
	Data Release Frequency: No Update Planned

LUST REG 9: Leaking Underground Storage Tank Report

Orange, Riverside, San Diego counties. For more current information, please refer to the State Water Resources Control Board's LUST database.

Date of Government Version: 03/01/2001	Source: California Regional Water Quality Control Board San Diego Region (9)
Date Data Arrived at EDR: 04/23/2001	Telephone: 858-637-5595
Date Made Active in Reports: 05/21/2001	Last EDR Contact: 09/26/2011
Number of Days to Update: 28	Next Scheduled EDR Contact: 01/09/2012
	Data Release Frequency: No Update Planned

LUST REG 8: Leaking Underground Storage Tanks

California Regional Water Quality Control Board Santa Ana Region (8). For more current information, please refer to the State Water Resources Control Board's LUST database.

Date of Government Version: 02/14/2005	Source: California Regional Water Quality Control Board Santa Ana Region (8)
Date Data Arrived at EDR: 02/15/2005	Telephone: 909-782-4496
Date Made Active in Reports: 03/28/2005	Last EDR Contact: 08/15/2011
Number of Days to Update: 41	Next Scheduled EDR Contact: 11/28/2011
	Data Release Frequency: No Update Planned

LUST REG 7: Leaking Underground Storage Tank Case Listing

Leaking Underground Storage Tank locations. Imperial, Riverside, San Diego, Santa Barbara counties.

Date of Government Version: 02/26/2004	Source: California Regional Water Quality Control Board Colorado River Basin Region (7)
Date Data Arrived at EDR: 02/26/2004	Telephone: 760-776-8943
Date Made Active in Reports: 03/24/2004	Last EDR Contact: 08/01/2011
Number of Days to Update: 27	Next Scheduled EDR Contact: 11/14/2011
	Data Release Frequency: No Update Planned

LUST REG 5: Leaking Underground Storage Tank Database

Leaking Underground Storage Tank locations. Alameda, Alpine, Amador, Butte, Colusa, Contra Costa, Calveras, El Dorado, Fresno, Glenn, Kern, Kings, Lake, Lassen, Madera, Mariposa, Merced, Modoc, Napa, Nevada, Placer, Plumas, Sacramento, San Joaquin, Shasta, Solano, Stanislaus, Sutter, Tehama, Tulare, Tuolumne, Yolo, Yuba counties.

Date of Government Version: 07/01/2008	Source: California Regional Water Quality Control Board Central Valley Region (5)
Date Data Arrived at EDR: 07/22/2008	Telephone: 916-464-4834
Date Made Active in Reports: 07/31/2008	Last EDR Contact: 07/01/2011
Number of Days to Update: 9	Next Scheduled EDR Contact: 10/17/2011
	Data Release Frequency: No Update Planned

LUST REG 4: Underground Storage Tank Leak List

Los Angeles, Ventura counties. For more current information, please refer to the State Water Resources Control Board's LUST database.

Date of Government Version: 09/07/2004	Source: California Regional Water Quality Control Board Los Angeles Region (4)
Date Data Arrived at EDR: 09/07/2004	Telephone: 213-576-6710
Date Made Active in Reports: 10/12/2004	Last EDR Contact: 09/06/2011
Number of Days to Update: 35	Next Scheduled EDR Contact: 12/19/2011
	Data Release Frequency: No Update Planned

GOVERNMENT RECORDS SEARCHED / DATA CURRENCY TRACKING

LUST REG 3: Leaking Underground Storage Tank Database

Leaking Underground Storage Tank locations. Monterey, San Benito, San Luis Obispo, Santa Barbara, Santa Cruz counties.

Date of Government Version: 05/19/2003	Source: California Regional Water Quality Control Board Central Coast Region (3)
Date Data Arrived at EDR: 05/19/2003	Telephone: 805-542-4786
Date Made Active in Reports: 06/02/2003	Last EDR Contact: 07/18/2011
Number of Days to Update: 14	Next Scheduled EDR Contact: 10/31/2011
	Data Release Frequency: No Update Planned

LUST REG 2: Fuel Leak List

Leaking Underground Storage Tank locations. Alameda, Contra Costa, Marin, Napa, San Francisco, San Mateo, Santa Clara, Solano, Sonoma counties.

Date of Government Version: 09/30/2004	Source: California Regional Water Quality Control Board San Francisco Bay Region (2)
Date Data Arrived at EDR: 10/20/2004	Telephone: 510-622-2433
Date Made Active in Reports: 11/19/2004	Last EDR Contact: 09/19/2011
Number of Days to Update: 30	Next Scheduled EDR Contact: 01/02/2012
	Data Release Frequency: No Update Planned

LUST REG 1: Active Toxic Site Investigation

Del Norte, Humboldt, Lake, Mendocino, Modoc, Siskiyou, Sonoma, Trinity counties. For more current information, please refer to the State Water Resources Control Board's LUST database.

Date of Government Version: 02/01/2001	Source: California Regional Water Quality Control Board North Coast (1)
Date Data Arrived at EDR: 02/28/2001	Telephone: 707-570-3769
Date Made Active in Reports: 03/29/2001	Last EDR Contact: 08/01/2011
Number of Days to Update: 29	Next Scheduled EDR Contact: 11/14/2011
	Data Release Frequency: No Update Planned

LUST REG 6V: Leaking Underground Storage Tank Case Listing

Leaking Underground Storage Tank locations. Inyo, Kern, Los Angeles, Mono, San Bernardino counties.

Date of Government Version: 06/07/2005	Source: California Regional Water Quality Control Board Victorville Branch Office (6)
Date Data Arrived at EDR: 06/07/2005	Telephone: 760-241-7365
Date Made Active in Reports: 06/29/2005	Last EDR Contact: 09/12/2011
Number of Days to Update: 22	Next Scheduled EDR Contact: 12/26/2011
	Data Release Frequency: No Update Planned

LUST: Leaking Underground Fuel Tank Report (GEOTRACKER)

Leaking Underground Storage Tank (LUST) Sites included in GeoTracker. GeoTracker is the Water Boards data management system for sites that impact, or have the potential to impact, water quality in California, with emphasis on groundwater.

Date of Government Version: 05/23/2022	Source: State Water Resources Control Board
Date Data Arrived at EDR: 05/23/2022	Telephone: see region list
Date Made Active in Reports: 05/24/2022	Last EDR Contact: 05/23/2022
Number of Days to Update: 1	Next Scheduled EDR Contact: 09/19/2022
	Data Release Frequency: Quarterly

INDIAN LUST R7: Leaking Underground Storage Tanks on Indian Land

LUSTs on Indian land in Iowa, Kansas, and Nebraska

Date of Government Version: 10/12/2021	Source: EPA Region 7
Date Data Arrived at EDR: 11/15/2021	Telephone: 913-551-7003
Date Made Active in Reports: 02/08/2022	Last EDR Contact: 06/13/2022
Number of Days to Update: 85	Next Scheduled EDR Contact: 08/01/2022
	Data Release Frequency: Varies

INDIAN LUST R6: Leaking Underground Storage Tanks on Indian Land

LUSTs on Indian land in New Mexico and Oklahoma.

GOVERNMENT RECORDS SEARCHED / DATA CURRENCY TRACKING

Date of Government Version: 10/12/2021	Source: EPA Region 6
Date Data Arrived at EDR: 11/15/2021	Telephone: 214-665-6597
Date Made Active in Reports: 02/08/2022	Last EDR Contact: 06/13/2022
Number of Days to Update: 85	Next Scheduled EDR Contact: 08/01/2022
	Data Release Frequency: Varies

INDIAN LUST R1: Leaking Underground Storage Tanks on Indian Land
A listing of leaking underground storage tank locations on Indian Land.

Date of Government Version: 04/28/2021	Source: EPA Region 1
Date Data Arrived at EDR: 06/11/2021	Telephone: 617-918-1313
Date Made Active in Reports: 09/07/2021	Last EDR Contact: 06/13/2022
Number of Days to Update: 88	Next Scheduled EDR Contact: 08/01/2022
	Data Release Frequency: Varies

INDIAN LUST R8: Leaking Underground Storage Tanks on Indian Land
LUSTs on Indian land in Colorado, Montana, North Dakota, South Dakota, Utah and Wyoming.

Date of Government Version: 10/12/2021	Source: EPA Region 8
Date Data Arrived at EDR: 11/15/2021	Telephone: 303-312-6271
Date Made Active in Reports: 02/08/2022	Last EDR Contact: 06/13/2022
Number of Days to Update: 85	Next Scheduled EDR Contact: 08/01/2022
	Data Release Frequency: Varies

INDIAN LUST R9: Leaking Underground Storage Tanks on Indian Land
LUSTs on Indian land in Arizona, California, New Mexico and Nevada

Date of Government Version: 10/12/2021	Source: Environmental Protection Agency
Date Data Arrived at EDR: 11/15/2021	Telephone: 415-972-3372
Date Made Active in Reports: 02/08/2022	Last EDR Contact: 06/13/2022
Number of Days to Update: 85	Next Scheduled EDR Contact: 08/01/2022
	Data Release Frequency: Varies

INDIAN LUST R10: Leaking Underground Storage Tanks on Indian Land
LUSTs on Indian land in Alaska, Idaho, Oregon and Washington.

Date of Government Version: 10/12/2021	Source: EPA Region 10
Date Data Arrived at EDR: 11/15/2021	Telephone: 206-553-2857
Date Made Active in Reports: 02/08/2022	Last EDR Contact: 06/13/2022
Number of Days to Update: 85	Next Scheduled EDR Contact: 08/01/2022
	Data Release Frequency: Varies

INDIAN LUST R4: Leaking Underground Storage Tanks on Indian Land
LUSTs on Indian land in Florida, Mississippi and North Carolina.

Date of Government Version: 05/28/2021	Source: EPA Region 4
Date Data Arrived at EDR: 06/22/2021	Telephone: 404-562-8677
Date Made Active in Reports: 09/20/2021	Last EDR Contact: 06/13/2022
Number of Days to Update: 90	Next Scheduled EDR Contact: 08/01/2022
	Data Release Frequency: Varies

INDIAN LUST R5: Leaking Underground Storage Tanks on Indian Land
Leaking underground storage tanks located on Indian Land in Michigan, Minnesota and Wisconsin.

Date of Government Version: 10/12/2021	Source: EPA, Region 5
Date Data Arrived at EDR: 11/15/2021	Telephone: 312-886-7439
Date Made Active in Reports: 02/08/2022	Last EDR Contact: 06/13/2022
Number of Days to Update: 85	Next Scheduled EDR Contact: 08/01/2022
	Data Release Frequency: Varies

GOVERNMENT RECORDS SEARCHED / DATA CURRENCY TRACKING

CPS-SLIC: Statewide SLIC Cases (GEOTRACKER)

Cleanup Program Sites (CPS; also known as Site Cleanups [SC] and formerly known as Spills, Leaks, Investigations, and Cleanups [SLIC] sites) included in GeoTracker. GeoTracker is the Water Boards data management system for sites that impact, or have the potential to impact, water quality in California, with emphasis on groundwater.

Date of Government Version: 05/23/2022	Source: State Water Resources Control Board
Date Data Arrived at EDR: 05/23/2022	Telephone: 866-480-1028
Date Made Active in Reports: 05/24/2022	Last EDR Contact: 05/23/2022
Number of Days to Update: 1	Next Scheduled EDR Contact: 09/19/2022
	Data Release Frequency: Varies

SLIC REG 1: Active Toxic Site Investigations

The SLIC (Spills, Leaks, Investigations and Cleanup) program is designed to protect and restore water quality from spills, leaks, and similar discharges.

Date of Government Version: 04/03/2003	Source: California Regional Water Quality Control Board, North Coast Region (1)
Date Data Arrived at EDR: 04/07/2003	Telephone: 707-576-2220
Date Made Active in Reports: 04/25/2003	Last EDR Contact: 08/01/2011
Number of Days to Update: 18	Next Scheduled EDR Contact: 11/14/2011
	Data Release Frequency: No Update Planned

SLIC REG 2: Spills, Leaks, Investigation & Cleanup Cost Recovery Listing

The SLIC (Spills, Leaks, Investigations and Cleanup) program is designed to protect and restore water quality from spills, leaks, and similar discharges.

Date of Government Version: 09/30/2004	Source: Regional Water Quality Control Board San Francisco Bay Region (2)
Date Data Arrived at EDR: 10/20/2004	Telephone: 510-286-0457
Date Made Active in Reports: 11/19/2004	Last EDR Contact: 09/19/2011
Number of Days to Update: 30	Next Scheduled EDR Contact: 01/02/2012
	Data Release Frequency: No Update Planned

SLIC REG 3: Spills, Leaks, Investigation & Cleanup Cost Recovery Listing

The SLIC (Spills, Leaks, Investigations and Cleanup) program is designed to protect and restore water quality from spills, leaks, and similar discharges.

Date of Government Version: 05/18/2006	Source: California Regional Water Quality Control Board Central Coast Region (3)
Date Data Arrived at EDR: 05/18/2006	Telephone: 805-549-3147
Date Made Active in Reports: 06/15/2006	Last EDR Contact: 07/18/2011
Number of Days to Update: 28	Next Scheduled EDR Contact: 10/31/2011
	Data Release Frequency: No Update Planned

SLIC REG 4: Spills, Leaks, Investigation & Cleanup Cost Recovery Listing

The SLIC (Spills, Leaks, Investigations and Cleanup) program is designed to protect and restore water quality from spills, leaks, and similar discharges.

Date of Government Version: 11/17/2004	Source: Region Water Quality Control Board Los Angeles Region (4)
Date Data Arrived at EDR: 11/18/2004	Telephone: 213-576-6600
Date Made Active in Reports: 01/04/2005	Last EDR Contact: 07/01/2011
Number of Days to Update: 47	Next Scheduled EDR Contact: 10/17/2011
	Data Release Frequency: No Update Planned

SLIC REG 5: Spills, Leaks, Investigation & Cleanup Cost Recovery Listing

The SLIC (Spills, Leaks, Investigations and Cleanup) program is designed to protect and restore water quality from spills, leaks, and similar discharges.

Date of Government Version: 04/01/2005	Source: Regional Water Quality Control Board Central Valley Region (5)
Date Data Arrived at EDR: 04/05/2005	Telephone: 916-464-3291
Date Made Active in Reports: 04/21/2005	Last EDR Contact: 09/12/2011
Number of Days to Update: 16	Next Scheduled EDR Contact: 12/26/2011
	Data Release Frequency: No Update Planned

GOVERNMENT RECORDS SEARCHED / DATA CURRENCY TRACKING

SLIC REG 6V: Spills, Leaks, Investigation & Cleanup Cost Recovery Listing

The SLIC (Spills, Leaks, Investigations and Cleanup) program is designed to protect and restore water quality from spills, leaks, and similar discharges.

Date of Government Version: 05/24/2005
Date Data Arrived at EDR: 05/25/2005
Date Made Active in Reports: 06/16/2005
Number of Days to Update: 22

Source: Regional Water Quality Control Board, Victorville Branch
Telephone: 619-241-6583
Last EDR Contact: 08/15/2011
Next Scheduled EDR Contact: 11/28/2011
Data Release Frequency: No Update Planned

SLIC REG 6L: SLIC Sites

The SLIC (Spills, Leaks, Investigations and Cleanup) program is designed to protect and restore water quality from spills, leaks, and similar discharges.

Date of Government Version: 09/07/2004
Date Data Arrived at EDR: 09/07/2004
Date Made Active in Reports: 10/12/2004
Number of Days to Update: 35

Source: California Regional Water Quality Control Board, Lahontan Region
Telephone: 530-542-5574
Last EDR Contact: 08/15/2011
Next Scheduled EDR Contact: 11/28/2011
Data Release Frequency: No Update Planned

SLIC REG 7: SLIC List

The SLIC (Spills, Leaks, Investigations and Cleanup) program is designed to protect and restore water quality from spills, leaks, and similar discharges.

Date of Government Version: 11/24/2004
Date Data Arrived at EDR: 11/29/2004
Date Made Active in Reports: 01/04/2005
Number of Days to Update: 36

Source: California Regional Quality Control Board, Colorado River Basin Region
Telephone: 760-346-7491
Last EDR Contact: 08/01/2011
Next Scheduled EDR Contact: 11/14/2011
Data Release Frequency: No Update Planned

SLIC REG 8: Spills, Leaks, Investigation & Cleanup Cost Recovery Listing

The SLIC (Spills, Leaks, Investigations and Cleanup) program is designed to protect and restore water quality from spills, leaks, and similar discharges.

Date of Government Version: 04/03/2008
Date Data Arrived at EDR: 04/03/2008
Date Made Active in Reports: 04/14/2008
Number of Days to Update: 11

Source: California Region Water Quality Control Board Santa Ana Region (8)
Telephone: 951-782-3298
Last EDR Contact: 09/12/2011
Next Scheduled EDR Contact: 12/26/2011
Data Release Frequency: No Update Planned

SLIC REG 9: Spills, Leaks, Investigation & Cleanup Cost Recovery Listing

The SLIC (Spills, Leaks, Investigations and Cleanup) program is designed to protect and restore water quality from spills, leaks, and similar discharges.

Date of Government Version: 09/10/2007
Date Data Arrived at EDR: 09/11/2007
Date Made Active in Reports: 09/28/2007
Number of Days to Update: 17

Source: California Regional Water Quality Control Board San Diego Region (9)
Telephone: 858-467-2980
Last EDR Contact: 08/08/2011
Next Scheduled EDR Contact: 11/21/2011
Data Release Frequency: No Update Planned

Lists of state and tribal registered storage tanks

FEMA UST: Underground Storage Tank Listing

A listing of all FEMA owned underground storage tanks.

Date of Government Version: 10/14/2021
Date Data Arrived at EDR: 11/05/2021
Date Made Active in Reports: 02/01/2022
Number of Days to Update: 88

Source: FEMA
Telephone: 202-646-5797
Last EDR Contact: 04/04/2022
Next Scheduled EDR Contact: 07/18/2022
Data Release Frequency: Varies

GOVERNMENT RECORDS SEARCHED / DATA CURRENCY TRACKING

UST: Active UST Facilities

Active UST facilities gathered from the local regulatory agencies

Date of Government Version: 03/07/2022	Source: SWRCB
Date Data Arrived at EDR: 03/08/2022	Telephone: 916-341-5851
Date Made Active in Reports: 06/02/2022	Last EDR Contact: 06/07/2022
Number of Days to Update: 86	Next Scheduled EDR Contact: 09/19/2022
	Data Release Frequency: Semi-Annually

MILITARY UST SITES: Military UST Sites (GEOTRACKER)

Military ust sites

Date of Government Version: 05/23/2022	Source: State Water Resources Control Board
Date Data Arrived at EDR: 05/23/2022	Telephone: 866-480-1028
Date Made Active in Reports: 06/02/2022	Last EDR Contact: 05/23/2022
Number of Days to Update: 10	Next Scheduled EDR Contact: 09/19/2022
	Data Release Frequency: Varies

UST CLOSURE: Proposed Closure of Underground Storage Tank (UST) Cases

UST cases that are being considered for closure by either the State Water Resources Control Board or the Executive Director have been posted for a 60-day public comment period. UST Case Closures being proposed for consideration by the State Water Resources Control Board. These are primarily UST cases that meet closure criteria under the decisional framework in State Water Board Resolution No. 92-49 and other Board orders. UST Case Closures proposed for consideration by the Executive Director pursuant to State Water Board Resolution No. 2012-0061. These are cases that meet the criteria of the Low-Threat UST Case Closure Policy. UST Case Closure Review Denials and Approved Orders.

Date of Government Version: 03/07/2022	Source: State Water Resources Control Board
Date Data Arrived at EDR: 03/08/2022	Telephone: 916-327-7844
Date Made Active in Reports: 06/03/2022	Last EDR Contact: 06/09/2022
Number of Days to Update: 87	Next Scheduled EDR Contact: 09/19/2022
	Data Release Frequency: Varies

AST: Aboveground Petroleum Storage Tank Facilities

A listing of aboveground storage tank petroleum storage tank locations.

Date of Government Version: 07/06/2016	Source: California Environmental Protection Agency
Date Data Arrived at EDR: 07/12/2016	Telephone: 916-327-5092
Date Made Active in Reports: 09/19/2016	Last EDR Contact: 06/09/2022
Number of Days to Update: 69	Next Scheduled EDR Contact: 09/26/2022
	Data Release Frequency: Varies

INDIAN UST R1: Underground Storage Tanks on Indian Land

The Indian Underground Storage Tank (UST) database provides information about underground storage tanks on Indian land in EPA Region 1 (Connecticut, Maine, Massachusetts, New Hampshire, Rhode Island, Vermont and ten Tribal Nations).

Date of Government Version: 10/14/2021	Source: EPA, Region 1
Date Data Arrived at EDR: 11/15/2021	Telephone: 617-918-1313
Date Made Active in Reports: 02/08/2022	Last EDR Contact: 06/13/2022
Number of Days to Update: 85	Next Scheduled EDR Contact: 08/01/2022
	Data Release Frequency: Varies

INDIAN UST R5: Underground Storage Tanks on Indian Land

The Indian Underground Storage Tank (UST) database provides information about underground storage tanks on Indian land in EPA Region 5 (Michigan, Minnesota and Wisconsin and Tribal Nations).

Date of Government Version: 04/06/2021	Source: EPA Region 5
Date Data Arrived at EDR: 06/11/2021	Telephone: 312-886-6136
Date Made Active in Reports: 09/07/2021	Last EDR Contact: 06/13/2022
Number of Days to Update: 88	Next Scheduled EDR Contact: 08/01/2022
	Data Release Frequency: Varies

GOVERNMENT RECORDS SEARCHED / DATA CURRENCY TRACKING

INDIAN UST R6: Underground Storage Tanks on Indian Land

The Indian Underground Storage Tank (UST) database provides information about underground storage tanks on Indian land in EPA Region 6 (Louisiana, Arkansas, Oklahoma, New Mexico, Texas and 65 Tribes).

Date of Government Version: 10/12/2021	Source: EPA Region 6
Date Data Arrived at EDR: 11/15/2021	Telephone: 214-665-7591
Date Made Active in Reports: 02/08/2022	Last EDR Contact: 06/13/2022
Number of Days to Update: 85	Next Scheduled EDR Contact: 08/01/2022
	Data Release Frequency: Varies

INDIAN UST R4: Underground Storage Tanks on Indian Land

The Indian Underground Storage Tank (UST) database provides information about underground storage tanks on Indian land in EPA Region 4 (Alabama, Florida, Georgia, Kentucky, Mississippi, North Carolina, South Carolina, Tennessee and Tribal Nations)

Date of Government Version: 05/28/2021	Source: EPA Region 4
Date Data Arrived at EDR: 06/22/2021	Telephone: 404-562-9424
Date Made Active in Reports: 09/20/2021	Last EDR Contact: 06/13/2022
Number of Days to Update: 90	Next Scheduled EDR Contact: 08/01/2022
	Data Release Frequency: Varies

INDIAN UST R7: Underground Storage Tanks on Indian Land

The Indian Underground Storage Tank (UST) database provides information about underground storage tanks on Indian land in EPA Region 7 (Iowa, Kansas, Missouri, Nebraska, and 9 Tribal Nations).

Date of Government Version: 10/12/2021	Source: EPA Region 7
Date Data Arrived at EDR: 11/15/2021	Telephone: 913-551-7003
Date Made Active in Reports: 02/08/2022	Last EDR Contact: 06/13/2022
Number of Days to Update: 85	Next Scheduled EDR Contact: 08/01/2022
	Data Release Frequency: Varies

INDIAN UST R8: Underground Storage Tanks on Indian Land

The Indian Underground Storage Tank (UST) database provides information about underground storage tanks on Indian land in EPA Region 8 (Colorado, Montana, North Dakota, South Dakota, Utah, Wyoming and 27 Tribal Nations).

Date of Government Version: 10/12/2021	Source: EPA Region 8
Date Data Arrived at EDR: 11/15/2021	Telephone: 303-312-6137
Date Made Active in Reports: 02/08/2022	Last EDR Contact: 06/13/2022
Number of Days to Update: 85	Next Scheduled EDR Contact: 08/01/2022
	Data Release Frequency: Varies

INDIAN UST R9: Underground Storage Tanks on Indian Land

The Indian Underground Storage Tank (UST) database provides information about underground storage tanks on Indian land in EPA Region 9 (Arizona, California, Hawaii, Nevada, the Pacific Islands, and Tribal Nations).

Date of Government Version: 10/12/2021	Source: EPA Region 9
Date Data Arrived at EDR: 11/15/2021	Telephone: 415-972-3368
Date Made Active in Reports: 02/08/2022	Last EDR Contact: 06/13/2022
Number of Days to Update: 85	Next Scheduled EDR Contact: 08/01/2022
	Data Release Frequency: Varies

INDIAN UST R10: Underground Storage Tanks on Indian Land

The Indian Underground Storage Tank (UST) database provides information about underground storage tanks on Indian land in EPA Region 10 (Alaska, Idaho, Oregon, Washington, and Tribal Nations).

Date of Government Version: 10/12/2021	Source: EPA Region 10
Date Data Arrived at EDR: 11/15/2021	Telephone: 206-553-2857
Date Made Active in Reports: 02/08/2022	Last EDR Contact: 06/13/2022
Number of Days to Update: 85	Next Scheduled EDR Contact: 08/01/2022
	Data Release Frequency: Varies

GOVERNMENT RECORDS SEARCHED / DATA CURRENCY TRACKING

Lists of state and tribal voluntary cleanup sites

INDIAN VCP R1: Voluntary Cleanup Priority Listing

A listing of voluntary cleanup priority sites located on Indian Land located in Region 1.

Date of Government Version: 07/27/2015	Source: EPA, Region 1
Date Data Arrived at EDR: 09/29/2015	Telephone: 617-918-1102
Date Made Active in Reports: 02/18/2016	Last EDR Contact: 06/15/2022
Number of Days to Update: 142	Next Scheduled EDR Contact: 10/03/2022
	Data Release Frequency: Varies

VCP: Voluntary Cleanup Program Properties

Contains low threat level properties with either confirmed or unconfirmed releases and the project proponents have request that DTSC oversee investigation and/or cleanup activities and have agreed to provide coverage for DTSC's costs.

Date of Government Version: 01/24/2022	Source: Department of Toxic Substances Control
Date Data Arrived at EDR: 01/25/2022	Telephone: 916-323-3400
Date Made Active in Reports: 04/13/2022	Last EDR Contact: 04/26/2022
Number of Days to Update: 78	Next Scheduled EDR Contact: 08/08/2022
	Data Release Frequency: Quarterly

INDIAN VCP R7: Voluntary Cleanup Priority Listing

A listing of voluntary cleanup priority sites located on Indian Land located in Region 7.

Date of Government Version: 03/20/2008	Source: EPA, Region 7
Date Data Arrived at EDR: 04/22/2008	Telephone: 913-551-7365
Date Made Active in Reports: 05/19/2008	Last EDR Contact: 07/08/2021
Number of Days to Update: 27	Next Scheduled EDR Contact: 07/20/2009
	Data Release Frequency: Varies

Lists of state and tribal brownfield sites

BROWNFIELDS: Considered Brownfields Sites Listing

A listing of sites the SWRCB considers to be Brownfields since these are sites have come to them through the MOA Process.

Date of Government Version: 03/21/2022	Source: State Water Resources Control Board
Date Data Arrived at EDR: 03/21/2022	Telephone: 916-323-7905
Date Made Active in Reports: 06/14/2022	Last EDR Contact: 03/21/2022
Number of Days to Update: 85	Next Scheduled EDR Contact: 07/04/2022
	Data Release Frequency: Quarterly

ADDITIONAL ENVIRONMENTAL RECORDS

Local Brownfield lists

US BROWNFIELDS: A Listing of Brownfields Sites

Brownfields are real property, the expansion, redevelopment, or reuse of which may be complicated by the presence or potential presence of a hazardous substance, pollutant, or contaminant. Cleaning up and reinvesting in these properties takes development pressures off of undeveloped, open land, and both improves and protects the environment. Assessment, Cleanup and Redevelopment Exchange System (ACRES) stores information reported by EPA Brownfields grant recipients on brownfields properties assessed or cleaned up with grant funding as well as information on Targeted Brownfields Assessments performed by EPA Regions. A listing of ACRES Brownfield sites is obtained from Cleanups in My Community. Cleanups in My Community provides information on Brownfields properties for which information is reported back to EPA, as well as areas served by Brownfields grant programs.

Date of Government Version: 02/23/2022	Source: Environmental Protection Agency
Date Data Arrived at EDR: 03/10/2022	Telephone: 202-566-2777
Date Made Active in Reports: 03/10/2022	Last EDR Contact: 06/13/2022
Number of Days to Update: 0	Next Scheduled EDR Contact: 09/26/2022
	Data Release Frequency: Semi-Annually

GOVERNMENT RECORDS SEARCHED / DATA CURRENCY TRACKING

Local Lists of Landfill / Solid Waste Disposal Sites

WMUDS/SWAT: Waste Management Unit Database

Waste Management Unit Database System. WMUDS is used by the State Water Resources Control Board staff and the Regional Water Quality Control Boards for program tracking and inventory of waste management units. WMUDS is composed of the following databases: Facility Information, Scheduled Inspections Information, Waste Management Unit Information, SWAT Program Information, SWAT Report Summary Information, SWAT Report Summary Data, Chapter 15 (formerly Subchapter 15) Information, Chapter 15 Monitoring Parameters, TPCA Program Information, RCRA Program Information, Closure Information, and Interested Parties Information.

Date of Government Version: 04/01/2000	Source: State Water Resources Control Board
Date Data Arrived at EDR: 04/10/2000	Telephone: 916-227-4448
Date Made Active in Reports: 05/10/2000	Last EDR Contact: 04/21/2022
Number of Days to Update: 30	Next Scheduled EDR Contact: 08/08/2022
	Data Release Frequency: No Update Planned

SWRCY: Recycler Database

A listing of recycling facilities in California.

Date of Government Version: 03/07/2022	Source: Department of Conservation
Date Data Arrived at EDR: 03/08/2022	Telephone: 916-323-3836
Date Made Active in Reports: 06/02/2022	Last EDR Contact: 06/07/2022
Number of Days to Update: 86	Next Scheduled EDR Contact: 09/19/2022
	Data Release Frequency: Quarterly

HAULERS: Registered Waste Tire Haulers Listing

A listing of registered waste tire haulers.

Date of Government Version: 02/15/2022	Source: Integrated Waste Management Board
Date Data Arrived at EDR: 02/24/2022	Telephone: 916-341-6422
Date Made Active in Reports: 05/25/2022	Last EDR Contact: 05/19/2022
Number of Days to Update: 90	Next Scheduled EDR Contact: 08/22/2022
	Data Release Frequency: Varies

INDIAN ODI: Report on the Status of Open Dumps on Indian Lands

Location of open dumps on Indian land.

Date of Government Version: 12/31/1998	Source: Environmental Protection Agency
Date Data Arrived at EDR: 12/03/2007	Telephone: 703-308-8245
Date Made Active in Reports: 01/24/2008	Last EDR Contact: 04/21/2022
Number of Days to Update: 52	Next Scheduled EDR Contact: 08/08/2022
	Data Release Frequency: Varies

ODI: Open Dump Inventory

An open dump is defined as a disposal facility that does not comply with one or more of the Part 257 or Part 258 Subtitle D Criteria.

Date of Government Version: 06/30/1985	Source: Environmental Protection Agency
Date Data Arrived at EDR: 08/09/2004	Telephone: 800-424-9346
Date Made Active in Reports: 09/17/2004	Last EDR Contact: 06/09/2004
Number of Days to Update: 39	Next Scheduled EDR Contact: N/A
	Data Release Frequency: No Update Planned

DEBRIS REGION 9: Torres Martinez Reservation Illegal Dump Site Locations

A listing of illegal dump sites location on the Torres Martinez Indian Reservation located in eastern Riverside County and northern Imperial County, California.

Date of Government Version: 01/12/2009	Source: EPA, Region 9
Date Data Arrived at EDR: 05/07/2009	Telephone: 415-947-4219
Date Made Active in Reports: 09/21/2009	Last EDR Contact: 04/14/2022
Number of Days to Update: 137	Next Scheduled EDR Contact: 08/01/2022
	Data Release Frequency: No Update Planned

GOVERNMENT RECORDS SEARCHED / DATA CURRENCY TRACKING

IHS OPEN DUMPS: Open Dumps on Indian Land

A listing of all open dumps located on Indian Land in the United States.

Date of Government Version: 04/01/2014	Source: Department of Health & Human Services, Indian Health Service
Date Data Arrived at EDR: 08/06/2014	Telephone: 301-443-1452
Date Made Active in Reports: 01/29/2015	Last EDR Contact: 04/28/2022
Number of Days to Update: 176	Next Scheduled EDR Contact: 08/08/2022
	Data Release Frequency: Varies

Local Lists of Hazardous waste / Contaminated Sites

US HIST CDL: National Clandestine Laboratory Register

A listing of clandestine drug lab locations that have been removed from the DEAs National Clandestine Laboratory Register.

Date of Government Version: 02/22/2022	Source: Drug Enforcement Administration
Date Data Arrived at EDR: 02/23/2022	Telephone: 202-307-1000
Date Made Active in Reports: 05/10/2022	Last EDR Contact: 05/24/2022
Number of Days to Update: 76	Next Scheduled EDR Contact: 09/05/2022
	Data Release Frequency: No Update Planned

HIST CAL-SITES: Calsites Database

The Calsites database contains potential or confirmed hazardous substance release properties. In 1996, California EPA reevaluated and significantly reduced the number of sites in the Calsites database. No longer updated by the state agency. It has been replaced by ENVIROSTOR.

Date of Government Version: 08/08/2005	Source: Department of Toxic Substance Control
Date Data Arrived at EDR: 08/03/2006	Telephone: 916-323-3400
Date Made Active in Reports: 08/24/2006	Last EDR Contact: 02/23/2009
Number of Days to Update: 21	Next Scheduled EDR Contact: 05/25/2009
	Data Release Frequency: No Update Planned

SCH: School Property Evaluation Program

This category contains proposed and existing school sites that are being evaluated by DTSC for possible hazardous materials contamination. In some cases, these properties may be listed in the CalSites category depending on the level of threat to public health and safety or the environment they pose.

Date of Government Version: 01/24/2022	Source: Department of Toxic Substances Control
Date Data Arrived at EDR: 01/25/2022	Telephone: 916-323-3400
Date Made Active in Reports: 04/13/2022	Last EDR Contact: 04/26/2022
Number of Days to Update: 78	Next Scheduled EDR Contact: 08/08/2022
	Data Release Frequency: Quarterly

CDL: Clandestine Drug Labs

A listing of drug lab locations. Listing of a location in this database does not indicate that any illegal drug lab materials were or were not present there, and does not constitute a determination that the location either requires or does not require additional cleanup work.

Date of Government Version: 12/31/2019	Source: Department of Toxic Substances Control
Date Data Arrived at EDR: 01/20/2021	Telephone: 916-255-6504
Date Made Active in Reports: 04/08/2021	Last EDR Contact: 05/12/2022
Number of Days to Update: 78	Next Scheduled EDR Contact: 07/18/2022
	Data Release Frequency: Varies

TOXIC PITS: Toxic Pits Cleanup Act Sites

Toxic PITS Cleanup Act Sites. TOXIC PITS identifies sites suspected of containing hazardous substances where cleanup has not yet been completed.

Date of Government Version: 07/01/1995	Source: State Water Resources Control Board
Date Data Arrived at EDR: 08/30/1995	Telephone: 916-227-4364
Date Made Active in Reports: 09/26/1995	Last EDR Contact: 01/26/2009
Number of Days to Update: 27	Next Scheduled EDR Contact: 04/27/2009
	Data Release Frequency: No Update Planned

GOVERNMENT RECORDS SEARCHED / DATA CURRENCY TRACKING

CERS HAZ WASTE: CERS HAZ WASTE

List of sites in the California Environmental Protection Agency (CalEPA) Regulated Site Portal which fall under the Hazardous Chemical Management, Hazardous Waste Onsite Treatment, Household Hazardous Waste Collection, Hazardous Waste Generator, and RCRA LQ HW Generator programs.

Date of Government Version: 01/18/2022	Source: CalEPA
Date Data Arrived at EDR: 01/19/2022	Telephone: 916-323-2514
Date Made Active in Reports: 04/11/2022	Last EDR Contact: 04/19/2022
Number of Days to Update: 82	Next Scheduled EDR Contact: 08/01/2022
	Data Release Frequency: Quarterly

US CDL: Clandestine Drug Labs

A listing of clandestine drug lab locations. The U.S. Department of Justice ("the Department") provides this web site as a public service. It contains addresses of some locations where law enforcement agencies reported they found chemicals or other items that indicated the presence of either clandestine drug laboratories or dumpsites. In most cases, the source of the entries is not the Department, and the Department has not verified the entry and does not guarantee its accuracy. Members of the public must verify the accuracy of all entries by, for example, contacting local law enforcement and local health departments.

Date of Government Version: 02/22/2022	Source: Drug Enforcement Administration
Date Data Arrived at EDR: 02/23/2022	Telephone: 202-307-1000
Date Made Active in Reports: 05/10/2022	Last EDR Contact: 05/24/2022
Number of Days to Update: 76	Next Scheduled EDR Contact: 09/05/2022
	Data Release Frequency: Quarterly

AQUEOUS FOAM: Former Fire Training Facility Assessments Listing

Airports shown on this list are those believed to use Aqueous Film Forming Foam (AFFF), and certified by the Federal Aviation Administration (FAA) under Title 14, Code of Federal Regulations (CFR), Part 139 (14 CFR Part 139). This list was created by SWRCB using information available from the FAA. Location points shown are from the latitude and longitude listed on the FAA airport master record.

Date of Government Version: 02/20/2020	Source: State Water Resources Control Board
Date Data Arrived at EDR: 12/10/2021	Telephone: 916-341-5455
Date Made Active in Reports: 02/25/2022	Last EDR Contact: 06/10/2022
Number of Days to Update: 77	Next Scheduled EDR Contact: 09/19/2022
	Data Release Frequency: Varies

PFAS: PFAS Contamination Site Location Listing

A listing of PFAS contaminated sites included in the GeoTracker database.

Date of Government Version: 03/07/2022	Source: State Water Resources Control Board
Date Data Arrived at EDR: 03/08/2022	Telephone: 866-480-1028
Date Made Active in Reports: 06/02/2022	Last EDR Contact: 06/07/2022
Number of Days to Update: 86	Next Scheduled EDR Contact: 09/19/2022
	Data Release Frequency: Varies

Local Lists of Registered Storage Tanks

SWEEPS UST: SWEEPS UST Listing

Statewide Environmental Evaluation and Planning System. This underground storage tank listing was updated and maintained by a company contacted by the SWRCB in the early 1990's. The listing is no longer updated or maintained. The local agency is the contact for more information on a site on the SWEEPS list.

Date of Government Version: 06/01/1994	Source: State Water Resources Control Board
Date Data Arrived at EDR: 07/07/2005	Telephone: N/A
Date Made Active in Reports: 08/11/2005	Last EDR Contact: 06/03/2005
Number of Days to Update: 35	Next Scheduled EDR Contact: N/A
	Data Release Frequency: No Update Planned

GOVERNMENT RECORDS SEARCHED / DATA CURRENCY TRACKING

HIST UST: Hazardous Substance Storage Container Database

The Hazardous Substance Storage Container Database is a historical listing of UST sites. Refer to local/county source for current data.

Date of Government Version: 10/15/1990	Source: State Water Resources Control Board
Date Data Arrived at EDR: 01/25/1991	Telephone: 916-341-5851
Date Made Active in Reports: 02/12/1991	Last EDR Contact: 07/26/2001
Number of Days to Update: 18	Next Scheduled EDR Contact: N/A
	Data Release Frequency: No Update Planned

SAN FRANCISCO AST: Aboveground Storage Tank Site Listing

Aboveground storage tank sites

Date of Government Version: 02/03/2022	Source: San Francisco County Department of Public Health
Date Data Arrived at EDR: 02/04/2022	Telephone: 415-252-3896
Date Made Active in Reports: 05/02/2022	Last EDR Contact: 04/28/2022
Number of Days to Update: 87	Next Scheduled EDR Contact: 08/15/2022
	Data Release Frequency: Varies

CA FID UST: Facility Inventory Database

The Facility Inventory Database (FID) contains a historical listing of active and inactive underground storage tank locations from the State Water Resource Control Board. Refer to local/county source for current data.

Date of Government Version: 10/31/1994	Source: California Environmental Protection Agency
Date Data Arrived at EDR: 09/05/1995	Telephone: 916-341-5851
Date Made Active in Reports: 09/29/1995	Last EDR Contact: 12/28/1998
Number of Days to Update: 24	Next Scheduled EDR Contact: N/A
	Data Release Frequency: No Update Planned

CERS TANKS: California Environmental Reporting System (CERS) Tanks

List of sites in the California Environmental Protection Agency (CalEPA) Regulated Site Portal which fall under the Aboveground Petroleum Storage and Underground Storage Tank regulatory programs.

Date of Government Version: 01/18/2022	Source: California Environmental Protection Agency
Date Data Arrived at EDR: 01/19/2022	Telephone: 916-323-2514
Date Made Active in Reports: 04/11/2022	Last EDR Contact: 04/19/2022
Number of Days to Update: 82	Next Scheduled EDR Contact: 08/01/2022
	Data Release Frequency: Quarterly

Local Land Records

LIENS: Environmental Liens Listing

A listing of property locations with environmental liens for California where DTSC is a lien holder.

Date of Government Version: 02/24/2022	Source: Department of Toxic Substances Control
Date Data Arrived at EDR: 02/25/2022	Telephone: 916-323-3400
Date Made Active in Reports: 03/09/2022	Last EDR Contact: 05/25/2022
Number of Days to Update: 12	Next Scheduled EDR Contact: 09/12/2022
	Data Release Frequency: Varies

LIENS 2: CERCLA Lien Information

A Federal CERCLA ('Superfund') lien can exist by operation of law at any site or property at which EPA has spent Superfund monies. These monies are spent to investigate and address releases and threatened releases of contamination. CERCLIS provides information as to the identity of these sites and properties.

Date of Government Version: 04/27/2022	Source: Environmental Protection Agency
Date Data Arrived at EDR: 05/05/2022	Telephone: 202-564-6023
Date Made Active in Reports: 05/31/2022	Last EDR Contact: 06/01/2022
Number of Days to Update: 26	Next Scheduled EDR Contact: 07/11/2022
	Data Release Frequency: Semi-Annually

GOVERNMENT RECORDS SEARCHED / DATA CURRENCY TRACKING

DEED: Deed Restriction Listing

Site Mitigation and Brownfields Reuse Program Facility Sites with Deed Restrictions & Hazardous Waste Management Program Facility Sites with Deed / Land Use Restriction. The DTSC Site Mitigation and Brownfields Reuse Program (SMBRP) list includes sites cleaned up under the program's oversight and generally does not include current or former hazardous waste facilities that required a hazardous waste facility permit. The list represents deed restrictions that are active. Some sites have multiple deed restrictions. The DTSC Hazardous Waste Management Program (HWMP) has developed a list of current or former hazardous waste facilities that have a recorded land use restriction at the local county recorder's office. The land use restrictions on this list were required by the DTSC HWMP as a result of the presence of hazardous substances that remain on site after the facility (or part of the facility) has been closed or cleaned up. The types of land use restriction include deed notice, deed restriction, or a land use restriction that binds current and future owners.

Date of Government Version: 02/28/2022	Source: DTSC and SWRCB
Date Data Arrived at EDR: 02/28/2022	Telephone: 916-323-3400
Date Made Active in Reports: 05/25/2022	Last EDR Contact: 05/31/2022
Number of Days to Update: 86	Next Scheduled EDR Contact: 09/12/2022
	Data Release Frequency: Semi-Annually

Records of Emergency Release Reports

HMIRS: Hazardous Materials Information Reporting System

Hazardous Materials Incident Report System. HMIRS contains hazardous material spill incidents reported to DOT.

Date of Government Version: 03/21/2022	Source: U.S. Department of Transportation
Date Data Arrived at EDR: 03/21/2022	Telephone: 202-366-4555
Date Made Active in Reports: 06/14/2022	Last EDR Contact: 03/21/2022
Number of Days to Update: 85	Next Scheduled EDR Contact: 07/04/2022
	Data Release Frequency: Quarterly

CHMIRS: California Hazardous Material Incident Report System

California Hazardous Material Incident Reporting System. CHMIRS contains information on reported hazardous material incidents (accidental releases or spills).

Date of Government Version: 12/31/2021	Source: Office of Emergency Services
Date Data Arrived at EDR: 01/19/2022	Telephone: 916-845-8400
Date Made Active in Reports: 04/08/2022	Last EDR Contact: 04/19/2022
Number of Days to Update: 79	Next Scheduled EDR Contact: 08/01/2022
	Data Release Frequency: Semi-Annually

LDS: Land Disposal Sites Listing (GEOTRACKER)

Land Disposal sites (Landfills) included in GeoTracker. GeoTracker is the Water Boards data management system for sites that impact, or have the potential to impact, water quality in California, with emphasis on groundwater.

Date of Government Version: 05/23/2022	Source: State Water Quality Control Board
Date Data Arrived at EDR: 05/23/2022	Telephone: 866-480-1028
Date Made Active in Reports: 05/24/2022	Last EDR Contact: 05/23/2022
Number of Days to Update: 1	Next Scheduled EDR Contact: 09/19/2022
	Data Release Frequency: Quarterly

MCS: Military Cleanup Sites Listing (GEOTRACKER)

Military sites (consisting of: Military UST sites; Military Privatized sites; and Military Cleanup sites [formerly known as DoD non UST]) included in GeoTracker. GeoTracker is the Water Boards data management system for sites that impact, or have the potential to impact, water quality in California, with emphasis on groundwater.

Date of Government Version: 05/23/2022	Source: State Water Resources Control Board
Date Data Arrived at EDR: 05/23/2022	Telephone: 866-480-1028
Date Made Active in Reports: 05/24/2022	Last EDR Contact: 05/23/2022
Number of Days to Update: 1	Next Scheduled EDR Contact: 09/19/2022
	Data Release Frequency: Quarterly

GOVERNMENT RECORDS SEARCHED / DATA CURRENCY TRACKING

SPILLS 90: SPILLS90 data from FirstSearch

Spills 90 includes those spill and release records available exclusively from FirstSearch databases. Typically, they may include chemical, oil and/or hazardous substance spills recorded after 1990. Duplicate records that are already included in EDR incident and release records are not included in Spills 90.

Date of Government Version: 06/06/2012	Source: FirstSearch
Date Data Arrived at EDR: 01/03/2013	Telephone: N/A
Date Made Active in Reports: 02/22/2013	Last EDR Contact: 01/03/2013
Number of Days to Update: 50	Next Scheduled EDR Contact: N/A
	Data Release Frequency: No Update Planned

Other Ascertainable Records

RCRA NonGen / NLR: RCRA - Non Generators / No Longer Regulated

RCRAInfo is EPA's comprehensive information system, providing access to data supporting the Resource Conservation and Recovery Act (RCRA) of 1976 and the Hazardous and Solid Waste Amendments (HSWA) of 1984. The database includes selective information on sites which generate, transport, store, treat and/or dispose of hazardous waste as defined by the Resource Conservation and Recovery Act (RCRA). Non-Generators do not presently generate hazardous waste.

Date of Government Version: 02/28/2022	Source: Environmental Protection Agency
Date Data Arrived at EDR: 03/02/2022	Telephone: (415) 495-8895
Date Made Active in Reports: 03/17/2022	Last EDR Contact: 04/06/2022
Number of Days to Update: 15	Next Scheduled EDR Contact: 07/04/2022
	Data Release Frequency: Quarterly

FUDS: Formerly Used Defense Sites

The listing includes locations of Formerly Used Defense Sites properties where the US Army Corps of Engineers is actively working or will take necessary cleanup actions.

Date of Government Version: 12/01/2021	Source: U.S. Army Corps of Engineers
Date Data Arrived at EDR: 02/15/2022	Telephone: 202-528-4285
Date Made Active in Reports: 05/10/2022	Last EDR Contact: 05/17/2022
Number of Days to Update: 84	Next Scheduled EDR Contact: 08/29/2022
	Data Release Frequency: Varies

DOD: Department of Defense Sites

This data set consists of federally owned or administered lands, administered by the Department of Defense, that have any area equal to or greater than 640 acres of the United States, Puerto Rico, and the U.S. Virgin Islands.

Date of Government Version: 06/07/2021	Source: USGS
Date Data Arrived at EDR: 07/13/2021	Telephone: 888-275-8747
Date Made Active in Reports: 03/09/2022	Last EDR Contact: 04/12/2022
Number of Days to Update: 239	Next Scheduled EDR Contact: 07/25/2022
	Data Release Frequency: Varies

FEDLAND: Federal and Indian Lands

Federally and Indian administrated lands of the United States. Lands included are administrated by: Army Corps of Engineers, Bureau of Reclamation, National Wild and Scenic River, National Wildlife Refuge, Public Domain Land, Wilderness, Wilderness Study Area, Wildlife Management Area, Bureau of Indian Affairs, Bureau of Land Management, Department of Justice, Forest Service, Fish and Wildlife Service, National Park Service.

Date of Government Version: 04/02/2018	Source: U.S. Geological Survey
Date Data Arrived at EDR: 04/11/2018	Telephone: 888-275-8747
Date Made Active in Reports: 11/06/2019	Last EDR Contact: 04/05/2022
Number of Days to Update: 574	Next Scheduled EDR Contact: 07/18/2022
	Data Release Frequency: N/A

SCRD DRYCLEANERS: State Coalition for Remediation of Drycleaners Listing

The State Coalition for Remediation of Drycleaners was established in 1998, with support from the U.S. EPA Office of Superfund Remediation and Technology Innovation. It is comprised of representatives of states with established drycleaner remediation programs. Currently the member states are Alabama, Connecticut, Florida, Illinois, Kansas, Minnesota, Missouri, North Carolina, Oregon, South Carolina, Tennessee, Texas, and Wisconsin.

GOVERNMENT RECORDS SEARCHED / DATA CURRENCY TRACKING

Date of Government Version: 01/01/2017
Date Data Arrived at EDR: 02/03/2017
Date Made Active in Reports: 04/07/2017
Number of Days to Update: 63

Source: Environmental Protection Agency
Telephone: 615-532-8599
Last EDR Contact: 05/06/2022
Next Scheduled EDR Contact: 08/22/2022
Data Release Frequency: Varies

US FIN ASSUR: Financial Assurance Information

All owners and operators of facilities that treat, store, or dispose of hazardous waste are required to provide proof that they will have sufficient funds to pay for the clean up, closure, and post-closure care of their facilities.

Date of Government Version: 03/21/2022
Date Data Arrived at EDR: 03/21/2022
Date Made Active in Reports: 06/14/2022
Number of Days to Update: 85

Source: Environmental Protection Agency
Telephone: 202-566-1917
Last EDR Contact: 03/21/2022
Next Scheduled EDR Contact: 07/04/2022
Data Release Frequency: Quarterly

EPA WATCH LIST: EPA WATCH LIST

EPA maintains a "Watch List" to facilitate dialogue between EPA, state and local environmental agencies on enforcement matters relating to facilities with alleged violations identified as either significant or high priority. Being on the Watch List does not mean that the facility has actually violated the law only that an investigation by EPA or a state or local environmental agency has led those organizations to allege that an unproven violation has in fact occurred. Being on the Watch List does not represent a higher level of concern regarding the alleged violations that were detected, but instead indicates cases requiring additional dialogue between EPA, state and local agencies - primarily because of the length of time the alleged violation has gone unaddressed or unresolved.

Date of Government Version: 08/30/2013
Date Data Arrived at EDR: 03/21/2014
Date Made Active in Reports: 06/17/2014
Number of Days to Update: 88

Source: Environmental Protection Agency
Telephone: 617-520-3000
Last EDR Contact: 04/28/2022
Next Scheduled EDR Contact: 08/15/2022
Data Release Frequency: Quarterly

2020 COR ACTION: 2020 Corrective Action Program List

The EPA has set ambitious goals for the RCRA Corrective Action program by creating the 2020 Corrective Action Universe. This RCRA cleanup baseline includes facilities expected to need corrective action. The 2020 universe contains a wide variety of sites. Some properties are heavily contaminated while others were contaminated but have since been cleaned up. Still others have not been fully investigated yet, and may require little or no remediation. Inclusion in the 2020 Universe does not necessarily imply failure on the part of a facility to meet its RCRA obligations.

Date of Government Version: 09/30/2017
Date Data Arrived at EDR: 05/08/2018
Date Made Active in Reports: 07/20/2018
Number of Days to Update: 73

Source: Environmental Protection Agency
Telephone: 703-308-4044
Last EDR Contact: 05/06/2022
Next Scheduled EDR Contact: 08/15/2022
Data Release Frequency: Varies

TSCA: Toxic Substances Control Act

Toxic Substances Control Act. TSCA identifies manufacturers and importers of chemical substances included on the TSCA Chemical Substance Inventory list. It includes data on the production volume of these substances by plant site.

Date of Government Version: 12/31/2016
Date Data Arrived at EDR: 06/17/2020
Date Made Active in Reports: 09/10/2020
Number of Days to Update: 85

Source: EPA
Telephone: 202-260-5521
Last EDR Contact: 06/14/2022
Next Scheduled EDR Contact: 09/26/2022
Data Release Frequency: Every 4 Years

TRIS: Toxic Chemical Release Inventory System

Toxic Release Inventory System. TRIS identifies facilities which release toxic chemicals to the air, water and land in reportable quantities under SARA Title III Section 313.

GOVERNMENT RECORDS SEARCHED / DATA CURRENCY TRACKING

Date of Government Version: 12/31/2018
Date Data Arrived at EDR: 08/14/2020
Date Made Active in Reports: 11/04/2020
Number of Days to Update: 82

Source: EPA
Telephone: 202-566-0250
Last EDR Contact: 05/20/2022
Next Scheduled EDR Contact: 08/29/2022
Data Release Frequency: Annually

SSTS: Section 7 Tracking Systems

Section 7 of the Federal Insecticide, Fungicide and Rodenticide Act, as amended (92 Stat. 829) requires all registered pesticide-producing establishments to submit a report to the Environmental Protection Agency by March 1st each year. Each establishment must report the types and amounts of pesticides, active ingredients and devices being produced, and those having been produced and sold or distributed in the past year.

Date of Government Version: 01/19/2022
Date Data Arrived at EDR: 01/19/2022
Date Made Active in Reports: 04/11/2022
Number of Days to Update: 82

Source: EPA
Telephone: 202-564-4203
Last EDR Contact: 04/20/2022
Next Scheduled EDR Contact: 08/01/2022
Data Release Frequency: Annually

ROD: Records Of Decision

Record of Decision. ROD documents mandate a permanent remedy at an NPL (Superfund) site containing technical and health information to aid in the cleanup.

Date of Government Version: 04/27/2022
Date Data Arrived at EDR: 05/05/2022
Date Made Active in Reports: 05/31/2022
Number of Days to Update: 26

Source: EPA
Telephone: 703-416-0223
Last EDR Contact: 06/01/2022
Next Scheduled EDR Contact: 09/12/2022
Data Release Frequency: Annually

RMP: Risk Management Plans

When Congress passed the Clean Air Act Amendments of 1990, it required EPA to publish regulations and guidance for chemical accident prevention at facilities using extremely hazardous substances. The Risk Management Program Rule (RMP Rule) was written to implement Section 112(r) of these amendments. The rule, which built upon existing industry codes and standards, requires companies of all sizes that use certain flammable and toxic substances to develop a Risk Management Program, which includes a(n): Hazard assessment that details the potential effects of an accidental release, an accident history of the last five years, and an evaluation of worst-case and alternative accidental releases; Prevention program that includes safety precautions and maintenance, monitoring, and employee training measures; and Emergency response program that spells out emergency health care, employee training measures and procedures for informing the public and response agencies (e.g the fire department) should an accident occur.

Date of Government Version: 04/27/2022
Date Data Arrived at EDR: 05/04/2022
Date Made Active in Reports: 05/10/2022
Number of Days to Update: 6

Source: Environmental Protection Agency
Telephone: 202-564-8600
Last EDR Contact: 04/18/2022
Next Scheduled EDR Contact: 08/01/2022
Data Release Frequency: Varies

RAATS: RCRA Administrative Action Tracking System

RCRA Administration Action Tracking System. RAATS contains records based on enforcement actions issued under RCRA pertaining to major violators and includes administrative and civil actions brought by the EPA. For administration actions after September 30, 1995, data entry in the RAATS database was discontinued. EPA will retain a copy of the database for historical records. It was necessary to terminate RAATS because a decrease in agency resources made it impossible to continue to update the information contained in the database.

Date of Government Version: 04/17/1995
Date Data Arrived at EDR: 07/03/1995
Date Made Active in Reports: 08/07/1995
Number of Days to Update: 35

Source: EPA
Telephone: 202-564-4104
Last EDR Contact: 06/02/2008
Next Scheduled EDR Contact: 09/01/2008
Data Release Frequency: No Update Planned

GOVERNMENT RECORDS SEARCHED / DATA CURRENCY TRACKING

PRP: Potentially Responsible Parties

A listing of verified Potentially Responsible Parties

Date of Government Version: 01/25/2022	Source: EPA
Date Data Arrived at EDR: 02/03/2022	Telephone: 202-564-6023
Date Made Active in Reports: 02/25/2022	Last EDR Contact: 06/01/2022
Number of Days to Update: 22	Next Scheduled EDR Contact: 08/15/2022
	Data Release Frequency: Quarterly

PADS: PCB Activity Database System

PCB Activity Database. PADS Identifies generators, transporters, commercial storers and/or brokers and disposers of PCB's who are required to notify the EPA of such activities.

Date of Government Version: 01/20/2022	Source: EPA
Date Data Arrived at EDR: 01/20/2022	Telephone: 202-566-0500
Date Made Active in Reports: 03/25/2022	Last EDR Contact: 04/08/2022
Number of Days to Update: 64	Next Scheduled EDR Contact: 07/18/2022
	Data Release Frequency: Annually

ICIS: Integrated Compliance Information System

The Integrated Compliance Information System (ICIS) supports the information needs of the national enforcement and compliance program as well as the unique needs of the National Pollutant Discharge Elimination System (NPDES) program.

Date of Government Version: 11/18/2016	Source: Environmental Protection Agency
Date Data Arrived at EDR: 11/23/2016	Telephone: 202-564-2501
Date Made Active in Reports: 02/10/2017	Last EDR Contact: 03/31/2022
Number of Days to Update: 79	Next Scheduled EDR Contact: 07/18/2022
	Data Release Frequency: Quarterly

FTTS: FIFRA/ TSCA Tracking System - FIFRA (Federal Insecticide, Fungicide, & Rodenticide Act)/TSCA (Toxic Substances Control Act)

FTTS tracks administrative cases and pesticide enforcement actions and compliance activities related to FIFRA, TSCA and EPCRA (Emergency Planning and Community Right-to-Know Act). To maintain currency, EDR contacts the Agency on a quarterly basis.

Date of Government Version: 04/09/2009	Source: EPA/Office of Prevention, Pesticides and Toxic Substances
Date Data Arrived at EDR: 04/16/2009	Telephone: 202-566-1667
Date Made Active in Reports: 05/11/2009	Last EDR Contact: 08/18/2017
Number of Days to Update: 25	Next Scheduled EDR Contact: 12/04/2017
	Data Release Frequency: No Update Planned

FTTS INSP: FIFRA/ TSCA Tracking System - FIFRA (Federal Insecticide, Fungicide, & Rodenticide Act)/TSCA (Toxic Substances Control Act)

A listing of FIFRA/TSCA Tracking System (FTTS) inspections and enforcements.

Date of Government Version: 04/09/2009	Source: EPA
Date Data Arrived at EDR: 04/16/2009	Telephone: 202-566-1667
Date Made Active in Reports: 05/11/2009	Last EDR Contact: 08/18/2017
Number of Days to Update: 25	Next Scheduled EDR Contact: 12/04/2017
	Data Release Frequency: No Update Planned

MLTS: Material Licensing Tracking System

MLTS is maintained by the Nuclear Regulatory Commission and contains a list of approximately 8,100 sites which possess or use radioactive materials and which are subject to NRC licensing requirements. To maintain currency, EDR contacts the Agency on a quarterly basis.

Date of Government Version: 03/11/2022	Source: Nuclear Regulatory Commission
Date Data Arrived at EDR: 03/15/2022	Telephone: 301-415-7169
Date Made Active in Reports: 06/14/2022	Last EDR Contact: 04/18/2022
Number of Days to Update: 91	Next Scheduled EDR Contact: 08/01/2022
	Data Release Frequency: Quarterly

GOVERNMENT RECORDS SEARCHED / DATA CURRENCY TRACKING

COAL ASH DOE: Steam-Electric Plant Operation Data

A listing of power plants that store ash in surface ponds.

Date of Government Version: 12/31/2020	Source: Department of Energy
Date Data Arrived at EDR: 11/30/2021	Telephone: 202-586-8719
Date Made Active in Reports: 02/22/2022	Last EDR Contact: 06/02/2022
Number of Days to Update: 84	Next Scheduled EDR Contact: 09/12/2022
	Data Release Frequency: Varies

COAL ASH EPA: Coal Combustion Residues Surface Impoundments List

A listing of coal combustion residues surface impoundments with high hazard potential ratings.

Date of Government Version: 01/12/2017	Source: Environmental Protection Agency
Date Data Arrived at EDR: 03/05/2019	Telephone: N/A
Date Made Active in Reports: 11/11/2019	Last EDR Contact: 05/25/2022
Number of Days to Update: 251	Next Scheduled EDR Contact: 09/12/2022
	Data Release Frequency: Varies

PCB TRANSFORMER: PCB Transformer Registration Database

The database of PCB transformer registrations that includes all PCB registration submittals.

Date of Government Version: 09/13/2019	Source: Environmental Protection Agency
Date Data Arrived at EDR: 11/06/2019	Telephone: 202-566-0517
Date Made Active in Reports: 02/10/2020	Last EDR Contact: 05/06/2022
Number of Days to Update: 96	Next Scheduled EDR Contact: 08/15/2022
	Data Release Frequency: Varies

RADINFO: Radiation Information Database

The Radiation Information Database (RADINFO) contains information about facilities that are regulated by U.S. Environmental Protection Agency (EPA) regulations for radiation and radioactivity.

Date of Government Version: 07/01/2019	Source: Environmental Protection Agency
Date Data Arrived at EDR: 07/01/2019	Telephone: 202-343-9775
Date Made Active in Reports: 09/23/2019	Last EDR Contact: 03/28/2022
Number of Days to Update: 84	Next Scheduled EDR Contact: 07/11/2022
	Data Release Frequency: Quarterly

HIST FTTS: FIFRA/TSCA Tracking System Administrative Case Listing

A complete administrative case listing from the FIFRA/TSCA Tracking System (FTTS) for all ten EPA regions. The information was obtained from the National Compliance Database (NCDB). NCDB supports the implementation of FIFRA (Federal Insecticide, Fungicide, and Rodenticide Act) and TSCA (Toxic Substances Control Act). Some EPA regions are now closing out records. Because of that, and the fact that some EPA regions are not providing EPA Headquarters with updated records, it was decided to create a HIST FTTS database. It included records that may not be included in the newer FTTS database updates. This database is no longer updated.

Date of Government Version: 10/19/2006	Source: Environmental Protection Agency
Date Data Arrived at EDR: 03/01/2007	Telephone: 202-564-2501
Date Made Active in Reports: 04/10/2007	Last EDR Contact: 12/17/2007
Number of Days to Update: 40	Next Scheduled EDR Contact: 03/17/2008
	Data Release Frequency: No Update Planned

HIST FTTS INSP: FIFRA/TSCA Tracking System Inspection & Enforcement Case Listing

A complete inspection and enforcement case listing from the FIFRA/TSCA Tracking System (FTTS) for all ten EPA regions. The information was obtained from the National Compliance Database (NCDB). NCDB supports the implementation of FIFRA (Federal Insecticide, Fungicide, and Rodenticide Act) and TSCA (Toxic Substances Control Act). Some EPA regions are now closing out records. Because of that, and the fact that some EPA regions are not providing EPA Headquarters with updated records, it was decided to create a HIST FTTS database. It included records that may not be included in the newer FTTS database updates. This database is no longer updated.

GOVERNMENT RECORDS SEARCHED / DATA CURRENCY TRACKING

Date of Government Version: 10/19/2006
Date Data Arrived at EDR: 03/01/2007
Date Made Active in Reports: 04/10/2007
Number of Days to Update: 40

Source: Environmental Protection Agency
Telephone: 202-564-2501
Last EDR Contact: 12/17/2008
Next Scheduled EDR Contact: 03/17/2008
Data Release Frequency: No Update Planned

DOT OPS: Incident and Accident Data

Department of Transportation, Office of Pipeline Safety Incident and Accident data.

Date of Government Version: 01/02/2020
Date Data Arrived at EDR: 01/28/2020
Date Made Active in Reports: 04/17/2020
Number of Days to Update: 80

Source: Department of Transportation, Office of Pipeline Safety
Telephone: 202-366-4595
Last EDR Contact: 04/26/2022
Next Scheduled EDR Contact: 08/08/2022
Data Release Frequency: Quarterly

CONSENT: Superfund (CERCLA) Consent Decrees

Major legal settlements that establish responsibility and standards for cleanup at NPL (Superfund) sites. Released periodically by United States District Courts after settlement by parties to litigation matters.

Date of Government Version: 12/31/2021
Date Data Arrived at EDR: 01/14/2022
Date Made Active in Reports: 03/25/2022
Number of Days to Update: 70

Source: Department of Justice, Consent Decree Library
Telephone: Varies
Last EDR Contact: 04/04/2022
Next Scheduled EDR Contact: 07/18/2022
Data Release Frequency: Varies

BRS: Biennial Reporting System

The Biennial Reporting System is a national system administered by the EPA that collects data on the generation and management of hazardous waste. BRS captures detailed data from two groups: Large Quantity Generators (LQG) and Treatment, Storage, and Disposal Facilities.

Date of Government Version: 12/31/2019
Date Data Arrived at EDR: 03/02/2022
Date Made Active in Reports: 03/25/2022
Number of Days to Update: 23

Source: EPA/NTIS
Telephone: 800-424-9346
Last EDR Contact: 03/02/2022
Next Scheduled EDR Contact: 07/04/2022
Data Release Frequency: Biennially

INDIAN RESERV: Indian Reservations

This map layer portrays Indian administered lands of the United States that have any area equal to or greater than 640 acres.

Date of Government Version: 12/31/2014
Date Data Arrived at EDR: 07/14/2015
Date Made Active in Reports: 01/10/2017
Number of Days to Update: 546

Source: USGS
Telephone: 202-208-3710
Last EDR Contact: 04/05/2022
Next Scheduled EDR Contact: 07/18/2022
Data Release Frequency: Semi-Annually

FUSRAP: Formerly Utilized Sites Remedial Action Program

DOE established the Formerly Utilized Sites Remedial Action Program (FUSRAP) in 1974 to remediate sites where radioactive contamination remained from Manhattan Project and early U.S. Atomic Energy Commission (AEC) operations.

Date of Government Version: 07/26/2021
Date Data Arrived at EDR: 07/27/2021
Date Made Active in Reports: 10/22/2021
Number of Days to Update: 87

Source: Department of Energy
Telephone: 202-586-3559
Last EDR Contact: 04/28/2022
Next Scheduled EDR Contact: 08/15/2022
Data Release Frequency: Varies

UMTRA: Uranium Mill Tailings Sites

Uranium ore was mined by private companies for federal government use in national defense programs. When the mills shut down, large piles of the sand-like material (mill tailings) remain after uranium has been extracted from the ore. Levels of human exposure to radioactive materials from the piles are low; however, in some cases tailings were used as construction materials before the potential health hazards of the tailings were recognized.

GOVERNMENT RECORDS SEARCHED / DATA CURRENCY TRACKING

Date of Government Version: 08/30/2019
Date Data Arrived at EDR: 11/15/2019
Date Made Active in Reports: 01/28/2020
Number of Days to Update: 74

Source: Department of Energy
Telephone: 505-845-0011
Last EDR Contact: 05/16/2022
Next Scheduled EDR Contact: 08/29/2022
Data Release Frequency: Varies

LEAD SMELTER 1: Lead Smelter Sites

A listing of former lead smelter site locations.

Date of Government Version: 04/27/2022
Date Data Arrived at EDR: 05/05/2022
Date Made Active in Reports: 05/31/2022
Number of Days to Update: 26

Source: Environmental Protection Agency
Telephone: 703-603-8787
Last EDR Contact: 09/01/2022
Next Scheduled EDR Contact: 07/11/2022
Data Release Frequency: Varies

LEAD SMELTER 2: Lead Smelter Sites

A list of several hundred sites in the U.S. where secondary lead smelting was done from 1931 and 1964. These sites may pose a threat to public health through ingestion or inhalation of contaminated soil or dust.

Date of Government Version: 04/05/2001
Date Data Arrived at EDR: 10/27/2010
Date Made Active in Reports: 12/02/2010
Number of Days to Update: 36

Source: American Journal of Public Health
Telephone: 703-305-6451
Last EDR Contact: 12/02/2009
Next Scheduled EDR Contact: N/A
Data Release Frequency: No Update Planned

US AIRS (AFS): Aerometric Information Retrieval System Facility Subsystem (AFS)

The database is a sub-system of Aerometric Information Retrieval System (AIRS). AFS contains compliance data on air pollution point sources regulated by the U.S. EPA and/or state and local air regulatory agencies. This information comes from source reports by various stationary sources of air pollution, such as electric power plants, steel mills, factories, and universities, and provides information about the air pollutants they produce. Action, air program, air program pollutant, and general level plant data. It is used to track emissions and compliance data from industrial plants.

Date of Government Version: 10/12/2016
Date Data Arrived at EDR: 10/26/2016
Date Made Active in Reports: 02/03/2017
Number of Days to Update: 100

Source: EPA
Telephone: 202-564-2496
Last EDR Contact: 09/26/2017
Next Scheduled EDR Contact: 01/08/2018
Data Release Frequency: Annually

US AIRS MINOR: Air Facility System Data

A listing of minor source facilities.

Date of Government Version: 10/12/2016
Date Data Arrived at EDR: 10/26/2016
Date Made Active in Reports: 02/03/2017
Number of Days to Update: 100

Source: EPA
Telephone: 202-564-2496
Last EDR Contact: 09/26/2017
Next Scheduled EDR Contact: 01/08/2018
Data Release Frequency: Annually

US MINES: Mines Master Index File

Contains all mine identification numbers issued for mines active or opened since 1971. The data also includes violation information.

Date of Government Version: 02/01/2022
Date Data Arrived at EDR: 02/23/2022
Date Made Active in Reports: 05/24/2022
Number of Days to Update: 90

Source: Department of Labor, Mine Safety and Health Administration
Telephone: 303-231-5959
Last EDR Contact: 05/25/2022
Next Scheduled EDR Contact: 09/05/2022
Data Release Frequency: Semi-Annually

MINES VIOLATIONS: MSHA Violation Assessment Data

Mines violation and assessment information. Department of Labor, Mine Safety & Health Administration.

GOVERNMENT RECORDS SEARCHED / DATA CURRENCY TRACKING

Date of Government Version: 03/21/2022
Date Data Arrived at EDR: 03/22/2022
Date Made Active in Reports: 03/25/2022
Number of Days to Update: 3

Source: DOL, Mine Safety & Health Admi
Telephone: 202-693-9424
Last EDR Contact: 05/26/2022
Next Scheduled EDR Contact: 09/12/2022
Data Release Frequency: Quarterly

US MINES 2: Ferrous and Nonferrous Metal Mines Database Listing

This map layer includes ferrous (ferrous metal mines are facilities that extract ferrous metals, such as iron ore or molybdenum) and nonferrous (Nonferrous metal mines are facilities that extract nonferrous metals, such as gold, silver, copper, zinc, and lead) metal mines in the United States.

Date of Government Version: 05/06/2020
Date Data Arrived at EDR: 05/27/2020
Date Made Active in Reports: 08/13/2020
Number of Days to Update: 78

Source: USGS
Telephone: 703-648-7709
Last EDR Contact: 05/27/2022
Next Scheduled EDR Contact: 09/05/2022
Data Release Frequency: Varies

US MINES 3: Active Mines & Mineral Plants Database Listing

Active Mines and Mineral Processing Plant operations for commodities monitored by the Minerals Information Team of the USGS.

Date of Government Version: 04/14/2011
Date Data Arrived at EDR: 06/08/2011
Date Made Active in Reports: 09/13/2011
Number of Days to Update: 97

Source: USGS
Telephone: 703-648-7709
Last EDR Contact: 05/27/2022
Next Scheduled EDR Contact: 09/05/2022
Data Release Frequency: Varies

ABANDONED MINES: Abandoned Mines

An inventory of land and water impacted by past mining (primarily coal mining) is maintained by OSMRE to provide information needed to implement the Surface Mining Control and Reclamation Act of 1977 (SMCRA). The inventory contains information on the location, type, and extent of AML impacts, as well as, information on the cost associated with the reclamation of those problems. The inventory is based upon field surveys by State, Tribal, and OSMRE program officials. It is dynamic to the extent that it is modified as new problems are identified and existing problems are reclaimed.

Date of Government Version: 03/10/2022
Date Data Arrived at EDR: 03/10/2022
Date Made Active in Reports: 06/14/2022
Number of Days to Update: 96

Source: Department of Interior
Telephone: 202-208-2609
Last EDR Contact: 06/14/2022
Next Scheduled EDR Contact: 09/19/2022
Data Release Frequency: Quarterly

FINDS: Facility Index System/Facility Registry System

Facility Index System. FINDS contains both facility information and 'pointers' to other sources that contain more detail. EDR includes the following FINDS databases in this report: PCS (Permit Compliance System), AIRS (Aerometric Information Retrieval System), DOCKET (Enforcement Docket used to manage and track information on civil judicial enforcement cases for all environmental statutes), FURS (Federal Underground Injection Control), C-DOCKET (Criminal Docket System used to track criminal enforcement actions for all environmental statutes), FFIS (Federal Facilities Information System), STATE (State Environmental Laws and Statutes), and PADS (PCB Activity Data System).

Date of Government Version: 05/13/2022
Date Data Arrived at EDR: 05/18/2022
Date Made Active in Reports: 05/31/2022
Number of Days to Update: 13

Source: EPA
Telephone: (415) 947-8000
Last EDR Contact: 05/18/2022
Next Scheduled EDR Contact: 09/12/2022
Data Release Frequency: Quarterly

DOCKET HWC: Hazardous Waste Compliance Docket Listing

A complete list of the Federal Agency Hazardous Waste Compliance Docket Facilities.

Date of Government Version: 05/06/2021
Date Data Arrived at EDR: 05/21/2021
Date Made Active in Reports: 08/11/2021
Number of Days to Update: 82

Source: Environmental Protection Agency
Telephone: 202-564-0527
Last EDR Contact: 05/19/2022
Next Scheduled EDR Contact: 09/05/2022
Data Release Frequency: Varies

GOVERNMENT RECORDS SEARCHED / DATA CURRENCY TRACKING

UXO: Unexploded Ordnance Sites

A listing of unexploded ordnance site locations

Date of Government Version: 12/31/2020	Source: Department of Defense
Date Data Arrived at EDR: 01/11/2022	Telephone: 703-704-1564
Date Made Active in Reports: 02/14/2022	Last EDR Contact: 04/12/2022
Number of Days to Update: 34	Next Scheduled EDR Contact: 07/25/2022
	Data Release Frequency: Varies

ECHO: Enforcement & Compliance History Information

ECHO provides integrated compliance and enforcement information for about 800,000 regulated facilities nationwide.

Date of Government Version: 01/01/2022	Source: Environmental Protection Agency
Date Data Arrived at EDR: 01/04/2022	Telephone: 202-564-2280
Date Made Active in Reports: 01/10/2022	Last EDR Contact: 04/05/2022
Number of Days to Update: 6	Next Scheduled EDR Contact: 07/18/2022
	Data Release Frequency: Quarterly

FUELS PROGRAM: EPA Fuels Program Registered Listing

This listing includes facilities that are registered under the Part 80 (Code of Federal Regulations) EPA Fuels Programs. All companies now are required to submit new and updated registrations.

Date of Government Version: 02/17/2022	Source: EPA
Date Data Arrived at EDR: 02/17/2022	Telephone: 800-385-6164
Date Made Active in Reports: 05/10/2022	Last EDR Contact: 05/17/2022
Number of Days to Update: 82	Next Scheduled EDR Contact: 08/29/2022
	Data Release Frequency: Quarterly

CA BOND EXP. PLAN: Bond Expenditure Plan

Department of Health Services developed a site-specific expenditure plan as the basis for an appropriation of Hazardous Substance Cleanup Bond Act funds. It is not updated.

Date of Government Version: 01/01/1989	Source: Department of Health Services
Date Data Arrived at EDR: 07/27/1994	Telephone: 916-255-2118
Date Made Active in Reports: 08/02/1994	Last EDR Contact: 05/31/1994
Number of Days to Update: 6	Next Scheduled EDR Contact: N/A
	Data Release Frequency: No Update Planned

CORTESE: "Cortese" Hazardous Waste & Substances Sites List

The sites for the list are designated by the State Water Resource Control Board (LUST), the Integrated Waste Board (SWF/LS), and the Department of Toxic Substances Control (Cal-Sites).

Date of Government Version: 03/21/2022	Source: CAL EPA/Office of Emergency Information
Date Data Arrived at EDR: 03/21/2022	Telephone: 916-323-3400
Date Made Active in Reports: 06/14/2022	Last EDR Contact: 03/21/2022
Number of Days to Update: 85	Next Scheduled EDR Contact: 07/04/2022
	Data Release Frequency: Quarterly

CUPA LIVERMORE-PLEASANTON: CUPA Facility Listing

list of facilities associated with the various CUPA programs in Livermore-Pleasanton

Date of Government Version: 12/07/2021	Source: Livermore-Pleasanton Fire Department
Date Data Arrived at EDR: 05/09/2022	Telephone: 925-454-2361
Date Made Active in Reports: 05/17/2022	Last EDR Contact: 05/09/2022
Number of Days to Update: 8	Next Scheduled EDR Contact: 08/22/2022
	Data Release Frequency: Varies

DRYCLEAN AVAQMD: Antelope Valley Air Quality Management District Drycleaner Listing

A listing of dry cleaners in the Antelope Valley Air Quality Management District.

GOVERNMENT RECORDS SEARCHED / DATA CURRENCY TRACKING

Date of Government Version: 02/24/2022
Date Data Arrived at EDR: 02/25/2022
Date Made Active in Reports: 05/18/2022
Number of Days to Update: 82

Source: Antelope Valley Air Quality Management District
Telephone: 661-723-8070
Last EDR Contact: 05/25/2022
Next Scheduled EDR Contact: 09/12/2022
Data Release Frequency: Varies

DRYCLEAN SOUTH COAST: South Coast Air Quality Management District Drycleaner Listing

A listing of dry cleaners in the South Coast Air Quality Management District

Date of Government Version: 02/17/2022
Date Data Arrived at EDR: 02/24/2022
Date Made Active in Reports: 05/18/2022
Number of Days to Update: 83

Source: South Coast Air Quality Management District
Telephone: 909-396-3211
Last EDR Contact: 05/19/2022
Next Scheduled EDR Contact: 09/05/2022
Data Release Frequency: Varies

DRYCLEANERS: Cleaner Facilities

A list of drycleaner related facilities that have EPA ID numbers. These are facilities with certain SIC codes: power laundries, family and commercial; garment pressing and cleaner's agents; linen supply; coin-operated laundries and cleaning; drycleaning plants, except rugs; carpet and upholster cleaning; industrial launderers; laundry and garment services.

Date of Government Version: 08/27/2021
Date Data Arrived at EDR: 09/01/2021
Date Made Active in Reports: 11/19/2021
Number of Days to Update: 79

Source: Department of Toxic Substance Control
Telephone: 916-327-4498
Last EDR Contact: 06/01/2022
Next Scheduled EDR Contact: 09/12/2022
Data Release Frequency: Annually

EMI: Emissions Inventory Data

Toxics and criteria pollutant emissions data collected by the ARB and local air pollution agencies.

Date of Government Version: 12/31/2019
Date Data Arrived at EDR: 06/10/2021
Date Made Active in Reports: 08/27/2021
Number of Days to Update: 78

Source: California Air Resources Board
Telephone: 916-322-2990
Last EDR Contact: 06/13/2022
Next Scheduled EDR Contact: 09/26/2022
Data Release Frequency: Varies

ENF: Enforcement Action Listing

A listing of Water Board Enforcement Actions. Formal is everything except Oral/Verbal Communication, Notice of Violation, Expedited Payment Letter, and Staff Enforcement Letter.

Date of Government Version: 04/12/2022
Date Data Arrived at EDR: 04/19/2022
Date Made Active in Reports: 05/31/2022
Number of Days to Update: 42

Source: State Water Resources Control Board
Telephone: 916-445-9379
Last EDR Contact: 04/19/2022
Next Scheduled EDR Contact: 08/01/2022
Data Release Frequency: Varies

Financial Assurance 1: Financial Assurance Information Listing

Financial Assurance information

Date of Government Version: 01/13/2022
Date Data Arrived at EDR: 01/14/2022
Date Made Active in Reports: 04/08/2022
Number of Days to Update: 84

Source: Department of Toxic Substances Control
Telephone: 916-255-3628
Last EDR Contact: 04/28/2022
Next Scheduled EDR Contact: 08/01/2022
Data Release Frequency: Varies

Financial Assurance 2: Financial Assurance Information Listing

A listing of financial assurance information for solid waste facilities. Financial assurance is intended to ensure that resources are available to pay for the cost of closure, post-closure care, and corrective measures if the owner or operator of a regulated facility is unable or unwilling to pay.

GOVERNMENT RECORDS SEARCHED / DATA CURRENCY TRACKING

Date of Government Version: 02/23/2022
Date Data Arrived at EDR: 02/24/2022
Date Made Active in Reports: 05/18/2022
Number of Days to Update: 83

Source: California Integrated Waste Management Board
Telephone: 916-341-6066
Last EDR Contact: 05/19/2022
Next Scheduled EDR Contact: 08/22/2022
Data Release Frequency: Varies

HAZNET: Facility and Manifest Data

Facility and Manifest Data. The data is extracted from the copies of hazardous waste manifests received each year by the DTSC. The annual volume of manifests is typically 700,000 - 1,000,000 annually, representing approximately 350,000 - 500,000 shipments. Data are from the manifests submitted without correction, and therefore many contain some invalid values for data elements such as generator ID, TSD ID, waste category, and disposal method. This database begins with calendar year 1993.

Date of Government Version: 12/31/2019
Date Data Arrived at EDR: 04/15/2020
Date Made Active in Reports: 07/02/2020
Number of Days to Update: 78

Source: California Environmental Protection Agency
Telephone: 916-255-1136
Last EDR Contact: 04/08/2022
Next Scheduled EDR Contact: 07/18/2022
Data Release Frequency: Annually

ICE: ICE

Contains data pertaining to the Permitted Facilities with Inspections / Enforcements sites tracked in Envirostor.

Date of Government Version: 02/14/2022
Date Data Arrived at EDR: 02/15/2022
Date Made Active in Reports: 05/12/2022
Number of Days to Update: 86

Source: Department of Toxic Substances Control
Telephone: 877-786-9427
Last EDR Contact: 05/17/2022
Next Scheduled EDR Contact: 08/29/2022
Data Release Frequency: Quarterly

HIST CORTESE: Hazardous Waste & Substance Site List

The sites for the list are designated by the State Water Resource Control Board [LUST], the Integrated Waste Board [SWF/LS], and the Department of Toxic Substances Control [CALSITES]. This listing is no longer updated by the state agency.

Date of Government Version: 04/01/2001
Date Data Arrived at EDR: 01/22/2009
Date Made Active in Reports: 04/08/2009
Number of Days to Update: 76

Source: Department of Toxic Substances Control
Telephone: 916-323-3400
Last EDR Contact: 01/22/2009
Next Scheduled EDR Contact: N/A
Data Release Frequency: No Update Planned

HWP: EnviroStor Permitted Facilities Listing

Detailed information on permitted hazardous waste facilities and corrective action ("cleanups") tracked in EnviroStor.

Date of Government Version: 02/14/2022
Date Data Arrived at EDR: 02/15/2022
Date Made Active in Reports: 05/12/2022
Number of Days to Update: 86

Source: Department of Toxic Substances Control
Telephone: 916-323-3400
Last EDR Contact: 05/17/2022
Next Scheduled EDR Contact: 08/29/2022
Data Release Frequency: Quarterly

HWT: Registered Hazardous Waste Transporter Database

A listing of hazardous waste transporters. In California, unless specifically exempted, it is unlawful for any person to transport hazardous wastes unless the person holds a valid registration issued by DTSC. A hazardous waste transporter registration is valid for one year and is assigned a unique registration number.

Date of Government Version: 01/03/2022
Date Data Arrived at EDR: 01/04/2022
Date Made Active in Reports: 03/18/2022
Number of Days to Update: 73

Source: Department of Toxic Substances Control
Telephone: 916-440-7145
Last EDR Contact: 04/05/2022
Next Scheduled EDR Contact: 07/18/2022
Data Release Frequency: Quarterly

GOVERNMENT RECORDS SEARCHED / DATA CURRENCY TRACKING

MINES: Mines Site Location Listing

A listing of mine site locations from the Office of Mine Reclamation.

Date of Government Version: 03/07/2022	Source: Department of Conservation
Date Data Arrived at EDR: 03/08/2022	Telephone: 916-322-1080
Date Made Active in Reports: 06/01/2022	Last EDR Contact: 06/07/2022
Number of Days to Update: 85	Next Scheduled EDR Contact: 09/19/2022
	Data Release Frequency: Quarterly

MWMP: Medical Waste Management Program Listing

The Medical Waste Management Program (MWMP) ensures the proper handling and disposal of medical waste by permitting and inspecting medical waste Offsite Treatment Facilities (PDF) and Transfer Stations (PDF) throughout the state. MWMP also oversees all Medical Waste Transporters.

Date of Government Version: 02/17/2022	Source: Department of Public Health
Date Data Arrived at EDR: 02/28/2022	Telephone: 916-558-1784
Date Made Active in Reports: 05/25/2022	Last EDR Contact: 05/31/2022
Number of Days to Update: 86	Next Scheduled EDR Contact: 09/12/2022
	Data Release Frequency: Varies

NPDES: NPDES Permits Listing

A listing of NPDES permits, including stormwater.

Date of Government Version: 02/07/2022	Source: State Water Resources Control Board
Date Data Arrived at EDR: 02/08/2022	Telephone: 916-445-9379
Date Made Active in Reports: 05/05/2022	Last EDR Contact: 05/09/2022
Number of Days to Update: 86	Next Scheduled EDR Contact: 08/22/2022
	Data Release Frequency: Quarterly

PEST LIC: Pesticide Regulation Licenses Listing

A listing of licenses and certificates issued by the Department of Pesticide Regulation. The DPR issues licenses and/or certificates to: Persons and businesses that apply or sell pesticides; Pest control dealers and brokers; Persons who advise on agricultural pesticide applications.

Date of Government Version: 02/28/2022	Source: Department of Pesticide Regulation
Date Data Arrived at EDR: 02/28/2022	Telephone: 916-445-4038
Date Made Active in Reports: 05/25/2022	Last EDR Contact: 05/31/2022
Number of Days to Update: 86	Next Scheduled EDR Contact: 09/12/2022
	Data Release Frequency: Quarterly

PROC: Certified Processors Database

A listing of certified processors.

Date of Government Version: 03/07/2022	Source: Department of Conservation
Date Data Arrived at EDR: 03/08/2022	Telephone: 916-323-3836
Date Made Active in Reports: 06/02/2022	Last EDR Contact: 06/07/2022
Number of Days to Update: 86	Next Scheduled EDR Contact: 09/19/2022
	Data Release Frequency: Quarterly

NOTIFY 65: Proposition 65 Records

Listings of all Proposition 65 incidents reported to counties by the State Water Resources Control Board and the Regional Water Quality Control Board. This database is no longer updated by the reporting agency.

Date of Government Version: 03/11/2022	Source: State Water Resources Control Board
Date Data Arrived at EDR: 03/15/2022	Telephone: 916-445-3846
Date Made Active in Reports: 06/08/2022	Last EDR Contact: 06/09/2022
Number of Days to Update: 85	Next Scheduled EDR Contact: 09/26/2022
	Data Release Frequency: No Update Planned

GOVERNMENT RECORDS SEARCHED / DATA CURRENCY TRACKING

UIC: UIC Listing

A listing of wells identified as underground injection wells, in the California Oil and Gas Wells database.

Date of Government Version: 03/07/2022	Source: Department of Conservation
Date Data Arrived at EDR: 03/08/2022	Telephone: 916-445-2408
Date Made Active in Reports: 06/02/2022	Last EDR Contact: 06/07/2022
Number of Days to Update: 86	Next Scheduled EDR Contact: 09/19/2022
	Data Release Frequency: Varies

UIC GEO: Underground Injection Control Sites (GEOTRACKER)

Underground control injection sites

Date of Government Version: 05/23/2022	Source: State Water Resource Control Board
Date Data Arrived at EDR: 05/23/2022	Telephone: 866-480-1028
Date Made Active in Reports: 06/02/2022	Last EDR Contact: 05/23/2022
Number of Days to Update: 10	Next Scheduled EDR Contact: 09/19/2022
	Data Release Frequency: Varies

WASTEWATER PITS: Oil Wastewater Pits Listing

Water officials discovered that oil producers have been dumping chemical-laden wastewater into hundreds of unlined pits that are operating without proper permits. Inspections completed by the Central Valley Regional Water Quality Control Board revealed the existence of previously unidentified waste sites. The water boards review found that more than one-third of the region's active disposal pits are operating without permission.

Date of Government Version: 02/11/2021	Source: RWQCB, Central Valley Region
Date Data Arrived at EDR: 07/01/2021	Telephone: 559-445-5577
Date Made Active in Reports: 09/29/2021	Last EDR Contact: 04/08/2022
Number of Days to Update: 90	Next Scheduled EDR Contact: 07/18/2022
	Data Release Frequency: Varies

WDS: Waste Discharge System

Sites which have been issued waste discharge requirements.

Date of Government Version: 06/19/2007	Source: State Water Resources Control Board
Date Data Arrived at EDR: 06/20/2007	Telephone: 916-341-5227
Date Made Active in Reports: 06/29/2007	Last EDR Contact: 05/12/2022
Number of Days to Update: 9	Next Scheduled EDR Contact: 08/29/2022
	Data Release Frequency: No Update Planned

WIP: Well Investigation Program Case List

Well Investigation Program case in the San Gabriel and San Fernando Valley area.

Date of Government Version: 07/03/2009	Source: Los Angeles Water Quality Control Board
Date Data Arrived at EDR: 07/21/2009	Telephone: 213-576-6726
Date Made Active in Reports: 08/03/2009	Last EDR Contact: 06/14/2022
Number of Days to Update: 13	Next Scheduled EDR Contact: 10/03/2022
	Data Release Frequency: No Update Planned

MILITARY PRIV SITES: Military Privatized Sites (GEOTRACKER)

Military privatized sites

Date of Government Version: 05/23/2022	Source: State Water Resources Control Board
Date Data Arrived at EDR: 05/23/2022	Telephone: 866-480-1028
Date Made Active in Reports: 06/02/2022	Last EDR Contact: 05/23/2022
Number of Days to Update: 10	Next Scheduled EDR Contact: 09/19/2022
	Data Release Frequency: Varies

PROJECT: Project Sites (GEOTRACKER)

Projects sites

GOVERNMENT RECORDS SEARCHED / DATA CURRENCY TRACKING

Date of Government Version: 05/23/2022
Date Data Arrived at EDR: 05/23/2022
Date Made Active in Reports: 06/02/2022
Number of Days to Update: 10

Source: State Water Resources Control Board
Telephone: 866-480-1028
Last EDR Contact: 05/23/2022
Next Scheduled EDR Contact: 09/19/2022
Data Release Frequency: Varies

WDR: Waste Discharge Requirements Listing

In general, the Waste Discharge Requirements (WDRs) Program (sometimes also referred to as the "Non Chapter 15 (Non 15) Program") regulates point discharges that are exempt pursuant to Subsection 20090 of Title 27 and not subject to the Federal Water Pollution Control Act. Exemptions from Title 27 may be granted for nine categories of discharges (e.g., sewage, wastewater, etc.) that meet, and continue to meet, the preconditions listed for each specific exemption. The scope of the WDRs Program also includes the discharge of wastes classified as inert, pursuant to section 20230 of Title 27.

Date of Government Version: 03/07/2022
Date Data Arrived at EDR: 03/08/2022
Date Made Active in Reports: 06/03/2022
Number of Days to Update: 87

Source: State Water Resources Control Board
Telephone: 916-341-5810
Last EDR Contact: 06/07/2022
Next Scheduled EDR Contact: 09/19/2022
Data Release Frequency: Quarterly

CIWQS: California Integrated Water Quality System

The California Integrated Water Quality System (CIWQS) is a computer system used by the State and Regional Water Quality Control Boards to track information about places of environmental interest, manage permits and other orders, track inspections, and manage violations and enforcement activities.

Date of Government Version: 02/28/2022
Date Data Arrived at EDR: 02/28/2022
Date Made Active in Reports: 05/25/2022
Number of Days to Update: 86

Source: State Water Resources Control Board
Telephone: 866-794-4977
Last EDR Contact: 05/31/2022
Next Scheduled EDR Contact: 09/12/2022
Data Release Frequency: Varies

CERS: CalEPA Regulated Site Portal Data

The CalEPA Regulated Site Portal database combines data about environmentally regulated sites and facilities in California into a single database. It combines data from a variety of state and federal databases, and provides an overview of regulated activities across the spectrum of environmental programs for any given location in California. These activities include hazardous materials and waste, state and federal cleanups, impacted ground and surface waters, and toxic materials

Date of Government Version: 01/18/2022
Date Data Arrived at EDR: 01/19/2022
Date Made Active in Reports: 04/08/2022
Number of Days to Update: 79

Source: California Environmental Protection Agency
Telephone: 916-323-2514
Last EDR Contact: 04/19/2022
Next Scheduled EDR Contact: 08/01/2022
Data Release Frequency: Varies

NON-CASE INFO: Non-Case Information Sites (GEOTRACKER)

Non-Case Information sites

Date of Government Version: 05/23/2022
Date Data Arrived at EDR: 05/23/2022
Date Made Active in Reports: 06/02/2022
Number of Days to Update: 10

Source: State Water Resources Control Board
Telephone: 866-480-1028
Last EDR Contact: 05/23/2022
Next Scheduled EDR Contact: 09/19/2022
Data Release Frequency: Varies

OTHER OIL GAS: Other Oil & Gas Projects Sites (GEOTRACKER)

Other Oil & Gas Projects sites

Date of Government Version: 05/23/2022
Date Data Arrived at EDR: 05/23/2022
Date Made Active in Reports: 06/02/2022
Number of Days to Update: 10

Source: State Water Resources Control Board
Telephone: 866-480-1028
Last EDR Contact: 05/23/2022
Next Scheduled EDR Contact: 09/19/2022
Data Release Frequency: Varies

GOVERNMENT RECORDS SEARCHED / DATA CURRENCY TRACKING

PROD WATER PONDS: Produced Water Ponds Sites (GEOTRACKER)

Produced water ponds sites

Date of Government Version: 05/23/2022
Date Data Arrived at EDR: 05/23/2022
Date Made Active in Reports: 06/02/2022
Number of Days to Update: 10

Source: State Water Resources Control Board
Telephone: 866-480-1028
Last EDR Contact: 05/23/2022
Next Scheduled EDR Contact: 09/19/2022
Data Release Frequency: Varies

SAMPLING POINT: Sampling Point ? Public Sites (GEOTRACKER)

Sampling point - public sites

Date of Government Version: 05/23/2022
Date Data Arrived at EDR: 05/23/2022
Date Made Active in Reports: 06/02/2022
Number of Days to Update: 10

Source: State Water Resources Control Board
Telephone: 866-480-1028
Last EDR Contact: 05/23/2022
Next Scheduled EDR Contact: 09/19/2022
Data Release Frequency: Varies

WELL STIM PROJ: Well Stimulation Project (GEOTRACKER)

Includes areas of groundwater monitoring plans, a depiction of the monitoring network, and the facilities, boundaries, and subsurface characteristics of the oilfield and the features (oil and gas wells, produced water ponds, UIC wells, water supply wells, etc?) being monitored

Date of Government Version: 05/23/2022
Date Data Arrived at EDR: 05/23/2022
Date Made Active in Reports: 06/02/2022
Number of Days to Update: 10

Source: State Water Resources Control Board
Telephone: 866-480-1028
Last EDR Contact: 05/23/2022
Next Scheduled EDR Contact: 09/19/2022
Data Release Frequency: Varies

PCS ENF: Enforcement data

No description is available for this data

Date of Government Version: 12/31/2014
Date Data Arrived at EDR: 02/05/2015
Date Made Active in Reports: 03/06/2015
Number of Days to Update: 29

Source: EPA
Telephone: 202-564-2497
Last EDR Contact: 03/31/2022
Next Scheduled EDR Contact: 07/18/2022
Data Release Frequency: Varies

PCS: Permit Compliance System

PCS is a computerized management information system that contains data on National Pollutant Discharge Elimination System (NPDES) permit holding facilities. PCS tracks the permit, compliance, and enforcement status of NPDES facilities.

Date of Government Version: 07/14/2011
Date Data Arrived at EDR: 08/05/2011
Date Made Active in Reports: 09/29/2011
Number of Days to Update: 55

Source: EPA, Office of Water
Telephone: 202-564-2496
Last EDR Contact: 03/31/2022
Next Scheduled EDR Contact: 07/18/2022
Data Release Frequency: Semi-Annually

PCS INACTIVE: Listing of Inactive PCS Permits

An inactive permit is a facility that has shut down or is no longer discharging.

Date of Government Version: 11/05/2014
Date Data Arrived at EDR: 01/06/2015
Date Made Active in Reports: 05/06/2015
Number of Days to Update: 120

Source: EPA
Telephone: 202-564-2496
Last EDR Contact: 03/31/2022
Next Scheduled EDR Contact: 07/18/2022
Data Release Frequency: Semi-Annually

MINES MRDS: Mineral Resources Data System

Mineral Resources Data System

GOVERNMENT RECORDS SEARCHED / DATA CURRENCY TRACKING

Date of Government Version: 04/06/2018
Date Data Arrived at EDR: 10/21/2019
Date Made Active in Reports: 10/24/2019
Number of Days to Update: 3

Source: USGS
Telephone: 703-648-6533
Last EDR Contact: 05/27/2022
Next Scheduled EDR Contact: 09/05/2022
Data Release Frequency: Varies

HWTS: Hazardous Waste Tracking System

DTSC maintains the Hazardous Waste Tracking System that stores ID number information since the early 1980s and manifest data since 1993. The system collects both manifest copies from the generator and destination facility.

Date of Government Version: 04/05/2022
Date Data Arrived at EDR: 04/05/2022
Date Made Active in Reports: 04/26/2022
Number of Days to Update: 21

Source: Department of Toxic Substances Control
Telephone: 916-324-2444
Last EDR Contact: 04/05/2022
Next Scheduled EDR Contact: 07/18/2022
Data Release Frequency: Varies

EDR HIGH RISK HISTORICAL RECORDS

EDR Exclusive Records

EDR MGP: EDR Proprietary Manufactured Gas Plants

The EDR Proprietary Manufactured Gas Plant Database includes records of coal gas plants (manufactured gas plants) compiled by EDR's researchers. Manufactured gas sites were used in the United States from the 1800's to 1950's to produce a gas that could be distributed and used as fuel. These plants used whale oil, rosin, coal, or a mixture of coal, oil, and water that also produced a significant amount of waste. Many of the byproducts of the gas production, such as coal tar (oily waste containing volatile and non-volatile chemicals), sludges, oils and other compounds are potentially hazardous to human health and the environment. The byproduct from this process was frequently disposed of directly at the plant site and can remain or spread slowly, serving as a continuous source of soil and groundwater contamination.

Date of Government Version: N/A
Date Data Arrived at EDR: N/A
Date Made Active in Reports: N/A
Number of Days to Update: N/A

Source: EDR, Inc.
Telephone: N/A
Last EDR Contact: N/A
Next Scheduled EDR Contact: N/A
Data Release Frequency: No Update Planned

EDR Hist Auto: EDR Exclusive Historical Auto Stations

EDR has searched selected national collections of business directories and has collected listings of potential gas station/filling station/service station sites that were available to EDR researchers. EDR's review was limited to those categories of sources that might, in EDR's opinion, include gas station/filling station/service station establishments. The categories reviewed included, but were not limited to gas, gas station, gasoline station, filling station, auto, automobile repair, auto service station, service station, etc. This database falls within a category of information EDR classifies as "High Risk Historical Records", or HRHR. EDR's HRHR effort presents unique and sometimes proprietary data about past sites and operations that typically create environmental concerns, but may not show up in current government records searches.

Date of Government Version: N/A
Date Data Arrived at EDR: N/A
Date Made Active in Reports: N/A
Number of Days to Update: N/A

Source: EDR, Inc.
Telephone: N/A
Last EDR Contact: N/A
Next Scheduled EDR Contact: N/A
Data Release Frequency: Varies

EDR Hist Cleaner: EDR Exclusive Historical Cleaners

EDR has searched selected national collections of business directories and has collected listings of potential dry cleaner sites that were available to EDR researchers. EDR's review was limited to those categories of sources that might, in EDR's opinion, include dry cleaning establishments. The categories reviewed included, but were not limited to dry cleaners, cleaners, laundry, laundromat, cleaning/laundry, wash & dry etc. This database falls within a category of information EDR classifies as "High Risk Historical Records", or HRHR. EDR's HRHR effort presents unique and sometimes proprietary data about past sites and operations that typically create environmental concerns, but may not show up in current government records searches.

GOVERNMENT RECORDS SEARCHED / DATA CURRENCY TRACKING

Date of Government Version: N/A
Date Data Arrived at EDR: N/A
Date Made Active in Reports: N/A
Number of Days to Update: N/A

Source: EDR, Inc.
Telephone: N/A
Last EDR Contact: N/A
Next Scheduled EDR Contact: N/A
Data Release Frequency: Varies

EDR RECOVERED GOVERNMENT ARCHIVES

Exclusive Recovered Govt. Archives

RGA LF: Recovered Government Archive Solid Waste Facilities List

The EDR Recovered Government Archive Landfill database provides a list of landfills derived from historical databases and includes many records that no longer appear in current government lists. Compiled from Records formerly available from the Department of Resources Recycling and Recovery in California.

Date of Government Version: N/A
Date Data Arrived at EDR: 07/01/2013
Date Made Active in Reports: 01/13/2014
Number of Days to Update: 196

Source: Department of Resources Recycling and Recovery
Telephone: N/A
Last EDR Contact: 06/01/2012
Next Scheduled EDR Contact: N/A
Data Release Frequency: Varies

RGA LUST: Recovered Government Archive Leaking Underground Storage Tank

The EDR Recovered Government Archive Leaking Underground Storage Tank database provides a list of LUST incidents derived from historical databases and includes many records that no longer appear in current government lists. Compiled from Records formerly available from the State Water Resources Control Board in California.

Date of Government Version: N/A
Date Data Arrived at EDR: 07/01/2013
Date Made Active in Reports: 12/30/2013
Number of Days to Update: 182

Source: State Water Resources Control Board
Telephone: N/A
Last EDR Contact: 06/01/2012
Next Scheduled EDR Contact: N/A
Data Release Frequency: Varies

COUNTY RECORDS

ALAMEDA COUNTY:

CS ALAMEDA: Contaminated Sites

A listing of contaminated sites overseen by the Toxic Release Program (oil and groundwater contamination from chemical releases and spills) and the Leaking Underground Storage Tank Program (soil and ground water contamination from leaking petroleum USTs).

Date of Government Version: 01/09/2019
Date Data Arrived at EDR: 01/11/2019
Date Made Active in Reports: 03/05/2019
Number of Days to Update: 53

Source: Alameda County Environmental Health Services
Telephone: 510-567-6700
Last EDR Contact: 03/31/2022
Next Scheduled EDR Contact: 07/18/2022
Data Release Frequency: Semi-Annually

UST ALAMEDA: Underground Tanks

Underground storage tank sites located in Alameda county.

Date of Government Version: 12/28/2021
Date Data Arrived at EDR: 12/28/2021
Date Made Active in Reports: 03/18/2022
Number of Days to Update: 80

Source: Alameda County Environmental Health Services
Telephone: 510-567-6700
Last EDR Contact: 04/28/2022
Next Scheduled EDR Contact: 07/18/2022
Data Release Frequency: Semi-Annually

AMADOR COUNTY:

GOVERNMENT RECORDS SEARCHED / DATA CURRENCY TRACKING

CUPA AMADOR: CUPA Facility List Cupa Facility List

Date of Government Version: 02/04/2022
Date Data Arrived at EDR: 02/04/2022
Date Made Active in Reports: 05/02/2022
Number of Days to Update: 87

Source: Amador County Environmental Health
Telephone: 209-223-6439
Last EDR Contact: 05/12/2022
Next Scheduled EDR Contact: 08/15/2022
Data Release Frequency: Varies

BUTTE COUNTY:

CUPA BUTTE: CUPA Facility Listing Cupa facility list.

Date of Government Version: 04/21/2017
Date Data Arrived at EDR: 04/25/2017
Date Made Active in Reports: 08/09/2017
Number of Days to Update: 106

Source: Public Health Department
Telephone: 530-538-7149
Last EDR Contact: 03/31/2022
Next Scheduled EDR Contact: 07/18/2022
Data Release Frequency: No Update Planned

CALVERAS COUNTY:

CUPA CALVERAS: CUPA Facility Listing Cupa Facility Listing

Date of Government Version: 03/17/2022
Date Data Arrived at EDR: 03/18/2022
Date Made Active in Reports: 06/08/2022
Number of Days to Update: 82

Source: Calveras County Environmental Health
Telephone: 209-754-6399
Last EDR Contact: 06/14/2022
Next Scheduled EDR Contact: 10/03/2022
Data Release Frequency: Quarterly

COLUSA COUNTY:

CUPA COLUSA: CUPA Facility List Cupa facility list.

Date of Government Version: 04/06/2020
Date Data Arrived at EDR: 04/23/2020
Date Made Active in Reports: 07/10/2020
Number of Days to Update: 78

Source: Health & Human Services
Telephone: 530-458-0396
Last EDR Contact: 04/28/2022
Next Scheduled EDR Contact: 08/15/2022
Data Release Frequency: Semi-Annually

CONTRA COSTA COUNTY:

SL CONTRA COSTA: Site List

List includes sites from the underground tank, hazardous waste generator and business plan/2185 programs.

Date of Government Version: 01/24/2022
Date Data Arrived at EDR: 01/25/2022
Date Made Active in Reports: 04/14/2022
Number of Days to Update: 79

Source: Contra Costa Health Services Department
Telephone: 925-646-2286
Last EDR Contact: 04/21/2022
Next Scheduled EDR Contact: 08/08/2022
Data Release Frequency: Semi-Annually

DEL NORTE COUNTY:

GOVERNMENT RECORDS SEARCHED / DATA CURRENCY TRACKING

CUPA DEL NORTE: CUPA Facility List Cupa Facility list

Date of Government Version: 01/10/2022
Date Data Arrived at EDR: 01/26/2022
Date Made Active in Reports: 04/14/2022
Number of Days to Update: 78

Source: Del Norte County Environmental Health Division
Telephone: 707-465-0426
Last EDR Contact: 05/04/2022
Next Scheduled EDR Contact: 08/08/2022
Data Release Frequency: Varies

EL DORADO COUNTY:

CUPA EL DORADO: CUPA Facility List CUPA facility list.

Date of Government Version: 02/16/2022
Date Data Arrived at EDR: 02/17/2022
Date Made Active in Reports: 05/10/2022
Number of Days to Update: 82

Source: El Dorado County Environmental Management Department
Telephone: 530-621-6623
Last EDR Contact: 06/14/2022
Next Scheduled EDR Contact: 08/08/2022
Data Release Frequency: Varies

FRESNO COUNTY:

CUPA FRESNO: CUPA Resources List

Certified Unified Program Agency. CUPA's are responsible for implementing a unified hazardous materials and hazardous waste management regulatory program. The agency provides oversight of businesses that deal with hazardous materials, operate underground storage tanks or aboveground storage tanks.

Date of Government Version: 06/28/2021
Date Data Arrived at EDR: 12/21/2021
Date Made Active in Reports: 03/03/2022
Number of Days to Update: 72

Source: Dept. of Community Health
Telephone: 559-445-3271
Last EDR Contact: 03/31/2022
Next Scheduled EDR Contact: 07/11/2022
Data Release Frequency: Semi-Annually

GLENN COUNTY:

CUPA GLENN: CUPA Facility List Cupa facility list

Date of Government Version: 01/22/2018
Date Data Arrived at EDR: 01/24/2018
Date Made Active in Reports: 03/14/2018
Number of Days to Update: 49

Source: Glenn County Air Pollution Control District
Telephone: 830-934-6500
Last EDR Contact: 04/14/2022
Next Scheduled EDR Contact: 08/01/2022
Data Release Frequency: No Update Planned

HUMBOLDT COUNTY:

CUPA HUMBOLDT: CUPA Facility List CUPA facility list.

Date of Government Version: 08/12/2021
Date Data Arrived at EDR: 08/12/2021
Date Made Active in Reports: 11/08/2021
Number of Days to Update: 88

Source: Humboldt County Environmental Health
Telephone: N/A
Last EDR Contact: 05/12/2022
Next Scheduled EDR Contact: 08/29/2022
Data Release Frequency: Semi-Annually

IMPERIAL COUNTY:

GOVERNMENT RECORDS SEARCHED / DATA CURRENCY TRACKING

CUPA IMPERIAL: CUPA Facility List Cupa facility list.

Date of Government Version: 01/13/2022
Date Data Arrived at EDR: 01/14/2022
Date Made Active in Reports: 04/06/2022
Number of Days to Update: 82

Source: San Diego Border Field Office
Telephone: 760-339-2777
Last EDR Contact: 04/18/2022
Next Scheduled EDR Contact: 08/01/2022
Data Release Frequency: Varies

INYO COUNTY:

CUPA INYO: CUPA Facility List Cupa facility list.

Date of Government Version: 04/02/2018
Date Data Arrived at EDR: 04/03/2018
Date Made Active in Reports: 06/14/2018
Number of Days to Update: 72

Source: Inyo County Environmental Health Services
Telephone: 760-878-0238
Last EDR Contact: 05/12/2022
Next Scheduled EDR Contact: 08/29/2022
Data Release Frequency: Varies

KERN COUNTY:

CUPA KERN: CUPA Facility List

A listing of sites included in the Kern County Hazardous Material Business Plan.

Date of Government Version: 02/10/2022
Date Data Arrived at EDR: 02/11/2022
Date Made Active in Reports: 05/04/2022
Number of Days to Update: 82

Source: Kern County Public Health
Telephone: 661-321-3000
Last EDR Contact: 04/28/2022
Next Scheduled EDR Contact: 08/15/2022
Data Release Frequency: Varies

UST KERN: Underground Storage Tank Sites & Tank Listing Kern County Sites and Tanks Listing.

Date of Government Version: 02/10/2022
Date Data Arrived at EDR: 02/11/2022
Date Made Active in Reports: 05/04/2022
Number of Days to Update: 82

Source: Kern County Environment Health Services Department
Telephone: 661-862-8700
Last EDR Contact: 04/28/2022
Next Scheduled EDR Contact: 08/15/2022
Data Release Frequency: Quarterly

KINGS COUNTY:

CUPA KINGS: CUPA Facility List

A listing of sites included in the county's Certified Unified Program Agency database. California's Secretary for Environmental Protection established the unified hazardous materials and hazardous waste regulatory program as required by chapter 6.11 of the California Health and Safety Code. The Unified Program consolidates the administration, permits, inspections, and enforcement activities.

Date of Government Version: 12/03/2020
Date Data Arrived at EDR: 01/26/2021
Date Made Active in Reports: 04/14/2021
Number of Days to Update: 78

Source: Kings County Department of Public Health
Telephone: 559-584-1411
Last EDR Contact: 05/25/2022
Next Scheduled EDR Contact: 08/29/2022
Data Release Frequency: Varies

LAKE COUNTY:

GOVERNMENT RECORDS SEARCHED / DATA CURRENCY TRACKING

CUPA LAKE: CUPA Facility List Cupa facility list

Date of Government Version: 02/10/2022
Date Data Arrived at EDR: 02/11/2022
Date Made Active in Reports: 05/04/2022
Number of Days to Update: 82

Source: Lake County Environmental Health
Telephone: 707-263-1164
Last EDR Contact: 04/11/2022
Next Scheduled EDR Contact: 07/25/2022
Data Release Frequency: Varies

LASSEN COUNTY:

CUPA LASSEN: CUPA Facility List Cupa facility list

Date of Government Version: 07/31/2020
Date Data Arrived at EDR: 08/21/2020
Date Made Active in Reports: 11/09/2020
Number of Days to Update: 80

Source: Lassen County Environmental Health
Telephone: 530-251-8528
Last EDR Contact: 04/14/2022
Next Scheduled EDR Contact: 08/01/2022
Data Release Frequency: Varies

LOS ANGELES COUNTY:

AOCONCERN: Key Areas of Concerns in Los Angeles County

San Gabriel Valley areas where VOC contamination is at or above the MCL as designated by region 9 EPA office. Date of Government Version: 3/30/2009 Exide Site area is a cleanup plan of lead-impacted soil surrounding the former Exide Facility as designated by the DTSC. Date of Government Version: 7/17/2017

Date of Government Version: 03/30/2009
Date Data Arrived at EDR: 03/31/2009
Date Made Active in Reports: 10/23/2009
Number of Days to Update: 206

Source: N/A
Telephone: N/A
Last EDR Contact: 06/09/2022
Next Scheduled EDR Contact: 09/26/2022
Data Release Frequency: No Update Planned

HMS LOS ANGELES: HMS: Street Number List

Industrial Waste and Underground Storage Tank Sites.

Date of Government Version: 04/04/2022
Date Data Arrived at EDR: 04/05/2022
Date Made Active in Reports: 04/13/2022
Number of Days to Update: 8

Source: Department of Public Works
Telephone: 626-458-3517
Last EDR Contact: 04/04/2022
Next Scheduled EDR Contact: 07/18/2022
Data Release Frequency: Semi-Annually

LF LOS ANGELES: List of Solid Waste Facilities Solid Waste Facilities in Los Angeles County.

Date of Government Version: 01/10/2022
Date Data Arrived at EDR: 01/11/2022
Date Made Active in Reports: 04/04/2022
Number of Days to Update: 83

Source: La County Department of Public Works
Telephone: 818-458-5185
Last EDR Contact: 04/12/2022
Next Scheduled EDR Contact: 07/25/2022
Data Release Frequency: Varies

LF LOS ANGELES CITY: City of Los Angeles Landfills

Landfills owned and maintained by the City of Los Angeles.

Date of Government Version: 01/01/2022
Date Data Arrived at EDR: 01/21/2022
Date Made Active in Reports: 04/11/2022
Number of Days to Update: 80

Source: Engineering & Construction Division
Telephone: 213-473-7869
Last EDR Contact: 04/08/2022
Next Scheduled EDR Contact: 07/25/2022
Data Release Frequency: Varies

GOVERNMENT RECORDS SEARCHED / DATA CURRENCY TRACKING

LOS ANGELES AST: Active & Inactive AST Inventory

A listing of active & inactive above ground petroleum storage tank site locations, located in the City of Los Angeles.

Date of Government Version: 06/01/2019	Source: Los Angeles Fire Department
Date Data Arrived at EDR: 06/25/2019	Telephone: 213-978-3800
Date Made Active in Reports: 08/22/2019	Last EDR Contact: 06/14/2022
Number of Days to Update: 58	Next Scheduled EDR Contact: 10/03/2022
	Data Release Frequency: Varies

LOS ANGELES CO LF METHANE: Methane Producing Landfills

This data was created on April 30, 2012 to represent known disposal sites in Los Angeles County that may produce and emanate methane gas. The shapefile contains disposal sites within Los Angeles County that once accepted degradable refuse material. Information used to create this data was extracted from a landfill survey performed by County Engineers (Major Waste System Map, 1973) as well as historical records from CalRecycle, Regional Water Quality Control Board, and Los Angeles County Department of Public Health

Date of Government Version: 01/10/2022	Source: Los Angeles County Department of Public Works
Date Data Arrived at EDR: 01/12/2022	Telephone: 626-458-6973
Date Made Active in Reports: 04/04/2022	Last EDR Contact: 04/13/2022
Number of Days to Update: 82	Next Scheduled EDR Contact: 07/25/2022
	Data Release Frequency: No Update Planned

LOS ANGELES HM: Active & Inactive Hazardous Materials Inventory

A listing of active & inactive hazardous materials facility locations, located in the City of Los Angeles.

Date of Government Version: 01/13/2022	Source: Los Angeles Fire Department
Date Data Arrived at EDR: 03/21/2022	Telephone: 213-978-3800
Date Made Active in Reports: 06/15/2022	Last EDR Contact: 03/21/2022
Number of Days to Update: 86	Next Scheduled EDR Contact: 07/04/2022
	Data Release Frequency: Varies

LOS ANGELES UST: Active & Inactive UST Inventory

A listing of active & inactive underground storage tank site locations and underground storage tank historical sites, located in the City of Los Angeles.

Date of Government Version: 01/13/2022	Source: Los Angeles Fire Department
Date Data Arrived at EDR: 03/21/2022	Telephone: 213-978-3800
Date Made Active in Reports: 06/15/2022	Last EDR Contact: 03/21/2022
Number of Days to Update: 86	Next Scheduled EDR Contact: 07/04/2022
	Data Release Frequency: Varies

SITE MIT LOS ANGELES: Site Mitigation List

Industrial sites that have had some sort of spill or complaint.

Date of Government Version: 05/26/2021	Source: Community Health Services
Date Data Arrived at EDR: 07/09/2021	Telephone: 323-890-7806
Date Made Active in Reports: 09/29/2021	Last EDR Contact: 04/14/2022
Number of Days to Update: 82	Next Scheduled EDR Contact: 07/25/2022
	Data Release Frequency: Annually

UST EL SEGUNDO: City of El Segundo Underground Storage Tank

Underground storage tank sites located in El Segundo city.

Date of Government Version: 01/21/2017	Source: City of El Segundo Fire Department
Date Data Arrived at EDR: 04/19/2017	Telephone: 310-524-2236
Date Made Active in Reports: 05/10/2017	Last EDR Contact: 04/08/2022
Number of Days to Update: 21	Next Scheduled EDR Contact: 07/25/2022
	Data Release Frequency: No Update Planned

GOVERNMENT RECORDS SEARCHED / DATA CURRENCY TRACKING

UST LONG BEACH: City of Long Beach Underground Storage Tank
Underground storage tank sites located in the city of Long Beach.

Date of Government Version: 04/22/2019	Source: City of Long Beach Fire Department
Date Data Arrived at EDR: 04/23/2019	Telephone: 562-570-2563
Date Made Active in Reports: 06/27/2019	Last EDR Contact: 04/14/2022
Number of Days to Update: 65	Next Scheduled EDR Contact: 08/01/2022
	Data Release Frequency: Varies

UST TORRANCE: City of Torrance Underground Storage Tank
Underground storage tank sites located in the city of Torrance.

Date of Government Version: 02/02/2021	Source: City of Torrance Fire Department
Date Data Arrived at EDR: 04/28/2021	Telephone: 310-618-2973
Date Made Active in Reports: 07/13/2021	Last EDR Contact: 04/18/2022
Number of Days to Update: 76	Next Scheduled EDR Contact: 08/01/2022
	Data Release Frequency: Semi-Annually

MADERA COUNTY:

CUPA MADERA: CUPA Facility List

A listing of sites included in the county's Certified Unified Program Agency database. California's Secretary for Environmental Protection established the unified hazardous materials and hazardous waste regulatory program as required by chapter 6.11 of the California Health and Safety Code. The Unified Program consolidates the administration, permits, inspections, and enforcement activities.

Date of Government Version: 08/10/2020	Source: Madera County Environmental Health
Date Data Arrived at EDR: 08/12/2020	Telephone: 559-675-7823
Date Made Active in Reports: 10/23/2020	Last EDR Contact: 05/12/2022
Number of Days to Update: 72	Next Scheduled EDR Contact: 08/29/2022
	Data Release Frequency: Varies

MARIN COUNTY:

UST MARIN: Underground Storage Tank Sites
Currently permitted USTs in Marin County.

Date of Government Version: 09/26/2018	Source: Public Works Department Waste Management
Date Data Arrived at EDR: 10/04/2018	Telephone: 415-473-6647
Date Made Active in Reports: 11/02/2018	Last EDR Contact: 03/23/2022
Number of Days to Update: 29	Next Scheduled EDR Contact: 07/11/2022
	Data Release Frequency: Semi-Annually

MENDOCINO COUNTY:

UST MENDOCINO: Mendocino County UST Database
A listing of underground storage tank locations in Mendocino County.

Date of Government Version: 09/22/2021	Source: Department of Public Health
Date Data Arrived at EDR: 11/18/2021	Telephone: 707-463-4466
Date Made Active in Reports: 11/22/2021	Last EDR Contact: 05/19/2022
Number of Days to Update: 4	Next Scheduled EDR Contact: 09/05/2022
	Data Release Frequency: Annually

MERCED COUNTY:

GOVERNMENT RECORDS SEARCHED / DATA CURRENCY TRACKING

CUPA MERCED: CUPA Facility List CUPA facility list.

Date of Government Version: 02/15/2022
Date Data Arrived at EDR: 02/17/2022
Date Made Active in Reports: 05/11/2022
Number of Days to Update: 83

Source: Merced County Environmental Health
Telephone: 209-381-1094
Last EDR Contact: 06/09/2022
Next Scheduled EDR Contact: 08/29/2022
Data Release Frequency: Varies

MONO COUNTY:

CUPA MONO: CUPA Facility List CUPA Facility List

Date of Government Version: 02/22/2021
Date Data Arrived at EDR: 03/02/2021
Date Made Active in Reports: 05/19/2021
Number of Days to Update: 78

Source: Mono County Health Department
Telephone: 760-932-5580
Last EDR Contact: 05/19/2022
Next Scheduled EDR Contact: 09/05/2022
Data Release Frequency: Varies

MONTEREY COUNTY:

CUPA MONTEREY: CUPA Facility Listing CUPA Program listing from the Environmental Health Division.

Date of Government Version: 10/04/2021
Date Data Arrived at EDR: 10/06/2021
Date Made Active in Reports: 12/29/2021
Number of Days to Update: 84

Source: Monterey County Health Department
Telephone: 831-796-1297
Last EDR Contact: 04/04/2022
Next Scheduled EDR Contact: 07/11/2022
Data Release Frequency: Varies

NAPA COUNTY:

LUST NAPA: Sites With Reported Contamination A listing of leaking underground storage tank sites located in Napa county.

Date of Government Version: 01/09/2017
Date Data Arrived at EDR: 01/11/2017
Date Made Active in Reports: 03/02/2017
Number of Days to Update: 50

Source: Napa County Department of Environmental Management
Telephone: 707-253-4269
Last EDR Contact: 05/19/2022
Next Scheduled EDR Contact: 09/05/2022
Data Release Frequency: No Update Planned

UST NAPA: Closed and Operating Underground Storage Tank Sites Underground storage tank sites located in Napa county.

Date of Government Version: 09/05/2019
Date Data Arrived at EDR: 09/09/2019
Date Made Active in Reports: 10/31/2019
Number of Days to Update: 52

Source: Napa County Department of Environmental Management
Telephone: 707-253-4269
Last EDR Contact: 05/19/2022
Next Scheduled EDR Contact: 09/05/2022
Data Release Frequency: No Update Planned

NEVADA COUNTY:

CUPA NEVADA: CUPA Facility List CUPA facility list.

GOVERNMENT RECORDS SEARCHED / DATA CURRENCY TRACKING

Date of Government Version: 01/25/2022
Date Data Arrived at EDR: 01/26/2022
Date Made Active in Reports: 04/14/2022
Number of Days to Update: 78

Source: Community Development Agency
Telephone: 530-265-1467
Last EDR Contact: 04/21/2022
Next Scheduled EDR Contact: 08/08/2022
Data Release Frequency: Varies

ORANGE COUNTY:

IND_SITE ORANGE: List of Industrial Site Cleanups
Petroleum and non-petroleum spills.

Date of Government Version: 01/14/2022
Date Data Arrived at EDR: 02/03/2022
Date Made Active in Reports: 04/14/2022
Number of Days to Update: 70

Source: Health Care Agency
Telephone: 714-834-3446
Last EDR Contact: 05/02/2022
Next Scheduled EDR Contact: 08/15/2022
Data Release Frequency: Annually

LUST ORANGE: List of Underground Storage Tank Cleanups
Orange County Underground Storage Tank Cleanups (LUST).

Date of Government Version: 01/14/2022
Date Data Arrived at EDR: 02/04/2022
Date Made Active in Reports: 05/02/2022
Number of Days to Update: 87

Source: Health Care Agency
Telephone: 714-834-3446
Last EDR Contact: 05/02/2022
Next Scheduled EDR Contact: 08/15/2022
Data Release Frequency: Quarterly

UST ORANGE: List of Underground Storage Tank Facilities
Orange County Underground Storage Tank Facilities (UST).

Date of Government Version: 01/14/2022
Date Data Arrived at EDR: 02/01/2022
Date Made Active in Reports: 04/18/2022
Number of Days to Update: 76

Source: Health Care Agency
Telephone: 714-834-3446
Last EDR Contact: 05/03/2022
Next Scheduled EDR Contact: 08/15/2022
Data Release Frequency: Quarterly

PLACER COUNTY:

MS PLACER: Master List of Facilities
List includes aboveground tanks, underground tanks and cleanup sites.

Date of Government Version: 05/25/2022
Date Data Arrived at EDR: 05/26/2022
Date Made Active in Reports: 06/01/2022
Number of Days to Update: 6

Source: Placer County Health and Human Services
Telephone: 530-745-2363
Last EDR Contact: 05/25/2022
Next Scheduled EDR Contact: 09/12/2022
Data Release Frequency: Semi-Annually

PLUMAS COUNTY:

CUPA PLUMAS: CUPA Facility List
Plumas County CUPA Program facilities.

Date of Government Version: 03/31/2019
Date Data Arrived at EDR: 04/23/2019
Date Made Active in Reports: 06/26/2019
Number of Days to Update: 64

Source: Plumas County Environmental Health
Telephone: 530-283-6355
Last EDR Contact: 04/14/2022
Next Scheduled EDR Contact: 08/01/2022
Data Release Frequency: Varies

RIVERSIDE COUNTY:

GOVERNMENT RECORDS SEARCHED / DATA CURRENCY TRACKING

LUST RIVERSIDE: Listing of Underground Tank Cleanup Sites

Riverside County Underground Storage Tank Cleanup Sites (LUST).

Date of Government Version: 03/31/2022
Date Data Arrived at EDR: 03/31/2022
Date Made Active in Reports: 04/08/2022
Number of Days to Update: 8

Source: Department of Environmental Health
Telephone: 951-358-5055
Last EDR Contact: 06/09/2022
Next Scheduled EDR Contact: 09/26/2022
Data Release Frequency: Quarterly

UST RIVERSIDE: Underground Storage Tank Tank List

Underground storage tank sites located in Riverside county.

Date of Government Version: 03/31/2022
Date Data Arrived at EDR: 03/31/2022
Date Made Active in Reports: 04/08/2022
Number of Days to Update: 8

Source: Department of Environmental Health
Telephone: 951-358-5055
Last EDR Contact: 06/09/2022
Next Scheduled EDR Contact: 09/26/2022
Data Release Frequency: Quarterly

SACRAMENTO COUNTY:

CS SACRAMENTO: Toxic Site Clean-Up List

List of sites where unauthorized releases of potentially hazardous materials have occurred.

Date of Government Version: 06/18/2021
Date Data Arrived at EDR: 09/28/2021
Date Made Active in Reports: 12/14/2021
Number of Days to Update: 77

Source: Sacramento County Environmental Management
Telephone: 916-875-8406
Last EDR Contact: 03/31/2022
Next Scheduled EDR Contact: 07/11/2022
Data Release Frequency: Quarterly

ML SACRAMENTO: Master Hazardous Materials Facility List

Any business that has hazardous materials on site - hazardous material storage sites, underground storage tanks, waste generators.

Date of Government Version: 08/02/2021
Date Data Arrived at EDR: 08/04/2021
Date Made Active in Reports: 11/02/2021
Number of Days to Update: 90

Source: Sacramento County Environmental Management
Telephone: 916-875-8406
Last EDR Contact: 03/31/2022
Next Scheduled EDR Contact: 07/11/2022
Data Release Frequency: Quarterly

SAN BENITO COUNTY:

CUPA SAN BENITO: CUPA Facility List

Cupa facility list

Date of Government Version: 04/29/2022
Date Data Arrived at EDR: 04/29/2022
Date Made Active in Reports: 05/05/2022
Number of Days to Update: 6

Source: San Benito County Environmental Health
Telephone: N/A
Last EDR Contact: 04/28/2022
Next Scheduled EDR Contact: 08/15/2022
Data Release Frequency: Varies

SAN BERNARDINO COUNTY:

PERMITS SAN BERNARDINO: Hazardous Material Permits

This listing includes underground storage tanks, medical waste handlers/generators, hazardous materials handlers, hazardous waste generators, and waste oil generators/handlers.

GOVERNMENT RECORDS SEARCHED / DATA CURRENCY TRACKING

Date of Government Version: 05/12/2022
Date Data Arrived at EDR: 05/12/2022
Date Made Active in Reports: 05/18/2022
Number of Days to Update: 6

Source: San Bernardino County Fire Department Hazardous Materials Division
Telephone: 909-387-3041
Last EDR Contact: 04/28/2022
Next Scheduled EDR Contact: 08/15/2022
Data Release Frequency: Quarterly

SAN DIEGO COUNTY:

HMMD SAN DIEGO: Hazardous Materials Management Division Database

The database includes: HE58 - This report contains the business name, site address, business phone number, establishment 'H' permit number, type of permit, and the business status. HE17 - In addition to providing the same information provided in the HE58 listing, HE17 provides inspection dates, violations received by the establishment, hazardous waste generated, the quantity, method of storage, treatment/disposal of waste and the hauler, and information on underground storage tanks. Unauthorized Release List - Includes a summary of environmental contamination cases in San Diego County (underground tank cases, non-tank cases, groundwater contamination, and soil contamination are included.)

Date of Government Version: 02/28/2022
Date Data Arrived at EDR: 02/28/2022
Date Made Active in Reports: 05/25/2022
Number of Days to Update: 86

Source: Hazardous Materials Management Division
Telephone: 619-338-2268
Last EDR Contact: 05/31/2022
Next Scheduled EDR Contact: 09/12/2022
Data Release Frequency: Quarterly

LF SAN DIEGO: Solid Waste Facilities

San Diego County Solid Waste Facilities.

Date of Government Version: 10/27/2021
Date Data Arrived at EDR: 03/04/2022
Date Made Active in Reports: 05/31/2022
Number of Days to Update: 88

Source: Department of Health Services
Telephone: 619-338-2209
Last EDR Contact: 04/14/2022
Next Scheduled EDR Contact: 08/01/2022
Data Release Frequency: Varies

SAN DIEGO CO LOP: Local Oversight Program Listing

A listing of all LOP release sites that are or were under the County of San Diego's jurisdiction. Included are closed or transferred cases, open cases, and cases that did not have a case type indicated. The cases without a case type are mostly complaints; however, some of them could be LOP cases.

Date of Government Version: 07/22/2021
Date Data Arrived at EDR: 10/19/2021
Date Made Active in Reports: 01/13/2022
Number of Days to Update: 86

Source: Department of Environmental Health
Telephone: 858-505-6874
Last EDR Contact: 04/18/2022
Next Scheduled EDR Contact: 08/01/2022
Data Release Frequency: Varies

SAN DIEGO CO SAM: Environmental Case Listing

The listing contains all underground tank release cases and projects pertaining to properties contaminated with hazardous substances that are actively under review by the Site Assessment and Mitigation Program.

Date of Government Version: 03/23/2010
Date Data Arrived at EDR: 06/15/2010
Date Made Active in Reports: 07/09/2010
Number of Days to Update: 24

Source: San Diego County Department of Environmental Health
Telephone: 619-338-2371
Last EDR Contact: 05/25/2022
Next Scheduled EDR Contact: 09/12/2022
Data Release Frequency: No Update Planned

SAN FRANCISCO COUNTY:

CUPA SAN FRANCISCO CO: CUPA Facility Listing Cupa facilities

GOVERNMENT RECORDS SEARCHED / DATA CURRENCY TRACKING

Date of Government Version: 02/03/2022
Date Data Arrived at EDR: 02/04/2022
Date Made Active in Reports: 02/11/2022
Number of Days to Update: 7

Source: San Francisco County Department of Environmental Health
Telephone: 415-252-3896
Last EDR Contact: 04/28/2022
Next Scheduled EDR Contact: 08/15/2022
Data Release Frequency: Varies

LUST SAN FRANCISCO: Local Oversight Facilities

A listing of leaking underground storage tank sites located in San Francisco county.

Date of Government Version: 09/19/2008
Date Data Arrived at EDR: 09/19/2008
Date Made Active in Reports: 09/29/2008
Number of Days to Update: 10

Source: Department Of Public Health San Francisco County
Telephone: 415-252-3920
Last EDR Contact: 04/28/2022
Next Scheduled EDR Contact: 08/15/2022
Data Release Frequency: No Update Planned

UST SAN FRANCISCO: Underground Storage Tank Information

Underground storage tank sites located in San Francisco county.

Date of Government Version: 02/03/2022
Date Data Arrived at EDR: 02/04/2022
Date Made Active in Reports: 05/02/2022
Number of Days to Update: 87

Source: Department of Public Health
Telephone: 415-252-3920
Last EDR Contact: 04/28/2022
Next Scheduled EDR Contact: 08/15/2022
Data Release Frequency: Quarterly

SAN FRANCISCO COUNTY:

SAN FRANCISCO MAHER: Maher Ordinance Property Listing

a listing of properties that fall within a Maher Ordinance, for all of San Francisco

Date of Government Version: 01/18/2022
Date Data Arrived at EDR: 01/20/2022
Date Made Active in Reports: 04/27/2022
Number of Days to Update: 97

Source: San Francisco Planning
Telephone: 628-652-7483
Last EDR Contact: 05/06/2022
Next Scheduled EDR Contact: 08/01/2022
Data Release Frequency: Varies

SAN JOAQUIN COUNTY:

UST SAN JOAQUIN: San Joaquin Co. UST

A listing of underground storage tank locations in San Joaquin county.

Date of Government Version: 06/22/2018
Date Data Arrived at EDR: 06/26/2018
Date Made Active in Reports: 07/11/2018
Number of Days to Update: 15

Source: Environmental Health Department
Telephone: N/A
Last EDR Contact: 06/09/2022
Next Scheduled EDR Contact: 09/26/2022
Data Release Frequency: Semi-Annually

SAN LUIS OBISPO COUNTY:

CUPA SAN LUIS OBISPO: CUPA Facility List Cupa Facility List.

Date of Government Version: 02/15/2022
Date Data Arrived at EDR: 02/16/2022
Date Made Active in Reports: 05/13/2022
Number of Days to Update: 86

Source: San Luis Obispo County Public Health Department
Telephone: 805-781-5596
Last EDR Contact: 05/12/2022
Next Scheduled EDR Contact: 08/29/2022
Data Release Frequency: Varies

SAN MATEO COUNTY:

GOVERNMENT RECORDS SEARCHED / DATA CURRENCY TRACKING

BI SAN MATEO: Business Inventory

List includes Hazardous Materials Business Plan, hazardous waste generators, and underground storage tanks.

Date of Government Version: 02/20/2020

Date Data Arrived at EDR: 02/20/2020

Date Made Active in Reports: 04/24/2020

Number of Days to Update: 64

Source: San Mateo County Environmental Health Services Division

Telephone: 650-363-1921

Last EDR Contact: 06/10/2022

Next Scheduled EDR Contact: 09/19/2022

Data Release Frequency: Annually

LUST SAN MATEO: Fuel Leak List

A listing of leaking underground storage tank sites located in San Mateo county.

Date of Government Version: 03/29/2019

Date Data Arrived at EDR: 03/29/2019

Date Made Active in Reports: 05/29/2019

Number of Days to Update: 61

Source: San Mateo County Environmental Health Services Division

Telephone: 650-363-1921

Last EDR Contact: 06/02/2022

Next Scheduled EDR Contact: 09/19/2022

Data Release Frequency: Semi-Annually

SANTA BARBARA COUNTY:

CUPA SANTA BARBARA: CUPA Facility Listing

CUPA Program Listing from the Environmental Health Services division.

Date of Government Version: 09/08/2011

Date Data Arrived at EDR: 09/09/2011

Date Made Active in Reports: 10/07/2011

Number of Days to Update: 28

Source: Santa Barbara County Public Health Department

Telephone: 805-686-8167

Last EDR Contact: 05/12/2022

Next Scheduled EDR Contact: 08/29/2022

Data Release Frequency: No Update Planned

SANTA CLARA COUNTY:

CUPA SANTA CLARA: Cupa Facility List

Cupa facility list

Date of Government Version: 02/14/2022

Date Data Arrived at EDR: 02/16/2022

Date Made Active in Reports: 05/12/2022

Number of Days to Update: 85

Source: Department of Environmental Health

Telephone: 408-918-1973

Last EDR Contact: 05/12/2022

Next Scheduled EDR Contact: 08/29/2022

Data Release Frequency: Varies

HIST LUST SANTA CLARA: HIST LUST - Fuel Leak Site Activity Report

A listing of open and closed leaking underground storage tanks. This listing is no longer updated by the county. Leaking underground storage tanks are now handled by the Department of Environmental Health.

Date of Government Version: 03/29/2005

Date Data Arrived at EDR: 03/30/2005

Date Made Active in Reports: 04/21/2005

Number of Days to Update: 22

Source: Santa Clara Valley Water District

Telephone: 408-265-2600

Last EDR Contact: 03/23/2009

Next Scheduled EDR Contact: 06/22/2009

Data Release Frequency: No Update Planned

LUST SANTA CLARA: LOP Listing

A listing of leaking underground storage tanks located in Santa Clara county.

Date of Government Version: 03/03/2014

Date Data Arrived at EDR: 03/05/2014

Date Made Active in Reports: 03/18/2014

Number of Days to Update: 13

Source: Department of Environmental Health

Telephone: 408-918-3417

Last EDR Contact: 05/19/2022

Next Scheduled EDR Contact: 09/05/2022

Data Release Frequency: No Update Planned

GOVERNMENT RECORDS SEARCHED / DATA CURRENCY TRACKING

SAN JOSE HAZMAT: Hazardous Material Facilities

Hazardous material facilities, including underground storage tank sites.

Date of Government Version: 11/03/2020
Date Data Arrived at EDR: 11/05/2020
Date Made Active in Reports: 01/26/2021
Number of Days to Update: 82

Source: City of San Jose Fire Department
Telephone: 408-535-7694
Last EDR Contact: 04/28/2022
Next Scheduled EDR Contact: 08/15/2022
Data Release Frequency: Annually

SANTA CRUZ COUNTY:

CUPA SANTA CRUZ: CUPA Facility List CUPA facility listing.

Date of Government Version: 01/21/2017
Date Data Arrived at EDR: 02/22/2017
Date Made Active in Reports: 05/23/2017
Number of Days to Update: 90

Source: Santa Cruz County Environmental Health
Telephone: 831-464-2761
Last EDR Contact: 05/12/2022
Next Scheduled EDR Contact: 08/29/2022
Data Release Frequency: Varies

SHASTA COUNTY:

CUPA SHASTA: CUPA Facility List Cupa Facility List.

Date of Government Version: 06/15/2017
Date Data Arrived at EDR: 06/19/2017
Date Made Active in Reports: 08/09/2017
Number of Days to Update: 51

Source: Shasta County Department of Resource Management
Telephone: 530-225-5789
Last EDR Contact: 05/12/2022
Next Scheduled EDR Contact: 08/29/2022
Data Release Frequency: Varies

SOLANO COUNTY:

LUST SOLANO: Leaking Underground Storage Tanks

A listing of leaking underground storage tank sites located in Solano county.

Date of Government Version: 06/04/2019
Date Data Arrived at EDR: 06/06/2019
Date Made Active in Reports: 08/13/2019
Number of Days to Update: 68

Source: Solano County Department of Environmental Management
Telephone: 707-784-6770
Last EDR Contact: 05/25/2022
Next Scheduled EDR Contact: 09/12/2022
Data Release Frequency: Quarterly

UST SOLANO: Underground Storage Tanks

Underground storage tank sites located in Solano county.

Date of Government Version: 09/15/2021
Date Data Arrived at EDR: 09/16/2021
Date Made Active in Reports: 12/09/2021
Number of Days to Update: 84

Source: Solano County Department of Environmental Management
Telephone: 707-784-6770
Last EDR Contact: 05/25/2022
Next Scheduled EDR Contact: 09/12/2022
Data Release Frequency: Quarterly

SONOMA COUNTY:

CUPA SONOMA: Cupa Facility List Cupa Facility list

GOVERNMENT RECORDS SEARCHED / DATA CURRENCY TRACKING

Date of Government Version: 07/02/2021
Date Data Arrived at EDR: 07/06/2021
Date Made Active in Reports: 07/14/2021
Number of Days to Update: 8

Source: County of Sonoma Fire & Emergency Services Department
Telephone: 707-565-1174
Last EDR Contact: 06/14/2022
Next Scheduled EDR Contact: 10/03/2022
Data Release Frequency: Varies

LUST SONOMA: Leaking Underground Storage Tank Sites

A listing of leaking underground storage tank sites located in Sonoma county.

Date of Government Version: 06/30/2021
Date Data Arrived at EDR: 06/30/2021
Date Made Active in Reports: 09/24/2021
Number of Days to Update: 86

Source: Department of Health Services
Telephone: 707-565-6565
Last EDR Contact: 06/14/2022
Next Scheduled EDR Contact: 10/04/2021
Data Release Frequency: Quarterly

STANISLAUS COUNTY:

CUPA STANISLAUS: CUPA Facility List

Cupa facility list

Date of Government Version: 02/08/2022
Date Data Arrived at EDR: 02/10/2022
Date Made Active in Reports: 05/04/2022
Number of Days to Update: 83

Source: Stanislaus County Department of Environmental Protection
Telephone: 209-525-6751
Last EDR Contact: 04/11/2022
Next Scheduled EDR Contact: 07/25/2022
Data Release Frequency: Varies

SUTTER COUNTY:

UST SUTTER: Underground Storage Tanks

Underground storage tank sites located in Sutter county.

Date of Government Version: 11/23/2021
Date Data Arrived at EDR: 11/29/2021
Date Made Active in Reports: 02/11/2022
Number of Days to Update: 74

Source: Sutter County Environmental Health Services
Telephone: 530-822-7500
Last EDR Contact: 05/25/2022
Next Scheduled EDR Contact: 09/12/2022
Data Release Frequency: Semi-Annually

TEHAMA COUNTY:

CUPA TEHAMA: CUPA Facility List

Cupa facilities

Date of Government Version: 01/13/2021
Date Data Arrived at EDR: 01/14/2021
Date Made Active in Reports: 04/06/2021
Number of Days to Update: 82

Source: Tehama County Department of Environmental Health
Telephone: 530-527-8020
Last EDR Contact: 04/28/2022
Next Scheduled EDR Contact: 08/15/2022
Data Release Frequency: Varies

TRINITY COUNTY:

CUPA TRINITY: CUPA Facility List

Cupa facility list

Date of Government Version: 01/13/2022
Date Data Arrived at EDR: 01/14/2022
Date Made Active in Reports: 04/06/2022
Number of Days to Update: 82

Source: Department of Toxic Substances Control
Telephone: 760-352-0381
Last EDR Contact: 04/18/2022
Next Scheduled EDR Contact: 08/01/2022
Data Release Frequency: Varies

TULARE COUNTY:

GOVERNMENT RECORDS SEARCHED / DATA CURRENCY TRACKING

CUPA TULARE: CUPA Facility List Cupa program facilities

Date of Government Version: 04/26/2021
Date Data Arrived at EDR: 04/28/2021
Date Made Active in Reports: 07/13/2021
Number of Days to Update: 76

Source: Tulare County Environmental Health Services Division
Telephone: 559-624-7400
Last EDR Contact: 04/14/2022
Next Scheduled EDR Contact: 08/15/2022
Data Release Frequency: Varies

TUOLUMNE COUNTY:

CUPA TUOLUMNE: CUPA Facility List Cupa facility list

Date of Government Version: 04/23/2018
Date Data Arrived at EDR: 04/25/2018
Date Made Active in Reports: 06/25/2018
Number of Days to Update: 61

Source: Divison of Environmental Health
Telephone: 209-533-5633
Last EDR Contact: 04/14/2022
Next Scheduled EDR Contact: 08/01/2022
Data Release Frequency: Varies

VENTURA COUNTY:

BWT VENTURA: Business Plan, Hazardous Waste Producers, and Operating Underground Tanks The BWT list indicates by site address whether the Environmental Health Division has Business Plan (B), Waste Producer (W), and/or Underground Tank (T) information.

Date of Government Version: 12/27/2021
Date Data Arrived at EDR: 01/20/2022
Date Made Active in Reports: 04/08/2022
Number of Days to Update: 78

Source: Ventura County Environmental Health Division
Telephone: 805-654-2813
Last EDR Contact: 04/18/2022
Next Scheduled EDR Contact: 08/01/2022
Data Release Frequency: Quarterly

LF VENTURA: Inventory of Illegal Abandoned and Inactive Sites Ventura County Inventory of Closed, Illegal Abandoned, and Inactive Sites.

Date of Government Version: 12/01/2011
Date Data Arrived at EDR: 12/01/2011
Date Made Active in Reports: 01/19/2012
Number of Days to Update: 49

Source: Environmental Health Division
Telephone: 805-654-2813
Last EDR Contact: 03/23/2022
Next Scheduled EDR Contact: 07/11/2022
Data Release Frequency: No Update Planned

LUST VENTURA: Listing of Underground Tank Cleanup Sites Ventura County Underground Storage Tank Cleanup Sites (LUST).

Date of Government Version: 05/29/2008
Date Data Arrived at EDR: 06/24/2008
Date Made Active in Reports: 07/31/2008
Number of Days to Update: 37

Source: Environmental Health Division
Telephone: 805-654-2813
Last EDR Contact: 05/04/2022
Next Scheduled EDR Contact: 08/22/2022
Data Release Frequency: No Update Planned

MED WASTE VENTURA: Medical Waste Program List

To protect public health and safety and the environment from potential exposure to disease causing agents, the Environmental Health Division Medical Waste Program regulates the generation, handling, storage, treatment and disposal of medical waste throughout the County.

Date of Government Version: 12/27/2021
Date Data Arrived at EDR: 01/20/2022
Date Made Active in Reports: 04/11/2022
Number of Days to Update: 81

Source: Ventura County Resource Management Agency
Telephone: 805-654-2813
Last EDR Contact: 04/18/2022
Next Scheduled EDR Contact: 08/01/2022
Data Release Frequency: Quarterly

GOVERNMENT RECORDS SEARCHED / DATA CURRENCY TRACKING

UST VENTURA: Underground Tank Closed Sites List

Ventura County Operating Underground Storage Tank Sites (UST)/Underground Tank Closed Sites List.

Date of Government Version: 02/28/2022	Source: Environmental Health Division
Date Data Arrived at EDR: 03/08/2022	Telephone: 805-654-2813
Date Made Active in Reports: 06/02/2022	Last EDR Contact: 06/07/2022
Number of Days to Update: 86	Next Scheduled EDR Contact: 09/19/2022
	Data Release Frequency: Quarterly

YOLO COUNTY:

UST YOLO: Underground Storage Tank Comprehensive Facility Report

Underground storage tank sites located in Yolo county.

Date of Government Version: 12/27/2021	Source: Yolo County Department of Health
Date Data Arrived at EDR: 01/04/2022	Telephone: 530-666-8646
Date Made Active in Reports: 03/18/2022	Last EDR Contact: 03/24/2022
Number of Days to Update: 73	Next Scheduled EDR Contact: 07/11/2022
	Data Release Frequency: Annually

YUBA COUNTY:

CUPA YUBA: CUPA Facility List

CUPA facility listing for Yuba County.

Date of Government Version: 01/26/2022	Source: Yuba County Environmental Health Department
Date Data Arrived at EDR: 01/27/2022	Telephone: 530-749-7523
Date Made Active in Reports: 04/14/2022	Last EDR Contact: 04/21/2022
Number of Days to Update: 77	Next Scheduled EDR Contact: 08/08/2022
	Data Release Frequency: Varies

OTHER DATABASE(S)

Depending on the geographic area covered by this report, the data provided in these specialty databases may or may not be complete. For example, the existence of wetlands information data in a specific report does not mean that all wetlands in the area covered by the report are included. Moreover, the absence of any reported wetlands information does not necessarily mean that wetlands do not exist in the area covered by the report.

CT MANIFEST: Hazardous Waste Manifest Data

Facility and manifest data. Manifest is a document that lists and tracks hazardous waste from the generator through transporters to a tsd facility.

Date of Government Version: 12/03/2021	Source: Department of Energy & Environmental Protection
Date Data Arrived at EDR: 02/11/2022	Telephone: 860-424-3375
Date Made Active in Reports: 05/06/2022	Last EDR Contact: 05/09/2022
Number of Days to Update: 84	Next Scheduled EDR Contact: 08/22/2022
	Data Release Frequency: No Update Planned

NJ MANIFEST: Manifest Information

Hazardous waste manifest information.

Date of Government Version: 12/31/2018	Source: Department of Environmental Protection
Date Data Arrived at EDR: 04/10/2019	Telephone: N/A
Date Made Active in Reports: 05/16/2019	Last EDR Contact: 04/07/2022
Number of Days to Update: 36	Next Scheduled EDR Contact: 07/18/2022
	Data Release Frequency: Annually

GOVERNMENT RECORDS SEARCHED / DATA CURRENCY TRACKING

NY MANIFEST: Facility and Manifest Data

Manifest is a document that lists and tracks hazardous waste from the generator through transporters to a TSD facility.

Date of Government Version: 01/01/2019
Date Data Arrived at EDR: 10/29/2021
Date Made Active in Reports: 01/19/2022
Number of Days to Update: 82

Source: Department of Environmental Conservation
Telephone: 518-402-8651
Last EDR Contact: 04/28/2022
Next Scheduled EDR Contact: 08/08/2022
Data Release Frequency: Quarterly

PA MANIFEST: Manifest Information

Hazardous waste manifest information.

Date of Government Version: 06/30/2018
Date Data Arrived at EDR: 07/19/2019
Date Made Active in Reports: 09/10/2019
Number of Days to Update: 53

Source: Department of Environmental Protection
Telephone: 717-783-8990
Last EDR Contact: 04/08/2022
Next Scheduled EDR Contact: 07/25/2022
Data Release Frequency: Annually

RI MANIFEST: Manifest information

Hazardous waste manifest information

Date of Government Version: 12/31/2018
Date Data Arrived at EDR: 11/30/2021
Date Made Active in Reports: 02/18/2022
Number of Days to Update: 80

Source: Department of Environmental Management
Telephone: 401-222-2797
Last EDR Contact: 05/16/2022
Next Scheduled EDR Contact: 08/29/2022
Data Release Frequency: Annually

WI MANIFEST: Manifest Information

Hazardous waste manifest information.

Date of Government Version: 05/31/2018
Date Data Arrived at EDR: 06/19/2019
Date Made Active in Reports: 09/03/2019
Number of Days to Update: 76

Source: Department of Natural Resources
Telephone: N/A
Last EDR Contact: 06/03/2022
Next Scheduled EDR Contact: 09/19/2022
Data Release Frequency: Annually

Oil/Gas Pipelines

Source: Endeavor Business Media

Petroleum Bundle (Crude Oil, Refined Products, Petrochemicals, Gas Liquids (LPG/NGL), and Specialty Gases (Miscellaneous)) N = Natural Gas Bundle (Natural Gas, Gas Liquids (LPG/NGL), and Specialty Gases (Miscellaneous)). This map includes information copyrighted by Endeavor Business Media. This information is provided on a best effort basis and Endeavor Business Media does not guarantee its accuracy nor warrant its fitness for any particular purpose. Such information has been reprinted with the permission of Endeavor Business Media.

Electric Power Transmission Line Data

Source: Endeavor Business Media

This map includes information copyrighted by Endeavor Business Media. This information is provided on a best effort basis and Endeavor Business Media does not guarantee its accuracy nor warrant its fitness for any particular purpose. Such information has been reprinted with the permission of Endeavor Business Media.

Sensitive Receptors: There are individuals deemed sensitive receptors due to their fragile immune systems and special sensitivity to environmental discharges. These sensitive receptors typically include the elderly, the sick, and children. While the location of all sensitive receptors cannot be determined, EDR indicates those buildings and facilities - schools, daycares, hospitals, medical centers, and nursing homes - where individuals who are sensitive receptors are likely to be located.

AHA Hospitals:

Source: American Hospital Association, Inc.
Telephone: 312-280-5991

The database includes a listing of hospitals based on the American Hospital Association's annual survey of hospitals.

Medical Centers: Provider of Services Listing

Source: Centers for Medicare & Medicaid Services
Telephone: 410-786-3000

A listing of hospitals with Medicare provider number, produced by Centers of Medicare & Medicaid Services, a federal agency within the U.S. Department of Health and Human Services.

GOVERNMENT RECORDS SEARCHED / DATA CURRENCY TRACKING

Nursing Homes

Source: National Institutes of Health

Telephone: 301-594-6248

Information on Medicare and Medicaid certified nursing homes in the United States.

Public Schools

Source: National Center for Education Statistics

Telephone: 202-502-7300

The National Center for Education Statistics' primary database on elementary and secondary public education in the United States. It is a comprehensive, annual, national statistical database of all public elementary and secondary schools and school districts, which contains data that are comparable across all states.

Private Schools

Source: National Center for Education Statistics

Telephone: 202-502-7300

The National Center for Education Statistics' primary database on private school locations in the United States.

Daycare Centers: Licensed Facilities

Source: Department of Social Services

Telephone: 916-657-4041

Flood Zone Data: This data was obtained from the Federal Emergency Management Agency (FEMA). It depicts 100-year and 500-year flood zones as defined by FEMA. It includes the National Flood Hazard Layer (NFHL) which incorporates Flood Insurance Rate Map (FIRM) data and Q3 data from FEMA in areas not covered by NFHL.

Source: FEMA

Telephone: 877-336-2627

Date of Government Version: 2003, 2015

NWI: National Wetlands Inventory. This data, available in select counties across the country, was obtained by EDR in 2002, 2005 and 2010 from the U.S. Fish and Wildlife Service.

State Wetlands Data: Wetland Inventory

Source: Department of Fish and Wildlife

Telephone: 916-445-0411

Current USGS 7.5 Minute Topographic Map

Source: U.S. Geological Survey

STREET AND ADDRESS INFORMATION

Â© 2015 TomTom North America, Inc. All rights reserved. This material is proprietary and the subject of copyright protection and other intellectual property rights owned by or licensed to Tele Atlas North America, Inc. The use of this material is subject to the terms of a license agreement. You will be held liable for any unauthorized copying or disclosure of this material.

GEOCHECK[®] - PHYSICAL SETTING SOURCE ADDENDUM

TARGET PROPERTY ADDRESS

NORTHSTAR 1 SOLAR PROJECT
EHL CANAL AND NILAND LATERAL 6
CALIPATRIA, CA 92233

TARGET PROPERTY COORDINATES

Latitude (North):	33.333838 - 33° 20' 1.82"
Longitude (West):	115.570058 - 115° 34' 12.21"
Universal Transverse Mercator:	Zone 11
UTM X (Meters):	633082.4
UTM Y (Meters):	3689017.8
Elevation:	31 ft. below sea level

USGS TOPOGRAPHIC MAP

Target Property Map:	11994450 WISTER, CA
Version Date:	2018

EDR's GeoCheck Physical Setting Source Addendum is provided to assist the environmental professional in forming an opinion about the impact of potential contaminant migration.

Assessment of the impact of contaminant migration generally has two principle investigative components:

1. Groundwater flow direction, and
2. Groundwater flow velocity.

Groundwater flow direction may be impacted by surface topography, hydrology, hydrogeology, characteristics of the soil, and nearby wells. Groundwater flow velocity is generally impacted by the nature of the geologic strata.

GEOCHECK® - PHYSICAL SETTING SOURCE SUMMARY

GROUNDWATER FLOW DIRECTION INFORMATION

Groundwater flow direction for a particular site is best determined by a qualified environmental professional using site-specific well data. If such data is not reasonably ascertainable, it may be necessary to rely on other sources of information, such as surface topographic information, hydrologic information, hydrogeologic data collected on nearby properties, and regional groundwater flow information (from deep aquifers).

TOPOGRAPHIC INFORMATION

Surface topography may be indicative of the direction of surficial groundwater flow. This information can be used to assist the environmental professional in forming an opinion about the impact of nearby contaminated properties or, should contamination exist on the target property, what downgradient sites might be impacted.

TARGET PROPERTY TOPOGRAPHY

General Topographic Gradient: General SW

SURROUNDING TOPOGRAPHY: ELEVATION PROFILES

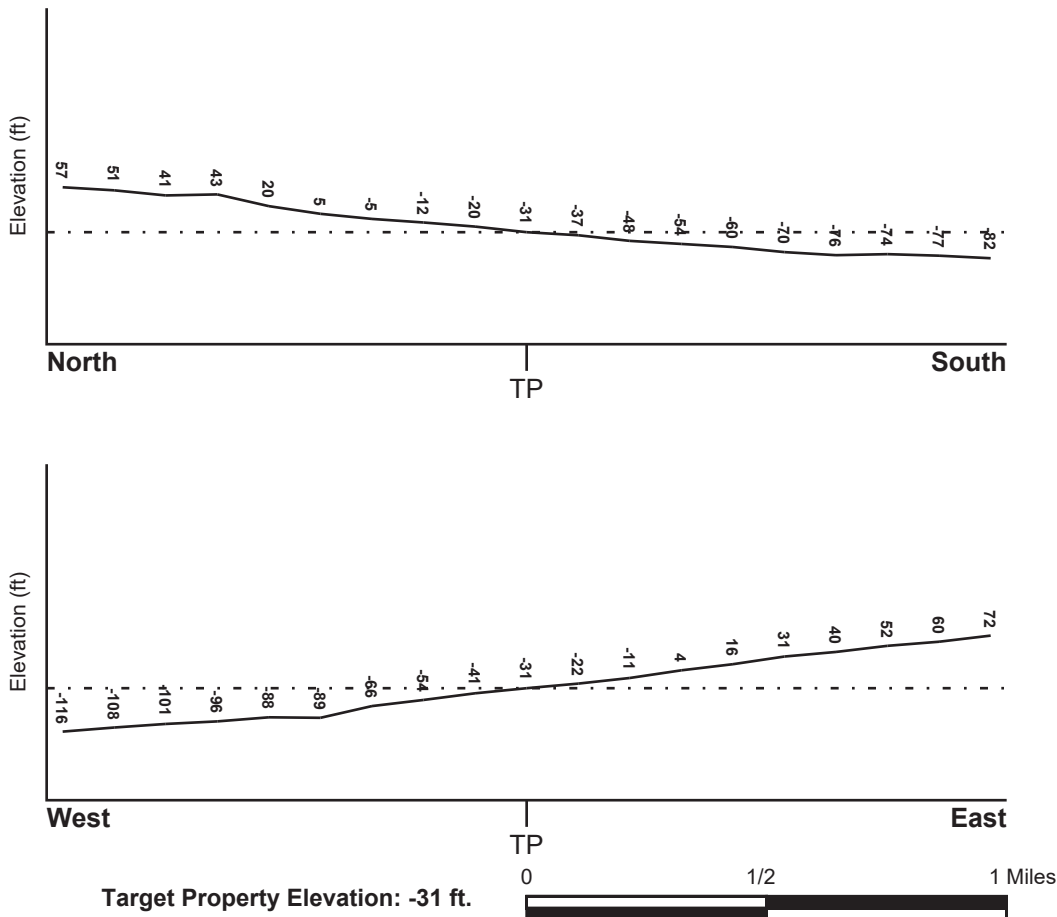

Source: Topography has been determined from the USGS 7.5' Digital Elevation Model and should be evaluated on a relative (not an absolute) basis. Relative elevation information between sites of close proximity should be field verified.

GEOCHECK® - PHYSICAL SETTING SOURCE SUMMARY

HYDROLOGIC INFORMATION

Surface water can act as a hydrologic barrier to groundwater flow. Such hydrologic information can be used to assist the environmental professional in forming an opinion about the impact of nearby contaminated properties or, should contamination exist on the target property, what downgradient sites might be impacted.

Refer to the Physical Setting Source Map following this summary for hydrologic information (major waterways and bodies of water).

FEMA FLOOD ZONE

<u>Flood Plain Panel at Target Property</u>	<u>FEMA Source Type</u>
06025C0425C	FEMA FIRM Flood data
<u>Additional Panels in search area:</u>	<u>FEMA Source Type</u>
Not Reported	

NATIONAL WETLAND INVENTORY

<u>NWI Quad at Target Property</u>	<u>NWI Electronic Data Coverage</u>
WISTER	YES - refer to the Overview Map and Detail Map

HYDROGEOLOGIC INFORMATION

Hydrogeologic information obtained by installation of wells on a specific site can often be an indicator of groundwater flow direction in the immediate area. Such hydrogeologic information can be used to assist the environmental professional in forming an opinion about the impact of nearby contaminated properties or, should contamination exist on the target property, what downgradient sites might be impacted.

Site-Specific Hydrogeological Data*:

Search Radius:	1.25 miles
Status:	Not found

AQUIFLOW®

Search Radius: 1.000 Mile.

EDR has developed the AQUIFLOW Information System to provide data on the general direction of groundwater flow at specific points. EDR has reviewed reports submitted by environmental professionals to regulatory authorities at select sites and has extracted the date of the report, groundwater flow direction as determined hydrogeologically, and the depth to water table.

<u>MAP ID</u>	<u>LOCATION FROM TP</u>	<u>GENERAL DIRECTION GROUNDWATER FLOW</u>
Not Reported		

GEOCHECK® - PHYSICAL SETTING SOURCE SUMMARY

GROUNDWATER FLOW VELOCITY INFORMATION

Groundwater flow velocity information for a particular site is best determined by a qualified environmental professional using site specific geologic and soil strata data. If such data are not reasonably ascertainable, it may be necessary to rely on other sources of information, including geologic age identification, rock stratigraphic unit and soil characteristics data collected on nearby properties and regional soil information. In general, contaminant plumes move more quickly through sandy-gravelly types of soils than silty-clayey types of soils.

GEOLOGIC INFORMATION IN GENERAL AREA OF TARGET PROPERTY

Geologic information can be used by the environmental professional in forming an opinion about the relative speed at which contaminant migration may be occurring.

ROCK STRATIGRAPHIC UNIT

Era: Cenozoic
System: Quaternary
Series: Quaternary
Code: Q (*decoded above as Era, System & Series*)

GEOLOGIC AGE IDENTIFICATION

Category: Stratified Sequence

Geologic Age and Rock Stratigraphic Unit Source: P.G. Schruben, R.E. Arndt and W.J. Bawiec, Geology of the Conterminous U.S. at 1:2,500,000 Scale - a digital representation of the 1974 P.B. King and H.M. Beikman Map, USGS Digital Data Series DDS - 11 (1994).

SSURGO SOIL MAP - 7022950.2s

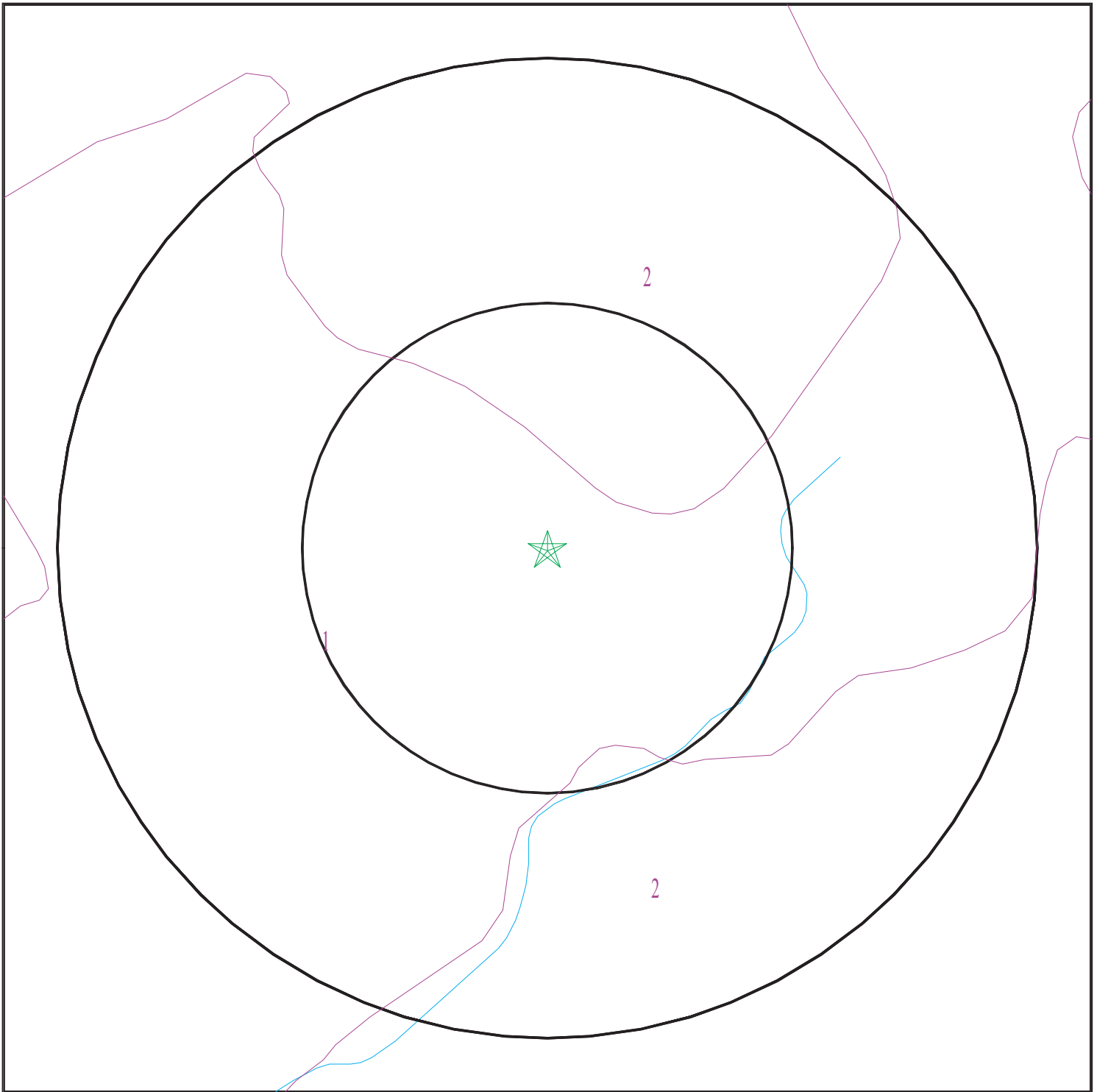

- ★ Target Property
- ∩ SSURGO Soil
- ∩ Water

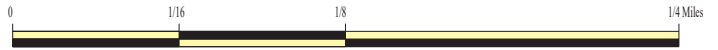

SITE NAME: Northstar 1 Solar Project
ADDRESS: EHL Canal and Niland Lateral 6
Calipatria CA 92233
LAT/LONG: 33.333838 / 115.570058

CLIENT: GS Lyon Consultants
CONTACT: Steven Williams
INQUIRY #: 7022950.2s
DATE: June 17, 2022 12:55 pm

GEOCHECK® - PHYSICAL SETTING SOURCE SUMMARY

DOMINANT SOIL COMPOSITION IN GENERAL AREA OF TARGET PROPERTY

The U.S. Department of Agriculture's (USDA) Soil Conservation Service (SCS) leads the National Cooperative Soil Survey (NCSS) and is responsible for collecting, storing, maintaining and distributing soil survey information for privately owned lands in the United States. A soil map in a soil survey is a representation of soil patterns in a landscape. The following information is based on Soil Conservation Service SSURGO data.

Soil Map ID: 1

Soil Component Name: Niland

Soil Surface Texture: gravelly sand

Hydrologic Group: Class C - Slow infiltration rates. Soils with layers impeding downward movement of water, or soils with moderately fine or fine textures.

Soil Drainage Class: Moderately well drained

Hydric Status: Partially hydric

Corrosion Potential - Uncoated Steel: High

Depth to Bedrock Min: > 0 inches

Depth to Watertable Min: > 76 inches

Soil Layer Information							
Layer	Boundary		Soil Texture Class	Classification		Saturated hydraulic conductivity micro m/sec	Soil Reaction (pH)
	Upper	Lower		AASHTO Group	Unified Soil		
1	0 inches	22 inches	gravelly sand	A-1-b	FINE-GRAINED SOILS, Silts and Clays (liquid limit 50% or more), Fat Clay.	Max: 1.4 Min: 0.42	Max: 8.4 Min: 7.9
2	22 inches	59 inches	silty clay	A-1-b	FINE-GRAINED SOILS, Silts and Clays (liquid limit 50% or more), Fat Clay.	Max: 1.4 Min: 0.42	Max: 8.4 Min: 7.9

Soil Map ID: 2

Soil Component Name: Niland

Soil Surface Texture: gravelly sand

Hydrologic Group: Class C - Slow infiltration rates. Soils with layers impeding downward movement of water, or soils with moderately fine or fine textures.

Soil Drainage Class: Moderately well drained

GEOCHECK® - PHYSICAL SETTING SOURCE SUMMARY

Hydric Status: Partially hydric

Corrosion Potential - Uncoated Steel: High

Depth to Bedrock Min: > 0 inches

Depth to Watertable Min: > 0 inches

Soil Layer Information							
Layer	Boundary		Soil Texture Class	Classification		Saturated hydraulic conductivity micro m/sec	Soil Reaction (pH)
	Upper	Lower		AASHTO Group	Unified Soil		
1	0 inches	22 inches	gravelly sand	A-1-b	FINE-GRAINED SOILS, Silts and Clays (liquid limit 50% or more), Fat Clay.	Max: 1.4 Min: 0.42	Max: 8.4 Min: 7.9
2	22 inches	59 inches	silty clay	A-1-b	FINE-GRAINED SOILS, Silts and Clays (liquid limit 50% or more), Fat Clay.	Max: 1.4 Min: 0.42	Max: 8.4 Min: 7.9

LOCAL / REGIONAL WATER AGENCY RECORDS

EDR Local/Regional Water Agency records provide water well information to assist the environmental professional in assessing sources that may impact ground water flow direction, and in forming an opinion about the impact of contaminant migration on nearby drinking water wells.

WELL SEARCH DISTANCE INFORMATION

<u>DATABASE</u>	<u>SEARCH DISTANCE (miles)</u>
Federal USGS	1.000
Federal FRDS PWS	Nearest PWS within 1 mile
State Database	1.000

FEDERAL USGS WELL INFORMATION

<u>MAP ID</u>	<u>WELL ID</u>	<u>LOCATION FROM TP</u>
No Wells Found		

FEDERAL FRDS PUBLIC WATER SUPPLY SYSTEM INFORMATION

<u>MAP ID</u>	<u>WELL ID</u>	<u>LOCATION FROM TP</u>
No PWS System Found		

Note: PWS System location is not always the same as well location.

GEOCHECK® - PHYSICAL SETTING SOURCE SUMMARY

STATE DATABASE WELL INFORMATION

MAP ID







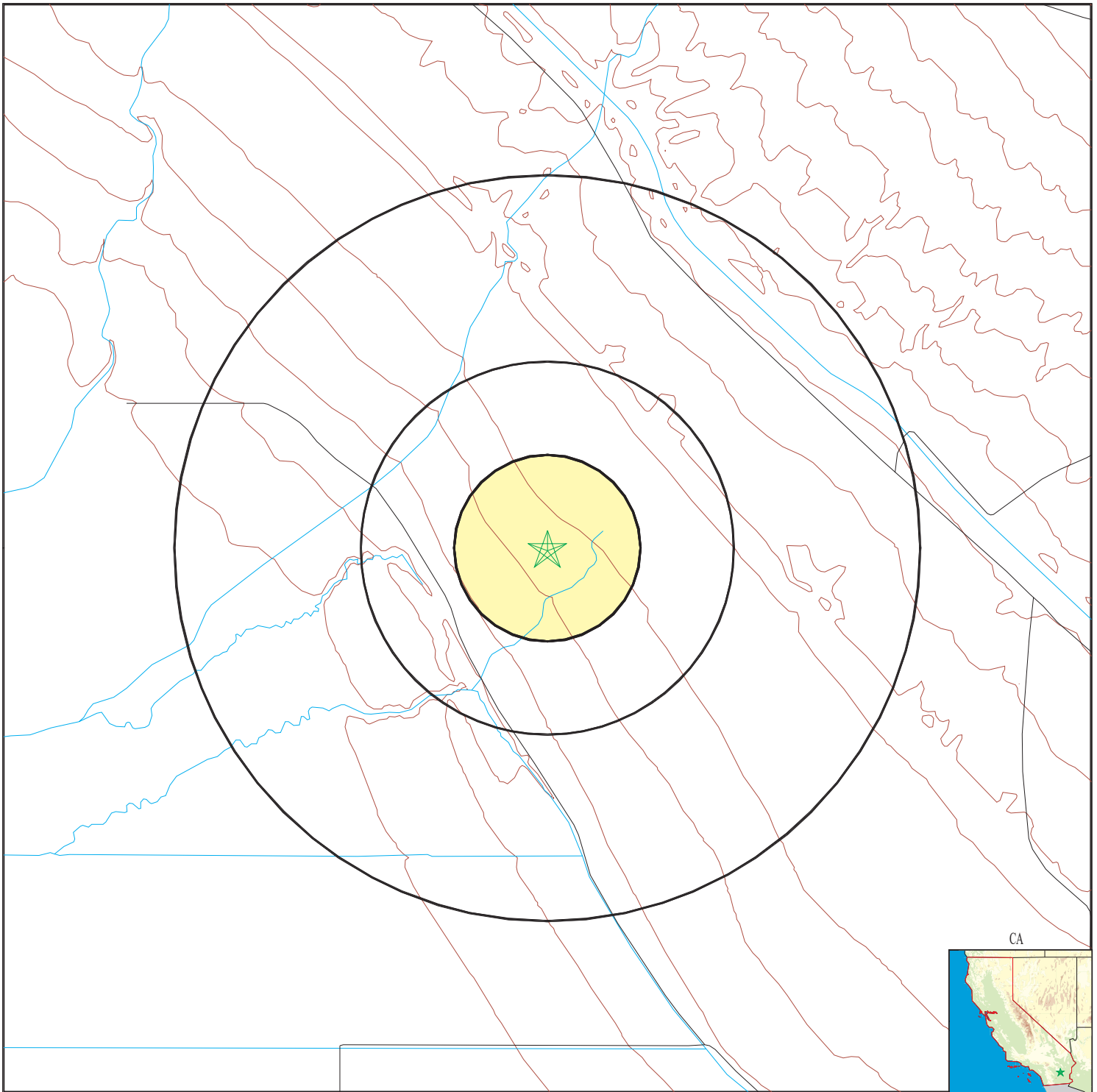

WELL ID

LOCATION
FROM TP





No Wells Found

PHYSICAL SETTING SOURCE MAP - 7022950.2s

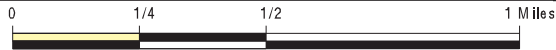

-  County Boundary
-  Major Roads
-  Contour Lines
-  Earthquake Fault Lines
-  Earthquake epicenter, Richter 5 or greater
-  Water Wells
-  Public Water Supply Wells
-  Cluster of Multiple Icons



-  Groundwater Flow Direction
-  Indeterminate Groundwater Flow at Location
-  Groundwater Flow Varies at Location
-  Closest Hydrogeological Data
-  Oil, gas or related wells



SITE NAME: Northstar 1 Solar Project
 ADDRESS: EHL Canal and Niland Lateral 6
 Calipatria CA 92233
 LAT/LONG: 33.333838 / 115.570058

CLIENT: GS Lyon Consultants
 CONTACT: Steven Williams
 INQUIRY #: 7022950.2s
 DATE: June 17, 2022 12:55 pm

GEOCHECK® - PHYSICAL SETTING SOURCE MAP FINDINGS RADON

AREA RADON INFORMATION

Federal EPA Radon Zone for IMPERIAL County: 3

- Note: Zone 1 indoor average level > 4 pCi/L.
 : Zone 2 indoor average level >= 2 pCi/L and <= 4 pCi/L.
 : Zone 3 indoor average level < 2 pCi/L.

Federal Area Radon Information for IMPERIAL COUNTY, CA

Number of sites tested: 2

Area	Average Activity	% <4 pCi/L	% 4-20 pCi/L	% >20 pCi/L
Living Area - 1st Floor	1.450 pCi/L	100%	0%	0%
Living Area - 2nd Floor	Not Reported	Not Reported	Not Reported	Not Reported
Basement	Not Reported	Not Reported	Not Reported	Not Reported

PHYSICAL SETTING SOURCE RECORDS SEARCHED

TOPOGRAPHIC INFORMATION

USGS 7.5' Digital Elevation Model (DEM)

Source: United States Geologic Survey

EDR acquired the USGS 7.5' Digital Elevation Model in 2002 and updated it in 2006. The 7.5 minute DEM corresponds to the USGS 1:24,000- and 1:25,000-scale topographic quadrangle maps. The DEM provides elevation data with consistent elevation units and projection.

Current USGS 7.5 Minute Topographic Map

Source: U.S. Geological Survey

HYDROLOGIC INFORMATION

Flood Zone Data: This data was obtained from the Federal Emergency Management Agency (FEMA). It depicts 100-year and 500-year flood zones as defined by FEMA. It includes the National Flood Hazard Layer (NFHL) which incorporates Flood Insurance Rate Map (FIRM) data and Q3 data from FEMA in areas not covered by NFHL.

Source: FEMA

Telephone: 877-336-2627

Date of Government Version: 2003, 2015

NWI: National Wetlands Inventory. This data, available in select counties across the country, was obtained by EDR in 2002, 2005 and 2010 from the U.S. Fish and Wildlife Service.

State Wetlands Data: Wetland Inventory

Source: Department of Fish and Wildlife

Telephone: 916-445-0411

HYDROGEOLOGIC INFORMATION

AQUIFLOW^R Information System

Source: EDR proprietary database of groundwater flow information

EDR has developed the AQUIFLOW Information System (AIS) to provide data on the general direction of groundwater flow at specific points. EDR has reviewed reports submitted to regulatory authorities at select sites and has extracted the date of the report, hydrogeologically determined groundwater flow direction and depth to water table information.

GEOLOGIC INFORMATION

Geologic Age and Rock Stratigraphic Unit

Source: P.G. Schruben, R.E. Arndt and W.J. Bawiec, Geology of the Conterminous U.S. at 1:2,500,000 Scale - A digital representation of the 1974 P.B. King and H.M. Beikman Map, USGS Digital Data Series DDS - 11 (1994).

STATSGO: State Soil Geographic Database

Source: Department of Agriculture, Natural Resources Conservation Service (NRCS)

The U.S. Department of Agriculture's (USDA) Natural Resources Conservation Service (NRCS) leads the national Conservation Soil Survey (NCSS) and is responsible for collecting, storing, maintaining and distributing soil survey information for privately owned lands in the United States. A soil map in a soil survey is a representation of soil patterns in a landscape. Soil maps for STATSGO are compiled by generalizing more detailed (SSURGO) soil survey maps.

SSURGO: Soil Survey Geographic Database

Source: Department of Agriculture, Natural Resources Conservation Service (NRCS)

Telephone: 800-672-5559

SSURGO is the most detailed level of mapping done by the Natural Resources Conservation Service, mapping scales generally range from 1:12,000 to 1:63,360. Field mapping methods using national standards are used to construct the soil maps in the Soil Survey Geographic (SSURGO) database. SSURGO digitizing duplicates the original soil survey maps. This level of mapping is designed for use by landowners, townships and county natural resource planning and management.

PHYSICAL SETTING SOURCE RECORDS SEARCHED

LOCAL / REGIONAL WATER AGENCY RECORDS

FEDERAL WATER WELLS

PWS: Public Water Systems

Source: EPA/Office of Drinking Water

Telephone: 202-564-3750

Public Water System data from the Federal Reporting Data System. A PWS is any water system which provides water to at least 25 people for at least 60 days annually. PWSs provide water from wells, rivers and other sources.

PWS ENF: Public Water Systems Violation and Enforcement Data

Source: EPA/Office of Drinking Water

Telephone: 202-564-3750

Violation and Enforcement data for Public Water Systems from the Safe Drinking Water Information System (SDWIS) after August 1995. Prior to August 1995, the data came from the Federal Reporting Data System (FRDS).

USGS Water Wells: USGS National Water Inventory System (NWIS)

This database contains descriptive information on sites where the USGS collects or has collected data on surface water and/or groundwater. The groundwater data includes information on wells, springs, and other sources of groundwater.

OTHER STATE DATABASE INFORMATION

Groundwater Ambient Monitoring & Assessment Program

State Water Resources Control Board

Telephone: 916-341-5577

The GAMA Program is California's comprehensive groundwater quality monitoring program. GAMA collects data by testing the untreated, raw water in different types of wells for naturally-occurring and man-made chemicals. The GAMA data includes Domestic, Monitoring and Municipal well types from the following sources, Department of Water Resources, Department of Health Services, EDF, Agricultural Lands, Lawrence Livermore National Laboratory, Department of Pesticide Regulation, United States Geological Survey, Groundwater Ambient Monitoring and Assessment Program and Local Groundwater Projects.

Water Well Database

Source: Department of Water Resources

Telephone: 916-651-9648

California Drinking Water Quality Database

Source: Department of Public Health

Telephone: 916-324-2319

The database includes all drinking water compliance and special studies monitoring for the state of California since 1984. It consists of over 3,200,000 individual analyses along with well and water system information.

California Oil and Gas Well Locations

Source: Dept of Conservation, Geologic Energy Management Division

Telephone: 916-323-1779

Oil and Gas well locations in the state.

California Earthquake Fault Lines

Source: California Division of Mines and Geology

The fault lines displayed on EDR's Topographic map are digitized quaternary fault lines prepared in 1975 by the United State Geological Survey. Additional information (also from 1975) regarding activity at specific fault lines comes from California's Preliminary Fault Activity Map prepared by the California Division of Mines and Geology.

RADON

State Database: CA Radon

Source: Department of Public Health

Telephone: 916-210-8558

Radon Database for California

PHYSICAL SETTING SOURCE RECORDS SEARCHED

Area Radon Information

Source: USGS

Telephone: 703-356-4020

The National Radon Database has been developed by the U.S. Environmental Protection Agency (USEPA) and is a compilation of the EPA/State Residential Radon Survey and the National Residential Radon Survey. The study covers the years 1986 - 1992. Where necessary data has been supplemented by information collected at private sources such as universities and research institutions.

EPA Radon Zones

Source: EPA

Telephone: 703-356-4020

Sections 307 & 309 of IRAA directed EPA to list and identify areas of U.S. with the potential for elevated indoor radon levels.

OTHER

Airport Landing Facilities: Private and public use landing facilities

Source: Federal Aviation Administration, 800-457-6656

Epicenters: World earthquake epicenters, Richter 5 or greater

Source: Department of Commerce, National Oceanic and Atmospheric Administration

California Earthquake Fault Lines: The fault lines displayed on EDR's Topographic map are digitized quaternary fault lines, prepared in 1975 by the United State Geological Survey. Additional information (also from 1975) regarding activity at specific fault lines comes from California's Preliminary Fault Activity Map prepared by the California Division of Mines and Geology.

STREET AND ADDRESS INFORMATION

© 2015 TomTom North America, Inc. All rights reserved. This material is proprietary and the subject of copyright protection and other intellectual property rights owned by or licensed to Tele Atlas North America, Inc. The use of this material is subject to the terms of a license agreement. You will be held liable for any unauthorized copying or disclosure of this material.

APPENDIX G

Sites and Facilities

Cleanup Sites

- Federal Superfund
- State Response
- Voluntary Cleanup
- School Cleanup
- Evaluation
- School Investigation
- Military Evaluation
- Tiered Permit
- Corrective Action
- Field Points

STATUS

All Statuses

Permitted Sites

- Operating
- Post-Closure
- Non-Operating

Other Sites

GIS Layers

Tools

[TAKE A TOUR](#) [SHARE THIS MAP](#)

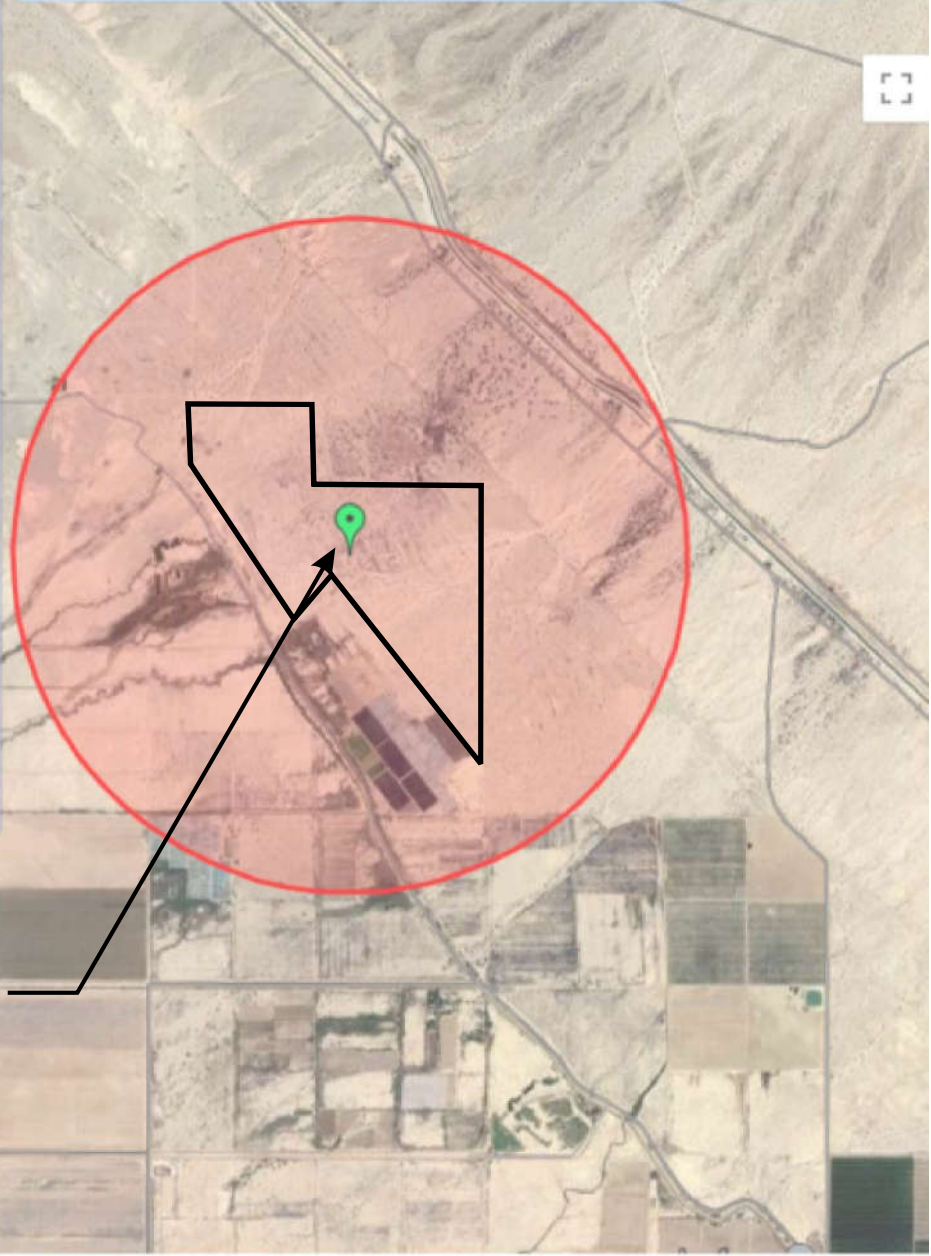

© 2022 Imagery © 2022, Landsat / Copernicus, Maxar Technologies, U.S. Geological Survey, USDA/FPAC/GEO 500 m [Report a map error](#)

SITES FOUND IN SEARCH RADIUS: 0 SITES LISTED [EXPORT THIS LIST TO EXCEL](#)

PROJECT NAME	STATUS	PROJECT TYPE	ADDRESS	CITY
--------------	--------	--------------	---------	------



LEGEND - CHOOSE MORE SITES

- LUST Cleanup Sites - REMOVE
- Cleanup Program Sites - REMOVE
- Military Cleanup Sites - REMOVE
- Military Privatized Sites - REMOVE
- Military UST Sites - REMOVE

Signifies a Closed Site

ACTIVE MAP COVERAGES:

- Military Bases - - REMOVE

SITES VISIBLE ON MAP - CHOOSE FIELDS

SITE NAME	STATUS

Map data ©2022 Imagery ©2022, Maxar Technologies, U.S. Geological Survey, USDA/FPA



Project No.: GS2219

Geotracker Map

Plate
6

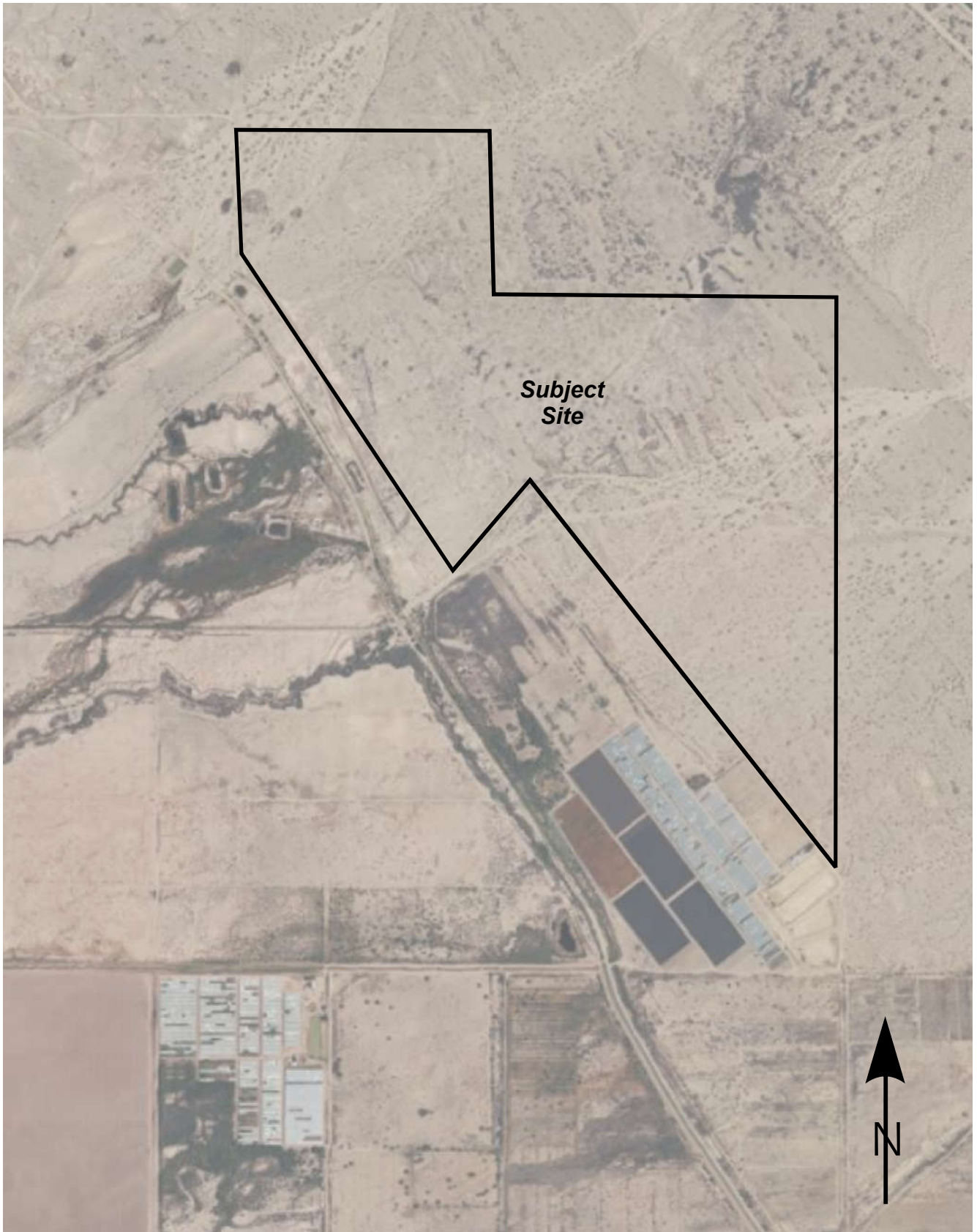

*Subject
Site*



APPENDIX H

Northstar 1 Solar Project
EHL Canal and Niland Lateral 6
Calipatria, CA 92233

Inquiry Number: 7022950.5
June 17, 2022

The EDR-City Directory Image Report

TABLE OF CONTENTS

SECTION

Executive Summary

Findings

City Directory Images

Thank you for your business.

Please contact EDR at 1-800-352-0050
with any questions or comments.

Disclaimer - Copyright and Trademark Notice

This Report contains certain information obtained from a variety of public and other sources reasonably available to Environmental Data Resources, Inc. It cannot be concluded from this Report that coverage information for the target and surrounding properties does not exist from other sources. **NO WARRANTY EXPRESSED OR IMPLIED, IS MADE WHATSOEVER IN CONNECTION WITH THIS REPORT. ENVIRONMENTAL DATA RESOURCES, INC. SPECIFICALLY DISCLAIMS THE MAKING OF ANY SUCH WARRANTIES, INCLUDING WITHOUT LIMITATION, MERCHANTABILITY OR FITNESS FOR A PARTICULAR USE OR PURPOSE. ALL RISK IS ASSUMED BY THE USER. IN NO EVENT SHALL ENVIRONMENTAL DATA RESOURCES, INC. BE LIABLE TO ANYONE, WHETHER ARISING OUT OF ERRORS OR OMISSIONS, NEGLIGENCE, ACCIDENT OR ANY OTHER CAUSE, FOR ANY LOSS OR DAMAGE, INCLUDING, WITHOUT LIMITATION, SPECIAL, INCIDENTAL, CONSEQUENTIAL, OR EXEMPLARY DAMAGES. ANY LIABILITY ON THE PART OF ENVIRONMENTAL DATA RESOURCES, INC. IS STRICTLY LIMITED TO A REFUND OF THE AMOUNT PAID FOR THIS REPORT.** Purchaser accepts this Report "AS IS". Any analyses, estimates, ratings, environmental risk levels or risk codes provided in this Report are provided for illustrative purposes only, and are not intended to provide, nor should they be interpreted as providing any facts regarding, or prediction or forecast of, any environmental risk for any property. Only a Phase I Environmental Site Assessment performed by an environmental professional can provide information regarding the environmental risk for any property. Additionally, the information provided in this Report is not to be construed as legal advice.

Copyright 2020 by Environmental Data Resources, Inc. All rights reserved. Reproduction in any media or format, in whole or in part, of any report or map of Environmental Data Resources, Inc. or its affiliates is prohibited without prior written permission.

EDR and its logos (including Sanborn and Sanborn Map) are trademarks of Environmental Data Resources, Inc. or its affiliates. All other trademarks used herein are the property of their respective owners.

EXECUTIVE SUMMARY

DESCRIPTION

Environmental Data Resources, Inc.'s (EDR) City Directory Report is a screening tool designed to assist environmental professionals in evaluating potential liability on a target property resulting from past activities. EDR's City Directory Report includes a search of available city directory data at 5 year intervals.

RECORD SOURCES

EDR's Digital Archive combines historical directory listings from sources such as Cole Information and Dun & Bradstreet. These standard sources of property information complement and enhance each other to provide a more comprehensive report.

EDR is licensed to reproduce certain City Directory works by the copyright holders of those works. The purchaser of this EDR City Directory Report may include it in report(s) delivered to a customer. Reproduction of City Directories without permission of the publisher or licensed vendor may be a violation of copyright.



RESEARCH SUMMARY

The following research sources were consulted in the preparation of this report. A check mark indicates where information was identified in the source and provided in this report.

<u>Year</u>	<u>Target Street</u>	<u>Cross Street</u>	<u>Source</u>
2014	<input type="checkbox"/>	<input checked="" type="checkbox"/>	EDR Digital Archive
2010	<input type="checkbox"/>	<input checked="" type="checkbox"/>	EDR Digital Archive
2005	<input type="checkbox"/>	<input checked="" type="checkbox"/>	EDR Digital Archive
2000	<input type="checkbox"/>	<input checked="" type="checkbox"/>	EDR Digital Archive
1995	<input type="checkbox"/>	<input checked="" type="checkbox"/>	EDR Digital Archive
1992	<input type="checkbox"/>	<input checked="" type="checkbox"/>	EDR Digital Archive
1988	<input type="checkbox"/>	<input checked="" type="checkbox"/>	Haines Criss-Cross Directory
1982	<input type="checkbox"/>	<input type="checkbox"/>	POLK DIRECTORY CO
1977	<input type="checkbox"/>	<input type="checkbox"/>	POLK DIRECTORY CO
1972	<input type="checkbox"/>	<input type="checkbox"/>	POLK DIRECTORY CO
1967	<input type="checkbox"/>	<input type="checkbox"/>	POLK DIRECTORY CO
1963	<input type="checkbox"/>	<input type="checkbox"/>	POLK DIRECTORY CO
1959	<input type="checkbox"/>	<input type="checkbox"/>	POLK DIRECTORY CO

FINDINGS

TARGET PROPERTY STREET

EHL Canal and Niland Lateral 6
Calipatria, CA 92233

No Addresses Found

FINDINGS

CROSS STREETS

<u>Year</u>	<u>CD Image</u>	<u>Source</u>
-------------	-----------------	---------------

ENGLISH RD

2014	pg. A1	EDR Digital Archive
2010	pg. A2	EDR Digital Archive
2005	pg. A3	EDR Digital Archive
2000	pg. A4	EDR Digital Archive
1995	pg. A5	EDR Digital Archive
1992	pg. A6	EDR Digital Archive

English Rd

1988	pg. A7	Haines Criss-Cross Directory	
1982	-	POLK DIRECTORY CO	Street not listed in Source
1977	-	POLK DIRECTORY CO	Street not listed in Source
1972	-	POLK DIRECTORY CO	Street not listed in Source
1967	-	POLK DIRECTORY CO	Street not listed in Source
1963	-	POLK DIRECTORY CO	Street not listed in Source
1959	-	POLK DIRECTORY CO	Street not listed in Source

City Directory Images

ENGLISH RD 2014

8704 AVILEZ, DAVID
8895 RENDON, NOE

ENGLISH RD 2010

7710 KOON, KENNETH J
8704 AVILEZ, DAVID
8895 RENDON, NOE

ENGLISH RD 2005

7710	KOON, KENNETH J
8225	LAWRENCE, CLIFFORD C
8400	FISHER, MICHAEL D
	FISHER, OPAL L
8895	RENDON, NOE

ENGLISH RD 2000

7710 KOON, KENNETH
8225 LAWRENCE, C C
8400 FISHER, BOB J
8503 HOLCOMB, MEL
8704 AVILES, ARMANDO A

ENGLISH RD 1995

7710	KOON, KENNETH
8225	LAWRENCE, C C
8370	PRATER, MELVIN E
8400	FISHBURN, BOB J
8495	VALLEY PROPERTIES INC
8503	HOLCOMB, MEL
8895	BALDIVISO, D

ENGLISH RD 1992

7710	KOON, KENNETH
8225	LAWRENCE, C C
8400	FISHER, BOB J
8495	VAL PRO PACKING SHD VALLEY PROP INC
8503	HOLCOMB, MEL
8795	SEVILLA, MARY L
8895	BALDIVISO, D

English Rd 1988

★ 22 BUS 65 RES

ENGLISH RD 92233 CALIPATRIA

90	6510	FLORES J	348-5387
90		FLORES Jose R	348-2345
84		FLORES M	348-5387
50	6603	QUARLES Tad R	348-2460
49		WITHERS W O	348-5136
11	6804	DURAN Ignacio	348-2744
79	★	0 BUS	8 RES

ENGLISH RD 92257 NILAND

54	7710	KOON Kenneth	348-0222
22	8225	LAWRENCE Clifford C	348-0666
22	8370	PRATER Melvin E	348-0150
98	8400B	FISHER Bob J	348-0559
98	8495	CRISTOBAL Jesus	348-0269
76		★VAL RPO PACKING SHD	348-0669
35		★VALLET PROPERTIES	348-0767
35	8704	AVILES Armando A	348-0272
94	8795	SEVILLA V O	348-0260
42	8895	ALGAR John	348-0743
62		NAVARRO Francisco	348-0333
62	★	2 BUS	9 RES
14			

ENZ RD 92250 HOLTVILLE

41	1076	ENZ Walter	358-2550
41			
65			
04			
67			

5 DD9 B8 ± ' =



780 N. 4th Street
El Centro, CA 92243
(760) 337-1100

**Phase I Environmental Site Assessment (ESA)
User Questionnaire**

- 1) **Environmental liens that are filed or recorded against the *property*.**
Did a search of *recorded land title records* (or judicial records where appropriate) identify any environmental liens filed or recorded against the *property* under federal, tribal, state, or local law?

None

- 2) **Activity and use limitations that are in place on the *property* or that have been filed or recorded against the *property*.**
Did a search of *recorded land title records* (or judicial records where appropriate) identify any AULs, such as *engineering controls*, land use restrictions or *institutional controls* that are in place at the *property* and/or have been filed or recorded against the *property* under federal, tribal, state or local law?

None

- 3) **Specialized knowledge or experience of the person seeking to qualify for the LLP.**
Do you have any specialized knowledge or experience related to the *property* or nearby properties? For example, are you involved in the same line of business as the current or former occupants of the *property* or an *adjoining property* so that you would have specialized knowledge of the chemicals and processes used by this type of business?

No

4) **Relationship of the purchase price to the fair market value of the *property* if it were not contaminated.**

Does the purchase price being paid for this *property* reasonable reflect the fair market value of the *property*? If you conclude that there is a difference, have you considered whether the lower purchase price is because contamination is known or believed to be present at the *property*?

Yes, market price was paid.

5) **Commonly known or *reasonably ascertainable* information about the *property*.**

Are you aware of commonly known or *reasonably ascertainable* information about the *property* that would help the *environmental professional* to identify conditions indicative of releases or threatened releases? For example,

- a. Do you know the past uses of the *property*?
We do not.
- b. Do you know of specific chemicals or oils that are present or once were present at the *property*?
We do not.
- c. Do you know of spills or other chemical releases that have taken place at the *property*?
We do not.
- d. Do you know of any environmental cleanups that have taken place at the *property*?
We do not.

6) **The degree of obviousness of the presence or likely presence of contamination at the *property*, and the ability to detect the contamination by appropriate investigation.**

Based on your knowledge and experience related to the *property* are there any *obvious* indicators that point to the presence or likely presence of releases at the *property*?

Not that we know of.

Additional Information

- 1) Reason why Phase I ESA is required:

Due Diligence _____

- 2) Type of Property:

Commercial
Industrial
Residential
Vacant/Undeveloped
Other _____

- Type of Transaction:

Purchase
Financing
Sale
Lease
Other _____

- 3) Complete and correct address for the property:

Vacant Land - APN# 003-110-005 & 007-000, Niland, CA

- 4) Are there any existing environmental report, documents, correspondence, etc. available for review?

Not that we are aware of.

User Name/Company: ZGlobal _____

Address:

604 Sutter Street, Suite 250
Folsom, CA 95630

User Signature: _____

Date: _____

Northstar 1 Solar Project
EHL Canal and Niland Lateral 6
Calipatria, CA 92233

Inquiry Number: 7022950.7
June 21, 2022

EDR Environmental Lien and AUL Search

EDR Environmental Lien and AUL Search

The EDR Environmental Lien and AUL Search Report provides results from a search of available current land title records for environmental cleanup liens and other activity and use limitations, such as engineering controls and institutional controls.

A network of professional, trained researchers, following established procedures, uses client supplied address information to:

- search for parcel information and/or legal description;
- search for ownership information;
- research official land title documents recorded at jurisdictional agencies such as recorders' offices, registries of deeds, county clerks' offices, etc.;
- access a copy of the deed;
- search for environmental encumbering instrument(s) associated with the deed;
- provide a copy of any environmental encumbrance(s) based upon a review of key words in the instrument(s) (title, parties involved, and description); and
- provide a copy of the deed or cite documents reviewed.

Thank you for your business.

Please contact EDR at 1-800-352-0050
with any questions or comments.

Disclaimer - Copyright and Trademark Notice

This Report contains certain information obtained from a variety of public and other sources reasonably available to Environmental Data Resources, Inc. It cannot be concluded from this Report that coverage information for the target and surrounding properties does not exist from other sources. **NO WARRANTY EXPRESSED OR IMPLIED, IS MADE WHATSOEVER IN CONNECTION WITH THIS REPORT. ENVIRONMENTAL DATA RESOURCES, INC. SPECIFICALLY DISCLAIMS THE MAKING OF ANY SUCH WARRANTIES, INCLUDING WITHOUT LIMITATION, MERCHANTABILITY OR FITNESS FOR A PARTICULAR USE OR PURPOSE. ALL RISK IS ASSUMED BY THE USER. IN NO EVENT SHALL ENVIRONMENTAL DATA RESOURCES, INC. BE LIABLE TO ANYONE, WHETHER ARISING OUT OF ERRORS OR OMISSIONS, NEGLIGENCE, ACCIDENT OR ANY OTHER CAUSE, FOR ANY LOSS OR DAMAGE, INCLUDING, WITHOUT LIMITATION, SPECIAL, INCIDENTAL, CONSEQUENTIAL, OR EXEMPLARY DAMAGES. ANY LIABILITY ON THE PART OF ENVIRONMENTAL DATA RESOURCES, INC. IS STRICTLY LIMITED TO A REFUND OF THE AMOUNT PAID FOR THIS REPORT.** Purchaser accepts this Report "AS IS". Any analyses, estimates, ratings, environmental risk levels or risk codes provided in this Report are provided for illustrative purposes only, and are not intended to provide, nor should they be interpreted as providing any facts regarding, or prediction or forecast of, any environmental risk for any property. Only a Phase I Environmental Site Assessment performed by an environmental professional can provide information regarding the environmental risk for any property. Additionally, the information provided in this Report is not to be construed as legal advice.

Copyright 2017 by Environmental Data Resources, Inc. All rights reserved. Reproduction in any media or format, in whole or in part, of any report or map of Environmental Data Resources, Inc. or its affiliates is prohibited without prior written permission.

EDR and its logos (including Sanborn and Sanborn Map) are trademarks of Environmental Data Resources, Inc. or its affiliates. All other trademarks used herein are the property of their respective owners.

EDR Environmental Lien and AUL Search

TARGET PROPERTY INFORMATION

ADDRESS

EHL Canal and Niland Lateral 6
Northstar 1 Solar Project
Calipatria, CA 92233

ENVIRONMENTAL LIEN

Environmental Lien: Found Not Found

OTHER ACTIVITY AND USE LIMITATIONS (AULs)

AULs: Found Not Found

RESEARCH SOURCE

Source 1:

Imperial Recorder
Imperial, CA

PROPERTY INFORMATION

Deed 1:

Type of Deed: deed
Title is vested in: Stavros Kondilis
Title received from: Lia Kondilis
Deed Dated: 2/9/2004
Deed Recorded: 11/18/2008
Book: NA
Page: na
Volume: na
Instrument: na
Docket: NA
Land Record Comments:
Miscellaneous Comments:

Legal Description: See Exhibit

Legal Current Owner: Stavros Kondilis

Parcel # / Property Identifier: 003-110-005

Comments: See Exhibit

Deed 2:

Type of Deed: deed
Title is vested in: Stavros Kondilis
Title received from: Lia Kondilis
Deed Dated: 2/16/2004
Deed Recorded: 11/18/2008
Book: NA
Page: na
Volume: na
Instrument: na
Docket: NA
Land Record Comments:
Miscellaneous Comments:

Legal Description: See Exhibit

Legal Current Owner: Stavros Kondilis

Parcel # / Property Identifier: 003-110-007

Comments: See Exhibit

Deed Exhibit 1

RECORDING REQUESTED BY

Recorded in Official Records, Imperial County

11/18/2008
10:23 AM
AG

AND WHEN RECORDED MAIL THIS DEED AND, UNLESS OTHERWISE SHOWN BELOW, MAIL TAX STATEMENTS TO:

Dolores Provencio
County Clerk / Recorder

P Public

NAME
STREET
ADDRESS
CITY,
STATE
ZIP

STAVROS KONDILIS
15005 PASO DEL SOL
DEL MAR, CA. 92014

Doc#: 2008-032880

Titles: 1 Pages: 2

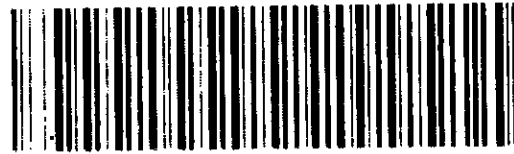

Fees 16.00
Taxes 0.00
Other 1.50
PAID \$17.50

Title Order No. _____ Escrow No. _____

SPACE ABOVE THIS LINE FOR RECORDER'S USE

QUITCLAIM DEED

DOCUMENTARY TRANSFER TAX \$0.00 INTERSPOUSAL

- computed on full value of property conveyed, or
- computed on full value less value of liens and encumbrances remaining at the time of sale.

Stavros Kondilis
Signature of Declarant or Agent Determining Tax.

Firm Name

(print or type name of grantor(s))

the undersigned grantor(s), for a valuable consideration, receipt of which is hereby acknowledged, do hereby remise, **LIA KONDILIS, SPOUSE OF GRANTEE** release and forever quitclaim to

STAVROS KONDILIS, A MARRIED MAN AS HIS SOLE & SEPARATE PROPERTY the following described real property in the City of

County of **IMPERIAL**, State of California:

LOT 5 & POR OF LOTS 6, 7, 8 & 13 SECTION 1 T10S R13E S.B.B.M. 109.18 AC
SEE EXHIBIT "A" ATTACHED HERE TO AND MADE A PART HEREOF.

Assessor's parcel No. 003-110-05

Executed on **FEBRUARY 9, 2004** at **COUNTY OF ORANGE, STATE OF CALIFORNIA**
(City and State)

Lia Kondilis
LIA KONDILIS

STATE OF CALIFORNIA

COUNTY OF San Diego } ss.

On this 27 day of Aug, in the year 2007, before me, the undersigned, a Notary Public in and for said State, personally appeared

Lia Kondilis

_____, personally known to me (or proved to me on the basis of satisfactory evidence) to be the person whose name _____ subscribed to the within instrument, and acknowledged to me that she executed it.

WITNESS my hand and official seal.

Ki Hoon Choi

Ki Hoon Choi, Notary Public in and for said State.

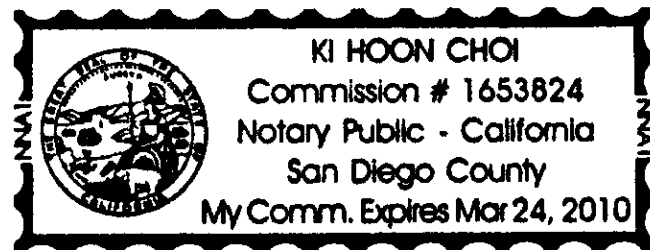

(This area for official notarial seal)

MAIL TAX STATEMENTS TO **STAVROS KONDILIS** **15005 PASO DEL SOL** **CA 92014**
NAME ADDRESS ZIP

EXHIBIT "A"

PARCEL 1: Lot 5 and that portion of Lot 6, Section 1, Township 10 South, Range 13 East, S.B.B.&M., according to the United States Official Plat of Re-Survey approved February 8, 1916, and on file in the United States Land Office at Los Angeles, California, lying East of the following described line: BEGINNING at a point 668.59 feet East of the Northwest corner of said Section 1; thence South $1^{\circ} 46' 20''$ West 999.02 feet; thence South $32^{\circ} 10' 40''$ East, to the South line of said lot 6. EXCEPTING THEREFROM any portion thereof included within the right of way for that certain Drain Ditch located along a portion of the Southwesterly line of said land, said Southwesterly line having a bearing of South $32^{\circ} 10' 40''$ East, a distance of 2940 feet.

PARCEL 2: Those portions of lots 7, 8 and 13, Section 1, Township 10 South, Range 13 East, S.B.B.&M., according to the United States Official Plat of Re-Survey approved February 8, 1916, and on file in the United States Land Office at Los Angeles, California, lying North and East of the following described line: BEGINNING at a point 668.59 feet East of the Northwest corner of said Section 1; thence South $1^{\circ} 46' 20''$ West 999.02 feet; thence South $32^{\circ} 10' 40''$ East 2940 feet; thence North $41^{\circ} 16'$ East, to the East line of said Lot 13, EXCEPTING THEREFROM any portion thereof included within the right of way for that certain ditch located along a portion of the Southwesterly line of said land, said Southwesterly line having a bearing of South $32^{\circ} 10' 40''$ East, a distance of 2940 feet.

Deed Exhibit 2

RECORDING REQUESTED BY

AND WHEN RECORDED MAIL THIS DEED AND, UNLESS OTHERWISE SHOWN BELOW, MAIL TAX STATEMENTS TO:

NAME: STAVROS KONDILIS
STREET ADDRESS: 15005 PASO DEL SOL
CITY, STATE, ZIP: DEL MAR, CA. 92014

Title Order No. _____ Escrow No. _____

Recorded in Official Records, Imperial County

11/18/2008
10:23 AM
AG

Dolores Provencio
County Clerk / Recorder

P Public

Doc#: 2008-032879

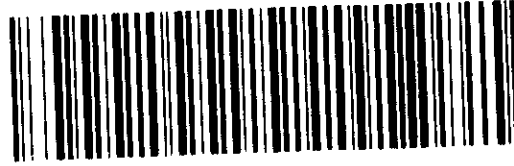

Titles: 1 Pages: 2
Fees: 16.00
Taxes: 0.00
Other: 1.50
PAID: \$17.50

SPACE ABOVE THIS LINE FOR RECORDER'S USE

QUITCLAIM DEED

DOCUMENTARY TRANSFER TAX \$0.00 INTERSPOUSAL

computed on full value of property conveyed, or

computed on full value less value of liens and encumbrances remaining at the time of sale.

Stavros Kondilis
Signature of Declarant or Agent Determining Tax. Firm Name

(print or type name of grantor(s))

the undersigned grantor(s), for a valuable consideration, receipt of which is hereby acknowledged, do hereby remise, **LIA KONDILIS, SPOUSE OF GRANTEE** release and forever quitclaim to

STAVROS KONDILIS, A MARRIED MAN AS HIS SOLE + SEPARATE PROPERTY the following described real property in the City of _____ County of **IMPERIAL**, State of California:

SEE EXHIBIT "A" ATTACHED HERETO AND MADE A PART HEREOF.

Assessor's parcel No. 003-110-07

Executed on FEBRUARY 18, 2004, at COUNTY OF ORANG, STATE OF CALIFORNIA

Lia Kondilis
LIA KONDILIS

STATE OF CALIFORNIA

COUNTY OF San Diego } ss.

On this 27 day of Aug, in the year 2007, before me, the undersigned, a Notary Public and for said State, personally appeared

Lia Kondilis

_____, personally known to me (or proved to me on the basis of satisfactory evidence) to be the person whose name _____ subscribed to the within instrument, and acknowledged to me that she executed it.

WITNESS my hand and official seal.

Ki Hoon Choi, Notary Public in and for said State.

(This area for official notarial seal)

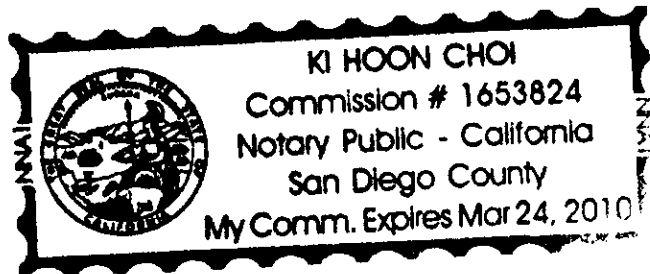

MAIL TAX

STATEMENTS TO STAVROS KONDILIS 15005 Paso Del Sol Ca 92014
NAME ADDRESS ZIP

EXHIBIT. "A"

PARCEL 1:

Lots 9 and 10, Section 1, Township 10 South, Range 13 East, S.B.M., in an unincorporated area of the County of Imperial, State of California, according to the Official Plat thereof.

PARCEL 2:

Lot 11, and those portions of Lot 12, and the Southeast Quarter of Section 1, Township 10 South, Range 13 East, S.B.M., in an unincorporated area of the County of Imperial State of California, according to the Official Plat thereof, lying North and East of the following described line:

Beginning at a point 668.59 feet East of the Northwest corner of said Section 1; thence South $1^{\circ}46'20''$ West, 999.02 feet; thence South $32^{\circ}10'40''$ East, 2940 feet; thence North $41^{\circ}16'$ East, 960.67 feet; thence South $38^{\circ}54'$ East, 3894.05 feet to the East line of said Section 1.

5 DD9 B8 4 >



**Steven K. Williams, PG, CEG
Consulting Geologist**

Education

M.S. Geology
University of Utah, 1993
B.S. Geology
University of Utah, 1989

Registration

Registered Geologist
Arizona 33759
California 6975
Certified Engineering Geologist
California 2261

Professional Experience

2000 – Present Senior Engineering Geologist
GS Lyon Consultants, Inc.
1994 - 2000 Staff Geologist
GS Lyon Consultants, Inc.
1994 Field Geologist
Bureau of Land Management
1991 - 1992 Exploration Geologist
Kennecott Corporation

Summary of Experience

Mr. Williams has 27 years of experience in performing Phase I Environmental Site Assessments throughout the Imperial and Coachella Valleys. The scope of work for these projects typically include a site reconnaissance, review of historical and government records pertaining to previous site uses, and preparation of a report identifying potential environmental risks.

Mr. Williams has also conducted Phase II Environmental Site Assessments for the evaluation of potential soil contamination by hydrocarbons, pesticides, and other hazardous materials. Mr. Williams has also conducted Preliminary Endangerment Assessments (PEAs) for school sites within the Imperial and Coachella Valleys.

Professional Affiliations

Geological Society of America, Member
Seismological Society of America, Member

Selected Project Experience

Residential

- El Centro Seniors Apartments, El Centro, CA
- Brawley Pioneers Apartments, Brawley, CA
- Calexico Family Apartments, Calexico, CA
- Bratton Subdivision, Imperial, CA
- Linda Vista Subdivision, El Centro, CA
- Mayfield Subdivision, Imperial, CA

Industrial

- Drew Solar Farm Phase I ESA, El Centro, CA
- Seville Solar Facility Phase I ESA, Imperial County, CA
- Dixieland East and West Solar Phase I ESA, Imperial County, CA
- Imperial Solar Energy Center South Phase I ESA, Imperial County, CA
- Imperial Solar Energy Center West Phase I ESA, Imperial County, CA
- Mt. Signal III Solar Facility Phase I ESA, Imperial County, CA
- Midway Solar Facility Phase I ESA, Calipatria, CA
- Iris Cluster Solar Facility Phase I ESA, Calexico, CA
- Vega Solar Facility Phase I ESA, Calexico, CA

Municipal/Commercial

- River Ranch Packing Facility, El Centro, CA
- Farm Fresh Cooling Facility, El Centro, CA
- El Centro Magistrate Court, El Centro, CA
- Bolthouse Farms Packing Facility, Holtville, CA
- Imperial Avenue Extension, El Centro, CA
- Taco Bell, Brawley, CA
- Taco Bell, Calexico, CA
- Calexico Crossroads Plaza, Calexico, CA
- Valley Plaza, El Centro, CA
- Gateway to the Americas Phase I ESA, Calexico, CA

School Sites

- Brawley Union High School, Brawley, CA
- La Paloma Middle School PEA, Brawley, CA
- Cross Elementary School Phase I ESA, Imperial, CA
- Oasis Elementary School PEA, Mecca, CA
- North Shore Elementary School Phase I ESA, Mecca, CA



**Peter LaBrucherie, PE
Consulting Engineer**

Education

B.S. Civil Engineering
California Polytechnic University, San Luis Obispo,
2011

M.S. Civil Engineering
California Polytechnic University, San Luis Obispo,
2012

Registration

Professional Engineer C84812, California

Professional Experience

2013 - Present Project Engineer
GS Lyon, Inc.
2012 - 2013 Project Engineer
BNBuilders.

Summary of Experience

Mr. LaBrucherie has 7 years of experience performing Phase I Environmental Site Assessments in Imperial County. The scope of work for these assessments typically includes site reconnaissance, review of historical and government records pertaining to previous site uses, and preparation of a report identifying potential environmental risks.

Selected Project Experience

Seville Solar Farm, Westmorland, CA

Conducted Phase I environmental site assessment for solar project located about 9 miles northwest of Westmorland, CA.

Drew Solar Farm, Imperial County, CA

Conducted Phase I environmental site assessment for 1000 acre solar project located about 9 miles southwest of El Centro, CA.

Clean Harbors Facility, Westmorland, CA

Conducted annual reports which included flood diversion, photo documentation and post closure for waste facility located about 5 miles west of Westmorland, CA.

Ching Properties, Brawley, CA

Conducted Phase I environmental site assessment for vacant property located in Brawley, CA.

Imperial Apartments, Imperial, CA

Conducted Phase I environmental site assessment for vacant property located in Imperial, CA. Property is being proposed for apartment complex.

1409 E. Alamo Road, Holtville, CA

Conducted Phase I environmental site assessment for property (mostly vacant with some unused shop buildings and abandoned residential home) located west of Holtville, CA.

BUSD School Site, Brawley, CA

Conducted Phase I environmental site assessment for school site proposal on a vacant property located in south Brawley, CA.

CR&R Direct Transfer, El Centro, CA

Conducted Phase I environmental site assessment for commercial property (large warehouse and office with large laydown area) located in El Centro, CA.

Villa Primavera Apartments, Calexico, CA

Conducted Phase I environmental site assessment for vacant property located in Calexico, CA.

Geotechnical Report

Proposed Northstar 1 Solar Project

APN 003-110-005 and -007

Niland, California

Prepared for:

Apex Energy Solutions, LLC

750 W. Main Street

El Centro, CA 92243



Prepared by:



Landmark Consultants, Inc.

780 N. 4th Street

El Centro, CA 92243

(760) 337-1100

November 2022

November 17, 2022

Mr. Ramon Gonzalez
Apex Energy Solutions, LLC
750 W. Main Street
El Centro, CA 92243

Geotechnical Report
Proposed NorthStar 1 Solar Project
(APN 003-110-005, and -007)
Niland, California
LCI Report No. LE22169

Dear Mr. Gonzalez:

This geotechnical report is provided for design and construction of the proposed 280-acre NorthStar 1 solar project located on the east side of the East Highline Canal north of the Niland Lateral 6 (APN 003-110-005 and -007) approximately 7 miles northwest of Niland, California. Our geotechnical exploration was conducted in response to your request for our services. The enclosed report describes our soil engineering site evaluation and presents our professional opinions regarding geotechnical conditions at the site to be considered in the design and construction of the project.

Based on the geotechnical conditions encountered at the points of exploration, the project site appears suitable for the proposed construction provided the professional opinions contained in this report are considered in the design and construction of this project.

We appreciate the opportunity to provide our findings and professional opinions regarding geotechnical conditions at the site. Please provide our office with a set of the foundation plans and civil plans for review to insure that the geotechnical site constraints have been included in the design documents. If you have any questions or comments regarding our findings, please call our office at (760) 370-3000.

Respectfully Submitted,
Landmark Consultants, Inc.

Julian R. Avalos, GE
Senior Geotechnical Engineer



Steven K. Williams, PG, CEG
Senior Engineering Geologist



Peter E. LaBrucherie, PE
Principal Engineer



TABLE OF CONTENTS

	Page
Section 1.....	1
INTRODUCTION	1
1.1 Project Description.....	1
1.2 Purpose and Scope of Work.....	1
1.3 Authorization	2
Section 2.....	3
METHODS OF INVESTIGATION	3
2.1 Field Exploration	3
2.2 Field Electrical Resistivity Testing.....	4
2.3 Thermal Resistivity Testing.....	5
2.4 Laboratory Testing.....	5
Section 3.....	6
DISCUSSION	6
3.1 Site Conditions.....	6
3.2 Geologic Setting.....	7
3.3 Subsurface Soil	7
3.4 Groundwater	8
3.5 Faulting	8
3.6 General Ground Motion Analysis.....	8
3.7 Seismic and Other Hazards.....	10
Section 4.....	12
DESIGN CRITERIA	12
4.1 Site Preparation.....	12
4.2 Foundations and Settlements	14
4.3 Drilled Piers and Driven Steel Piles.....	15
4.4 Slabs-On-Grade.....	18
4.5 Concrete Mixes and Corrosivity	19
4.6 Seismic Design.....	21
4.7 Pavements and Unpaved Roads.....	21
Section 5.....	24
LIMITATIONS AND ADDITIONAL SERVICES	24
5.1 Limitations	24
5.2 Plan Review	25
5.3 Additional Services.....	26

Appendices

APPENDIX A: Vicinity and Site Maps

APPENDIX B: Subsurface Soil Logs and Soil Key

APPENDIX C: Laboratory Test Results

APPENDIX D: Pipe Bedding and Trench Backfill Recommendations

APPENDIX E: Electrical and Thermal Resistivity

APPENDIX F: References

EXECUTIVE SUMMARY

This executive summary presents *selected* elements of our findings and professional opinions. This summary *may not* present all details needed for the proper application of our findings and professional opinions. Our findings, professional opinions, and application options are *best related through reading the full report*, and are best evaluated with the active participation of the engineer of record who developed them. The findings of this study are summarized below:

- The site soils consist of a surficial layer (1 to 5 feet) of sand/silty sand (SP/SM) overlying very stiff to hard clay soils (CL-CH) of medium to high expansion (EI = 70 to 130).
- The evaluation for the potential for liquefaction induced settlements at the site is not included in the scope of work for this project.
- The native clay soils are aggressive to concrete and steel. Concrete mixes for concrete placed in contact with native soils shall have a maximum water cement ratio of 0.50 and a minimum compressive strength of 4,000 psi (minimum of 6 sacks Type V cement per cubic yard). Bare steel in contact with native soil will require protective coatings to mitigate corrosion.
- All reinforcing bars, anchor bolts and hold down bolts shall have a minimum concrete cover of 3.0 inches unless epoxy coated (ASTM D3963/A934). Hold-down straps are not allowed at foundation perimeters. No pressurized water lines are allowed below or within foundations.
- Pavement structural sections should be designed with an R-value of 5 for native clays or 40 for the native sandy soils.
- All-weather accessways should consist of a minimum of 6 inches of Caltrans Class 2 aggregate base material placed over 12 inches of compacted native sands (95%). Cement stabilization or polymer modified soil is an alternative for internal roads stabilization within this project due to the existing subgrade composition of fine to medium grained sands.

Section 1

INTRODUCTION

1.1 Project Description

This report presents the findings of our geotechnical exploration and soil testing for the proposed NorthStar 1 solar project located on the east side of the East Highline Canal north of the Niland Lateral 6 (APN 003-110-005 and -007) approximately 7 miles northwest of Niland, California (See Vicinity Map, Plate A-1). The proposed project will consist of approximately 280 acres of PV solar panels mounted on steel racks supported by short piers, shallow driven steel posts or shallow spread footings. Also, the proposed solar energy facility will have ground mounted or pier supported inverter stations. The photovoltaic modules will be ground mounted on single-axis trackers or fixed-tilt frames. A grading plan for the proposed development was not made available to us at the time that this report was prepared.

Information about O&M building, control rooms, electrical substation, gen-tie line and/or battery storage structures was not provided at the time that this report was prepared. If mentioned structures are planned to be part of this project additional subsurface exploration may be required. Site development will include site grading, solar panel installation, underground utility installation, substation construction, and site fence construction.

1.2 Purpose and Scope of Work

The purpose of this geotechnical study was to investigate the subsurface soil at selected locations within the site for evaluation of physical/engineering properties and liquefaction potential during seismic events. Professional opinions were developed from field and laboratory test data and are provided in this report regarding geotechnical conditions at this site and the effect on design and construction. The scope of our services consisted of the following:

- ▶ Field exploration and in-situ testing of the site soils at selected locations and depths.
- ▶ Laboratory testing for physical and/or chemical properties of selected samples.
- ▶ Review of the available literature and publications pertaining to local geology, faulting, and seismicity.
- ▶ Engineering analysis and evaluation of the data collected.
- ▶ Preparation of this report presenting our findings and professional opinions regarding the geotechnical aspects of project design and construction.

This report addresses the following geotechnical parameters:

- ▶ Subsurface soil and groundwater conditions
- ▶ Site geology, regional faulting and seismicity, near source factors, and site seismic accelerations
- ▶ Expansive soil and methods of mitigation
- ▶ Aggressive soil conditions to metals and concrete

Professional opinions with regard to the above parameters are provided for the following:

- ▶ Site grading and earthwork
- ▶ Building pad and foundation subgrade preparation
- ▶ Allowable soil bearing pressures and expected settlements
- ▶ Concrete slabs-on-grade
- ▶ Typical capacities for drilled piers and driven steel piles
- ▶ Excavation conditions and buried utility installations
- ▶ Mitigation of the potential effects of salt concentrations in native soil to concrete mixes and steel reinforcement
- ▶ Seismic design parameters

Our scope of work for this report did not include an evaluation of the site for liquefaction during earthquakes or for the presence of environmentally hazardous materials or conditions, storm water infiltration, on-site wastewater percolation rates, groundwater mounding, or landscape suitability of the soil.

1.3 Authorization

Mr. Ziad Alaywan, President of Apex Energy Solutions, LLC provided authorization by written agreement to proceed with our work on August 8, 2022. We conducted our work in general accordance with our written proposal dated June 28, 2022.

Section 2

METHODS OF INVESTIGATION**2.1 Field Exploration**

Subsurface exploration was performed on August 31, 2022 by using a backhoe to excavate seven (7) test pits to an approximate depth of 7 feet below the existing ground surface. The test pit locations are shown on the Site and Exploration Plan (Plate A-2). Bulk samples were obtained at selected depths in the test pits. A nuclear densometer (ASTM D6938) was used to evaluate in-situ densities and natural moisture content at selected depths in the upper 7 feet of the backhoe pits. Pocket penetrometer readings were also obtained to evaluate the stiffness of cohesive soil encountered.

After logging and sampling the soil, the exploratory test pits were backfilled with the excavated material. The backfill was loosely placed and was not compacted to the requirements specified for engineered fill. The backhoe pits shall be located during rough grading of the site to properly recompact the backfill.

Additional subsurface exploration was performed on October 12, 2022 using 2R Drilling of Ontario, California to advance four (4) borings to depths of 21.5 feet below existing ground surface. The borings were advanced with a track-mounted, CME 75 drill rig using 8-inch diameter, hollow-stem, continuous-flight augers. The approximate boring locations were established in the field and plotted on the site map by sighting to discernible site features. The boring locations are shown on the Site and Exploration Plan (Plate A-2).

A professional engineer observed the drilling operations and maintained logs of the soil encountered with sampling depths. Soils were classified during drilling according to the Unified Soil Classification System using the visual-manual procedure in accordance with ASTM D2488. Relatively undisturbed and bulk samples of the subsurface materials were obtained at selected intervals. The relatively undisturbed soil samples were retrieved using a 2-inch outside diameter (OD) split-spoon sampler or a 3-inch OD Modified California Split-Barrel (ring) sampler lined with 6-inch stainless-steel sleeves. In addition, Standard Penetration Tests (SPT) were performed in accordance with ASTM D1586 and ASTM D6066. The samples were obtained by driving the samplers ahead of the auger tip at selected depths using a 140-pound CME automatic hammer with a 30-inch drop.

The number of blows required to drive the samplers the last 12 inches of an 18-inch drive depth into the soil is recorded on the boring logs as “blows per foot”. Blow counts (N values) reported on the boring logs represent the field blow counts. No corrections have been applied to the blow counts shown on the boring logs for effects of overburden pressure, automatic hammer drive energy, drill rod lengths, liners, and sampler diameter. Pocket penetrometer readings were also obtained to evaluate the stiffness of cohesive soils retrieved from sampler barrels.

After logging and sampling the soil, the exploratory borings were backfilled with the excavated material. The backfill was loosely placed and was not compacted to the requirements specified for engineered fill.

A professional engineer and soil technician maintained logs of the borings and test pits during exploration. The logs were edited in final form after a review of retrieved samples and the field and laboratory data. The test pit logs are presented on Plates B-1 through B-11 in Appendix B. Soils encountered in the test pits were classified according to the Unified Soil Classification System using the visual-manual procedure in accordance with ASTM D2488. A key to the test pit logs is presented on Plate B-12. The stratification lines shown on the subsurface logs represent the approximate boundaries between the various strata. However, the transition from one stratum to another may be gradual over some range of depth.

2.2 Field Electrical Resistivity Testing

Wenner 4-pin field resistivity testing was conducted by RF Yeager Engineering of Lakeside, California under sub-contract to Landmark at three (3) locations within the proposed solar array site in accordance with ASTM G57 standards. Tests were conducted with both North-South and East-West pin orientations. The tests were conducted at pin spacings of 2.5, 5, 10, 15, 20 and 40 feet. Additionally, near surface soil samples (upper 3 feet) were obtained for laboratory soil corrosivity testing at the select location. The results of the electrical resistivity and soil corrosivity testing are presented in Appendix E.

2.3 Insitu Thermal Resistivity Testing

Insitu soil thermal resistivity testing was conducted by RF Yeager Engineering at three (3) locations within the project site. The tests were conducted at the locations shown on Figure 1 in Appendix E. The testing was conducted in accordance with ASTM D5334. Near surface soil samples were obtained from test pits T-1, T-2 and T-3 as shown on Figure 1 in Appendix E.

2.4 Laboratory Testing

Laboratory tests were conducted on selected bulk (auger cuttings) and relatively undisturbed soil samples obtained from the soil borings to aid in classification and evaluation of selected engineering properties of the site soils. The tests were conducted in general conformance to the procedures of the American Society for Testing and Materials (ASTM) or other standardized methods as referenced below.

The laboratory testing program consisted of the following tests:

- ▶ Plasticity Index (ASTM D4318)
- ▶ Particle Size Analyses (ASTM D422)
- ▶ Unit Dry Densities (ASTM D2937)
- ▶ Moisture Contents (ASTM D2216)
- ▶ Moisture-Density Relationship (ASTM D1557)
- ▶ Unconfined Compression (ASTM D2166)
- ▶ Direct Shear (ASTM D3080)

The laboratory test results are presented on the subsurface logs (Appendix B) and in Appendix C.

Engineering parameters of soil strength, compressibility and relative density utilized for developing design criteria provided within this report were obtained from the field and laboratory testing program.

Section 3

DISCUSSION**3.1 Site Conditions**

The proposed NorthStar 1 solar project located on the east side of the East Highline Canal north of the Niland Lateral 6 (APN 003-110-005 and -007) approximately 7 miles northwest of Niland, California. The project site is irregular in plan view and slopes (about 2¼%) to the southwest. The site consists of approximately 280 acres of vacant desert land. The project site is crossed (northeast to southwest) by numerous dry wash beds. Several dirt trails cross the site. The subject property is covered with scattered dry desert brush. An existing power line is located along the northern boundary of the subject property. ***The project site contains two dry wash beds (Flood Zone A) crossing the site that originate from the Coachella Canal siphons (Plate A-6). The project site improvements should be protected from flooding; and in addition, a site specific flood study may be required by Imperial County.***

Adjacent properties are flat-lying and are approximately at the same elevation with this site. The subject property is located at the transition between vacant desert land to the east and north and agricultural lands to the south and west. A gravel borrow pit is located adjacent to the northwest corner of the subject property. A farming operation with temporary greenhouses is located adjacent to the southwest boundary of the subject property. The Coachella Canal is located to the east of the subject site with the active United States Department of Defense Chocolate Mountain Aerial Gunnery Range located east of the canal.

The project site lies at an elevation of approximately 20 feet above to 60 feet below mean sea level (MSL) (El. 940 to 1020 local datum) in the Imperial Valley region of the California low desert. The surrounding properties lie on terrain which is planar, sloping downward to the northeast, at the northwestern fringe of a large agricultural valley, which was previously an ancient lake bed covered with fresh water to an elevation of 43± feet above MSL. The ancient shoreline is located at the northeast corner of the site. Annual rainfall in this arid region is less than 3 inches per year with four months of average summertime temperatures above 100 °F. Winter temperatures are mild, seldom reaching freezing.

3.2 Geologic Setting

The project site is located in the Salton Trough region of the Colorado Desert physiographic province of southeastern California. The Salton Trough is a topographic and geologic structural depression resulting extending from the San Geronio Pass to the Gulf of California (Norris & Webb, 1990). The Salton Trough is bounded on the northeast by the San Andreas Fault and Chocolate Mountains and the southwest by the Peninsular Range and faults of the San Jacinto Fault Zone. The Salton Trough represents the northward extension of the Gulf of California, containing both marine and non-marine sediments deposited since the Miocene Epoch (Morton, 1977). Tectonic activity that formed the trough continues at a high rate as evidenced by deformed young sedimentary deposits and high levels of seismicity. Figure 1 shows the location of the site in relation to regional faults and physiographic features.

The Imperial Valley is directly underlain by lacustrine deposits, which consist of interbedded lenticular and tabular silt, sand, and clay. The Late Pleistocene to Holocene (present) lake deposits are probably less than 100 feet thick and derived from periodic flooding of the Colorado River which intermittently formed a fresh water lake (Lake Cahuilla). Older deposits consist of Miocene to Pleistocene non-marine and marine sediments deposited during intrusions of the Gulf of California. Basement rock consisting of Mesozoic granite and Paleozoic metamorphic rocks are estimated to exist at depths between 15,000 - 20,000 feet. The project site lies at the base of the piedmont slope of the Chocolate Mountains with alluvial fan spreads and sand washes.

3.3 Subsurface Soil

Subsurface soils encountered during the field exploration conducted on August 31 and October 12, 2022 consist of surficial sands/silty sands (SP/SM) and silty clays to a depth of 1 to 4 feet below ground surface. The surficial sands overlie very stiff to hard silty clay/clay soils (CL-CH) to a depth of 21.5 feet, the maximum depth of exploration. The subsurface logs (Plates B-1 through 11) depict the stratigraphic relationships of the subsurface soil encountered at the points of exploration. Variations in subsurface stratigraphy may occur between the points of exploration. The stratification lines shown on the subsurface log represent the approximate boundaries between the various strata. However, the transition from one stratum to another may be gradual over some range of depth.

3.4 Groundwater

Groundwater was not encountered in the borings and test pits at the time of exploration.

3.5 Faulting

The project site is located in the seismically active Imperial Valley of southern California with numerous mapped faults traversing the region including the San Andreas, San Jacinto, and Elsinore Fault Zones in southern California. The Imperial fault represents a transition from the more continuous San Andreas fault to a more nearly echelon pattern characteristic of the faults under the Gulf of California (USGS, 1990). We have performed a computer-aided search of known faults or seismic zones that lie within a 46 mile radius of the project site (Table 1).

A fault map illustrating known active faults relative to the site is presented on Figure 1, *Regional Fault Map*. Figure 2 shows the project site in relation to local faults. The criterion for fault classification adopted by the California Geological Survey defines Earthquake Fault Zones along Holocene-active or pre-Holocene faults (CGS, 2022b). Earthquake Fault Zones are regulatory zones that address the hazard of surface fault rupture. A Holocene-active fault is one that has ruptured during Holocene time (within the last 11,700 years). A pre-Holocene fault is a fault that has not ruptured in the last 11,700 years. Pre-Holocene faults may still be capable of surface rupture in the future, but are not regulated by the A-P act.

Review of the current Earthquake Fault Zone maps (CGS, 2022a) indicates that the nearest zoned fault is the San Andreas fault located approximately 10.2 miles northwest of the project site.

3.6 General Ground Motion Analysis

The project site is considered likely to be subjected to moderate to strong ground motion from earthquakes in the region. Ground motions are dependent primarily on the earthquake magnitude and distance to the seismogenic (rupture) zone. Acceleration magnitudes also are dependent upon attenuation by rock and soil deposits, direction of rupture and type of fault; therefore, ground motions may vary considerably in the same general area.

2019 CBC General Ground Motion Parameters: The California Building Code (CBC) requires that a site-specific ground motion hazard analysis be performed in accordance with ASCE 7-16 Section 11.4.8 (ASCE, 2016) for structures on Site Class D and E sites with S_1 greater than or equal to 0.2 and Site Class E sites with S_s greater than or equal to 1.0 (CBC, 2019). **This project site has been classified as Site Class D and has a S_1 value of 0.567, which would require a site-specific ground motion hazard analysis.** However, ASCE 7-16 Section 11.4.8 provides three exceptions which permit the use of conservative values of design parameters for certain conditions for Site Class D and E sites in lieu of a site specific hazard analysis. The exceptions are:

- Exception 1: Structures on Site Class E sites with S_s greater than or equal to 1.0, provided the site coefficient F_a is taken as equal to that of Site Class C.
- Exception 2: Structures on Site Class D sites with S_1 greater than or equal to 0.2, provided the value of the seismic response coefficient C_s is determined by Equations 12.8-2 for values of $T \leq 1.5T_s$ and taken as equal to 1.5 times the value computed in accordance with either Equation 12.8-3 for $T_L \geq T > 1.5T_s$ or Equation 12.8-4 for $T > T_L$.
- Exception 3: Structures on Site Class E sites with S_1 greater than or equal to 0.2, provided that T is less than or equal to T_s and the equivalent static force procedure is used for design.

Based on our understanding of the proposed development, the seismic design parameters presented in Table 2 were calculated assuming that one of the exceptions listed above applies to the proposed structures at this site. **However, the structural engineer should verify that one of the exceptions is applicable to the proposed structures.** If none of the exceptions apply, our office should be consulted to perform a site-specific ground motion hazard analysis.

The 2019 CBC general ground motion parameters are based on the Risk-Targeted Maximum Considered Earthquake (MCE_R). The Structural Engineers Association of California (SEAOC) and Office of Statewide Health Planning and Development (OSHPD) Seismic Design Maps Web Application (SEAOC, 2022) was used to obtain the site coefficients and adjusted maximum considered earthquake spectral response acceleration parameters. Design spectral response acceleration parameters are defined as the earthquake ground motions that are two-thirds (2/3) of the corresponding MCE_R ground motions. The Maximum Considered Earthquake Geometric Mean (MCE_G) peak ground acceleration adjusted for soil site class effects (PGA_M) value to be used for liquefaction and seismic settlement analysis in accordance with 2019 CBC Section 1803.5.12 ($PGA_M = F_{PGA} * PGA$) is estimated at 0.59g for the project site. **Design earthquake ground motion parameters are provided in Table 2.**

3.7 Seismic and Other Hazards

- ▶ **Groundshaking.** The primary seismic hazard at the project site is the potential for strong groundshaking during earthquakes along the Elmore Ranch, Hot Springs and San Andreas faults.
- ▶ **Surface Rupture.** The California Geological Survey (2016) has established Earthquake Fault Zones in accordance with the 1972 Alquist-Priolo Earthquake Fault Zone Act. The Earthquake Fault Zones consists of boundary zones surrounding well defined, active faults or fault segments. The project site does not lie within an A-P Earthquake Fault Zone. There is a moderate potential for future surface fault rupture from Holocene-active faults crossing the project site.
- ▶ **Liquefaction and lateral spreading.** Liquefaction is unlikely to be a potential hazard at the site due to the lack of saturated granular soil (clay soils predominate) and the estimated depth to groundwater (greater than 50 feet). *The evaluation for the potential for liquefaction induced settlements at the site is not included in the scope of work for this project.*

Other Potential Geologic Hazards.

- ▶ **Landsliding.** The hazard of landsliding is unlikely due to the regional planar topography. No ancient landslides are shown on geologic maps, aerial photographs and topographic maps of the region and no indications of landslides were observed during our site investigation.
- ▶ **Volcanic hazards.** The site is not located proximal to any known volcanically active area and the risk of volcanic hazards is considered low. Obsidian Butte and Red Hill, located at the south end of the Salton Sea approximately 7 miles south to southwest of the project site, are small remnants of volcanic domes. The domes erupted about 1,800 to 2,500 years ago (Wright et al, 2015). The subsurface brine fluids around the domes have a high heat flow and are currently being utilized to produce geothermal energy.
- ▶ **Tsunamis and seiches.** Tsunamis are giant ocean waves created by strong underwater seismic events, asteroid impact, or large landslides. Seiches are large waves generated in enclosed bodies of water in response to strong ground shaking. The site is not located near any large bodies of water, so the threat of tsunami, seiches, or other seismically-induced flooding is considered unlikely.

- ▶ **Flooding.** Based on our review of FEMA (2008) FIRM Panel 06025C0425C which encompasses the project site, the project site is located in Flood Zone X with dry wash beds originating at the Coachella Canal siphons and crossing the site as Flood Zone A. Flood Zone X are areas determined to be outside the 0.2% annual chance (500-year) floodplain. Flood Zone A, an area within a special flood hazard area subject to inundation by the 1% annual chance (100-year) of flood. No base flood elevations have been determined.
- ▶ **Collapsible soils.** Collapsible soil generally consists of dry, loose, low-density material that have the potential collapse and compact (decrease in volume) when subjected to the addition of water or excessive loading. Soils found to be most susceptible to collapse include loess (fine grained wind-blown soils), young alluvium fan deposits in semi-arid to arid climates, debris flow deposits and residual soil deposits. Due to the cohesive nature of the subsurface soils, the potential for hydro-collapse of the subsurface soils at this project site is considered very low.
- ▶ **Expansive soils.** In general, much of the subsurface soils in the Imperial Valley consist of silty clays and clays which are moderate to highly expansive. The expansive soil conditions are discussed in more detail in Section 3.3.

Section 4

DESIGN CRITERIA**4.1 Site Preparation**

Clearing and Grubbing: All debris or vegetation including grass and weeds on the site at the time of construction should be removed from the construction area. Root balls should be completely excavated. Organic strippings should be stockpiled and not used as engineered fill.

Grading: Prior to general site grading, the backhoe test pit locations shall be identified and the loose backfill compacted to a depth of 7 feet. In areas designated for fill, the surface 12 inches of native soil shall be scarified uniformly moisture conditioned to within 2% of optimum and compacted to at least 90% of ASTM D1557 maximum density.

Onsite native soils used for fill should be placed in lifts no greater than 8 inches in loose thickness and compacted to a minimum of 90% of ASTM D1557 maximum dry density at optimum moisture $\pm 2\%$.

Embankment construction: All areas to receive new fill for the embankments should be stripped of all vegetation. The surface 12 inches of native soil shall be uniformly moisture conditioned to $\pm 2\%$ of optimum moisture by discing and compacted in 6-inch maximum lifts to a minimum of 90% of ASTM D1557 maximum density.

The embankment slopes may be constructed no steeper than 3:1 (unless slope protection is provided) with a minimum crown width of 15 feet. Embankments should be overbuilt by 6 inches and subsequently cut to the plan line and grade to remove loose material along the slope faces.

Granular Building Pad Preparation: The existing soils within building pad/foundation areas should be overexcavated to a minimum depth of 36 inches below the existing natural surface grade or building pad grade (whichever is greater) and should extend at least five (5) feet beyond all exterior wall/column lines (including concreted areas adjacent to the building). Exposed subgrade should be scarified to a depth of 8 inches, uniformly moisture conditioned to 2% below to 2% above optimum (sands), 5 to 10% above optimum (clays) and recompact to a minimum of 90% (sands), between 85 to 90% (clays) of the maximum density determined in accordance with ASTM D1557 methods.

The native sand and silty sand soil is suitable for use as engineered fill provided it is free from concentrations of organic matter or other deleterious material. The fill soil should be uniformly moisture conditioned by discing and watering to the limits specified above, placed in maximum 8-inch lifts (loose), and compacted to the limits specified above. ***Clay soil, if encountered, should not be incorporated into any engineered building pads.***

If imported soils are required, these should meet the USCS classifications of ML (non-plastic), SM, SP-SM, or SW-SM with a maximum rock size of 3 inches and no less than 5% passing the No. 200 sieve. The geotechnical engineer should approve imported fill soil sources before hauling material to the site. Imported fill should be placed in lifts no greater than 8 inches in loose thickness and compacted to a minimum of 90% of ASTM D1557 maximum dry density at optimum moisture $\pm 2\%$.

Utility Trench Backfill: On-site soil free of debris, vegetation, and other deleterious matter may be suitable for use as utility trench backfill above pipezone, but may be difficult to uniformly maintain at specified moistures and compact to the specified densities. Native backfill should only be placed and compacted after encapsulating buried pipes or direct burial cables with suitable granular bedding materials and pipe envelope material.

Backfill soil of utility trenches within paved areas should be placed in layers not more than 6 inches in thickness and mechanically compacted to a minimum of 90% of the ASTM D1557 maximum dry density.

Observation and Density Testing: All site preparation and fill placement should be observed and tested by a representative of a qualified geotechnical engineering firm. The geotechnical firm that provides observation and testing during construction shall assume the responsibility of "geotechnical engineer of record" and, as such, shall perform additional tests and investigation as necessary to satisfy themselves as to the site conditions and the recommendations for site development.

4.2 Foundations and Settlements

Shallow spread or continuous conventional footings are suitable to support the building and site structures within the electrical substation. The foundations may be designed using an allowable soil bearing pressure of 2,000 psf when foundations are supported on imported or native compacted sands (extending a minimum of 1.5 feet below footings). The allowable soil pressure may be increased by 20% for each foot of embedment depth in excess of 18 inches and by one-third for short term loads induced by winds or seismic events. The maximum basic allowable soil pressure at increased embedment depths shall not exceed 3,500 psf.

Resistance to horizontal loads will be developed by passive earth pressure on the sides of footings and frictional resistance developed along the bases of footings and concrete slabs. Passive resistance to lateral earth pressure may be calculated using an equivalent fluid pressure of 300 pcf to resist lateral loadings. The top one foot of embedment should not be considered in computing passive resistance unless the adjacent area is confined by a slab or pavement. An allowable friction coefficient of 0.35 may also be used at the base of the footings to resist lateral loading.

Perimeter footings should be embedded a minimum of 18 inches below the lowest adjacent final grade. Continuous wall footings should have a minimum width of 12 inches. Spread footings should have a minimum dimension of 24 inches and should be structurally tied to perimeter footings or grade beams. Recommended concrete reinforcement and sizing for all footings should be provided by the structural engineer.

Flat Plate Structural Mats: Structural concrete mat foundations may be designed using an allowable soil bearing pressure of 2,000 psf when the foundation is supported on minimum 18 inches of compacted sands. The allowable soil pressure may be increased by one-third for short term loads induced by winds or seismic events. Design criteria for mat foundations are provided below.

Structural mats may be designed for a modulus of subgrade reaction (K_s) of 175 pci when placed on 18 inches of compacted sands and 200 pci when placed on 6 inches of compacted Class 2 aggregate base. Resistance to horizontal loads will be developed by passive earth pressure on the sides of footings and frictional resistance developed along the bases of footings and concrete slabs. Passive resistance to lateral earth pressure may be calculated using an equivalent fluid pressure of 300 pcf to resist lateral loadings. The top one foot of embedment should not be considered in

computing passive resistance unless the adjacent area is confined by a slab or pavement. An allowable friction coefficient of 0.35 may also be used at the base of the footings to resist lateral loading.

Foundation movement under the estimated loadings are estimated to not exceed 1 inch with differential movement of about two-thirds of total movement for the loading assumptions stated above when the subgrade preparation guidelines given above are followed.

4.3 Drilled Piers and Driven Steel Piles

Drilled Piers: Individual short piers should be adequate to support solar panel frames, inverter frames, and security camera poles. Embedment depth for short piers to resist lateral loads where no lateral constraint at the ground surface is provided may be designed using the following formula per 2019 CBC Section 1807.3.2.1:

$$d = A/2 [1 + (1+4.36h/A)^{1/2}]$$

where:

$$A = 2.34P/S_1b$$

b = Pier diameter in feet

d = Embedment depth in feet (but not over 12 feet for purpose of computing lateral pressure)

h = Distance in feet from ground surface to point of application of “P”

P = Applied lateral force in pounds

S_1 = Allowable lateral soil bearing pressure (basic value of 150 psf/ft. Isolated piers such as solar panel short piers that are not adversely affected by a 0.5 inch motion at the ground surface due to short-term lateral loads are permitted to be designed using lateral soil bearing pressures equal to two times the provided value (300 psf/ft). This load increase should not be used for the security camera pole foundation designs.

The short pier foundations may be designed using an allowable soil bearing pressure of 2,000 psf and a cohesion of 150 psf for the native clay soil. The cohesion value shall be multiplied by the contact area, as limited by Section 1806.3 of the 2019 CBC. Uplift capacity may be defined as the sum of the frictional resistance of the soils against the concrete pile plus the weight of the pile as follows:

$$P_{all} = (KHT * P_o * \tan \delta * \pi * D * H) / FS + W_p,$$

Incorporating the soil conditions at the site and applying a Safety Factor of 3 it may be expressed as,

$$P_{all} = 16DH^2 + W_p$$

where:

P_{all} = Allowable Uplift Capacity in pounds

D = Diameter of the pile in feet

H = Depth of embedment below ground surface in feet (to a maximum of 14 feet)

W_p = Weight of the pile in pounds

Installation: Excavation for piers should be inspected by the geotechnical consultant. A tremie pipe should be used to pour concrete from the bottom up and to ensure less than five feet of free fall. Groundwater was not encountered in the borings (>21.5 feet bgs) during the time of exploration. The structural steel and concrete should be placed immediately after drilling. Prior to placing any structural steel or concrete, loose soil or slough material should be removed from the bottom of the drilled pier excavation.

Driven Steel Piles: The use of driven steel posts requires special provisions for corrosion protection due to the corrosive nature of the subsurface soils. Steel posts for PV panel mounting frames have been preliminary sized as W8x10 (frame and axle supports).

Vertical Capacity: Vertical capacity for the preliminary W8x10 steel post section is presented in Table 3. End bearing and skin friction parameters have been used to determine the allowable shaft capacity. The allowable capacities include a factor of safety of 2.5. The allowable vertical compression capacities may be increased by 33 percent to accommodate temporary loads from wind or seismic forces. The allowable vertical shaft capacities are based on the supporting capacity of the soil.

Lateral Capacity: The allowable lateral capacity for a W8x10 steel post section at 6, 8 and 10 feet embedment depths are given in Table 3. The allowable lateral capacity is based on a deflection of one-half inch at the top of the steel post section. If greater deflection can be tolerated, lateral load capacity can be increased directly in proportion to a maximum of one inch deflection. Axial and lateral loads were applied at 4.0 feet above ground surface.

Table 3: Allowable Capacities of Driven Steel Posts

Pile Type:	Driven W8x10		
	10 ft	12 ft	14 ft
Pile Length (ft):	10 ft	12 ft	14 ft
Specified Tip Depth (ft):	6 ft	8 ft	10 ft
Height Above Ground (ft):	4 ft	4 ft	4 ft
Allowable Axial Capacity (kips) – FS=2.5:	3.85	6.20	8.59
Allowable Uplift Capacity (kips) – FS=2.5:	3.74	6.12	8.52
Lateral Load – Free Head Condition (kips):	0.76	1.12	1.15
Top Deflection (in) – Free Head Condition	0.50	0.50	0.50
Maximum Moment from Lateral Load, Free Head Condition (ft-kips):	4.30	6.53	6.73
Depth of Maximum Moment (from Top of Post), Free Head (ft):	6.0	6.5	6.6

Recommendations for other post sections can be made available upon request.

Soil Parameters: Interpretive soil parameters of the subsoil for AllPile software are presented in the table below.

Table 4: Soil Strength Parameters for AllPile Program

Layer Type	Depth (ft)	Unit Weight (pcf)	Friction Angle (deg)	Cohesion (ksf)	Lateral Soil Modulus, k (pci) (*)	e50 or Dr
SP	0 to 3	115	34°	---	80.0	80
CH	3 to 15	125	---	1.50	0.70	500

(*) k value for static loading. For cycling loading, use 50% of listed value.

Settlement: Total settlements of less than ¼ inch, and differential movement of about two-thirds of total movement for single piles designed according to the preceding recommendations.

Axial Load Group Effect: Reduction in axial load capacity shall be considered necessary for group effect. The axial load capacity shall be reduced by an efficiency factor, η . Efficiency factor, η should be 0.65 for shafts with spacing center to center equal to 2.5 shaft diameters and increases linearly to 1.0 for shafts with center to center spacing equal to 6.0 shaft diameters or more. The factor of safety of the group is the same as that of individual shaft elements.

4.4 Slabs-On-Grade

Concrete slabs and flatwork placed on the native silty clay should be a minimum of 6 inches thick due to expansive soil conditions. Concrete floor slabs shall be monolithically placed with the footings (no cold joints). The concrete slabs should be underlain by a 10-mil polyethylene vapor retarder that works as a capillary break to reduce moisture migration into the slab section. The vapor retarder should be properly lapped and continuously sealed. The vapor retarder should be overlain by 2 inches of clean sand (Sand Equivalent SE>30). Concrete slabs may be placed without a sand cover directly over a 15-mil vapor retarder (Stego-Wrap or equivalent).

Concrete slab and flatwork reinforcement should consist of chaired rebar slab reinforcement (minimum of No. 4 bars at 18-inch centers, both horizontal directions) placed at slab mid-height to resist potential swell forces and cracking.

Slab thickness and steel reinforcement are minimums only and should be verified by the structural engineer/designer knowing the actual project loadings. All steel components of the foundation system should be protected from corrosion by maintaining a 3-inch minimum concrete cover of densely consolidated concrete at footings (by use of a vibrator). The construction joint between the foundation and any sidewalks placed adjacent to foundations should be sealed with a polyurethane based non-hardening sealant to prevent moisture migration between the joint. Epoxy coated embedded steel components or permanent waterproofing membranes placed at the exterior footing sidewall may also be used to mitigate the corrosion potential of concrete placed in contact with native soil.

Control joints should be provided in all concrete slabs-on-grade at a maximum spacing (in feet) of 2 to 3 times the slab thickness (in inches) as recommended by American Concrete Institute (ACI) guidelines. All joints should form approximately square patterns to reduce randomly oriented contraction cracks. Contraction joints in the slabs should be tooled at the time of the pour or sawcut ($\frac{1}{4}$ of slab depth) within 6 to 8 hours of concrete placement. Construction (cold) joints in foundations and area flatwork should either be thickened butt-joints with dowels or a thickened keyed-joint designed to resist vertical deflection at the joint. All joints in flatwork should be sealed to prevent moisture, vermin, or foreign material intrusion. Precautions should be taken to prevent curling of slabs in this arid desert region (refer to ACI guidelines).

All independent flatwork (housekeeping slabs) should be placed on a minimum of 2 inches of concrete sand or aggregate base, dowelled to the perimeter foundations where adjacent to the building and sloped 2% or more away from the building. A minimum of 24 inches of moisture conditioned (minimum of optimum) and 8 inches of compacted subgrade (90% min) should underlie all independent flatwork. All flatwork should be jointed in square patterns and at irregularities in shape at a maximum spacing of 10 feet or the least width of the sidewalk.

4.5 Concrete Mixes and Corrosivity

Selected chemical analyses for corrosivity were conducted on bulk samples of the near surface soil from the project site (Appendix E). The native soils were found to have S0 (low) levels of sulfate ion concentration (40 to 410 ppm). Sulfate ions in high concentrations can attack the cementitious material in concrete, causing weakening of the cement matrix and eventual deterioration by raveling.

The following table provides American Concrete Institute (ACI) recommended cement types, water-cement ratio and minimum compressive strengths for concrete in contact with soils:

Table 5. Concrete Mix Design Criteria due to Soluble Sulfate Exposure

Sulfate Exposure Class	Water-soluble Sulfate (SO ₄) in soil, ppm	Cement Type	Maximum Water-Cement Ratio by weight	Minimum Strength f'c (psi)
S0	0-1,000	–	–	–
S1	1,000-2,000	II	0.50	4,000
S2	2,000-20,000	V	0.45	4,500
S3	Over 20,000	V (plus Pozzolon)	0.45	4,500

Note: From ACI 318-14 Table 19.3.1.1 and Table 19.3.2.1

Due to the scattered silty clay surface soils a minimum of 6.0 sacks per cubic yard of concrete (4,000 psi) of Type V Portland Cement with a maximum water/cement ratio of 0.50 (by weight) should be used for concrete placed in contact with native soil on this project (sitework including sidewalks, driveways, housekeeping slabs and foundations). Admixtures may be required to allow placement of this low water/cement ratio concrete.

The native soil has low to very severe levels of chloride ion concentration (130 to 8,860 ppm). Chloride ions can cause corrosion of reinforcing steel, anchor bolts and other buried metallic conduits. Resistivity determinations on the soil indicate severe to very severe potential for metal loss because of electrochemical corrosion processes. Mitigation of the corrosion of steel can be achieved by using steel elements coated with epoxy corrosion inhibitors, asphaltic and epoxy coatings, cathodic protection or by zinc galvanizing.

Foundation designs shall provide a minimum concrete cover of three (3) inches around steel reinforcing or embedded components (anchor bolts, etc.) exposed to native soil or landscape water (to 18 inches above grade). If the 3-inch concrete edge distance cannot be achieved, all embedded steel components (anchor bolts, etc.) shall be epoxy dipped for corrosion protection or a corrosion inhibitor and a permanent waterproofing membrane shall be placed along the exterior face of the exterior footings. Additionally, the concrete should be thoroughly vibrated at footings during placement to decrease the permeability of the concrete.

4.6 Seismic Design

This site is located in the seismically active southern California area and the site structures are subject to strong ground shaking due to potential fault movements along the San Andreas Fault, Elmore Ranch Fault, and Hot Springs Fault. Engineered design and earthquake-resistant construction are the common solutions to increase safety and development of seismic areas. Designs should comply with the latest edition of the CBC for Site Class D using the seismic coefficients given in Section 3.4 of this report.

4.7 Pavements and Unpaved Roads

Pavements should be designed according to CALTRANS or other acceptable methods. Traffic indices were not provided by the project engineer or owner; therefore, we have provided structural sections for several traffic indices for comparative evaluation. The public agency or design engineer should decide the appropriate traffic index for the site. Maintenance of proper drainage is necessary to prolong the service life of the pavements.

Based on the current State of California CALTRANS method, an estimated R-value of 5 (for exposed clay soil) and 40 (for sand soils) and assumed traffic indices, the following tables provides our estimates for asphaltic concrete (AC) and Portland Cement Concrete (PCC) pavement sections.

Table 6. Pavement Structural Sections

R-Value of Subgrade Soil – 5 (est. clay soil)

Design Method - CALTRANS 2020

Traffic Index (assumed)	Flexible Pavements		Rigid (PCC) Pavements	
	Asphaltic Concrete Thickness (in.)	Aggregate Base Thickness (in.)	Concrete Thickness (in.)	Aggregate Base Thickness (in.)
4.0	3.0	6.5	5.0	6.0
5.0	3.0	10.0	5.5	6.0
6.0	4.0	11.5	6.0	8.0
6.5	4.0	14.0	7.0	8.0

R-Value of Subgrade Soil – 40 (est. sand soil)

Design Method - CALTRANS 2020

Traffic Index (assumed)	Flexible Pavements		Rigid (PCC) Pavements	
	Asphaltic Concrete Thickness (in.)	Aggregate Base Thickness (in.)	Concrete Thickness (in.)	Aggregate Base Thickness (in.)
4.0	3.0	4.0	5.0	4.0
5.0	3.0	4.0	5.5	4.0
6.0	3.0	6.0	6.0	4.0
6.5	3.0	8.0	7.0	6.0

Notes:

- 1) Asphaltic concrete shall be Caltrans, Type B, $\frac{3}{4}$ inch maximum ($\frac{1}{2}$ inch maximum for parking areas), medium grading with PG70-10 asphalt cement, compacted to a minimum of 95% of the Hveem density (CAL 366).
- 2) Aggregate base shall conform to Caltrans Class 2 ($\frac{3}{4}$ in. maximum), compacted to a minimum of 95% of ASTM D1557 maximum dry density.
- 3) Place pavements on 12 inches of moisture conditioned (minimum 4% above optimum if clays) native clay soil compacted to a minimum of 90% (95% if sand subgrade) of the maximum dry density determined by ASTM D1557.
- 4) Portland cement concrete for pavements should have Type V cement, a minimum compressive strength of 4,500 psi at 28 days, and a maximum water-cement ratio of 0.45.
- 5) Typical Street Classifications (Imperial County)

Parking Areas:	TI = 4.0
Cul-de-Sacs:	TI = 5.0
Local Streets:	TI = 6.0
Minor Collectors:	TI = 6.5

Unpaved Roads: Unpaved roads may be used for stabilized roadways. The unpaved roads should consist of 12 inches of native soils compacted to 95% of ASTM D1557 maximum density at a minimum of optimum moisture with a 6 inch layer of Class 2 aggregate base compacted to a minimum of 95% of ASTM D1557 maximum density placed over the compacted subgrade.

Cement stabilization is an alternative for internal roads stabilization within this project since the existing subgrade is comprised of fine to medium grained sands. An 80,000 lb. two-axle truck (fire truck) was considered for the subgrade soil stabilization recommendations. Soil-cement stabilization of the subgrade soils will result in a Gravel Factor for the treated depth, typically in the range of 1.2 to 1.5.

A minimum of 8 inches of cement-treated subgrade soil (estimated at 4% by weight) compacted to 95% minimum should yield a minimum Unconfined Compressive Strength of 300 psi. The cement application ratio should be confirmed through proper testing to obtain the minimum Unconfined Compressive Strength of 300 psi. The 80,000 lb. axle load will be adequately supported by the compacted soil-cement.

Section 5

LIMITATIONS AND ADDITIONAL SERVICES**5.1 Limitations**

The findings and professional opinions within this report are based on current information regarding the proposed 280-acre NorthStar 1 solar project located on the east side of the East Highline Canal north of the Niland Lateral 6 (APN 003-110-005 and -007) approximately 7 miles northwest of Niland, California. The conclusions and professional opinions of this report are invalid if:

- ▶ Structural loads change from those stated or the structures are relocated.
- ▶ The Additional Services section of this report is not followed.
- ▶ This report is used for adjacent or other property.
- ▶ Changes of grade or groundwater occur between the issuance of this report and construction other than those anticipated in this report.
- ▶ Any other change that materially alters the project from that proposed at the time this report was prepared.

This report was prepared according to the generally accepted *geotechnical engineering standards of practice* that existed in Imperial County at the time the report was prepared. No express or implied warranties are made in connection with our services.

Findings and professional opinions in this report are based on selected points of field exploration, geologic literature, limited laboratory testing, and our understanding of the proposed project. Our analysis of data and professional opinions presented herein are based on the assumption that soil conditions do not vary significantly from those found at specific exploratory locations. Variations in soil conditions can exist between and beyond the exploration points or groundwater elevations may change. The nature and extend of such variations may not become evident until, during or after construction. If variations are detected, we should immediately be notified as these conditions may require additional studies, consultation, and possible design revisions.

Environmental or hazardous materials evaluations were not performed by Landmark for this project. Landmark will assume no responsibility or liability whatsoever for any claim, damage, or injury which results from pre-existing hazardous materials being encountered or present on the project site, or from the discovery of such hazardous materials.

The client has responsibility to see that all parties to the project including designer, contractor, and subcontractor are made aware of this entire report within a reasonable time from its issuance. This report should be considered invalid for periods after two years from the date of report issuance without a review of the validity of the findings and professional opinions by our firm, because of potential changes in the Geotechnical Engineering Standards of Practice. This report is based upon government regulations in effect at the time of preparation of this report. Future changes or modifications to these regulations may require modification of this report. Land or facility use, on and off-site conditions, regulations, design criteria, procedures, or other factors may change over time, which may require additional work. Any party other than the client who wishes to use this report shall notify Landmark of such intended use. Based on the intended use of the report, Landmark may require that additional work be performed and that an updated report be issued. Non-compliance with any of these requirements by the client or anyone else will release Landmark from any liability resulting from the use of this report by any unauthorized party and client agrees to defend, indemnify, and hold Landmark harmless from any claim or liability associated with such unauthorized use or non-compliance.

This report contains information that may be useful in the preparation of contract specifications. However, the report is not worded in such a manner that we recommend its use as a construction specification document without proper modification. The use of information contained in this report for bidding purposes should be done at the contractor's option and risk.

5.2 Plan Review

Landmark Consultants, Inc. should be retained during development of design and construction documents to check that the geotechnical professional opinions are appropriate for the proposed project and that the geotechnical professional opinions are properly interpreted and incorporated into the documents. Landmark should have the opportunity to review the final design plans and specifications for the project prior to the issuance of such for bidding.

Governmental agencies may require review of the plans by the geotechnical engineer of record for compliance to the geotechnical report.

5.3 Additional Services

We recommend that Landmark Consultant be retained to provide the tests and observations services during construction. *The geotechnical engineering firm providing such tests and observations shall become the geotechnical engineer of record and assume responsibility for the project.*

Landmark Consultants, Inc. professional opinions for this site are, to a high degree, dependent upon appropriate quality control of subgrade preparation, fill placement, and foundation construction. Accordingly, the findings and professional opinions in this report are made contingent upon the opportunity for Landmark Consultants to observe grading operations and foundation excavations for the proposed construction.

If parties other than Landmark Consultants, Inc. are engaged to provide observation and testing services during construction, such parties must be notified that they will be required to assume complete responsibility as the geotechnical engineer of record for the geotechnical phase of the project by concurring with the professional opinions in this report and/or by providing alternative professional guidance.

Additional information concerning the scope and cost of these services can be obtained from our office.

TABLES

Table 1
Summary of Characteristics of Closest Known Active Faults

Fault Name	Approximate Distance (miles)	Approximate Distance (km)	Maximum Moment Magnitude (Mw)	Fault Length (km)	Slip Rate (mm/yr)
Hot Springs *	6.5	10.4			
Elmore Ranch	8.8	14.0	6.6	29 ± 3	1 ± 0.5
San Andreas - Coachella	10.2	16.4	7.2	96 ± 10	25 ± 5
Brawley *	25.9	41.5			
Imperial	26.1	41.8	7	62 ± 6	20 ± 5
Superstition Hills	26.1	41.8	6.6	23 ± 2	4 ± 2
Superstition Mountain	30.4	48.6	6.6	24 ± 2	5 ± 3
San Jacinto - Borrego	32.7	52.3	6.6	29 ± 3	4 ± 2
San Jacinto - Anza	33.1	52.9	7.2	91 ± 9	12 ± 6
Rico *	36.0	57.5			
Painted Gorge Wash*	36.9	59.1			
San Jacinto - Coyote Creek	39.5	63.2	6.8	41 ± 4	4 ± 2
Yuha Well *	41.8	66.8			
Route 247*	42.0	67.2			
Shell Beds	42.3	67.7			
Vista de Anza*	43.3	69.2			
Yuha*	43.8	70.2			
Northern Centinela*	44.6	71.4			
Indio Hills *	44.8	71.8			
Ocotillo*	45.2	72.3			
Laguna Salada	45.8	73.3	7	67 ± 7	3.5 ± 1.5
Elsinore - Coyote Mountain	46.0	73.6	6.8	39 ± 4	4 ± 2

* Note: Faults not included in CGS database.

**Table 2
2019 California Building Code (CBC) and ASCE 7-16 Seismic Parameters**

Soil Site Class:	D	<u>ASCE 7-16 Reference</u>
Latitude:	33.3191 N	Table 20.3-1
Longitude:	-115.5516 W	
Risk Category:	II	
Seismic Design Category:	D	

Maximum Considered Earthquake (MCE) Ground Motion

Mapped MCE _R Short Period Spectral Response	S_s	1.500 g	ASCE Figure 22-1
Mapped MCE _R 1 second Spectral Response	S₁	0.567 g	ASCE Figure 22-2
Short Period (0.2 s) Site Coefficient	F_a	1.00	ASCE Table 11.4-1
Long Period (1.0 s) Site Coefficient	F_v	1.74	ASCE Table 11.4-2
MCE _R Spectral Response Acceleration Parameter (0.2 s)	S_{MS}	1.500 g	= F _a * S _s ASCE Equation 11.4-1
MCE _R Spectral Response Acceleration Parameter (1.0 s)	S_{MI}	0.987 g	= F _v * S ₁ ASCE Equation 11.4-2

Design Earthquake Ground Motion

Design Spectral Response Acceleration Parameter (0.2 s)	S_{DS}	1.000 g	= 2/3*S _{MS}	ASCE Equation 11.4-3
Design Spectral Response Acceleration Parameter (1.0 s)	S_{DI}	0.658 g	= 2/3*S _{MI}	ASCE Equation 11.4-4
Risk Coefficient at Short Periods (less than 0.2 s)	C_{RS}	0.942		ASCE Figure 22-17
Risk Coefficient at Long Periods (greater than 1.0 s)	C_{RI}	0.913		ASCE Figure 22-18
	T_L	8.00 sec		ASCE Figure 22-12
	T_O	0.13 sec	= 0.2*S _{DI} /S _{DS}	
	T_S	0.66 sec	= S _{DI} /S _{DS}	
Peak Ground Acceleration	PGA_M	0.59 g		ASCE Equation 11.8-1

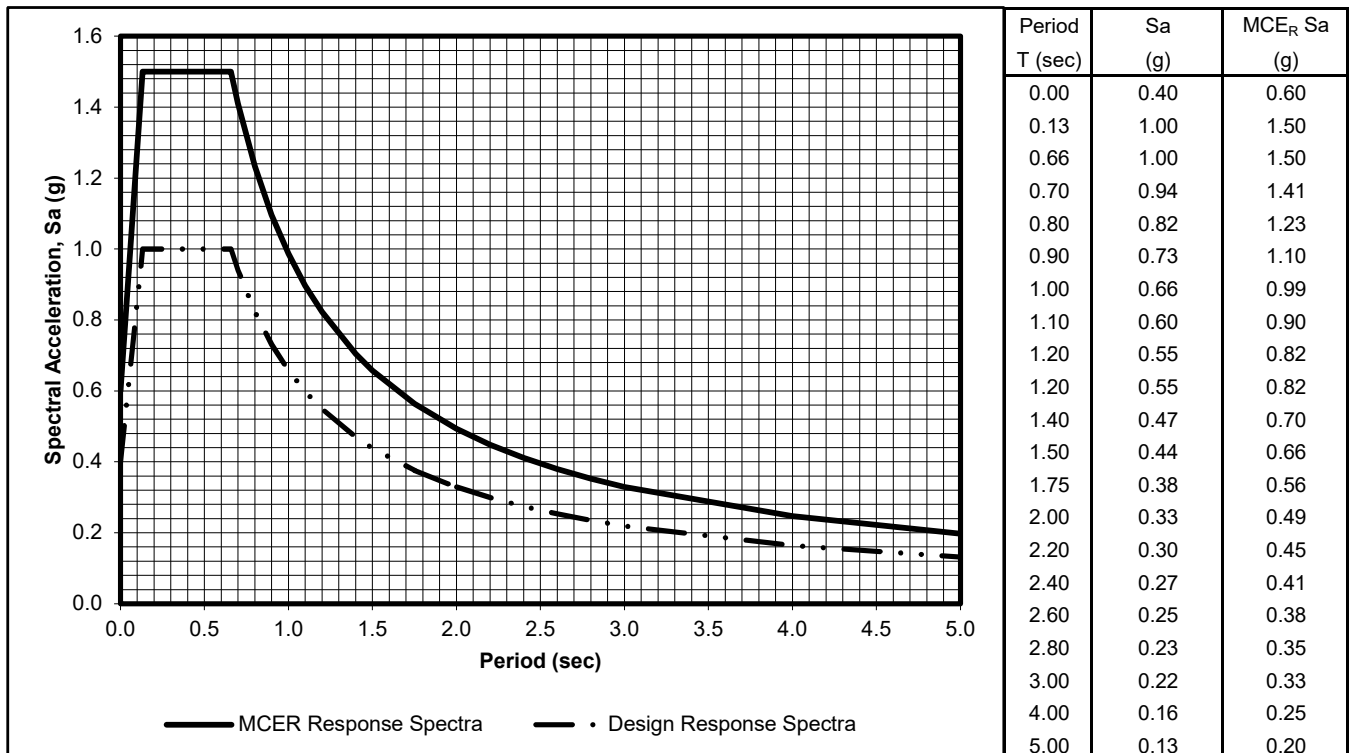

FIGURES

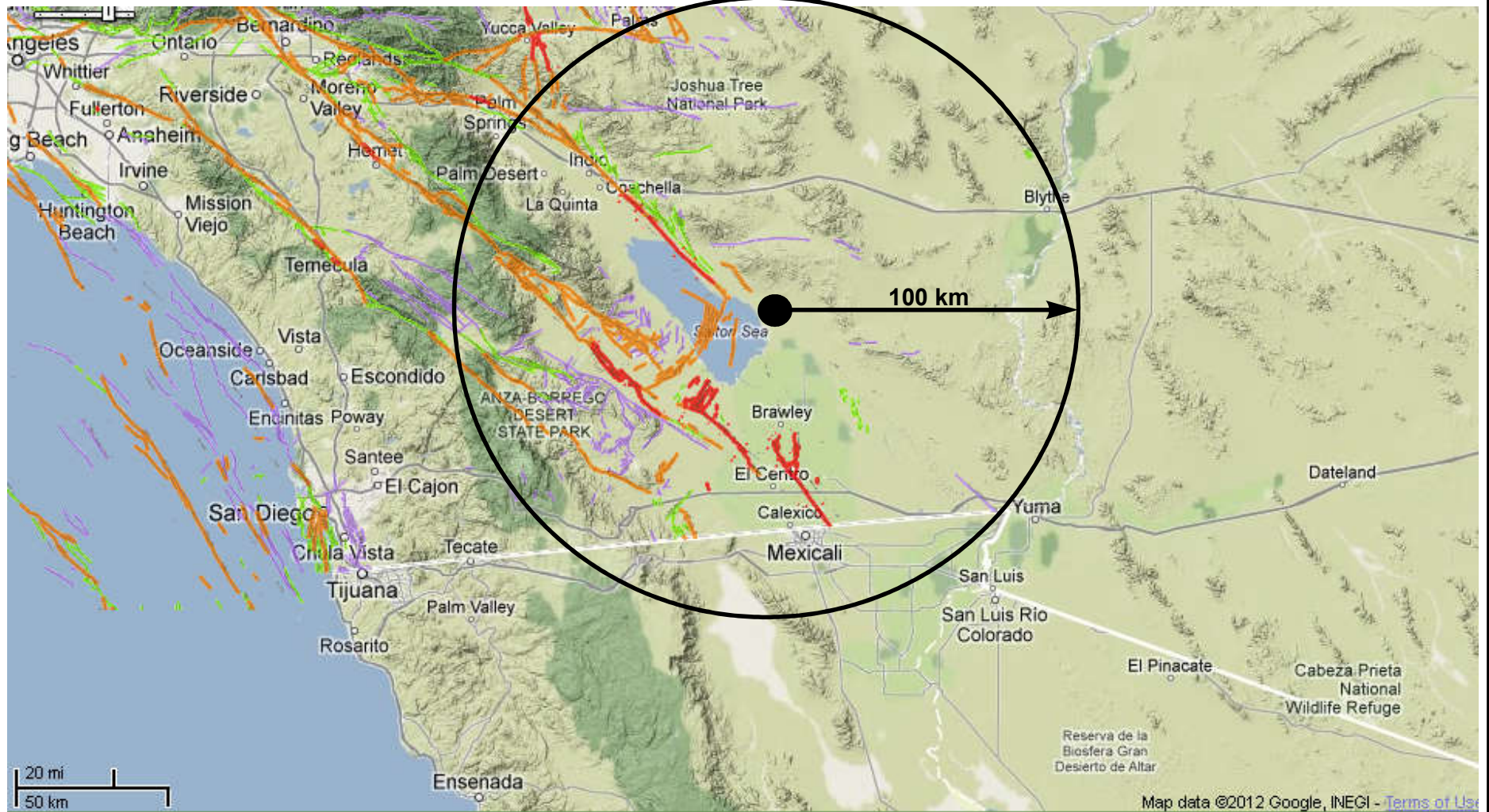

Source: California Geological Survey 2010 Fault Activity Map of California
<http://www.quake.ca.gov/gmaps/FAM/faultactivitymap.html#>

LANDMARK
 Geo-Engineers and Geologists

Project No.: LE22169

Regional Fault Map

Figure 1

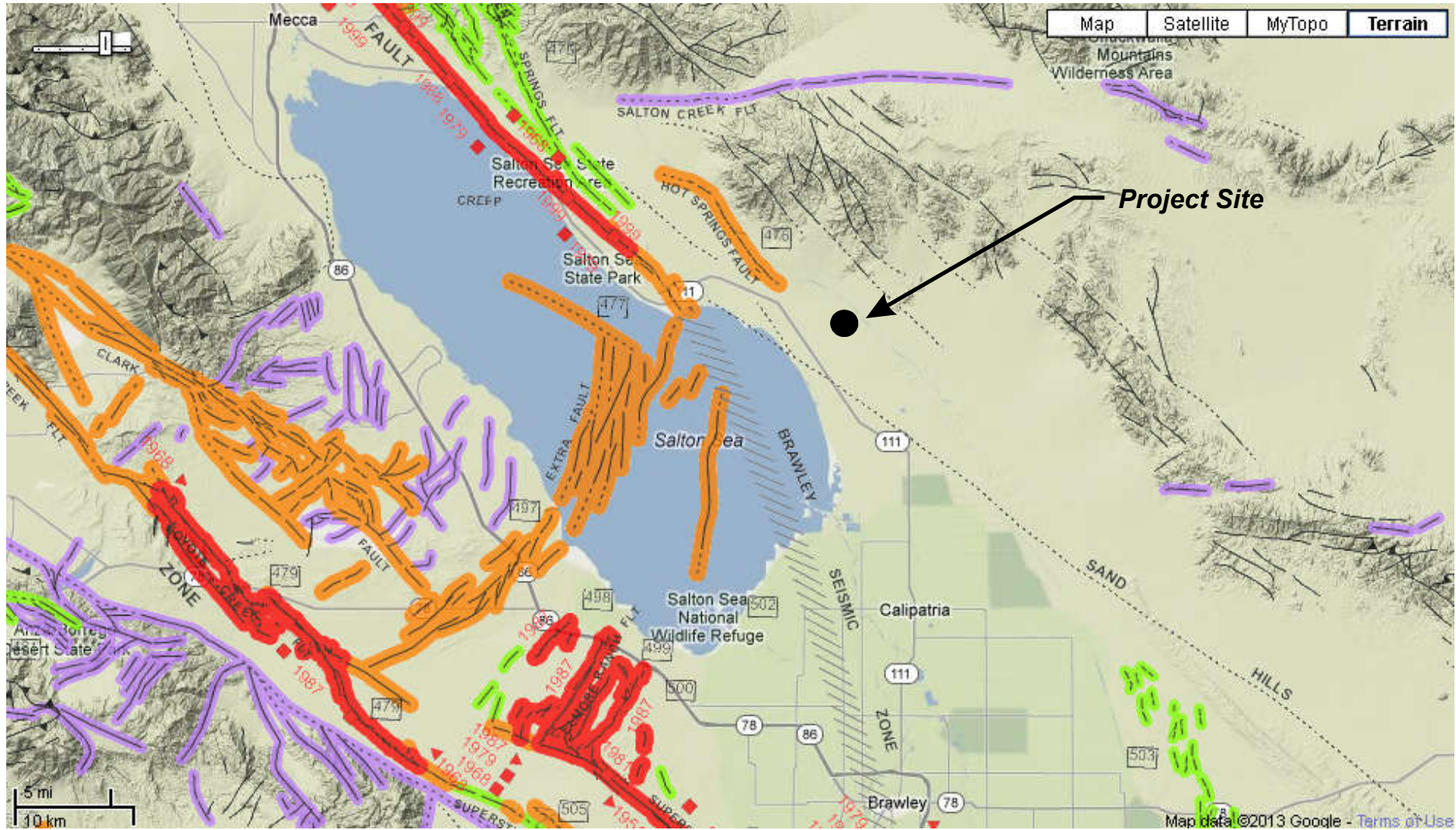

Source: California Geological Survey 2010 Fault Activity Map of California
<http://www.quake.ca.gov/gmaps/FAM/faultactivitymap.html#>

LANDMARK
 Geo-Engineers and Geologists

Project No.: LE22169

Map of Local Faults

Figure 2

APPENDIX A

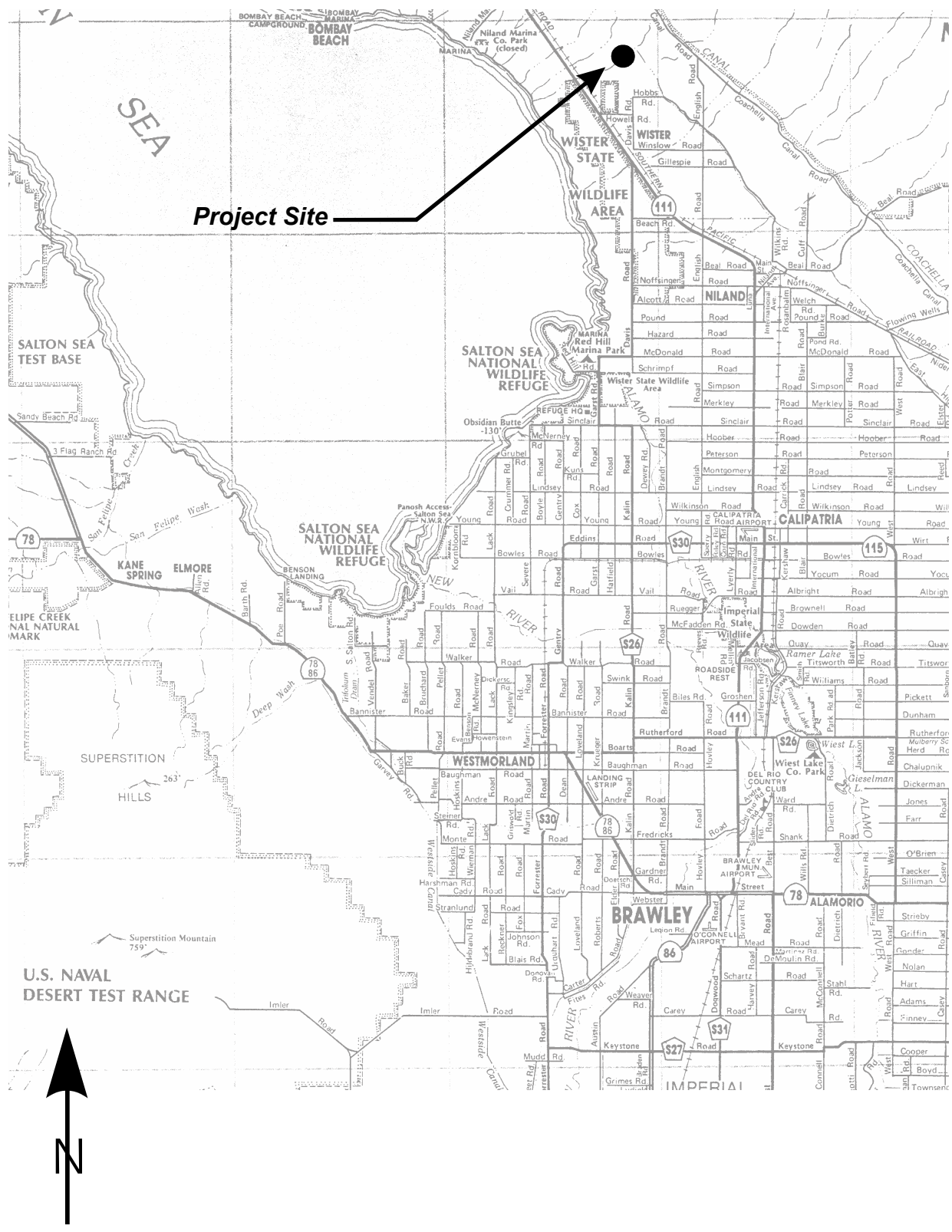

Project Site

LANDMARK
 Geo-Engineers and Geologists
 Project No.: LE22169

Vicinity Map

**Plate
 A-1**

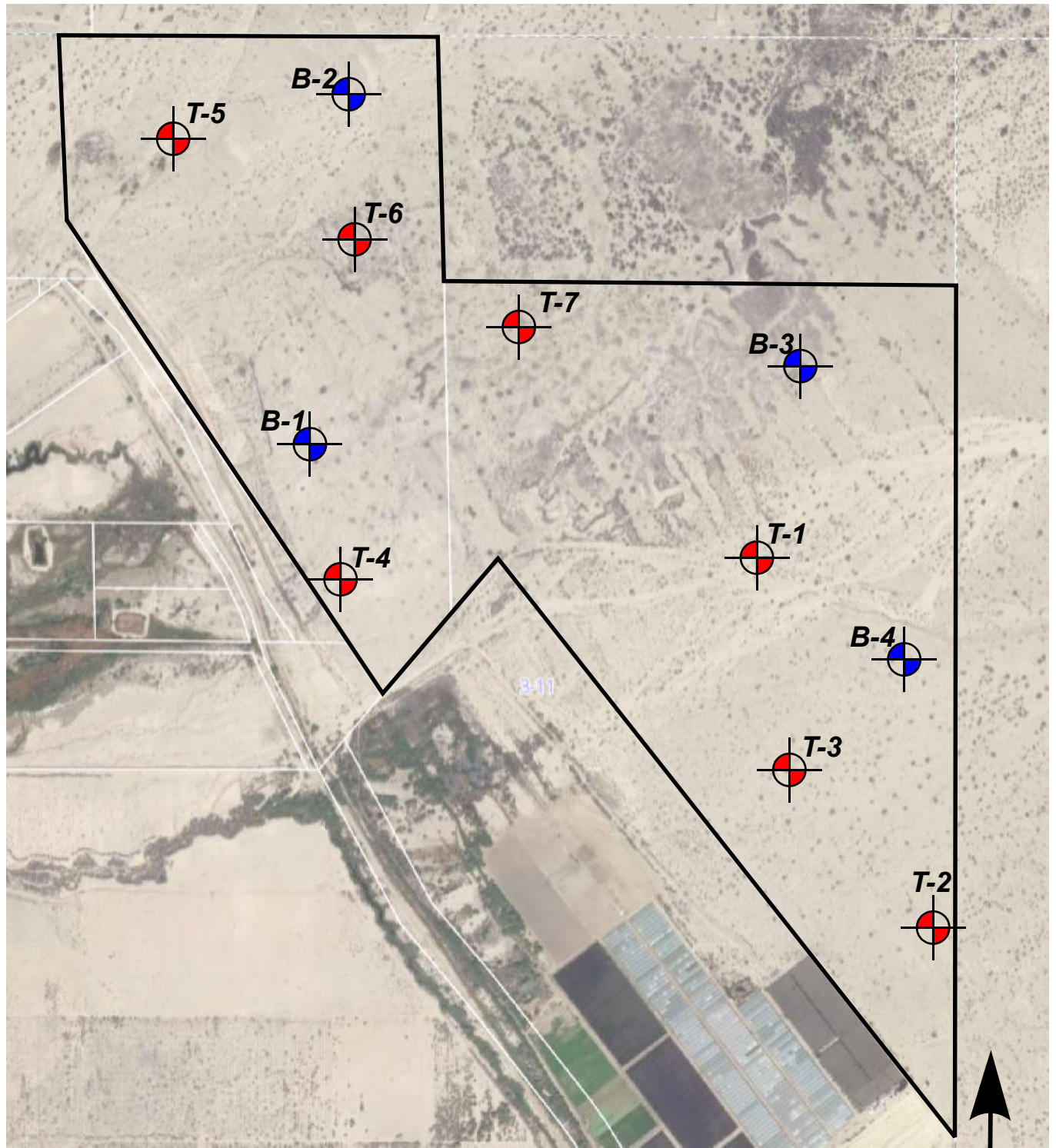

LANDMARK
Geo-Engineers and Geologists

Project No.: LE22169

Site Map

Plate
A-2

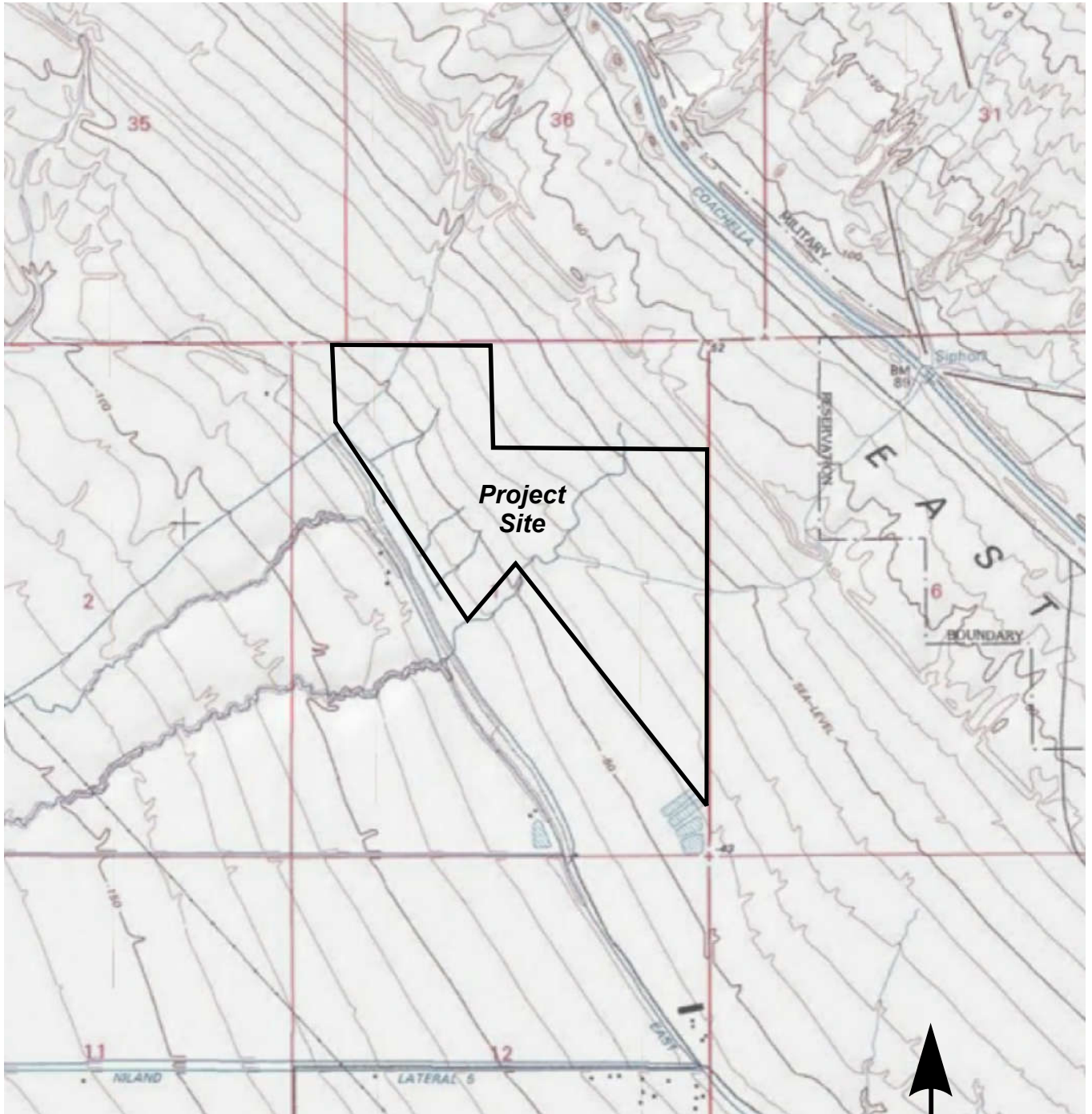

LANDMARK
Geo-Engineers and Geologists

Project No.: LE22169

Topographic Map

Plate
A-3

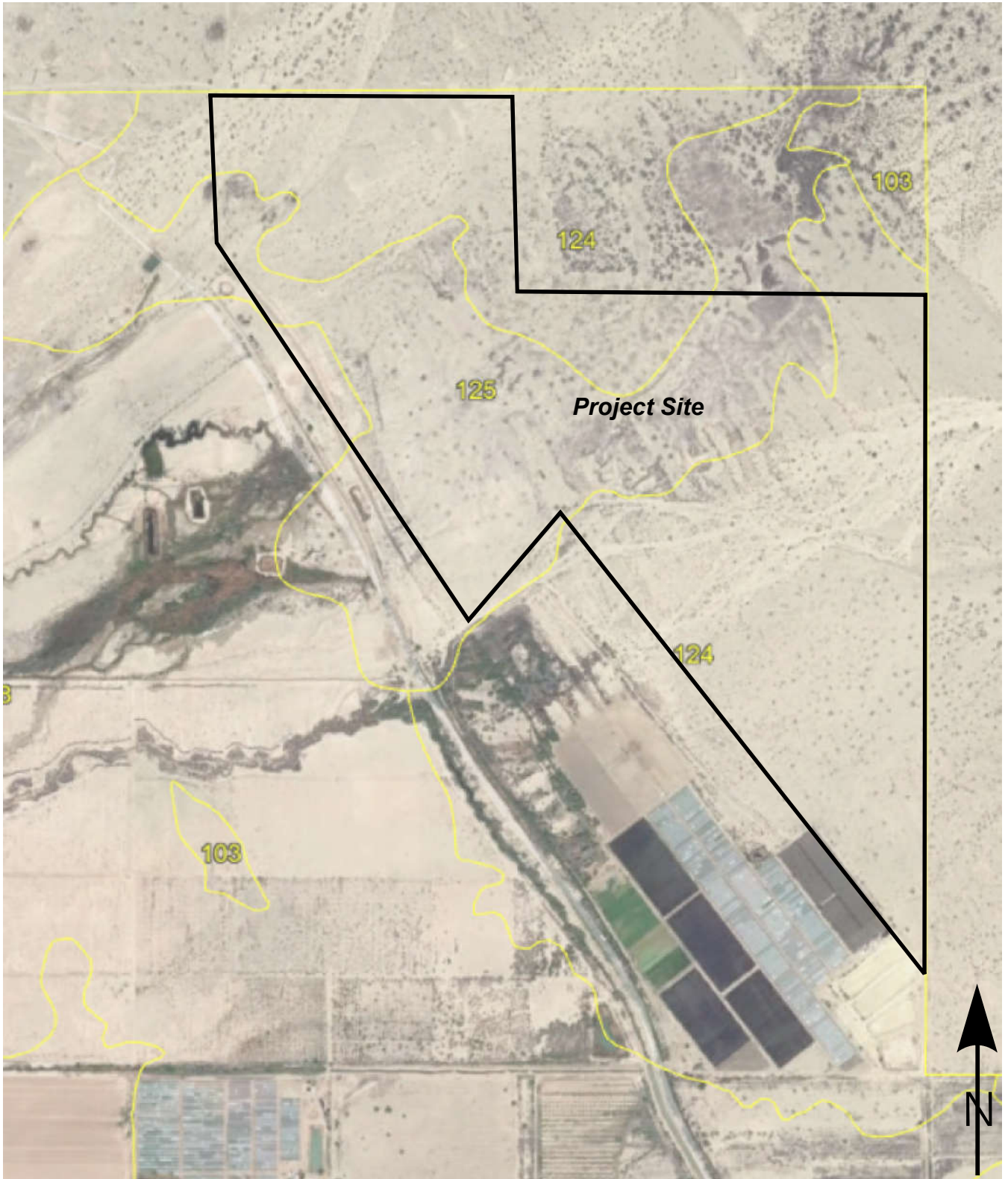

LANDMARK
Geo-Engineers and Geologists

Project No.: LE22169

Soil Survey Map

Plate
A-4

Soil Survey of

**IMPERIAL COUNTY
CALIFORNIA
IMPERIAL VALLEY AREA**

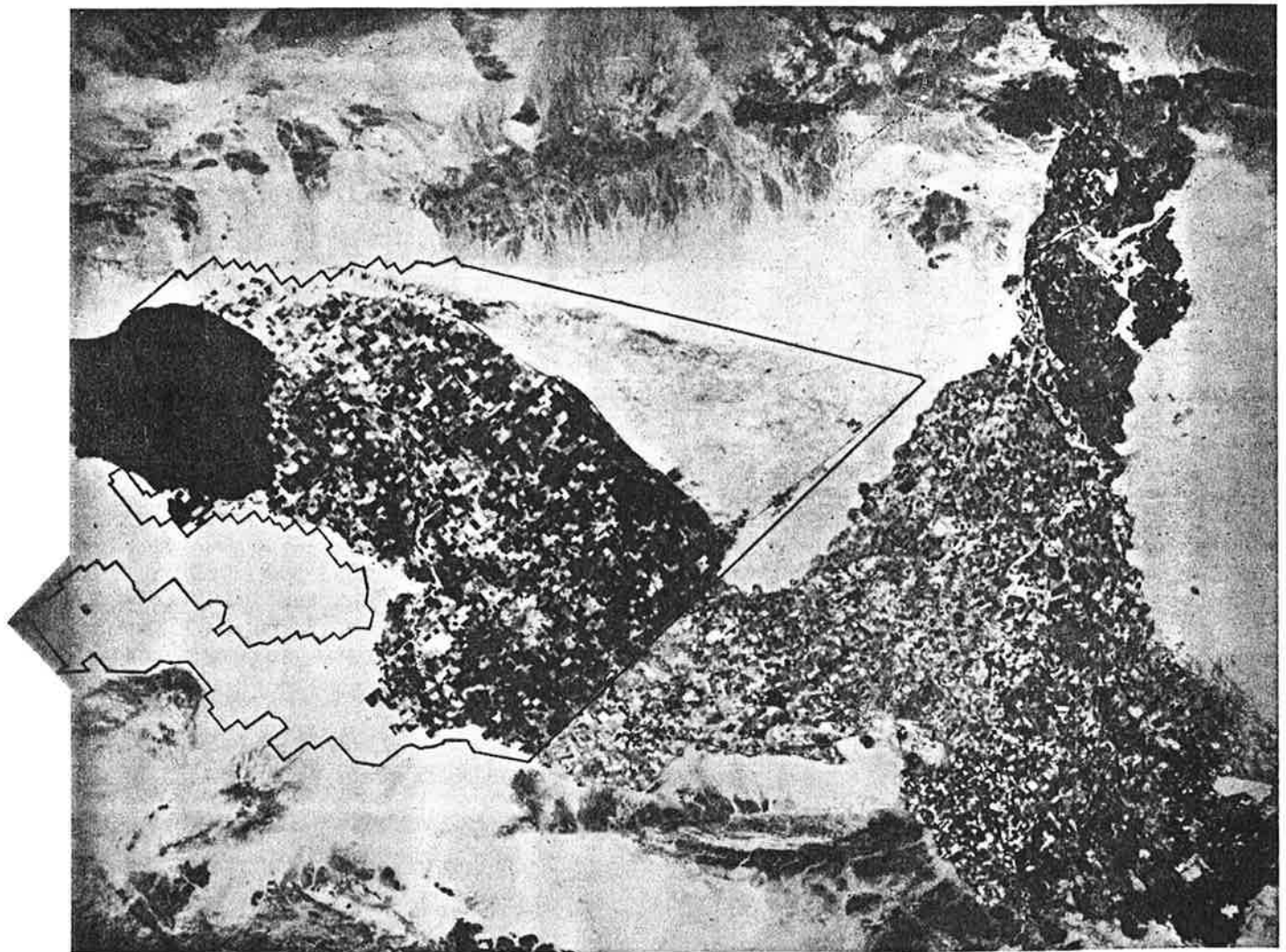

United States Department of Agriculture Soil Conservation Service
in cooperation with
University of California Agricultural Experiment Station
and
Imperial Irrigation District

TABLE 11.--ENGINEERING INDEX PROPERTIES

[The symbol > means more than. Absence of an entry indicates that data were not estimated]

Soil name and map symbol	Depth	USDA texture	Classification		Frag-ments > 3 inches	Percentage passing sieve number--				Liquid limit	Plas-ticity index
			Unified	AASHTO		4	10	40	200		
	In				Pct					Pct	
100-----	0-13	Loamy fine sand	SM	A-2	0	100	100	75-85	10-30	---	NP
Antho	13-60	Sandy loam, fine sandy loam.	SM	A-2, A-4	0	90-100	75-95	50-60	15-40	---	NP
101*:											
Antho-----	0-8	Loamy fine sand	SM	A-2	0	100	100	75-85	10-30	---	NP
	8-60	Sandy loam, fine sandy loam.	SM	A-2, A-4	0	90-100	75-95	50-60	15-40	---	NP
Superstition-----	0-6	Fine sand-----	SM	A-2	0	100	95-100	70-85	15-25	---	NP
	6-60	Loamy fine sand, fine sand, sand.	SM	A-2	0	100	95-100	70-85	15-25	---	NP
102*.											
Badland											
103-----	0-10	Gravelly sand---	SP, SP-SM	A-1, A-2	0-5	60-90	50-85	30-55	0-10	---	NP
Carsitas	10-60	Gravelly sand, gravelly coarse sand, sand.	SP, SP-SM	A-1	0-5	60-90	50-85	25-50	0-10	---	NP
104*											
Fluvaquents											
105-----	0-13	Clay loam-----	CL	A-6	0	100	100	90-100	70-95	35-45	15-30
Glenbar	13-60	Clay loam, silty clay loam.	CL	A-6	0	100	100	90-100	70-95	35-45	15-30
106-----	0-13	Clay loam-----	CL	A-6, A-7	0	100	100	90-100	70-95	35-45	15-25
Glenbar	13-60	Clay loam, silty clay loam.	CL	A-6, A-7	0	100	100	90-100	70-95	35-45	15-25
107*-----	0-13	Loam-----	ML, CL-ML, CL	A-4	0	100	100	100	70-80	20-30	NP-10
Glenbar	13-60	Clay loam, silty clay loam.	CL	A-6, A-7	0	100	100	95-100	75-95	35-45	15-30
108-----	0-14	Loam-----	ML	A-4	0	100	100	85-100	55-95	25-35	NP-10
Holtville	14-22	Clay, silty clay	CL, CH	A-7	0	100	100	95-100	85-95	40-65	20-35
	22-60	Silt loam, very fine sandy loam.	ML	A-4	0	100	100	95-100	65-85	25-35	NP-10
109-----	0-17	Silty clay-----	CL, CH	A-7	0	100	100	95-100	85-95	40-65	20-35
Holtville	17-24	Clay, silty clay	CL, CH	A-7	0	100	100	95-100	85-95	40-65	20-35
	24-35	Silt loam, very fine sandy loam.	ML	A-4	0	100	100	95-100	65-85	25-35	NP-10
	35-60	Loamy very fine sand, loamy fine sand.	SM, ML	A-2, A-4	0	100	100	75-100	20-55	---	NP
110-----	0-17	Silty clay-----	CH, CL	A-7	0	100	100	95-100	85-95	40-65	20-35
Holtville	17-24	Clay, silty clay	CH, CL	A-7	0	100	100	95-100	85-95	40-65	20-35
	24-35	Silt loam, very fine sandy loam.	ML	A-4	0	100	100	95-100	55-85	25-35	NP-10
	35-60	Loamy very fine sand, loamy fine sand.	SM, ML	A-2, A-4	0	100	100	75-100	20-55	---	NP

See footnote at end of table.

TABLE 11.--ENGINEERING INDEX PROPERTIES--Continued

Soil name and map symbol	Depth	USDA texture	Classification		Frag-ments > 3 inches	Percentage passing sieve number--				Liquid limit	Plas-ticity index
			Unified	AASHTO		4	10	40	200		
	In				Pct					Pct	
111*: Holtville-----	0-10	Silty clay loam	CL, CH	A-7	0	100	100	95-100	85-95	40-65	20-35
	10-22	Clay, silty clay	CL, CH	A-7	0	100	100	95-100	85-95	40-65	20-35
	22-60	Silt loam, very fine sandy loam.	ML	A-4	0	100	100	95-100	65-85	25-35	NP-10
Imperial-----	0-12	Silty clay loam	CL	A-7	0	100	100	100	85-95	40-50	10-20
	12-60	Silty clay loam, silty clay, clay.	CH	A-7	0	100	100	100	85-95	50-70	25-45
112----- Imperial	0-12	Silty clay-----	CH	A-7	0	100	100	100	85-95	50-70	25-45
	12-60	Silty clay loam, silty clay, clay.	CH	A-7	0	100	100	100	85-95	50-70	25-45
113----- Imperial	0-12	Silty clay-----	CH	A-7	0	100	100	100	85-95	50-70	25-45
	12-60	Silty clay, clay, silty clay loam.	CH	A-7	0	100	100	100	85-95	50-70	25-45
114----- Imperial	0-12	Silty clay-----	CH	A-7	0	100	100	100	85-95	50-70	25-45
	12-60	Silty clay loam, silty clay, clay.	CH	A-7	0	100	100	100	85-95	50-70	25-45
115*: Imperial-----	0-12	Silty clay loam	CL	A-7	0	100	100	100	85-95	40-50	10-20
	12-60	Silty clay loam, silty clay, clay.	CH	A-7	0	100	100	100	85-95	50-70	25-45
Glenbar-----	0-13	Silty clay loam	CL	A-6, A-7	0	100	100	90-100	70-95	35-45	15-25
	13-60	Clay loam, silty clay loam.	CL	A-6, A-7	0	100	100	90-100	70-95	35-45	15-25
116*: Imperial-----	0-13	Silty clay loam	CL	A-7	0	100	100	100	85-95	40-50	10-20
	13-60	Silty clay loam, silty clay, clay.	CH	A-7	0	100	100	100	85-95	50-70	25-45
Glenbar-----	0-13	Silty clay loam	CL	A-6, A-7	0	100	100	90-100	70-95	35-45	15-25
	13-60	Clay loam, silty clay loam.	CL	A-6	0	100	100	90-100	70-95	35-45	15-30
117, 118----- Indio	0-12	Loam-----	ML	A-4	0	95-100	95-100	85-100	75-90	20-30	NP-5
	12-72	Stratified loamy very fine sand to silt loam.	ML	A-4	0	95-100	95-100	85-100	75-90	20-30	NP-5
119*: Indio-----	0-12	Loam-----	ML	A-4	0	95-100	95-100	85-100	75-90	20-30	NP-5
	12-72	Stratified loamy very fine sand to silt loam.	ML	A-4	0	95-100	95-100	85-100	75-90	20-30	NP-5
Vint-----	0-10	Loamy fine sand	SM	A-2	0	95-100	95-100	70-80	25-35	---	NP
	10-60	Loamy sand, loamy fine sand.	SM	A-2	0	95-100	95-100	70-80	20-30	---	NP
120*----- Laveen	0-12	Loam-----	ML, CL-ML	A-4	0	100	95-100	75-85	55-65	20-30	NP-10
	12-60	Loam, very fine sandy loam.	ML, CL-ML	A-4	0	95-100	85-95	70-80	55-65	15-25	NP-10

See footnote at end of table.

TABLE 11.--ENGINEERING INDEX PROPERTIES--Continued

Soil name and map symbol	Depth In	USDA texture	Classification		Frag- ments > 3 inches Pct	Percentage passing sieve number--				Liquid limit Pet	Plas- ticity index
			Unified	AASHTO		4	10	40	200		
121----- Meloland	0-12	Fine sand-----	SM, SP-SM	A-2, A-3	0	95-100	90-100	75-100	5-30	---	NP
	12-26	Stratified loamy fine sand to silt loam.	ML	A-4	0	100	100	90-100	50-65	25-35	NP-10
	26-71	Clay, silty clay, silty clay loam.	CL, CH	A-7	0	100	100	95-100	85-95	40-65	20-40
122----- Meloland	0-12	Very fine sandy loam.	ML	A-4	0	95-100	95-100	95-100	55-85	25-35	NP-10
	12-26	Stratified loamy fine sand to silt loam.	ML	A-4	0	100	100	90-100	50-70	25-35	NP-10
	26-71	Clay, silty clay, silty clay loam.	CH, CL	A-7	0	100	100	95-100	85-95	40-65	20-40
123*: Meloland-----	0-12	Loam-----	ML	A-4	0	95-100	95-100	95-100	55-85	25-35	NP-10
	12-26	Stratified loamy fine sand to silt loam.	ML	A-4	0	100	100	90-100	50-70	25-35	NP-10
	26-38	Clay, silty clay, silty clay loam.	CH, CL	A-7	0	100	100	95-100	85-95	40-65	20-40
	38-60	Stratified silt loam to loamy fine sand.	SM, ML	A-4	0	100	100	75-100	35-55	25-35	NP-10
Holtville-----	0-12	Loam-----	ML	A-4	0	100	100	85-100	55-95	25-35	NP-10
	12-24	Clay, silty clay	CH, CL	A-7	0	100	100	95-100	85-95	40-65	20-35
	24-36	Silt loam, very fine sandy loam.	ML	A-4	0	100	100	95-100	55-85	25-35	NP-10
	36-60	Loamy very fine sand, loamy fine sand.	SM, ML	A-2, A-4	0	100	100	75-100	20-55	---	NP
124, 125----- Niland	0-23	Gravelly sand---	SM, SP-SM	A-2, A-3	0	90-100	70-95	50-65	5-25	---	NP
	23-60	Silty clay, clay, clay loam.	CL, CH	A-7	0	100	100	85-100	80-95	40-65	20-40
126----- Niland	0-23	Fine sand-----	SM, SP-SM	A-2, A-3	0	90-100	90-100	50-65	5-25	---	NP
	23-60	Silty clay-----	CL, CH	A-7	0	100	100	85-100	80-95	40-65	20-40
127----- Niland	0-23	Loamy fine sand	SM	A-2	0	90-100	90-100	50-65	15-30	---	NP
	23-60	Silty clay-----	CL, CH	A-7	0	100	100	85-100	80-95	40-65	20-40
128*: Niland-----	0-23	Gravelly sand---	SM, SP-SM	A-2, A-3	0	90-100	70-95	50-65	5-25	---	NP
	23-60	Silty clay, clay, clay loam.	CL, CH	A-7	0	100	100	85-100	80-100	40-65	20-40
Imperial-----	0-12	Silty clay-----	CH	A-7	0	100	100	100	85-95	50-70	25-45
	12-60	Silty clay loam, silty clay, clay.	CH	A-7	0	100	100	100	85-95	50-70	25-45
129*: Pits											
130, 131----- Rositas	0-27	Sand-----	SP-SM	A-3, A-1, A-2	0	100	80-100	40-70	5-15	---	NP
	27-60	Sand, fine sand, loamy sand.	SM, SP-SM	A-3, A-2, A-1	0	100	80-100	40-85	5-30	---	NP

See footnote at end of table.

TABLE 11.--ENGINEERING INDEX PROPERTIES--Continued

Soil name and map symbol	Depth	USDA texture	Classification		Frag-ments > 3 inches	Percentage passing sieve number--				Liquid limit	Plas-ticity index
			Unified	AASHTO		4	10	40	200		
	In				Pct					Pct	
132, 133, 134, 135-Rositas	0-9	Fine sand-----	SM	A-3, A-2	0	100	80-100	50-80	10-25	---	NP
	9-60	Sand, fine sand, loamy sand.	SM, SP-SM	A-3, A-2, A-1	0	100	80-100	40-85	5-30	---	NP
136-----Rositas	0-4	Loamy fine sand	SM	A-1, A-2	0	100	80-100	40-85	10-35	---	NP
	4-60	Sand, fine sand, loamy sand.	SM, SP-SM	A-3, A-2, A-1	0	100	80-100	40-85	5-30	---	NP
137-----Rositas	0-12	Silt loam-----	ML	A-4	0	100	100	90-100	70-90	20-30	NP-5
	12-60	Sand, fine sand, loamy sand.	SM, SP-SM	A-3, A-2, A-1	0	100	80-100	40-85	5-30	---	NP
138*: Rositas-----	0-4	Loamy fine sand	SM	A-1, A-2	0	100	80-100	40-85	10-35	---	NP
	4-60	Sand, fine sand, loamy sand.	SM, SP-SM	A-3, A-2, A-1	0	100	80-100	40-85	5-30	---	NP
Superstition-----	0-6	Loamy fine sand	SM	A-2	0	100	95-100	70-85	15-25	---	NP
	6-60	Loamy fine sand, fine sand, sand.	SM	A-2	0	100	95-100	70-85	15-25	---	NP
139-----Superstition	0-6	Loamy fine sand	SM	A-2	0	100	95-100	70-85	15-25	---	NP
	6-60	Loamy fine sand, fine sand, sand.	SM	A-2	0	100	95-100	70-85	15-25	---	NP
140*: Torriorthents											
Rock outcrop											
141*: Torriorthents											
Orthids											
142-----Vint	0-10	Loamy very fine sand.	SM, ML	A-4	0	100	100	85-95	40-65	15-25	NP-5
	10-60	Loamy fine sand	SM	A-2	0	95-100	95-100	70-80	20-30	---	NP
143-----Vint	0-12	Fine sandy loam	ML, CL-ML, SM, SM-SC	A-4	0	100	100	75-85	45-55	15-25	NP-5
	12-60	Loamy sand, loamy fine sand.	SM	A-2	0	95-100	95-100	70-80	20-30	---	NP
144*: Vint-----	0-10	Very fine sandy loam.	SM, ML	A-4	0	100	100	85-95	40-65	15-25	NP-5
	10-40	Loamy fine sand	SM	A-2	0	95-100	95-100	70-80	20-30	---	NP
	40-60	Silty clay-----	CL, CH	A-7	0	100	100	95-100	85-95	40-65	20-35
Indio-----	0-12	Very fine sandy loam.	ML	A-4	0	95-100	95-100	85-100	75-90	20-30	NP-5
	12-40	Stratified loamy very fine sand to silt loam.	ML	A-4	0	95-100	95-100	85-100	75-90	20-30	NP-5
	40-72	Silty clay-----	CL, CH	A-7	0	100	100	95-100	85-95	40-65	20-35

* See description of the map unit for composition and behavior characteristics of the map unit.

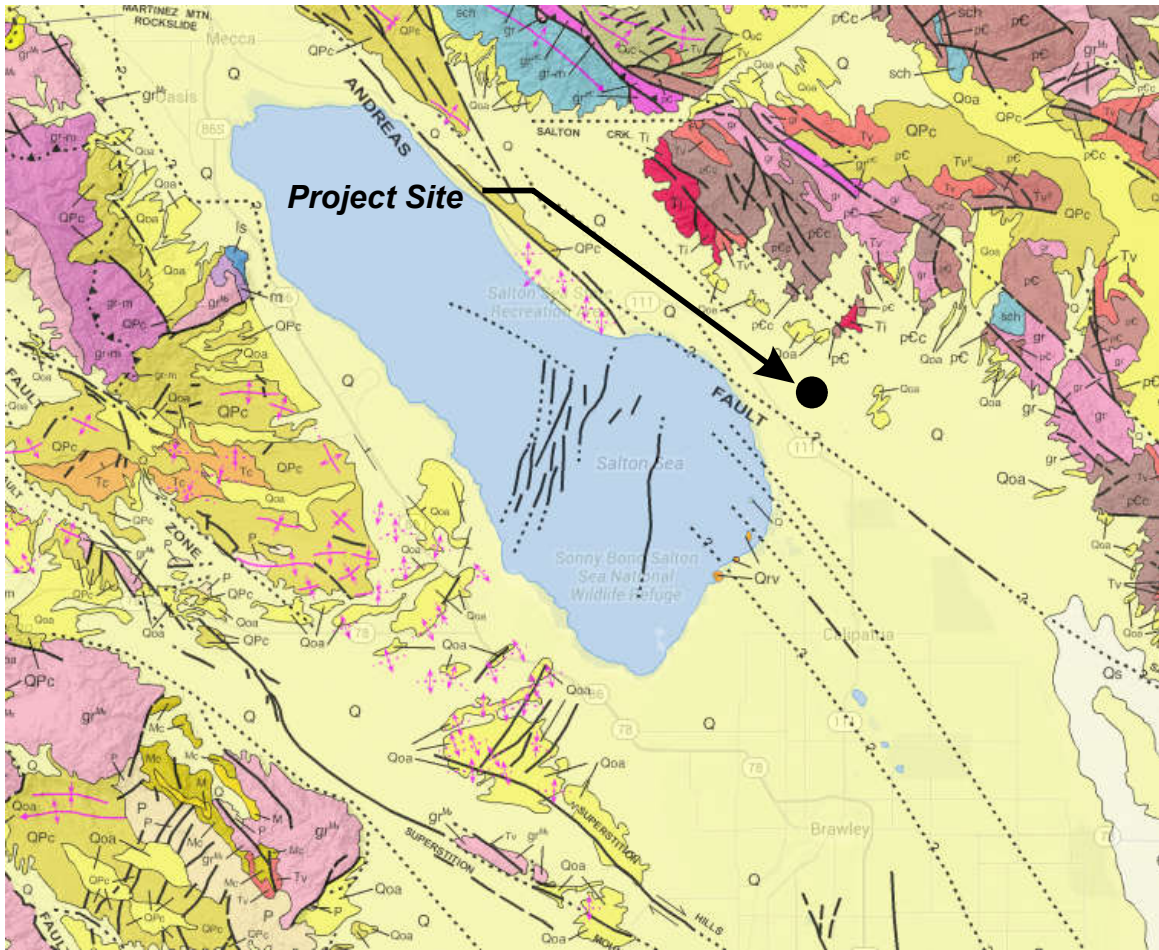

GEOLOGIC LEGEND

Quaternary Deposits

Qs
Q
Qls
Qg
Qoa
QPc

Quaternary Volcanic Rocks

Qrv	Qrv'
Qv	Qv'

Tertiary Sedimentary Rocks

Tc	
P	
M	Mc
Qc	Qc'
E	Ec
Ep	

Tertiary Volcanic Rocks

Tv	Tv'
Ti	

Tertiary Plutonic Rocks

gr ⁿ

Mesozoic Sedimentary and Metasedimentary Rocks

TK		
K		
Ku		
Kl		
KJf	KJf _m	KJf _s
J		
T _r		
sch		
ls		

Mesozoic Mixed Rocks

gr-m

Mesozoic Metavolcanic Rocks

Me-v
mv

Mesozoic Plutonic Rocks

gr ^{sh}
um
gb
gr

Paleozoic Sedimentary and Metasedimentary Rocks

Pz
Pm
C
D
SO
c

Paleozoic Mixed Rocks

m

Paleozoic Metavolcanic Rocks

Pz-v

Paleozoic Plutonic Rocks

gr ⁿ

Pre-Cambrian Rocks

pC
pCc
gr ⁿ

SYMBOLS

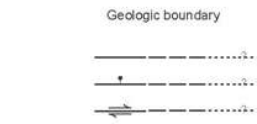

Fault traces - solid where well located, dashed where approximately located or inferred, dotted where concealed, and queried where continuation or existence is uncertain. Ball and bar on downthrown side (relative or apparent). Arrows indicate direction of lateral movement (relative or apparent).

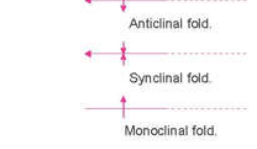
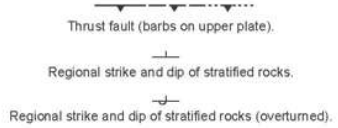

Site Location
 Lat N33.2712 Long: W-115.5066

LANDMARK
 Geo-Engineers and Geologists
 Project No.: LE22169

Regional Geologic Map

Plate A-5

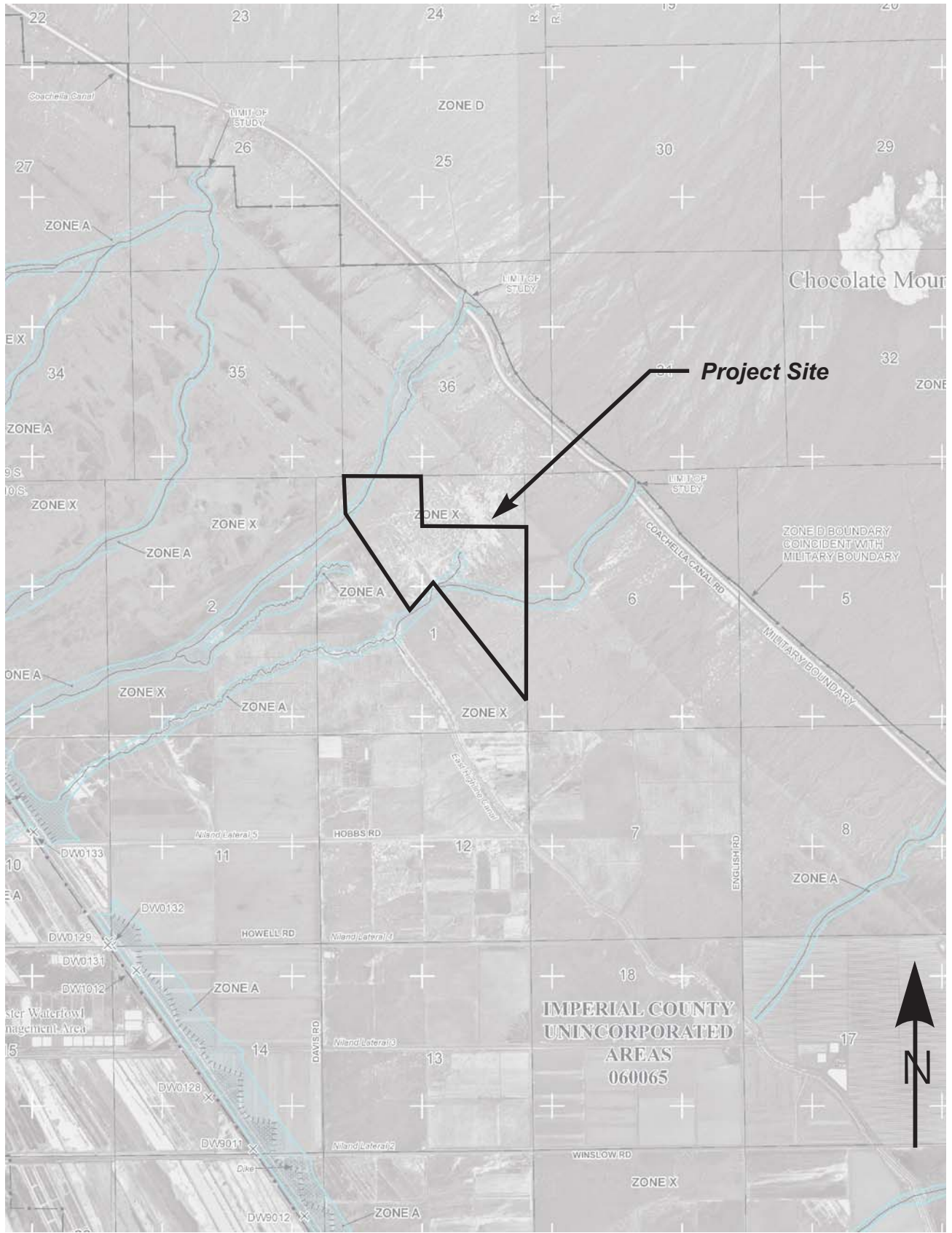

LANDMARK
 Geo-Engineers and Geologists
 Project No.: LE22169

FEMA Flood Map

Plate
 A-6

LEGEND



SPECIAL FLOOD HAZARD AREAS SUBJECT TO INUNDATION BY THE 1% ANNUAL CHANCE FLOOD

The 1% annual flood (100-year flood), also known as the base flood, is the flood that has a 1% chance of being equaled or exceeded in any given year. The Special Flood Hazard Area is the area subject to flooding by the 1% annual chance flood. Areas of Special Flood Hazard include Zones A, AE, AH, AO, AR, A99, V, and VE. The Base Flood Elevation is the water-surface elevation of the 1% annual chance flood.

- ZONE A** No Base Flood Elevations determined.
- ZONE AE** Base Flood Elevations determined.
- ZONE AH** Flood depths of 1 to 3 feet (usually areas of ponding); Base Flood Elevations determined.
- ZONE AO** Flood depths of 1 to 3 feet (usually sheet flow on sloping terrain); average depths determined. For areas of alluvial fan flooding, velocities also determined.
- ZONE AR** Special Flood Hazard Area formerly protected from the 1% annual chance flood by a flood control system that was subsequently decertified. Zone AR indicates that the former flood control system is being restored to provide protection from the 1% annual chance or greater flood.
- ZONE A99** Area to be protected from 1% annual chance flood by a Federal flood protection system under construction; no Base Flood Elevations determined.
- ZONE V** Coastal flood zone with velocity hazard (wave action); no Base Flood Elevations determined.
- ZONE VE** Coastal flood zone with velocity hazard (wave action); Base Flood Elevations determined.



FLOODWAY AREAS IN ZONE AE

The floodway is the channel of a stream plus any adjacent floodplain areas that must be kept free of encroachment so that the 1% annual chance flood can be carried without substantial increases in flood heights.



OTHER FLOOD AREAS

- ZONE X** Areas of 0.2% annual chance flood; areas of 1% annual chance flood with average depths of less than 1 foot or with drainage areas less than 1 square mile; and areas protected by levees from 1% annual chance flood.



OTHER AREAS

- ZONE X** Areas determined to be outside the 0.2% annual chance floodplain.
- ZONE D** Areas in which flood hazards are undetermined, but possible.



COASTAL BARRIER RESOURCES SYSTEM (CBRS) AREAS



OTHERWISE PROTECTED AREAS (OPAs)

CBRS areas and OPAs are normally located within or adjacent to Special Flood Hazard Areas.

- 1% annual chance floodplain boundary
- 0.2% annual chance floodplain boundary
- Floodway boundary
- Zone D boundary
- CBRS and OPA boundary
- Boundary dividing Special Flood Hazard Area Zones and boundary dividing Special Flood Hazard Areas of different Base Flood Elevations, flood depths or flood velocities.
- Base Flood Elevation line and value; elevation in feet*
- Base Flood Elevation value where uniform within zone; elevation in feet*

* Referenced to the North American Vertical Datum of 1988

- Cross section line
- Transect line
- Geographic coordinates referenced to the North American Datum of 1983 (NAD 83), Western Hemisphere
- 1000-meter Universal Transverse Mercator grid values, zone 11N
- 5000-foot grid ticks: California State Plane coordinate system, zone VI (FIPZONE 0406), Lambert Conformal Conic projection
- Bench mark (see explanation in Notes to Users section of this FIRM panel)
- River Mile

APPENDIX B

DEPTH	FIELD				LOG OF BORING NO. TP-1 SHEET 1 OF 1	LABORATORY		
	SAMPLE	USCS CLASS.	BLOW COUNT	POCKET PEN. (tsf)		DESCRIPTION OF MATERIAL	DRY DENSITY (pcf)	MOISTURE CONTENT (% dry wt.)
5					GRAVELLY SAND (SP): Gray, dry, coarse and fine gravels, trace cobbles at surface.	102.4	9.1	
					CLAY (CH): Olive brown, very moist, very stiff to hard, high plasticity.	100.2	17.8	
						92.8	24.4	
10					Total Depth = 6.5 ft. No groundwater encountered Backfilled with excavated soil			
15								
20								
25								
30								

DATE DRILLED: 8/31/22 TOTAL DEPTH: 6.5 Feet DEPTH TO WATER: NA
 LOGGED BY: P. LaBrucherie TYPE OF BIT: Back-hoe DIAMETER: NA
 SURFACE ELEVATION: Approximately -20' HAMMER WT.: N/A DROP: N/A

DEPTH	FIELD				LOG OF BORING NO. TP-2 SHEET 1 OF 1	LABORATORY		
	SAMPLE	USCS CLASS.	BLOW COUNT	POCKET PEN. (tsf)		DESCRIPTION OF MATERIAL	DRY DENSITY (pcf)	MOISTURE CONTENT (% dry wt.)
0					GRAVELLY SAND (SP): Gray, dry, coarse and fine gravels, trace cobbles at surface, loose with thin 3-4" clay layer at 5 feet below ground surface.	94.1	0.9	
5						113.4	0.6	
						NA	11.0	
					CLAY (CH): Olive brown, very moist, very stiff to hard, high plasticity.			
10					Total Depth = 6.5 ft. No groundwater encountered Backfilled with excavated soil			
15								
20								
25								
30								

DATE DRILLED: 8/31/22 TOTAL DEPTH: 6.5 Feet DEPTH TO WATER: NA
 LOGGED BY: P. LaBrucherie TYPE OF BIT: Back-hoe DIAMETER: NA
 SURFACE ELEVATION: Approximately -28' HAMMER WT.: N/A DROP: N/A

DEPTH	FIELD				LOG OF BORING NO. TP-3 SHEET 1 OF 1	LABORATORY		
	SAMPLE	USCS CLASS.	BLOW COUNT	POCKET PEN. (tsf)		DESCRIPTION OF MATERIAL	DRY DENSITY (pcf)	MOISTURE CONTENT (% dry wt.)
					GRAVELLY SAND (SP): Gray, dry, coarse and fine gravels, trace interbedded small cobbles.	105.5	1.1	c=0.20 tsf $\phi=33^\circ$
5				4.5	CLAY (CH): Olive brown, moist, very stiff to hard, high plasticity.	102.4	13.3	
					Total Depth = 6.5 ft. No groundwater encountered Backfilled with excavated soil	101.0	16.5	
10								
15								
20								
25								
30								

DATE DRILLED: 8/31/22 TOTAL DEPTH: 6.5 Feet DEPTH TO WATER: NA
 LOGGED BY: P. LaBrucherie TYPE OF BIT: Back-hoe DIAMETER: NA
 SURFACE ELEVATION: Approximately -28' HAMMER WT.: N/A DROP: N/A

PROJECT No. LE22169



PLATE B-3

DEPTH	FIELD				LOG OF BORING NO. TP-4 SHEET 1 OF 1	LABORATORY		
	SAMPLE	USCS CLASS.	BLOW COUNT	POCKET PEN. (tsf)		DESCRIPTION OF MATERIAL	DRY DENSITY (pcf)	MOISTURE CONTENT (% dry wt.)
5				4.5	SAND (SP): Surface 4", gray, dry, , trace surface cobbles.	108.2	10.5	LL=79% PI=58%
					CLAY (CH): Red-brown with black streaks, moist, very stiff to hard, high plasticity.			
					SAND (SP): 6", gray with yellows, trace fine gravels.			
					CLAY (CH): Red-brown with black streaks, moist, very stiff to hard, high plasticity.			
10					Total Depth = 6.5 ft. No groundwater encountered Backfilled with excavated soil			
15								
20								
25								
30								

DATE DRILLED: 8/31/22 TOTAL DEPTH: 6.5 Feet DEPTH TO WATER: NA
 LOGGED BY: P. LaBrucherie TYPE OF BIT: Back-hoe DIAMETER: NA
 SURFACE ELEVATION: Approximately -60' HAMMER WT.: N/A DROP: N/A

DEPTH	FIELD				LOG OF BORING NO. TP-5 SHEET 1 OF 1	LABORATORY		
	SAMPLE	USCS CLASS.	BLOW COUNT	POCKET PEN. (tsf)		DESCRIPTION OF MATERIAL	DRY DENSITY (pcf)	MOISTURE CONTENT (% dry wt.)
5				2.5	SAND (SP): Gray, dry, with coarse and fine gravels.	94.7	25.0	LL=59% PI=43%
					CLAY (CH): Red-brown with gray streaks, very moist, very stiff to hard, high plasticity.	95.7	24.6	
						96.3	23.0	
10					Total Depth = 6.5 ft. No groundwater encountered Backfilled with excavated soil			
15								
20								
25								
30								

DATE DRILLED: 8/31/22 TOTAL DEPTH: 6.5 Feet DEPTH TO WATER: NA
 LOGGED BY: P. LaBrucherie TYPE OF BIT: Back-hoe DIAMETER: NA
 SURFACE ELEVATION: Approximately -53' HAMMER WT.: N/A DROP: N/A

DEPTH	FIELD				LOG OF BORING NO. TP-6 SHEET 1 OF 1	LABORATORY		
	SAMPLE	USCS CLASS.	BLOW COUNT	POCKET PEN. (tsf)	DESCRIPTION OF MATERIAL	DRY DENSITY (pcf)	MOISTURE CONTENT (% dry wt.)	OTHER TESTS
	X				GRAVELLY SAND (SP): Gray, dry, with coarse and fine gravels.			
	X				SANDY SILT (ML): Tan, dry, with clays.	103.6	6.0	c=0.03 tsf $\phi=30^\circ$ % passing #200 = 85% <2 μ = 27%
5					CLAY (CH): Red-brown, very moist, very stiff to hard, high plasticity.	106.5	14.8	
						101.0	15.7	
10					Total Depth = 6.5 ft. No groundwater encountered Backfilled with excavated soil			
15								
20								
25								
30								

DATE DRILLED: 8/31/22 TOTAL DEPTH: 6.5 Feet DEPTH TO WATER: NA
LOGGED BY: P. LaBrucherie TYPE OF BIT: Back-hoe DIAMETER: NA
SURFACE ELEVATION: Approximately -37' HAMMER WT.: N/A DROP: N/A

PROJECT No. LE22169



PLATE B-6







DEPTH	FIELD				LOG OF BORING NO. TP-7 SHEET 1 OF 1	LABORATORY		
	SAMPLE	USCS CLASS.	BLOW COUNT	POCKET PEN. (tsf)	DESCRIPTION OF MATERIAL	DRY DENSITY (pcf)	MOISTURE CONTENT (% dry wt.)	OTHER TESTS
5	X	[Pattern]			GRAVELLY SAND (SP): Gray, dry, coarse and fine gravels, with 4-6" size cobbles.	121.4	2.2	
	X				SAND (SP): Gray, dry, some fine gravels.	104.4	2.1	c=0.14 tsf $\phi=33^\circ$
10					Total Depth = 6.5 ft. No groundwater encountered Backfilled with excavated soil			
15								
20								
25								
30								

DATE DRILLED: 8/31/22 TOTAL DEPTH: 6.5 Feet DEPTH TO WATER: NA
 LOGGED BY: P. LaBrucherie TYPE OF BIT: Back-hoe DIAMETER: NA
 SURFACE ELEVATION: Approximately -32' HAMMER WT.: N/A DROP: N/A

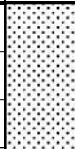
PROJECT No. LE22169

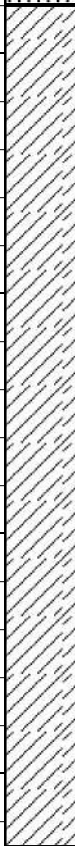

PLATE B-7







DEPTH	FIELD				LOG OF BORING NO. B-1 SHEET 1 OF 1	LABORATORY		
	SAMPLE	USCS CLASS.	BLOW COUNT	POCKET PEN. (tsf)		DESCRIPTION OF MATERIAL	DRY DENSITY (pcf)	MOISTURE CONTENT (% dry wt.)
					GRAVELLY SAND (SP): Gray, dry, coarse and fine gravels, with 4-6" size cobbles.			
5			20	4.5	CLAY (CH): Brown, very moist, very stiff to hard, high plasticity.	102.3	23.2	c=2.79 tsf LL=80% PI=58%
10			21	4.5			16.5	
15			44	4.5				
20			18	4.5				
					Total Depth = 21.5 ft. No groundwater encountered Backfilled with excavated soil			
25								
30								

DATE DRILLED: 10/12/22 TOTAL DEPTH: 21.5 Feet DEPTH TO WATER: NA
LOGGED BY: P. Santa Cruz TYPE OF BIT: Hollow Stem Auger DIAMETER: 8 in.
SURFACE ELEVATION: Approximately -59' HAMMER WT.: 140 lbs. DROP: 30 in.

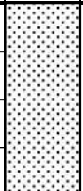
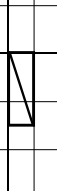
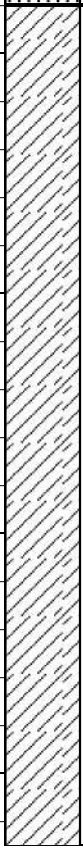
PROJECT No. LE22169

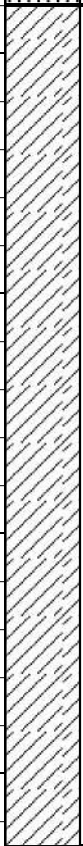

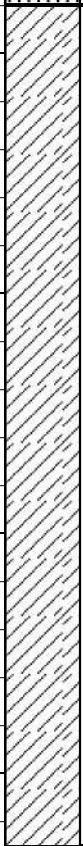
PLATE B-8

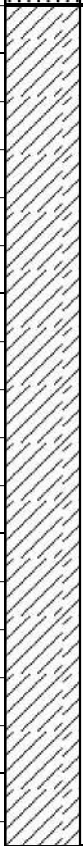
DEPTH	FIELD				LOG OF BORING NO. B-2 SHEET 1 OF 1	LABORATORY		
	SAMPLE	USCS CLASS.	BLOW COUNT	POCKET PEN. (tsf)		DESCRIPTION OF MATERIAL	DRY DENSITY (pcf)	MOISTURE CONTENT (% dry wt.)
					GRAVELLY SAND (SP): Gray, dry, coarse and fine gravels, with 4-6" size cobbles.			
5			12	4.5	CLAY (CH): Red-brown/Red-gray, very moist to wet, very stiff to hard, high plasticity.		31.1	
10			20	4.0		92.0	31.8	
15			14	4.5				
20			36	4.5				
					Total Depth = 21.5 ft. No groundwater encountered Backfilled with excavated soil			
25								
30								

DATE DRILLED: 10/12/22 TOTAL DEPTH: 21.5 Feet DEPTH TO WATER: NA
 LOGGED BY: P. Santa Cruz TYPE OF BIT: Hollow Stem Auger DIAMETER: 8 in.
 SURFACE ELEVATION: Approximately -22' HAMMER WT.: 140 lbs. DROP: 30 in.

PROJECT No. LE22169



PLATE B-9







DEPTH	FIELD				LOG OF BORING NO. B-3 SHEET 1 OF 1	LABORATORY		
	SAMPLE	USCS CLASS.	BLOW COUNT	POCKET PEN. (tsf)		DESCRIPTION OF MATERIAL	DRY DENSITY (pcf)	MOISTURE CONTENT (% dry wt.)
					CLAYEY GRAVEL/SILTY GRAVEL (GC-GM): Gray, dry, coarse and fine gravels.			% passing #4 = 45% % passing #200 = 8%
5			20	4.5	CLAY (CH): Brown, very moist, very stiff to hard, high plasticity.	95.5	26.2	c=1.04 tsf LL=60% PI=42%
10			21	4.5	CLAY (CH): Red-brown/red-gray, very moist, very stiff to hard, high plasticity.			
15			44	4.5	CLAY (CH): Gray-brown, very moist, very stiff to hard, high plasticity.		29.5	
20			18	4.5	CLAY (CH): Gray-brown, very moist, very stiff to hard, high plasticity.			
					Total Depth = 21.5 ft. No groundwater encountered Backfilled with excavated soil			

DATE DRILLED: 10/12/22 TOTAL DEPTH: 21.5 Feet DEPTH TO WATER: NA
 LOGGED BY: P. Santa Cruz TYPE OF BIT: Hollow Stem Auger DIAMETER: 8 in.
 SURFACE ELEVATION: Approximately -1' HAMMER WT.: 140 lbs. DROP: 30 in.

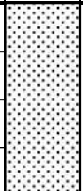
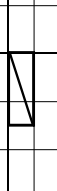
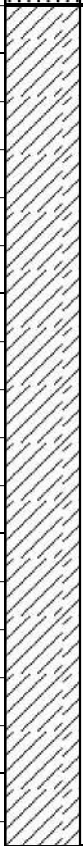
PROJECT No. LE22169

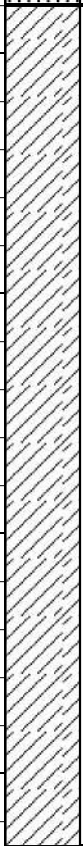

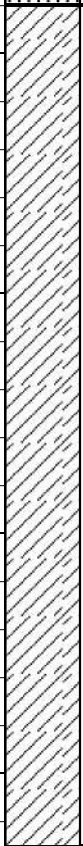
PLATE B-10

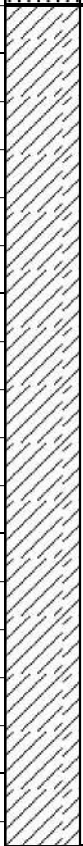
DEPTH	FIELD				LOG OF BORING NO. B-4 SHEET 1 OF 1	LABORATORY		
	SAMPLE	USCS CLASS.	BLOW COUNT	POCKET PEN. (tsf)		DESCRIPTION OF MATERIAL	DRY DENSITY (pcf)	MOISTURE CONTENT (% dry wt.)
					GRAVELLY SAND (SP): Gray, dry, coarse and fine gravels, with 4-6" size cobbles.			
5			8	3.5	CLAY (CH): Red-brown, very moist, very stiff to hard, high plasticity.		28.3	
10			22	4.5	CLAY (CH): Brown, very moist, very stiff to hard, high plasticity.	92.0	27.8	
15			12	4.5	CLAY (CH): L. brown, very moist, very stiff to hard, high plasticity.			
20			24	4.5	CLAY (CH): Red-brown, very moist, very stiff to hard, high plasticity.			
					Total Depth = 21.5 ft. No groundwater encountered Backfilled with excavated soil			
25								
30								

DATE DRILLED: 10/12/22 TOTAL DEPTH: 21.5 Feet DEPTH TO WATER: NA
 LOGGED BY: P. Santa Cruz TYPE OF BIT: Hollow Stem Auger DIAMETER: 8 in.
 SURFACE ELEVATION: Approximately -10' HAMMER WT.: 140 lbs. DROP: 30 in.

PROJECT No. LE22169



PLATE B-11

DEFINITION OF TERMS

PRIMARY DIVISIONS	SYMBOLS	SECONDARY DIVISIONS	
Coarse grained soils More than half of material is larger than No. 200 sieve	Gravels	Clean gravels (less than 5% fines)	GW Well graded gravels, gravel-sand mixtures, little or no fines
	More than half of coarse fraction is larger than No. 4 sieve	Gravel with fines	GP Poorly graded gravels, or gravel-sand mixtures, little or no fines
			GM Silty gravels, gravel-sand-silt mixtures, non-plastic fines
	Sands	Clean sands (less than 5% fines)	SW Well graded sands, gravelly sands, little or no fines
			SP Poorly graded sands or gravelly sands, little or no fines
		Sands with fines	SM Silty sands, sand-silt mixtures, non-plastic fines
SC Clayey sands, sand-clay mixtures, plastic fines			
Fine grained soils More than half of material is smaller than No. 200 sieve	Silts and clays		ML Inorganic silts, clayey silts with slight plasticity
	Liquid limit is less than 50%		CL Inorganic clays of low to medium plasticity, gravelly, sandy, or lean clays
	Liquid limit is more than 50%		OL Organic silts and organic clays of low plasticity
			MH Inorganic silts, micaceous or diatomaceous silty soils, elastic silts
	Liquid limit is more than 50%		CH Inorganic clays of high plasticity, fat clays
			OH Organic clays of medium to high plasticity, organic silts
Highly organic soils		PT Peat and other highly organic soils	

GRAIN SIZES

Silts and Clays	Sand			Gravel		Cobbles	Boulders
	Fine	Medium	Coarse	Fine	Coarse		
	200	40	10	4	3/4"	3"	12"
	US Standard Series Sieve			Clear Square Openings			

Sands, Gravels, etc.	Blows/ft. *
Very Loose	0-4
Loose	4-10
Medium Dense	10-30
Dense	30-50
Very Dense	Over 50

Clays & Plastic Silts	Strength **	Blows/ft. *
Very Soft	0-0.25	0-2
Soft	0.25-0.5	2-4
Firm	0.5-1.0	4-8
Stiff	1.0-2.0	8-16
Very Stiff	2.0-4.0	16-32
Hard	Over 4.0	Over 32

* Number of blows of 140 lb. hammer falling 30 inches to drive a 2 inch O.D. (1 3/8 in. I.D.) split spoon (ASTM D1586).

** Unconfined compressive strength in tons/s.f. as determined by laboratory testing or approximated by the Standard Penetration Test (ASTM D1586), Pocket Penetrometer, Torvane, or visual observation.

Type of Samples:

Ring Sample
 Standard Penetration Test
 Shelby Tube
 Bulk (Bag) Sample

Drilling Notes:

1. Sampling and Blow Counts
 - Ring Sampler - Number of blows per foot of a 140 lb. hammer falling 30 inches.
 - Standard Penetration Test - Number of blows per foot.
 - Shelby Tube - Three (3) inch nominal diameter tube hydraulically pushed.
2. P. P. = Pocket Penetrometer (tons/s.f.).
3. NR = No recovery.
4. GWT = Ground Water Table observed @ specified time.

LANDMARK

Geo-Engineers and Geologists

Project No. LE22169

Key to Logs

Plate
B-12

APPENDIX C

LANDMARK CONSULTANTS, INC.

CLIENT: Apex Energy
PROJECT: NorthStar 1 Solar
JOB No.: LE22169
DATE: 10/24/22

ATTERBERG LIMITS (ASTM D4318)

Sample Location	Sample Depth (ft)	Liquid Limit (LL)	Plastic Limit (PL)	Plasticity Index (PI)	USCS Classification
T-4	1-4	79	21	58	CH
T-5	1-5	59	16	43	CH
B-1	5	80	22	58	CH
B-3	5	60	18	42	CH

PLASTICITY CHART

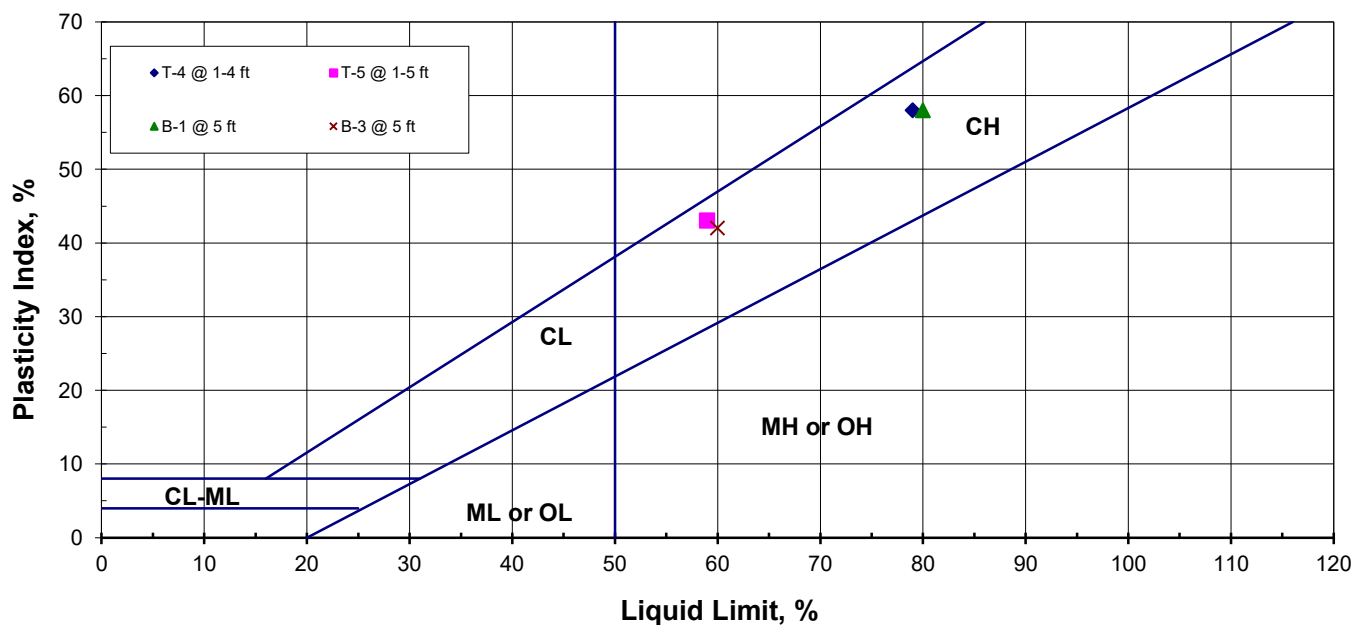

Project No.: LE22169

**Atterberg Limits
Test Results**

**Plate
C-1**

SIEVE ANALYSIS					HYDROMETER ANALYSIS
Gravel		Sand			Silt and Clay Fraction
Coarse	Fine	Coarse	Medium	Fine	

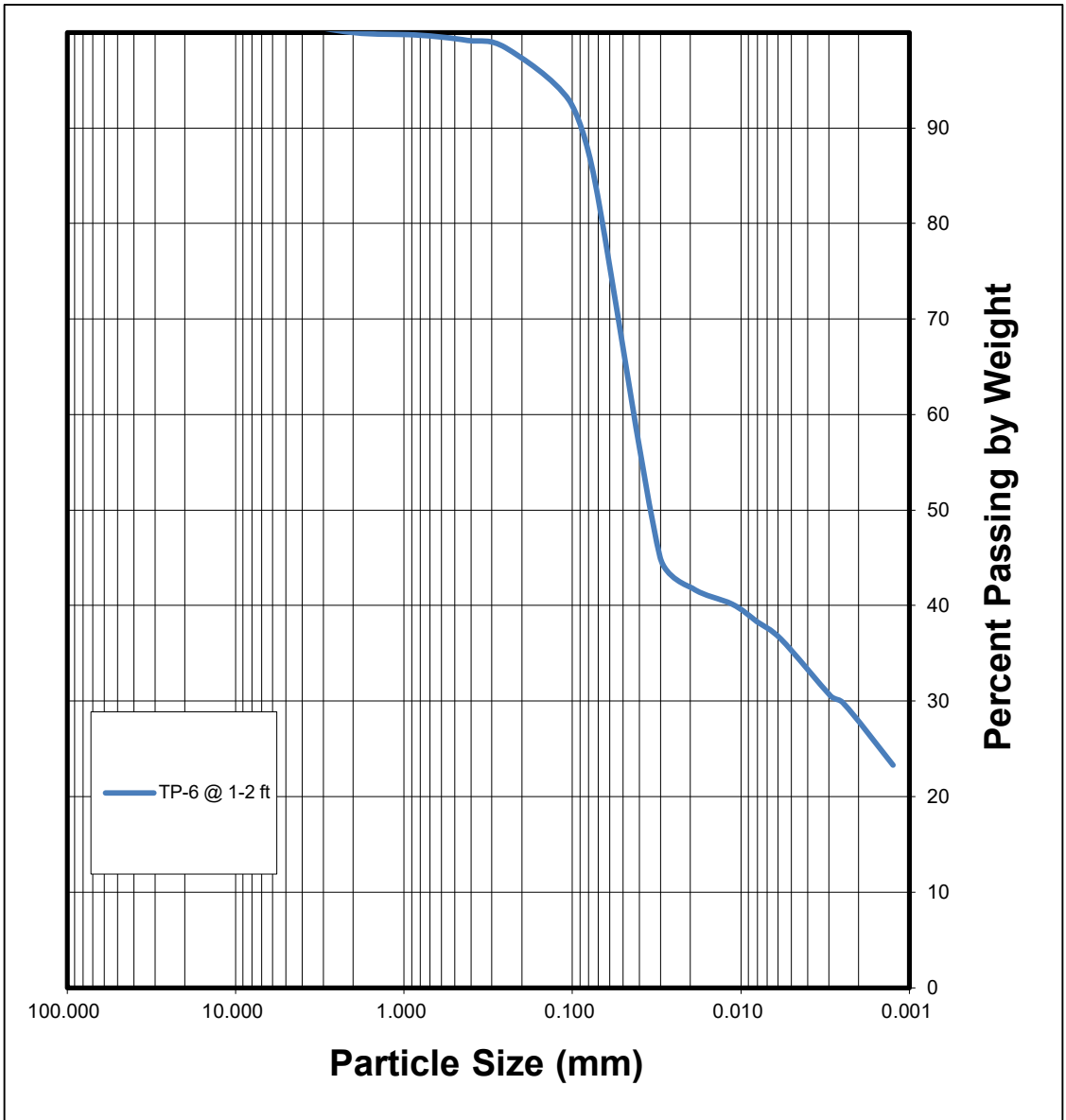

LANDMARK
Geo-Engineers and Geologists

Project No.: LE22169

Grain Size Analysis

Plate
C-2

SIEVE ANALYSIS				HYDROMETER ANALYSIS		
Gravel		Sand			Silt and Clay Fraction	
Coarse	Fine	Coarse	Medium	Fine		

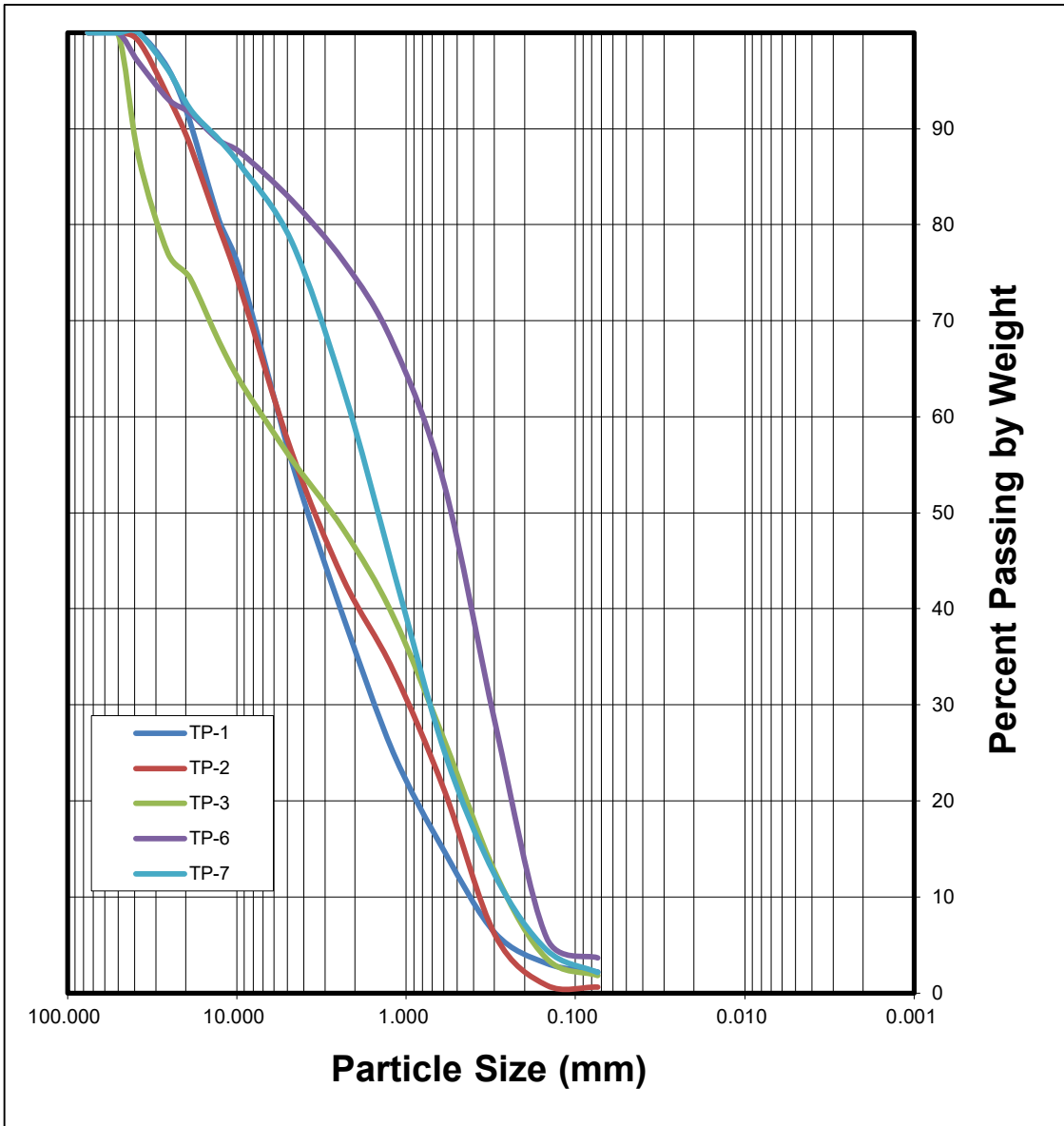

LANDMARK
Geo-Engineers and Geologists
Project No.: LE22169

Grain Size Analysis

**Plate
C-3**

SIEVE ANALYSIS				HYDROMETER ANALYSIS	
Gravel		Sand			Silt and Clay Fraction
Coarse	Fine	Coarse	Medium	Fine	

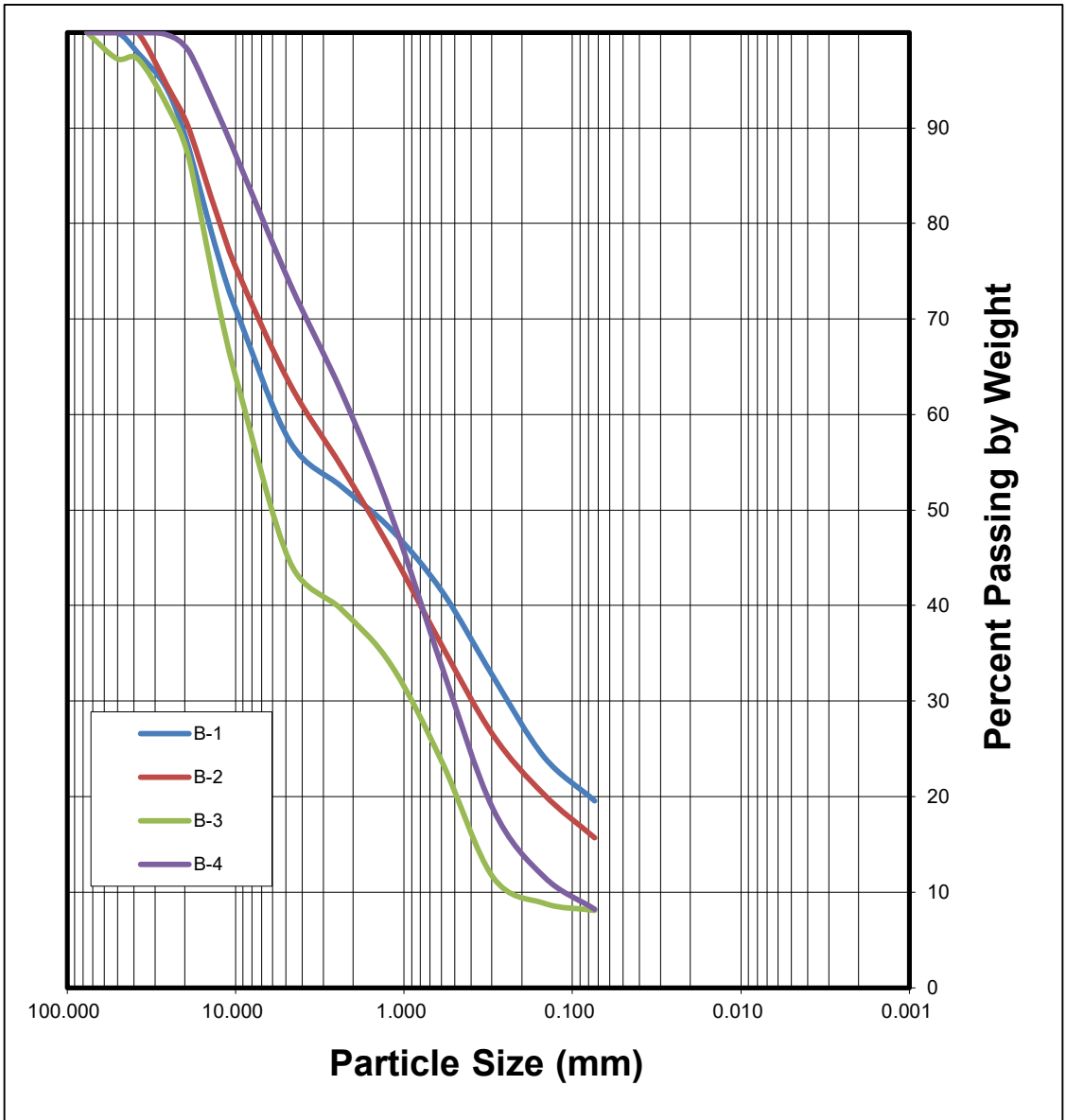

LANDMARK
Geo-Engineers and Geologists

Project No.: LE22169

Grain Size Analysis

Plate
C-4

LANDMARK CONSULTANTS, INC.

CLIENT: Apex Energy Solutions, LLC
PROJECT: NorthStar 1 Solar Project, Niland, CA
JOB NO: LE22169
DATE: 10/18/2022

UNCONFINED COMPRESSION TEST (ASTM D2166)

Boring No.	Sample Depth (ft)	Natural Moisture Content (%)	Unit Dry Weight (pcf)	Maximum Compressive Strength (tsf)	Cohesion (tsf)	Failure Strain (%)
B-1	5	23.2	102.3	5.57	2.79	2.7
B-3	5	26.2	95.5	2.09	1.04	21.9

Stress - Strain Plot

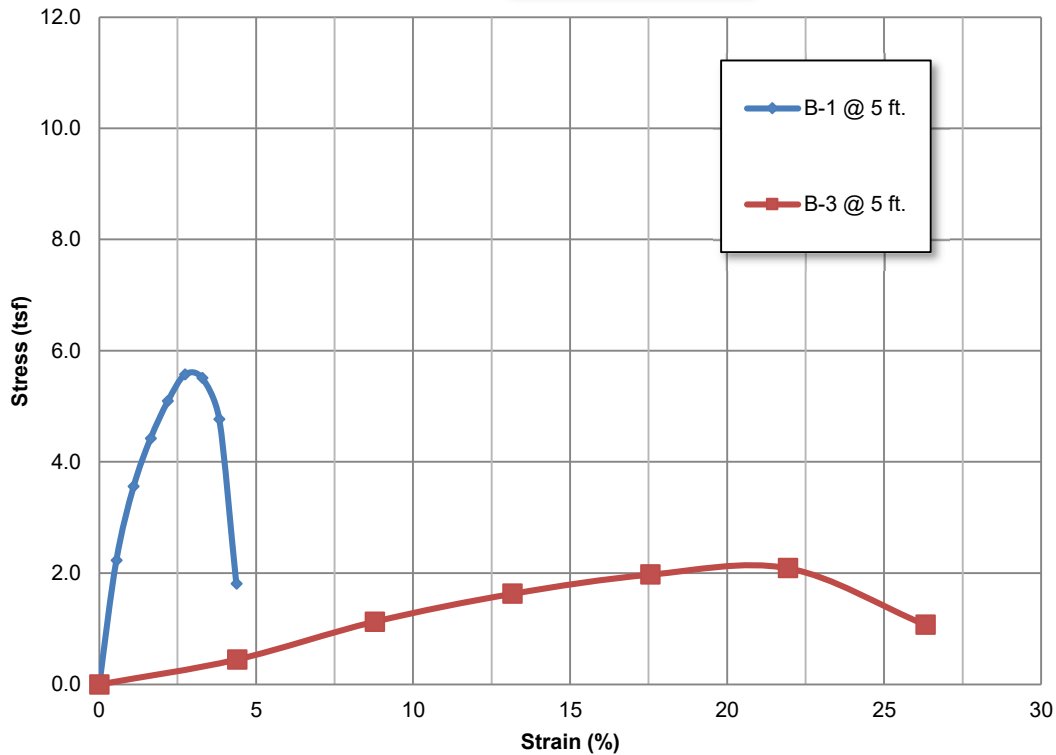

Project No.: LE22169

Unconfined Compression
Test Results

Plate
C-5

LANDMARK CONSULTANTS, INC.

CLIENT: Apex Energy Solutions, LLC
PROJECT: NorthStar 1 Solar Project, Niland, CA
PROJECT No: LE22169 **DATE:** 10/19/2022

DIRECT SHEAR TEST - INSITU (ASTM D3080)

SAMPLE LOCATION: T-3 @ 0-2 ft
SAMPLE DESCRIPTION: Silty Sand (SM)

Angle of Internal Friction: 33° **Initial Dry Density:** 106.4 pcf
Cohesion: 0.4 ksf **Initial Moisture Content:** 0.3%

DIRECT SHEAR TEST RESULTS

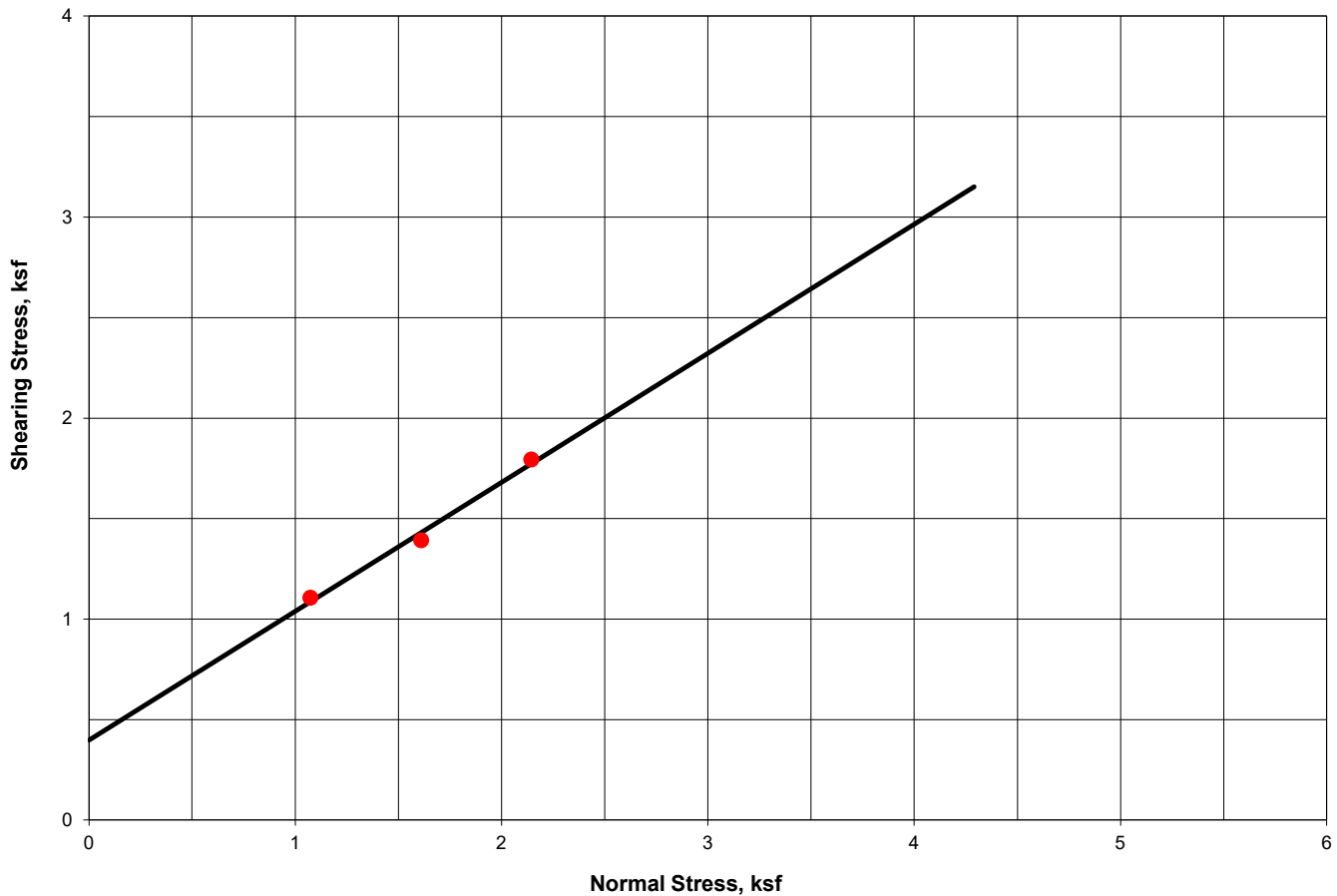

LANDMARK
Geo-Engineers and Geologists

PROJECT No: LE22169

Direct Shear Test Results

**Plate
C-6**

LANDMARK CONSULTANTS, INC.

CLIENT: Apex Energy Solutions, LLC
PROJECT: NorthStar 1 Solar Project, Niland, CA
PROJECT No: LE22169 **DATE:** 10/19/2022

DIRECT SHEAR TEST - INSITU (ASTM D3080)

SAMPLE LOCATION: T-6 @ 1-2 ft
SAMPLE DESCRIPTION: Clayey Sand (SC)

Angle of Internal Friction: 30° **Initial Dry Density:** 103.6 pcf
Cohesion: 0.06 ksf **Initial Moisture Content:** 6.1%

DIRECT SHEAR TEST RESULTS

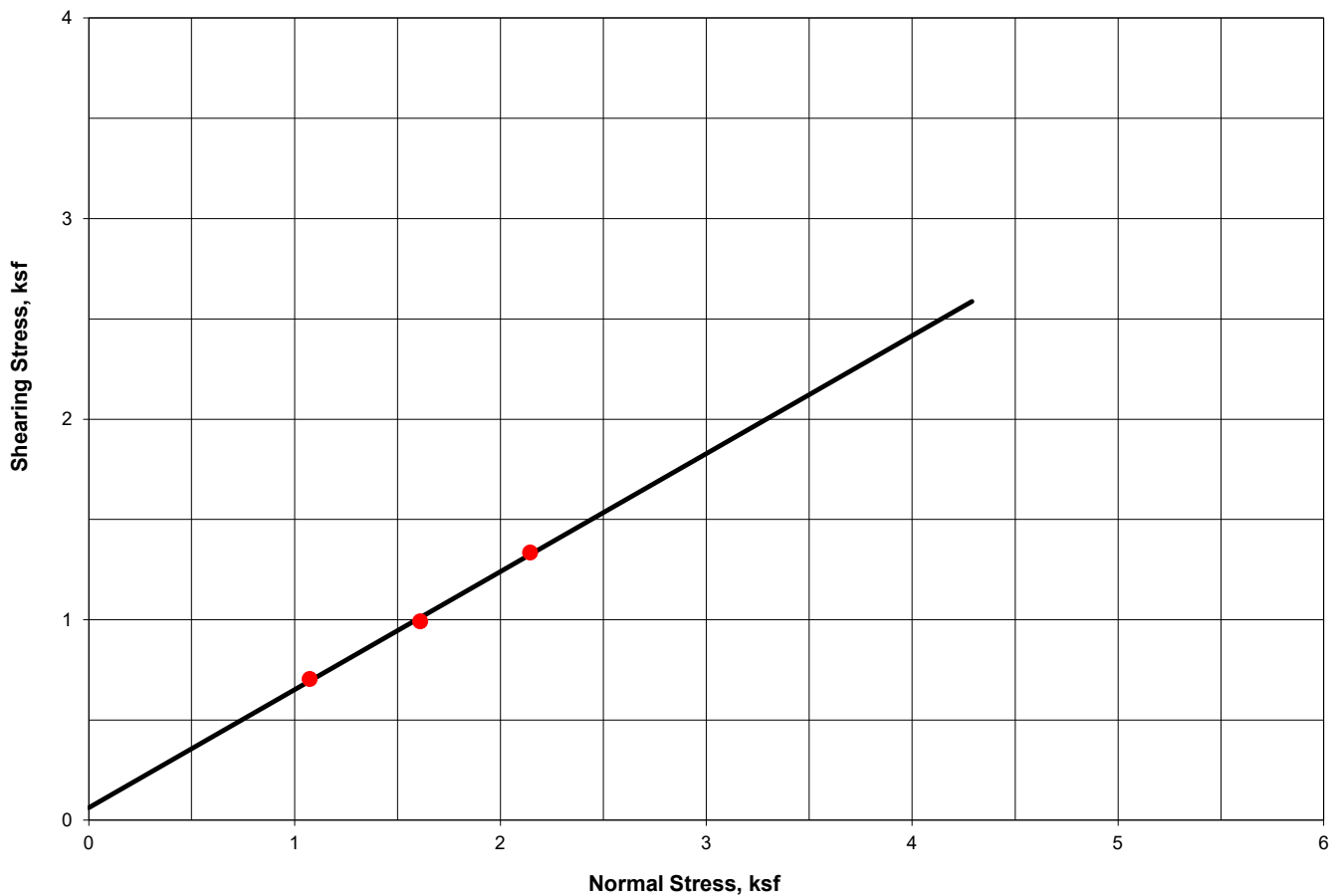

LANDMARK CONSULTANTS, INC.

CLIENT: Apex Energy Solutions, LLC
PROJECT: NorthStar 1 Solar Project, Niland, CA
PROJECT No: LE22169 **DATE:** 10/19/2022

DIRECT SHEAR TEST - INSITU (ASTM D3080)

SAMPLE LOCATION: T-7 @ 6 ft
SAMPLE DESCRIPTION: Gravelly Sand (SP)

Angle of Internal Friction: 33° **Initial Dry Density:** 105.1 pcf
Cohesion: 0.28 ksf **Initial Moisture Content:** 1.4%

DIRECT SHEAR TEST RESULTS

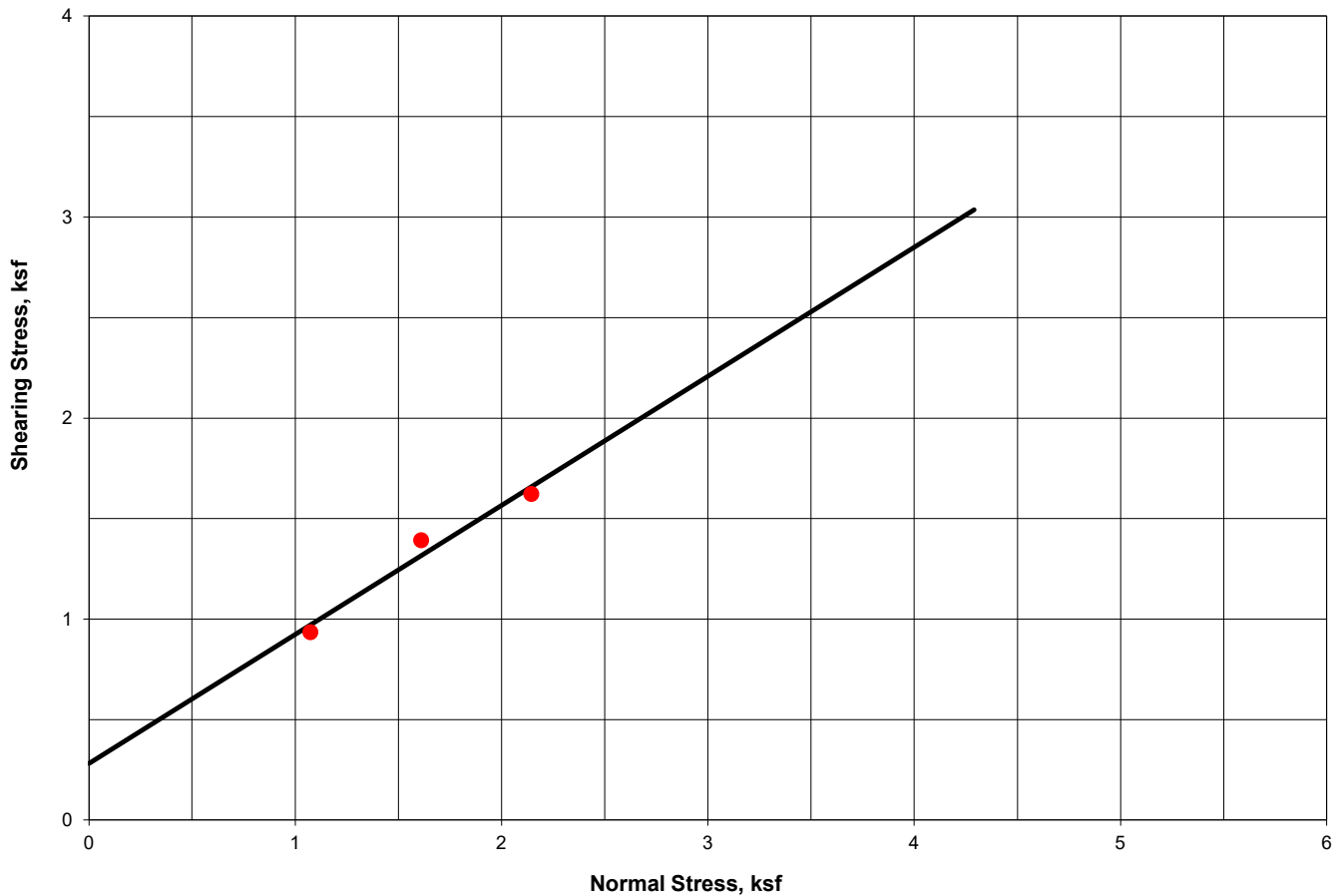

LANDMARK
Geo-Engineers and Geologists

PROJECT No: LE22169

Direct Shear Test Results

Plate
C-8

APPENDIX D

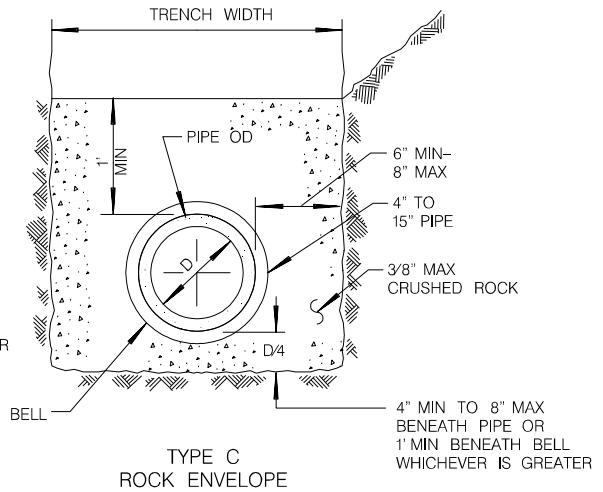
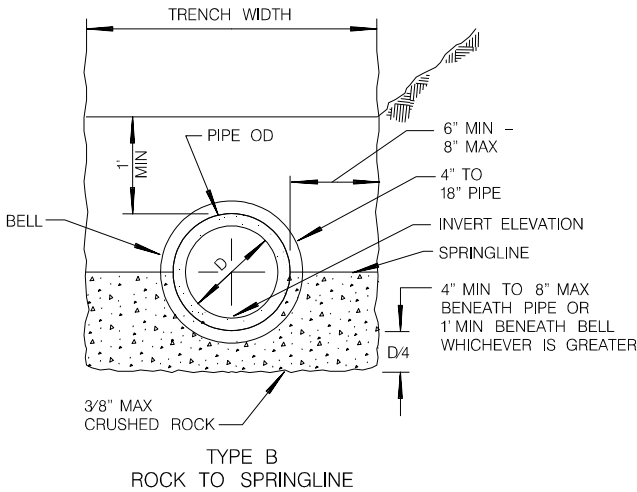
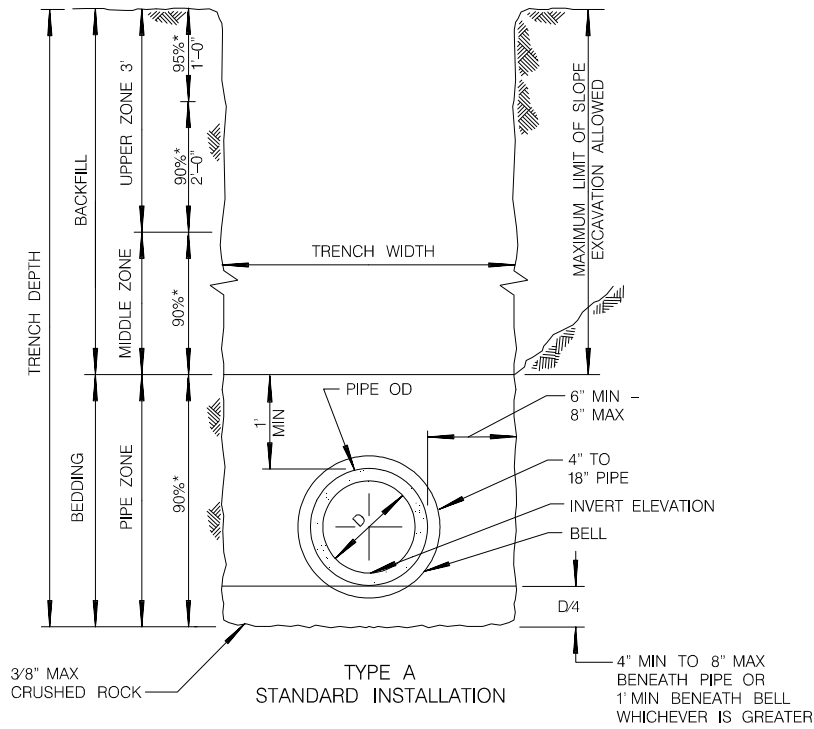

NOTES

1. FOR TRENCH RESURFACING IN IMPROVED STREETS, SEE STANDARD DRAWINGS SDG-107 AND SDG-108.
2. (*) INDICATES MINIMUM RELATIVE COMPACTION.
3. MINIMUM DEPTH OF COVER FROM THE TOP OF PIPE TO FINISH GRADE FOR PVC SDR 35 SEWER MAIN SHALL BE 5'. FOR SHALLOWER DEPTH, SPECIAL DESIGN IS REQUIRED. SEE SDS-101.
4. SEE TYPE A INSTALLATION FOR DETAILS NOT SHOWN FOR TYPES B AND C.
5. FOR PIPE SIZE ENCASEMENT LARGER THAN 15", MAXIMUM SIDE WALL CLEARANCE SHALL BE 12" OR AS SHOWN ON THE PLANS.
6. 6" METAL TAPE SHALL BE INSTALLED ABOVE PIPE 4" BELOW TRENCH CAP AND 12" BELOW FINISH GRADE IN UNIMPROVED STREETS.
7. 1" SAND CUSHION OR A 6" MINIMUM SAND CUSHION WITH 1" NEOPRENE PAD SHALL BE PLACED FOR CROSSINGS UTILITIES WHEN VERTICAL CLEARANCE IS 1' OR LESS. THE NEOPRENE PAD SHALL BE PLACED ON THE MOST FRAGILE UTILITY.

From: City of San Diego Standard Drawing SDS-110 (2016)

LANDMARK
Geo-Engineers and Geologists
Project No.: LE22169

**Pipe Bedding and Trench Backfill
Recommendations**

**Plate
D-1**

APPENDIX E

**NORTHSTAR SOLAR – SITE LE22169
SOIL ASSESSMENT SUMMARY REPORT**

Presented To:

Landmark Consultants

Prepared by:

R. F. Yeager
E N G I N E E R I N G

Project No. 22136

SEPTEMBER 23, 2022

INTRODUCTION

RFYeager Engineering has completed an electrical and thermal resistivity assessment at the proposed Site LE22169 of the NorthStar Solar Project, north of Niland, California. A chemical analysis of three (3) soil samples provided by Landmark was also conducted. The objective of this study is to determine the thermal and electrical resistivity, as well as to determine the corrosivity of the soil at the project site.

The location and numbering of the assessment sites is shown in Figure 1 at the end of this report. Figure 1 is based upon the site map provided by Landmark.

SCOPE

The electrical resistivity of the soil was determined by using the Wenner 4 pin method in accordance with ASTM G57 standards. Six readings were obtained and recorded for each assessment site based upon pin spacings of 40, 20, 15, 10, 5, and 2.5 feet. Readings were recorded at three locations within the LE22169 boundaries. All resistivity readings were recorded utilizing a Soil Resistance Meter (Megger Model DET4T2).

The soil corrosivity was evaluated based on the results of the field soil electrical resistivity assessment and the chemical analyses of the three soil samples. The soil samples were obtained by Landmark from a depth of approximately 3 feet. The samples were analyzed for pH, soluble salts (chlorides and sulfates) as well as resistivity in the saturated condition.

The thermal resistivity was determined using a Decagon KD2 Pro Portable Thermal Properties Analyzer (KD2 Pro) outfitted with the 100 mm long, 2.4 mm diameter TR-1 sensor. The KD2 Pro works in accordance with ASTM D5334-08 using a transient heat method.

CONCLUSIONS

The following are significant conclusions resulting from this assessment:

1. The results of the field electrical resistivity assessment are provided in Table 1. Resistivity readings ranging from 1,149 ohm-cm to 58,408 ohm-cm. It is noted that the dry, loose soil conditions at several locations made it challenging to obtain accurate field data. Large amounts of water had to be poured at each pin location in order to achieve sufficient electrical contact with the earth.

Table 1 – NorthStar Solar Site LE22169 Soil Electrical Resistivity Data Prepared by: RFYeager Engineering Test Date: 8.31.2022							
Test No.	Assessment Site ID	Soil Resistivity (Ohm-cm)					
		Ave. Soil Depth (feet)					
		40	20	15	10	5	2.5
1	ER-1	18384	34087	44524	40407	42513	58408
2	ER-2	2681	3102	3820	4022	5649	7804
3	ER-3	1149	1226	1379	2107	2202	2820

1 - See Figure 1 for soil assessment location relative to project site

2. The soil sample chemical analysis results were varied (see Table 2). The saturated soil resistivity of Sample 1 was 2,200 ohm-cm. The saturated soil resistivity of Samples 2 and 3, were much lower at 53 ohm-cm and 140 ohm-cm, respectively. Sample 1 contained relatively low concentrations of chlorides (i.e. less than 300 ppm) and sulfates (i.e. less than 1000 ppm). Samples 2 and 3 contained appreciably higher concentrations of soluble salts which is consistent with the measured low saturated soil resistivity. The pH readings for all soil samples are indicative of slightly alkaline soil conditions.

Table 2 – NorthStar Solar Site LE22169 Chemical Analysis Data Prepared by: RFYeager Engineering				
Sample ID ¹	Min. Soil Box Resistivity ² (ohm-cm)	Chloride Concentration ³ (ppm)	Sulfate Concentration ⁴ (ppm)	pH ⁵
1	2,200	130	40	8.3
2	53	8,860	410	7.4
3	140	2,190	120	7.7

1 - See Figure 1 for soil sample location. Soil sample taken from a depth of 3 feet

2 - Min. Electrical Resistivity - Miller Soil Box Method, Cal. Test 643

3 - Soluble Soil Chlorides - Cal. Test 422

4 - Soluble Sulfate Content - Cal. Test 417

5 - pH - Cal. Test 643

3. It is noted that the saturated soil box resistivities measured from the three soil samples are lower than the Wenner 4-pin resistivities taken in the field. This is likely due to the relatively dry soil conditions at the project site during the field assessment. The dryer the soil, the lesser the impact soluble soil salts have on resistivity. The saturated (minimum) soil box measurements represent the lowest, most corrosive conditions whereby the soils become fully saturated and have the lowest resistivity.

4. The results of the field electrical resistivity assessment and soil sample analysis at the Project's Site LE22169 indicate varying levels of soil corrosivity. However, for all locations, the soil is considered aggressive enough to initiate and support the corrosion of buried metallic utilities. This conclusion is based primarily on the relatively low saturated soil box resistivities, as well as the high soluble salt concentrations at 2 of the 3 test sites. Accordingly, supplemental corrosion control measures are recommended in order to prevent premature failures.

5. The soil thermal resistivity is provided in Table 3 on the following page. The corresponding Time vs. Temperature graphs for each assessment site is provided in Appendix A.

Table 3 – NorthStar Solar Site LE22169	
Thermal Resistivity Data	
Prepared by: RFYeager Engineering	
Sample ID¹	In-Situ Thermal Resistivity² (m °CW⁻¹)
TR1	3.04
TR2	1.14
TR3	0.94

1 - See Figure 1 for sample location relative to project site

2 – ASTM D5334-08.

DISCUSSION

Electrical Resistivity Assessment

Soil electrical resistivity (inverse of conductivity) measures the ability of an electrolyte (soil) to support electrical current flow. The most common method of measuring soil electrical resistivity is the Wenner 4-Pin Method which uses four pins (electrodes) that are driven into the earth and equally spaced apart in a straight line. The Wenner 4-pin Method provides an average resistivity of a hemisphere (essentially) of soil whose diameter is approximately equal to the pin spacing.

For example, the electrical resistivity value obtained with the pins spaced at 5 feet apart is the average resistivity of a hemisphere of soil from the surface to a depth of 5 feet. By taking readings at different pin spacings (or depths), average soil electrical resistivity conditions can be obtained within areas at, above, and below trench zones.

Corrosion versus Resistivity

Corrosion is an electrochemical process, whereby the reaction rate is largely dependent upon the electrical conductivity of the surrounding electrolyte. Accordingly, the lower the electrical resistivity, then the greater the current flow and the greater the corrosion rate assuming all other factors are equal.

One common relationship between corrosivity and soil electrical resistivity used by corrosion engineers is provided on the following page.

<u>Corrosivity</u>	<u>Electrical Resistivity</u>
Very Corrosive	0-1000 ohm-cm
Corrosive	1001-2000 ohm-cm
Fairly Corrosive	2001-5000 ohm-cm
Moderately Corrosive	5001-12000 ohm-cm
Slightly Corrosive	12001-30000 ohm-cm
Relatively Non-Corrosive	Greater than 30001 ohm-cm

Thermal Resistivity Assessment

Thermal resistivity of the soil was measured at three locations selected by Landmark within the LE22169 Project site. Assessments were conducted at within test pits at a depth of approximately 2 feet. At each site, the thermal resistivity was measured three times with the average provided in Table 3. The assessment was conducted in general accordance with the standard method ASTM D5334-08 which calculates thermal resistivity by monitoring the dissipation of heat from a line heat source. The field assessment consists of inserting a thermal sensor into the soil with a known current and voltage applied. The corresponding temperature rise in the soil over a period of time is recorded. The thermal resistivity is obtained from an analysis of the time series temperature data during the heating and cooling cycle of the sensor. For purposes of this report, the thermal resistivity values are provided as “data only” in order to assist others in the project design.

Thank you for this opportunity to provide these corrosion engineering services. Please contact me if you have any questions.



Randy J. Geving, PE
Registered Professional Engineer – Corrosion No.1060
RGeving@RFYeager.com, 760.715.2358

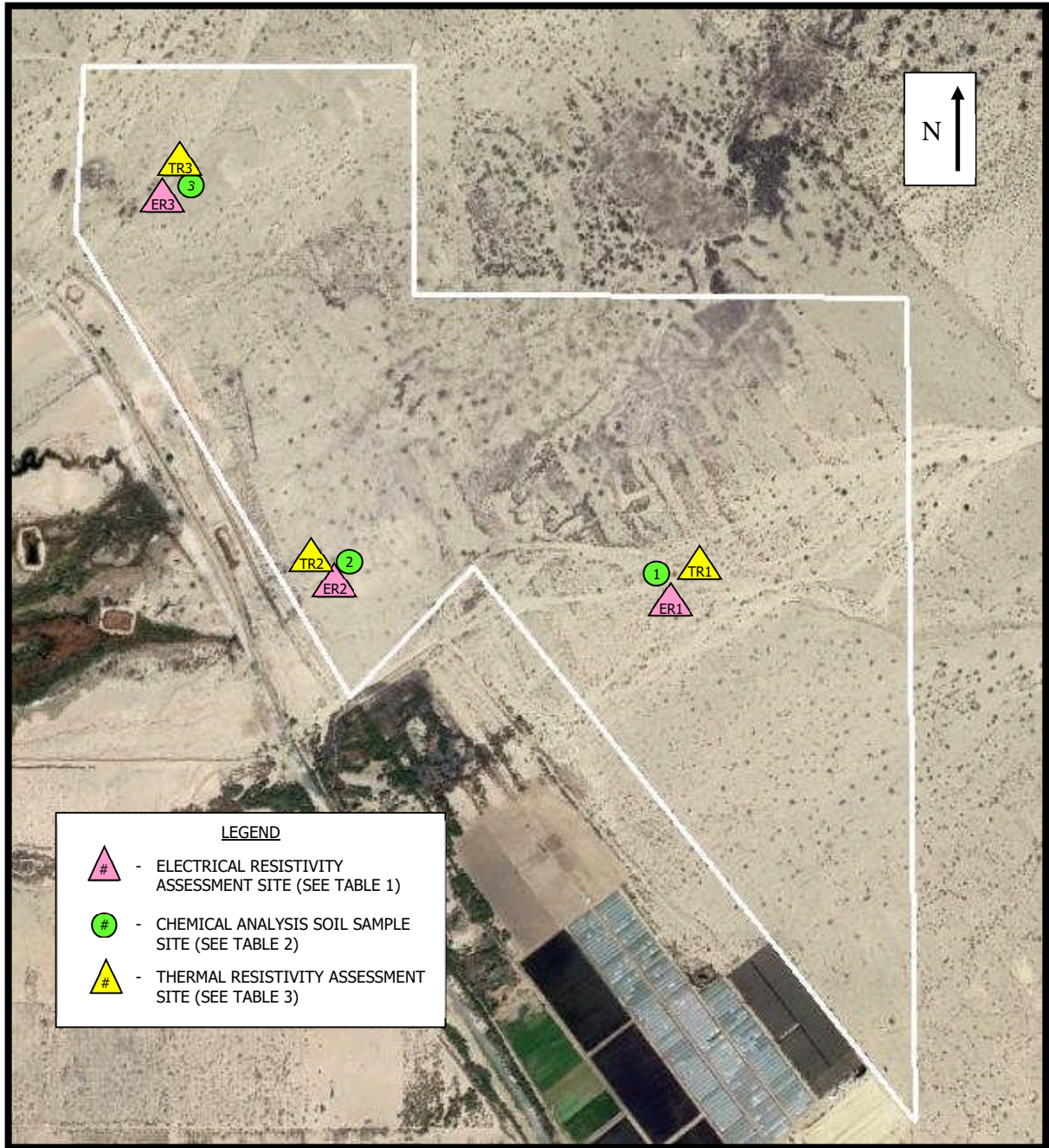
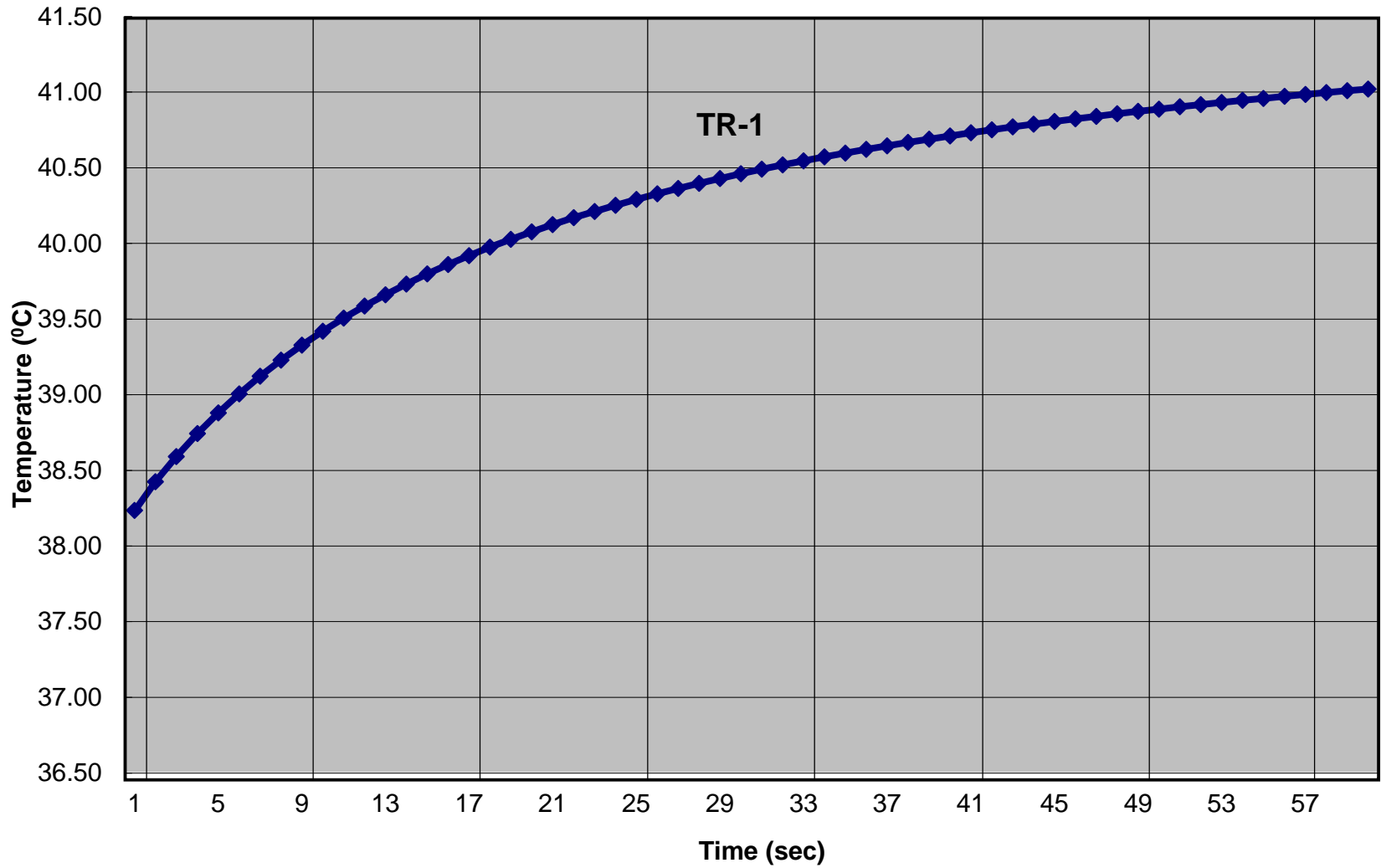

Figure 1 – NorthStar Solar Site LE22169 Assessment Locations

APPENDIX A
THERMAL RESISTIVITY
TEMPERATURE VS. TIME GRAPHS

NorthStar Solar - Site LE22169
Thermal Resistivity Temperature vs. Time Graph
Test Date: August 31, 2022



RFYeager Engineering

NorthStar Solar - Site LE22169
Thermal Resistivity Temperature vs. Time Graph
Test Date: August 31, 2022

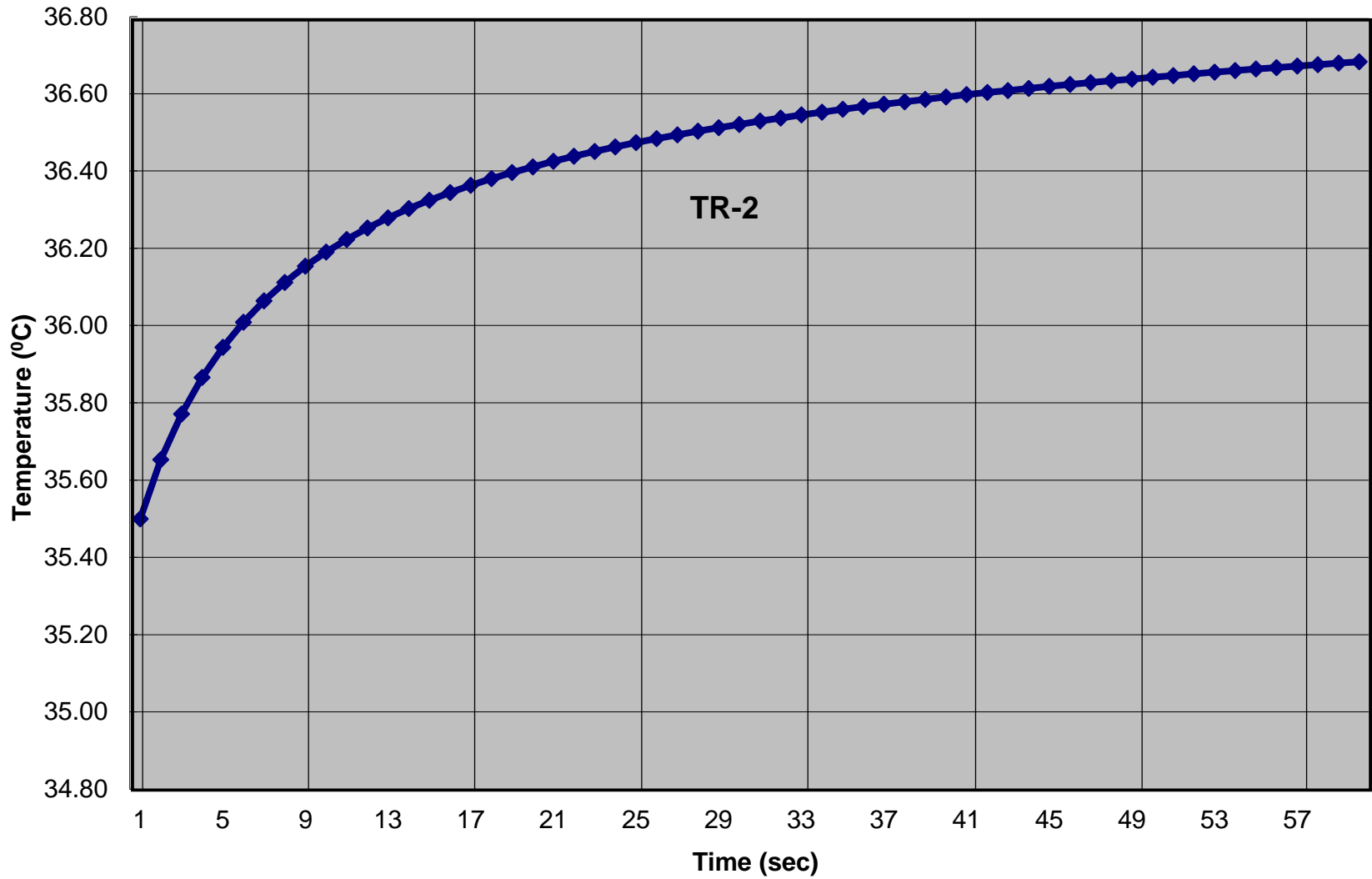

RFYeager Engineering

NorthStar Solar - Site LE22169
Thermal Resistivity Temperature vs. Time Graph
Test Date: August 31, 2022

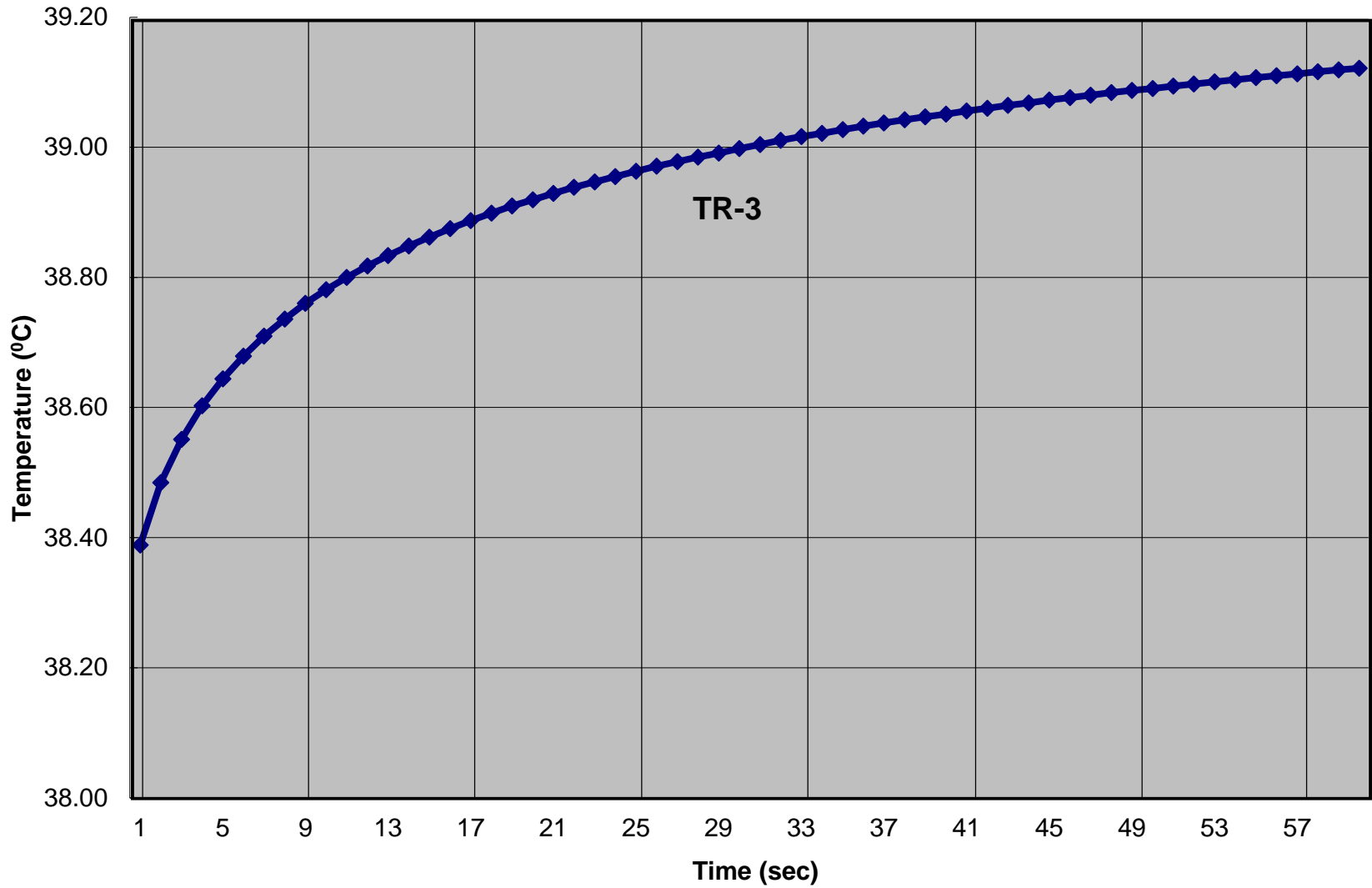

RFYeager Engineering

APPENDIX F

REFERENCES

- American Concrete Institute (ACI), 2013, ACI Manual of Concrete Practice 302.1R-04
- American Society of Civil Engineers (ASCE), 2010, Minimum Design Loads for Buildings and Other Structures: ASCE Standard 7-10.
- California Building Standards Commission, 2017, 2016 California Building Code. California Code of Regulations, Title 24, Part 2, Vol. 2 of 2.
- Caltrans, 2012, Highway Design Manual.
- California Division of Mines and Geology (CDMG), 1996, California Fault Parameters: available at <http://www.consrv.ca.gov/dmg/shezp/ftindex.html>.
- California Geological Survey (CGS), 2008, Guidelines for Evaluating and Mitigating Seismic Hazards in California, Special Publication 117A, 98p.
- California Geological Survey (CGS), 2018, Fault Activity Map of California <http://www.quake.ca.gov/gmaps/FAM/faultactivitymap.html#>.
- California Geological Survey (CGS), 2018, Alquist-Priolo Earthquake Fault Zone Maps. <http://maps.conservation.ca.gov/cgs/informationwarehouse/index.html?map=regulatorymaps>
- Cetin, K. O., Seed, R. B., Der Kiureghian, A., Tokimatsu, K., Harder, L. F., Jr., Kayen, R. E., and Moss, R. E. S., 2004, Standard penetration test-based probabilistic and deterministic assessment of seismic soil liquefaction potential: ASCE JGGE, Vol., 130, No. 12, p. 1314-1340.
- Geologismiki, 2017, CLiq Computer Program, www.geologismiki.gr
- Ishihara, K. (1985), Stability of natural deposits during earthquakes, Proc. 11th Int. Conf. On Soil Mech. And Found. Engrg., Vol. 1, A. A. Balkema, Rotterdam, The Netherlands, 321-376.
- Jones, A. L., 2003, An Analytical Model and Application for Ground Surface Effects from Liquefaction, PhD. Dissertation, University of Washington, 362 p.
- McCrink, T. P., Pridmore, C. L., Tinsley, J. C., Sickler, R. R., Brandenburg, S. J., and Stewart, J. P., 2011, Liquefaction and Other Ground Failures in Imperial County, California, from the April 4, 2010, El Mayor—Cucapah Earthquake, CGS Special Report 220, USGS Open File Report 2011-1071, 84 p.

- Morton, P. K., 1977, Geology and mineral resources of Imperial County, California: California Division of Mines and Geology, County Report No. 7, 104 p.
- Post-Tensioning Institute (PTI), 2007a, Standard Requirements for Analysis of Shallow Concrete Foundations on Expansive Soils (3rd Edition).
- Post-Tensioning Institute (PTI), 2007b, Standard Requirements for Design of Shallow Post-Tensioned Concrete Foundations on Expansive Soils (2nd Edition).
- Robertson, P. K., 2014, Seismic liquefaction CPT-based methods: EERI 1st Workshop on Geotechnical Earthquake Engineering – Liquefaction Evaluation, Mapping, Simulation and Mitigation. UC San Diego Campus, 10/12/2014.
- Robertson, P. K. and Wride, C. E., 1997, Cyclic Liquefaction and its Evaluation based on the SPT and CPT, Proceeding of the NCEER Workshop on Evaluation of Liquefaction Resistance of Soils, NCEER Technical Report 97-0022, p. 41-88.
- Rymer, M.J., Treiman, J.A., Kendrick, K.J., Lienkaemper, J.J., Weldon, R.J., Bilham, R., Wei, M., Fielding, E.J., Hernandez, J.L., Olson, B.P.E., Irvine, P.J., Knepprath, N., Sickler, R.R., Tong, .X., and Siem, M.E., 2011, Triggered surface slips in southern California associated with the 2010 El Mayor-Cucapah, Baja California, Mexico, earthquake: U.S. Geological Survey Open-File Report 2010-1333 and California Geological Survey Special Report 221, 62 p., available at <http://pubs.usgs.gov/of/2010/1333/>.
- U.S. Geological Survey (USGS), 1990, The San Andreas Fault System, California, Professional Paper 1515.
- U.S. Geological Survey (USGS), 2017, US Seismic Design Maps Web Application, available at <http://geohazards.usgs.gov/designmaps/us/application.php>
- Wire Reinforcement Institute (WRI/CRSI), 2003, Design of Slab-on-Ground Foundations, Tech Facts TF 700-R-03, 23 p.
- Youd, T. L., 2005, Liquefaction-induced flow, lateral spread, and ground oscillation, GSA Abstracts with Programs, Vol. 37, No. 7, p. 252.
- Youd, T. L. and Garris, C. T., 1995, Liquefaction induced ground surface disruption: ASCE Geotechnical Journal, Vol. 121, No. 11.
- Zimmerman, R. P., 1981, Soil survey of Imperial County, California, Imperial Valley Area: U.S. Dept. of Agriculture Soil Conservation Service, 112 p.

Energy Consumption Assessment for the North Star 1 Project

County of Imperial, California

Prepared For:

ZGlobal, Inc.
604 Sutter Street, Suite 250
Folsom, California 95630

Prepared By:



ECORP Consulting, Inc.
ENVIRONMENTAL CONSULTANTS

2525 Warren Drive
Rocklin, California 95677

February 28, 2023

CONTENTS

1.0	INTRODUCTION	1
1.1	Project Overview.....	1
1.2	Project Location and Description.....	1
1.3	Project Construction	1
2.0	ENERGY CONSUMPTION.....	4
2.1	Energy Types and Sources.....	4
2.1.1	Energy Consumption	4
2.2	Regulatory Framework.....	6
2.2.1	State.....	6
2.2.2	Renewable Energy Sources (Renewable Portfolio Standards).....	6
2.3	Energy Consumption Impact Assessment.....	7
2.3.1	Thresholds of Significance	7
2.3.2	Methodology	7
2.3.3	Impact Analysis.....	8
3.0	REFERENCES.....	10

LIST OF TABLES

Table 1.	Electricity Consumption in Imperial County 2016 – 2020.....	4
Table 2.	Natural Gas Consumption in Imperial County 2016-2020.....	5
Table 3.	Automotive Fuel Consumption in Imperial County 2016-2021.....	5
Table 4.	Proposed Project Energy and Fuel Consumption.....	8

LIST OF FIGURES

Figure 1.	Project Regional Map.....	2
Figure 2.	Project Vicinity Map.....	3

LIST OF APPENDICES

Appendix A - Energy Consumption Modeling Output

LIST OF ACRONYMS AND ABBREVIATIONS

Term	Definition
CalEEMod	California Emissions Estimator Model
CAISO	California Independent System Operator
CARB	California Air Resources Board
CEC	California Energy Commission
CPUC	California Public Utilities Commission
EO	Executive Order
IID	Imperial
kWh	Kilowatt-Hours
MW	Megawatt
MWh	Megawatt Hour
PV	Photovoltaic
Project	North Star 1 Project
RPS	Renewables Portfolio Standard
SB	Senate Bill

1.0 INTRODUCTION

This report documents the results of an Energy Impact Assessment completed for the North Star 1 Project (Project), which includes the construction of a nominal 50-megawatt (MW) alternating current solar photovoltaic (PV) energy generation system with an integrated 75 MW battery storage system spanning approximately 287 acres of land in the County of Imperial, California. This report was prepared to analyze the potential direct and indirect environmental impacts associated with Project energy consumption, including the depletion of nonrenewable resources (e.g., oil, natural gas, coal) during the construction and operational phases. The impact analysis focuses on the four sources of energy that are relevant to the Proposed Project: electricity, natural gas, the equipment-fuel necessary for Project construction, and the automotive fuel necessary for Project operations.

1.1 Project Overview

The Project proposes to construct a nominal 50 MW alternating current PV energy generation system, accompanied by a 75 MW battery storage, utilizing either thin film or crystalline solar PV technology modules mounted either on horizontal single-axis tracker systems. The PV module arrays would be mounted on racks that would be supported by driven piles. The individual PV systems would be arranged in large arrays by placing them in columns spaced approximately 10 feet apart to maximize operational performance and to allow access for panel cleaning and maintenance. Operational water supply for the Project would be trucked in from offsite over the life of the Project.

1.2 Project Location and Description

The total combined Project Site spans approximately 287 acres and is located 6.1 miles north of the unincorporated community of Niland, and approximately 8.2 miles east of the community of Bombay Beach, between the East Highline Canal and Coachella Canal (Figures 1 and 2). The irregular shaped site is bound by vacant desert lands to the west, north, and east, and agricultural land to the south. The Project Site is currently characterized by flat and undeveloped desert landscape.

1.3 Project Construction

Construction activities would involve site preparation and grubbing, grading of the Project Area to establish access roads and pads for electrical equipment (inverters and step-up transformers), trenching for underground electrical collection lines, and the installation of solar equipment and security fencing. The construction of the Project is estimated to take approximately 12 months. A temporary, portable construction supply container would be located at the Project Site at the beginning of construction and removed at the end of construction. Onsite parking would be provided for all construction workers.

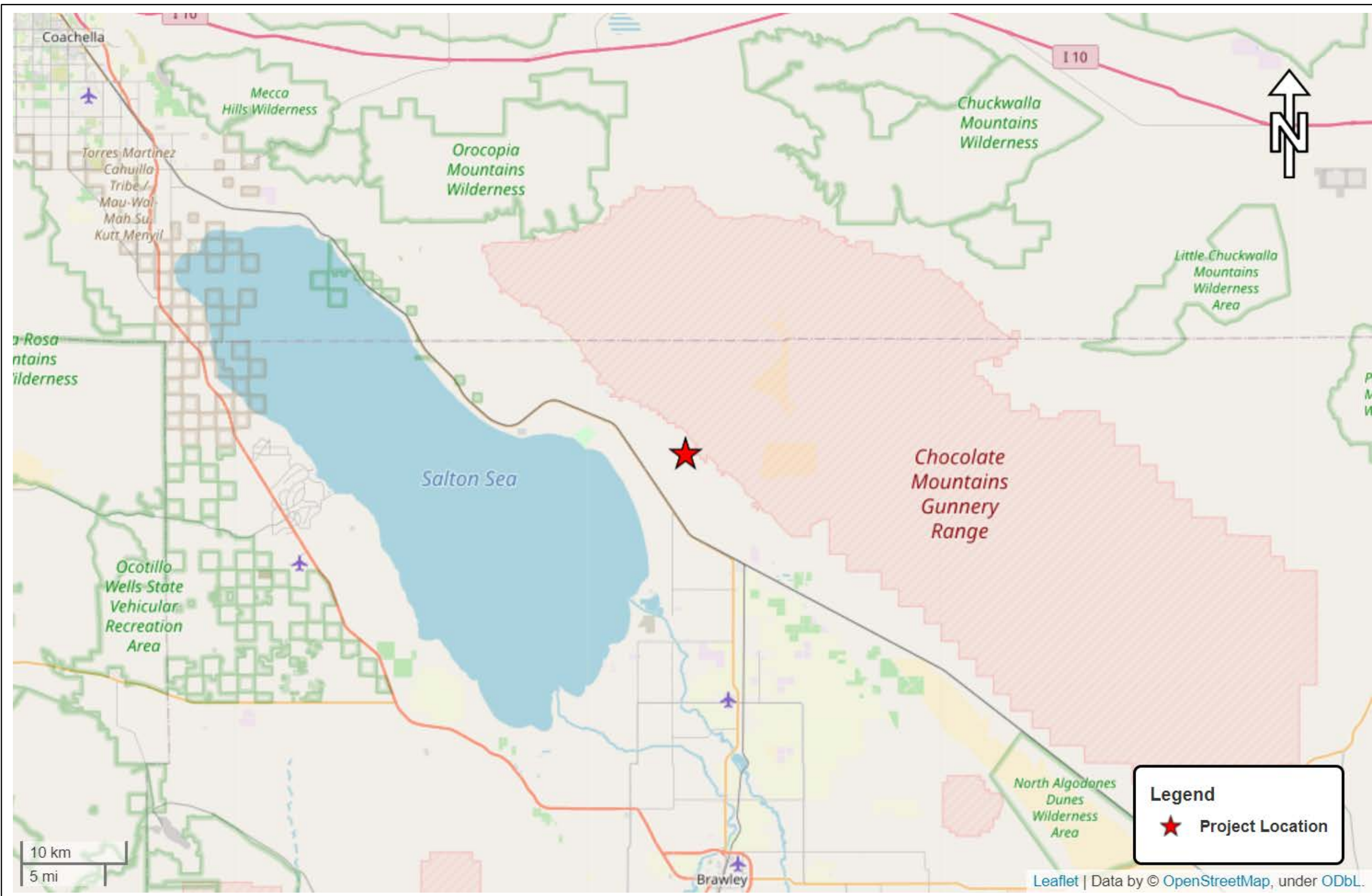

Legend
 ★ Project Location

Map Date: 5/12/2022
 Photo (or Base) Source: ECORP Consulting, Inc.



Figure 1. Project Regional Map

2022-102 North Star 1 Project

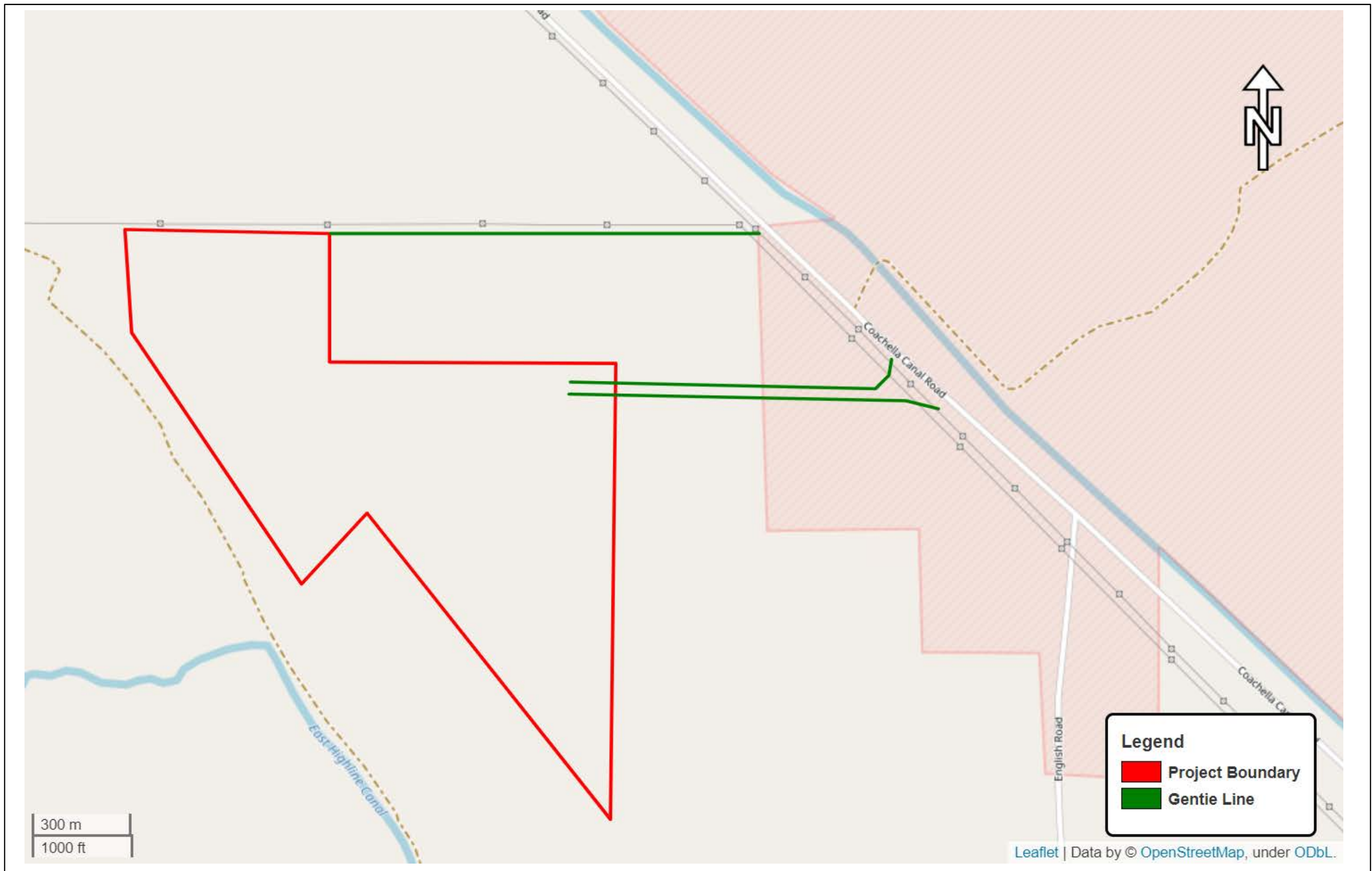

Map Date: 5/12/2022
 Photo (or Base) Source: ECORP Consulting, Inc.

Figure 2. Project Vicinity Map

2.0 ENERGY CONSUMPTION

2.1 Energy Types and Sources

California relies on a regional power system comprised of a diverse mix of natural gas, renewable, hydroelectric, and nuclear generation resources. Natural gas provides California with a majority of its electricity followed by renewables, large hydroelectric and nuclear (California Energy Commission [CEC] 2021a). Imperial Irrigation District (IID), the sixth largest electrical utility in California with 150,000 customers, serves all of Imperial County and parts of Riverside and San Diego counties, and provides electrical services to the Project Area. IID controls more than 1,100 megawatts of energy derived from a diverse resource portfolio that includes its own generation, and long- and short-term power purchases. Located in a region with abundant sunshine, enviable geothermal capacity, wind and other renewable potential, IID has met or exceeded all Renewable Portfolio Standard requirements to date, procuring renewable energy from diverse sources, including biomass, biowaste, geothermal, hydroelectric, solar and wind.

The Southern California Gas Company provides natural gas services to Imperial County. As the nation's largest natural gas distribution utility, the Southern California Gas Company delivers natural gas energy to 21.6 million consumers through 5.9 million meters in more than 500 communities. The Southern California Gas Company's service territory encompasses approximately 20,000 square miles throughout Central and Southern California, from Visalia to the Mexican border.

Imperial County, which encompasses the Project Site, contains 54 power plants generating electricity, of which 23 are solar-powered, 18 are geothermal, eight are hydro-powered, three are natural gas-fired, one is biomass-fired, and one is wind-powered (CEC 2021b).

2.1.1 Energy Consumption

Electricity use is measured in kilowatt-hours (kWh), and natural gas use is measured in therms. Vehicle fuel use is typically measured in gallons (e.g., of gasoline or diesel fuel), although energy use for electric vehicles is measured in kWh.

The electricity consumption associated with all nonresidential uses (such as the Proposed Project) in Imperial County from 2016 to 2020 is shown in Table 1. As indicated, the demand has decreased since 2016.

Year	Electricity Consumption (kilowatt hours)
2020	834,483,019
2019	839,095,659
2018	831,318,925
2017	817,450,656

Table 1. Electricity Consumption in Imperial County 2016 – 2020

Year	Electricity Consumption (kilowatt hours)
2016	895,952,526

Source: CEC 2021c

The natural gas consumption associated with all nonresidential uses in Imperial County from 2016 to 2020 is shown in Table 2. As indicated, the demand has increased since 2016.

Table 2. Natural Gas Consumption in Imperial County 2016-2020

Year	Natural Gas Consumption (therms)
2020	33,813,768
2019	34,736,596
2018	31,159,562
2017	33,090,927
2016	28,708,371

Source: CEC 2020c

Automotive fuel consumption in Imperial County from 2016 to 2021 is shown in Table 3. Fuel consumption has remained relatively constant between 2016 and 2021.

Table 3. Automotive Fuel Consumption in Imperial County 2016-2021

Year	Total On-Road Fuel Consumption
2021	216,105,185
2020	194,711,440
2019	217,988,585
2018	218,114,145
2017	220,106,315
2016	215,751,500

Source: California Air Resources Board (CARB) 2021

2.2 Regulatory Framework

2.2.1 State

2.2.1.1 Executive Order B-55-18

In September 2018 Governor Jerry Brown Signed Executive Order (EO) B-55-18, which establishing a new statewide goal “to achieve carbon neutrality as soon as possible, and no later than 2045, and achieve and maintain net negative emissions thereafter.” Carbon neutrality refers to achieving a net zero carbon dioxide emissions. This can be achieved by reducing or eliminating carbon emissions, balancing carbon emissions with carbon removal, or a combination of the two. This goal is in addition to existing statewide targets for GHG emission reduction. EO B-55-18 requires the California Air Resource Board (CARB) to “work with relevant state agencies to ensure future Scoping Plans identify and recommend measures to achieve the carbon neutrality goal.

2.2.1.2 Senate Bill 1368

On September 29, 2006, Governor Arnold Schwarzenegger signed into law Senate Bill (SB) 1368 (Perata, Chapter 598, Statutes of 2006). The law limits long-term investments in baseload generation by the state's utilities to those power plants that meet an emissions performance standard jointly established by the CEC and the California Public Utilities Commission (CPUC).

The CEC has designed regulations that:

- Establish a standard for baseload generation owned by, or under long-term contract to, publicly owned utilities, of 1,100 pounds carbon dioxide per megawatt hour (MWh). This would encourage the development of power plants that meet California's growing energy needs while minimizing their emissions of greenhouse gas.
- Require posting of notices of public deliberations by publicly owned utilities on long-term investments on the CEC website. This would facilitate public awareness of utility efforts to meet customer needs for energy over the long term while meeting the State's standards for environmental impact.
- Establish a public process for determining the compliance of proposed investments with the emissions performance standard (Perata, Chapter 598, Statutes of 2006).

2.2.2 Renewable Energy Sources (Renewable Portfolio Standards)

Established in 2002 under SB 1078, and accelerated by SB 107 (2006) and SB 2 (2011), California's Renewables Portfolio Standard (RPS) obligates investor-owned utilities, energy service providers, and community choice aggregators to procure 33 percent of their electricity from renewable energy sources by 2020. Eligible renewable resources are defined in the 2013 RPS to include biodiesel; biomass; hydroelectric and small hydro (30 megawatts or less); Los Angeles Aqueduct hydro power plants; digester gas; fuel cells; geothermal; landfill gas; municipal solid waste; ocean thermal, ocean wave, and tidal current technologies; renewable derived biogas; multi-fuel facilities using renewable fuels; solar photovoltaic;

solar thermal electric; wind; and other renewables that may be defined later. Governor Jerry Brown signed SB 350 on October 7, 2015, which expands the RPS by establishing a goal of 60 percent of the total electricity sold to retail customers in California per year by December 31, 2030. In addition, SB 350 includes the goal to double the energy efficiency savings in electricity and natural gas final end uses (such as heating, cooling, lighting, or class of energy uses upon which an energy efficiency program is focused) of retail customers through energy conservation and efficiency. The bill also requires the CPUC, in consultation with the CEC, establish efficiency targets for electrical and gas corporations consistent with this goal. SB 350 also provides for the transformation of the California Independent System Operator (CAISO) into a regional organization to promote the development of regional electricity transmission markets in the western states and to improve the access of consumers served by the CAISO to those markets, pursuant to a specified process. In 2018, SB 100 was signed by Governor Brown, codifying a goal of 60 percent renewable procurement by 2030 and 100 percent by 2045 Renewables Portfolio Standard.

2.3 Energy Consumption Impact Assessment

2.3.1 Thresholds of Significance

The impact analysis provided below is based on the following CEQA Guidelines Appendix G thresholds of significance. The Project would result in a significant impact to energy if it would do any of the following:

- 1) Result in potentially significant environmental impact due to wasteful, inefficient, or unnecessary consumption of energy resources, during project construction or operation.
- 2) Conflict with or obstruct a state or local plan for renewable energy or energy efficiency.

The impact analysis focuses on the four sources of energy that are relevant to the Proposed Project: electricity, natural gas, the equipment fuel necessary for Project construction, and the automotive fuel necessary for Project operations. Addressing energy impacts requires an agency to make a determination as to what constitutes a significant impact. There are no established thresholds of significance, statewide or locally, for what constitutes a wasteful, inefficient, and unnecessary consumption of energy for a proposed land use. For the purposes of this analysis, the amount of electricity and natural gas estimated to be consumed by the Project are quantified and compared to that consumed by all land uses in Imperial County. Similarly, the amount of fuel necessary for Project construction and operations is calculated and compared to that consumed in Imperial County.

2.3.2 Methodology

Levels of construction and operational related energy consumption estimated to be consumed by the Project include the number of kWh of electricity, therms of natural gas and gallons of gasoline. The amount of total construction-related fuel used was estimated using ratios provided in the Climate Registry's General Reporting Protocol for the Voluntary Reporting Program, Version 2.1. Electricity and natural gas consumption estimates were calculated using the California Emissions Estimator Model (CalEEMod), version 2020.4.0 (Air Quality and Greenhouse Gas Emissions Assessment: North Star 1 Project [ECORP 2022]). CalEEMod is a statewide land use computer model designed to quantify resources associated with both construction and operations from a variety of land use projects. Operational

automotive fuel consumption has been calculated with EMFAC 2021. EMFAC 2021 is a mathematical model that was developed to calculate emission rates and rates of gasoline consumption from motor vehicles that operate on highways, freeways, and local roads in California.

2.3.3 Impact Analysis

2.3.3.1 Project Energy Consumption

The Project proposes the construction of a nominal 50-MW alternating current solar PV energy generation system with an integrated 75 MW battery storage system spanning approximately 287 acres of land. Operations of the Proposed Project would not result in the consumption of electricity or natural gas and thus, would not contribute to the County wide usage. Instead, the Project would directly support the RPS goal of increasing the percentage of electricity procured from renewable sources.

Therefore, the consumption of electricity and natural gas is not a factor in this analysis. The two sources of energy associated with the Project includes the equipment fuel necessary for construction and the automotive fuel necessary for ongoing maintenance activities. For the purpose of this analysis, Project increases in construction and automotive fuel consumption are compared with the countywide fuel consumption in 2020, the most recent full year of data. This analysis conservatively assumes that all of the automobile trips projected to arrive at the Project during operations would be new to Imperial County.

Energy consumption associated with the Proposed Project is summarized in Table 4.

Table 4. Proposed Project Energy and Fuel Consumption		
Energy Type	Annual Energy Consumption	Percentage Increase Countywide
Facility Electrical and Natural Gas Consumption		
Electricity Consumption ¹	0 kilowatt-hours	0.00000 percent
Natural Gas ¹	0 therms	0.00000 percent
Automotive Fuel Consumption		
Project Construction 2023 ²	104,828 gallons	0.048 percent
Project Construction 2024 ²	34,581 gallons	0.016 percent
Project Operations ³	3,828 gallons	0.001 percent

Source: ¹CalEEMod; ²Climate Registry 2016; ³EMFAC2021 (CARB 2020)

Notes: The Project increases in electricity and natural gas consumption are compared with all uses in Imperial County in 2019, the latest data available. The Project increases in automotive fuel consumption are compared with the countywide fuel consumption in 2021, the most recent full year of data.

Fuel necessary for Project construction would be required for the operation and maintenance of construction equipment and the transportation of materials to the Project Site. The fuel expenditure necessary to construct the solar facility and infrastructure would be temporary, lasting only as long as Project construction. As indicated in Table 4, the Project’s gasoline fuel consumption during the one-time

construction period is estimated to be 104,828 gallons during 2023 construction and 34,581 gallons during 2024 construction. This would increase the annual countywide gasoline fuel use associated with offroad equipment in the County by 0.048 percent and 0.016 percent, respectively. As such, Project construction would have a nominal effect on local and regional energy supplies. No unusual Project characteristics would necessitate the use of construction equipment that would be less energy efficient than at comparable construction sites in the region or the state. Construction contractors would purchase their own gasoline and diesel fuel from local suppliers and would judiciously use fuel supplies to minimize costs due to waste and subsequently maximize profits. Additionally, construction equipment fleet turnover and increasingly stringent state and federal regulations on engine efficiency combined with state regulations limiting engine idling times and requiring recycling of construction debris, would further reduce the amount of transportation fuel demand during Project construction. For these reasons, it is expected that construction fuel consumption associated with the Project would not be any more inefficient, wasteful, or unnecessary than other similar development projects of this nature.

Once construction is completed the Project would be remotely controlled. No employees would be based at the Project site. The only operational emissions associated with the Project would be associated with motor vehicle use for routine maintenance work, water import, and site security as well as panel upkeep and cleaning. Four heavy-duty truck vehicle trips per day for routine maintenance work, site security, and trucking in water was assumed. This is a conservative estimate as most days would require no operational related vehicle trips. As indicated in Table 4, this would estimate to a consumption of approximately 3,470 gallons of automotive fuel per year, which would increase the annual countywide automotive fuel consumption by 0.001 percent. Fuel consumption associated with both the construction equipment needed to construct the Project and the vehicle trips generated by the Project during ongoing maintenance activities would not be considered inefficient, wasteful, or unnecessary in comparison to other similar developments in the region.

State and Local Plans for Renewable Energy/Energy Efficiency

The purpose of the Proposed Project is the construction of a renewable energy and storage facility in Imperial County. Once in operation, it will decrease the need for energy from fossil fuel-based power plants in the state. The result would be a net increase in electricity resources available to the regional grid, generated from a renewable source. Therefore, the Project would directly support the RPS goal of increasing the percentage of electricity procured from renewable sources. Additionally, the Project would also be consistent with the County's General Plan Conservation and Open Space Element, Objective 9.2, which encourages renewable energy developments. Therefore, the Project would directly support state and local plans for renewable energy development.

3.0 REFERENCES

California Air Resources Board (CARB). 2020. EMFAC2021 Web Database Emissions Inventory.
<https://www.arb.ca.gov/emfac/2021/>

California Energy Commission (CEC). 2021a. 2020 Total System Electric Generations in Gigawatt Hours.
Available online at: <https://www.energy.ca.gov/data-reports/energy-almanac/california-electricity-data/2020-total-system-electric-generation>

_____. 2021b. Website: Annual Generation – County.
https://ww2.energy.ca.gov/almanac/electricity_data/web_qfer/Annual_Generation-County cms.php

_____. 2021c. California Energy Consumption Database. <http://www.ecdms.energy.ca.gov/Default.aspx>.

Climate Registry. 2016. General Reporting Protocol for the Voluntary Reporting Program version 2.1.
January 2016. <http://www.theclimateregistry.org/wp-content/uploads/2014/11/General-Reporting-Protocol-Version-2.1.pdf>

ECORP Consulting, Inc. 2023. *Air Quality and Greenhouse Gas Emissions Assessment for the North Star 1 Project*. February 28.

APPENDIX A

Energy Consumption Modeling Output

**Proposed Project
Total Construction-Related and Operational
Gasoline Usage**

Construction

Table 1. Construction Year One			
Action	Carbon Dioxide Equivalents (CO₂e) in Metric Tons¹	Conversion of Metric Tons to Kilograms²	Construction Equipment Emission Factor²
Project Construction	1064	1,064,000	10.15
Total Gallons Consumed During Construction Year One:			104,828

Table 2. Construction Year Two			
Action	Carbon Dioxide Equivalents (CO₂e) in Metric Tons¹	Conversion of Metric Tons to Kilograms²	Construction Equipment Emission Factor²
Project Construction	351	351,000	10.15
Total Gallons Consumed During Construction Year Two:			34,581

Sources:

¹ECORP Consulting. 2022. Air Quality and Greenhouse Gas Emissions Assessment: Northstar #1 Project

²Climate Registry. 2016. *General Reporting Protocol for the Voluntary Reporting Program version 2.1*. January 2016.
<http://www.theclimateregistry.org/wp-content/uploads/2014/11/General-Reporting-Protocol-Version-2.1.pdf>

**Proposed Project
Total Construction-Related and Operational
Gasoline Usage**

Operations

Table 5. Average Miles per Gallon in Imperial County in 2021³								
Area	Sub-Area	Cal. Year	Season	Veh_tech	EMFAC 2021 Category	Total Onroad Vehicle Gallons Consumed in Imperial County in 2021	Total Onroad Vehicle Miles Traveled in Imperial County in 2021	Total Passenger Vehicle Miles per Gallon in Imperial County in 2021
Sub-Areas	Imperial County	2021	Annual	All Vehicles	All Vehicles	216,105,185	3,873,811,795	17.93

Sources:
³California Air Resource Board. 2021. EMFAC2021 Mobile Emissions Model.

Table 6. Total Gallons During Project Operations				
Project Onroad Vehicle Daily Trips ³	Estimated Miles per Trip ⁴	Project Onroad Vehicle Daily Miles Traveled	Project Onroad Vehicle Daily Fuel Consumption	Project Onroad Vehicle Annual Fuel Consumption
4	47	188.00	10.49	3,828

NORTHSTAR 1

CONFIDENTIAL DOCUMENTS
 THE INFORMATION EMBODIED ON THIS DRAWING IS STRICTLY CONFIDENTIAL AND IS SUPPLIED WITH THE UNDERSTANDING THAT IT WILL BE HELD CONFIDENTIAL AND NOT DISCLOSED TO THIRD PARTIES WITHOUT THE PRIOR WRITTEN CONSENT OF ZGLOBAL, INC.

REV.	BY	DESCRIPTION	DATE	APP'D BY
0	RO	SUBMITTAL #1	2/24/22	HP
1	RO	UPDATED GENITE	08/05/22	HP

Scale to Contain 24"x36" Plot
 1 inch
 PLOT: 8/5/2022 4:06 PM

ZGLOBAL
 Power Engineering & Energy Solutions
 604 SUTTER ST, STE 250
 FOLSOM, CA 95630
 Phone : 916.985.9461
 Fax: 916.985.9467

THESE DRAWINGS AND SPECIFICATIONS HAVE BEEN PREPARED BY ZGLOBAL, INC. FOR THEIR EXCLUSIVE USE IN CONNECTION WITH SEC. 6137.3 OF THE CALIFORNIA PUBLIC UTILITIES ACT AND THE STATE OF CALIFORNIA.

SHEET TITLE:
ACCESS ROAD

DRAWN BY:	RO	DRAWING NO.	
CHECKED:	HP		
SCALE:			
JOB NO.:			
DATE:		REV No.	1

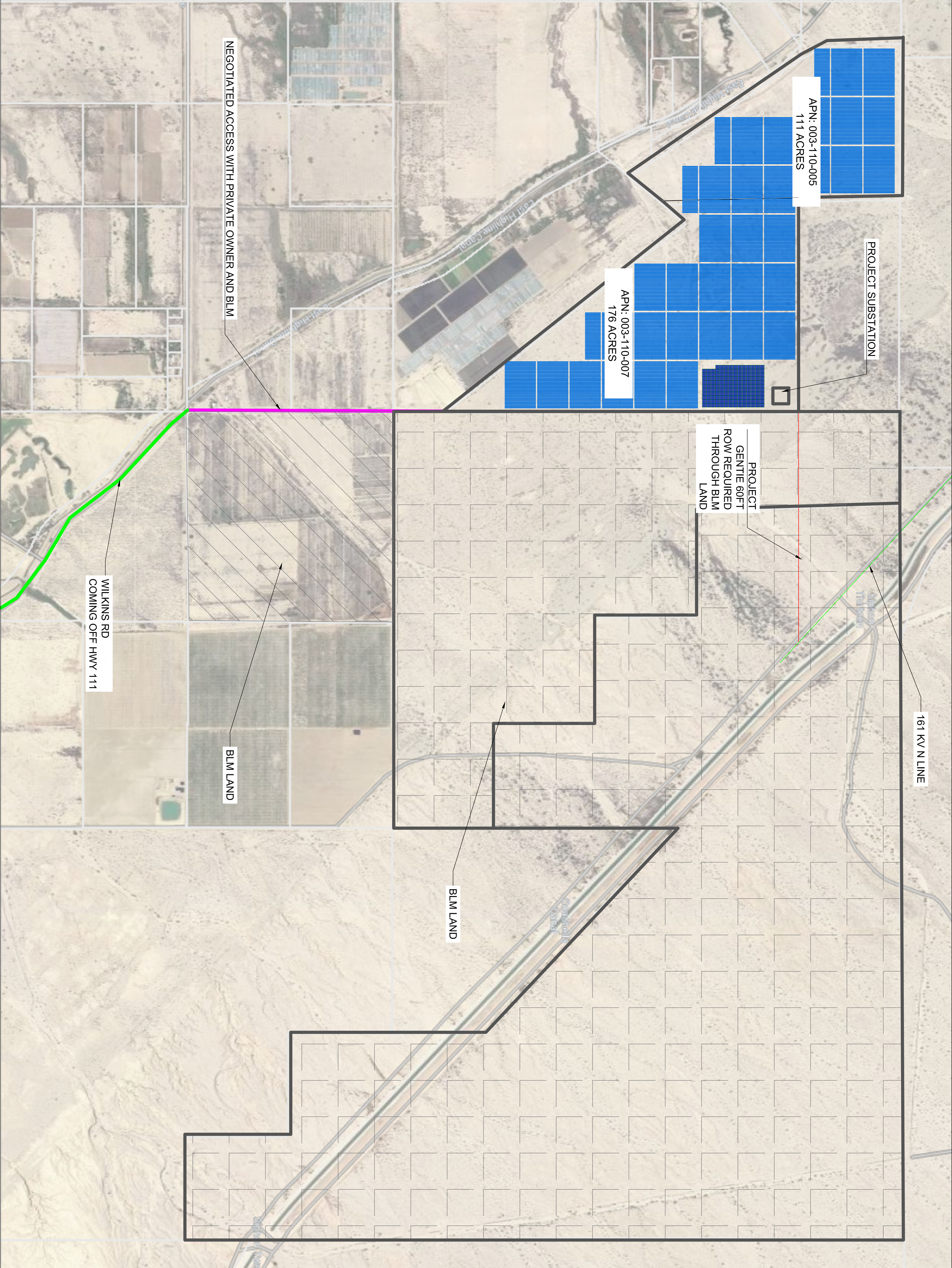

NORTHSTAR 1

CONFIDENTIAL DOCUMENTS
 THE INFORMATION EMBODIED ON THIS DRAWING IS STRICTLY CONFIDENTIAL AND IS SUPPLIED WITH THE UNDERSTANDING THAT IT WILL BE HELD CONFIDENTIAL AND NOT DISCLOSED TO THIRD PARTIES WITHOUT THE PRIOR WRITTEN CONSENT OF ZGLOBAL, INC.

REV.	BY	DESCRIPTION	DATE	APP'D BY
0	RO	SUBMITAL #1	2/24/22	HP
1	RO	UPDATED GENITE	08/05/22	HP

Scale to Conform 24"x36" Plot
 1 inch
 PLOT: 8/5/2022 4:08 PM



604 SUTTER ST., STE 250
 FOLSOM, CA 95630
 Phone : 916.985.9461
 Fax: 916.985.9467

THESE DRAWINGS AND SPECIFICATIONS HAVE BEEN PREPARED BY ZGLOBAL, INC. FOR THEIR EXCLUSIVE USE IN ACCORDANCE WITH SEC. 6173.3 OF THE CALIFORNIA PROFESSIONAL ENGINEERS ACT OF THE STATE OF CALIFORNIA.

SITE PLAN

SHEET TITLE: NORTHSTAR - 1

DRAWN BY:	RO	DRAWING NO.:	
CHECKED:	HP		
SCALE:			
JOB NO.:			
DATE:		REV No.:	1

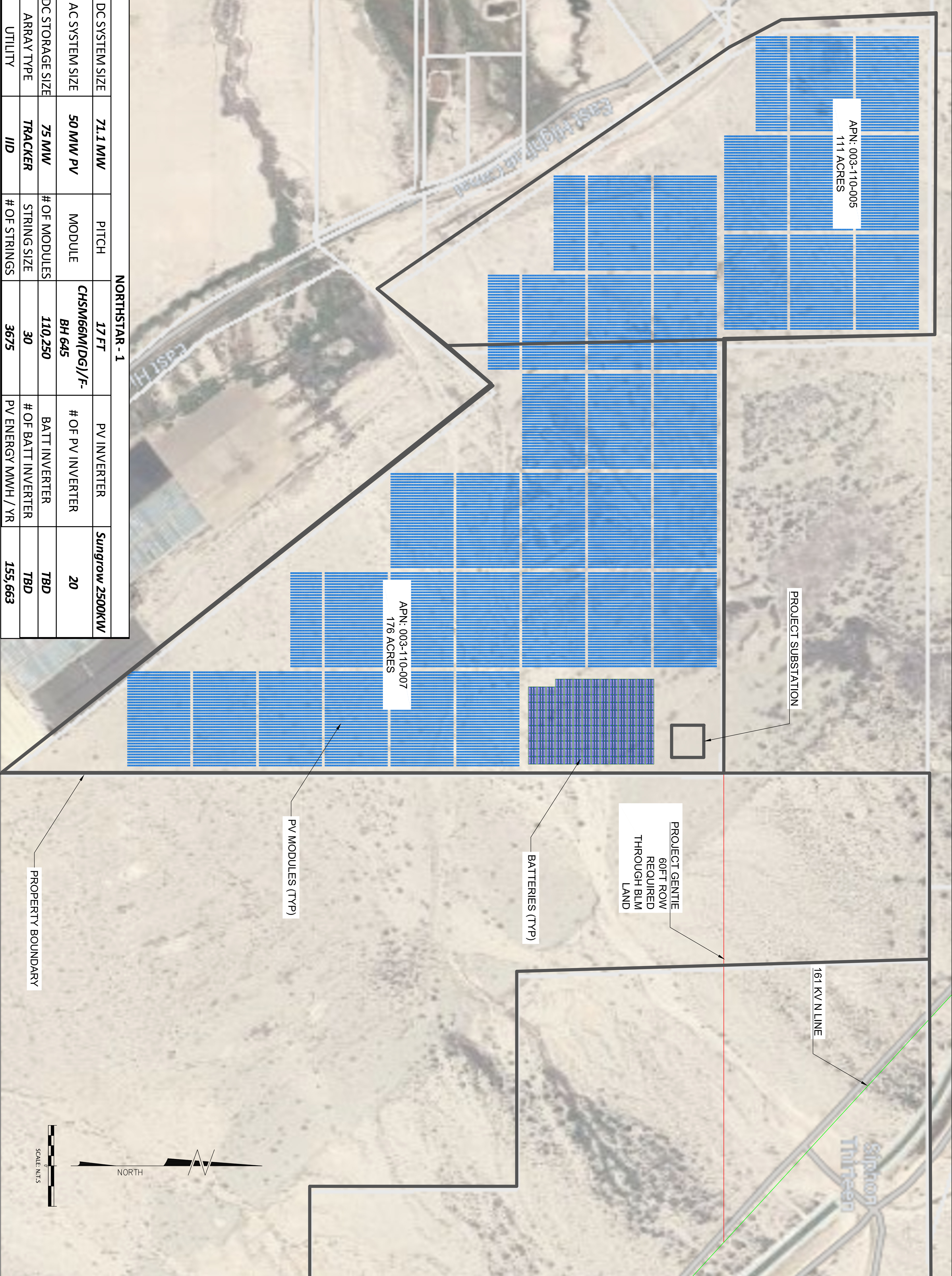

NORTHSTAR - 1			
DC SYSTEM SIZE	71.1 MW	PITCH	17 FT
AC SYSTEM SIZE	50 MW PV	MODULE	CHSM66M(DG)/F- BH 645
DC STORAGE SIZE	75 MWh	# OF MODULES	110,250
ARRAY TYPE	TRACKER	STRING SIZE	30
UTILITY	IID	# OF STRINGS	3675
		PV INVERTER	Sungrow 2500KW
		# OF PV INVERTER	20
		BATT INVERTER	TBD
		# OF BATT INVERTER	TBD
		PV ENERGY MWh / YR	155,663



DRAFT AQUATIC RESOURCE DELINEATION REPORT

**North Star 1 ECORP Project Number: 2022-102
Imperial County, CA
January 2023**

**Prepared by:
Hernandez Environmental Services
17037 Lakeshore Drive
Lake Elsinore, CA 92530**

**Prepared for:
Don Mitchell
ECORP
215 North 5th Street
Redlands, CA 92374**

TABLE OF CONTENTS

1.0	Introduction.....	iv
2.0	Location	iv
3.0	Methods.....	iv
3.1	Literature Review.....	iv
3.2	Field Survey	iv
4.0	Existing Conditions.....	v
4.1	Environmental Setting.....	v
4.2	Existing Hydrological Features	v
4.3	Soils.....	vi
4.5	Hydrology.....	viii
4.6	Existing Wetlands	ix
4.7	California Department of Fish and Wildlife	ix
4.8	Waters of the United States	ix
4.9	Regional Water Quality Control Board Jurisdiction	ix
5.0	Impacts to Jurisdictional Areas	ix
5.1	California Department of Fish and Wildlife	ix
5.2	Waters of the United States	ix
5.3	Waters of the State	x
6.0	Recommendations.....	x
7.0	Certification	xii
8.0	References.....	xiii

FIGURES

Figure 1 – Location Map

Figure 2 – Vicinity Map

Figure 3 – Project Plans

Figure 4 – CDFW Jurisdiction Map

Figure 5 – Waters of the United States Map

Figure 6 – Waters of the State Map

Figure 7 – CDFW Habitats

APPENDICES

Appendix A – Site Photographs

Appendix B – Soil Map

1.0 Introduction

This report summarizes the results of the aquatic resources delineation completed by Hernandez Environmental Services (HES) on the approximately 285.74-acre project site. The purpose of this report is to identify and describe aquatic resources and, to identify known possible sensitive plant, fish, and wildlife species in the survey area. This report facilitates efforts to document aquatic resource boundary determinations for review by regulatory authorities.

Report Prepared for:

Company:

Address:

Contact:

Phone:

Email:

2.0 Location

North Star 1 is located southwest of Coachella Canal within Imperial County, California (Figures 1 and 2). Specifically, the project site can be found in Section 1, Township 10 South, Range 13 East, including a portion of the generation tie line and in/out loop within Section 6, Range 14 East in the United States Geological Survey *Wister* 7.5-Minute Quadrangle. The center point latitude and longitude coordinates for the project site are 33°20'01.2022" North and 115°34'11.2960" West (Figures 1 and 2).

3.0 Methods

3.1 Literature Review

Prior to the site visit, a literature review was conducted to aid in determining the potential for permanent, intermittent, or ephemeral drainages, wetlands, and riparian vegetation. Project background documents, topographic maps, satellite imaging, soils maps, and land use maps were examined to establish an accurate project site location, project description, potential for onsite drainages and wetlands, records of on-site vegetation, watershed, soils, and surrounding land uses.

3.2 Field Survey

On October 25th, 2022, HES conducted a field survey of the west side of the 285.74-acre study area. The purpose of this field survey was to document the existing habitat conditions, obtain plant and animal species information, view the surrounding land uses, and assess the potential for state and federal waters. Representative site photographs were taken and are included in Appendix A.

During the field survey, six transects were walked from the south project boundary to the north project boundary at approximately 250 feet apart. The purpose of the transects was to evaluate the presence or absence of fluvial activity, boundaries of geomorphic units, changes in plant species composition between different geomorphic units, photographing points of transition, and mapping the watercourse and watercourse boundaries. The guidelines followed are those established in the 2014 Mapping Episodic Stream Activity (MESA) Field Guide. Areas measured were recorded using a handheld Global Positioning System (GPS) for accurate location reference, and site photographs were also taken.

Jurisdictional drainages were identified by looking for features such as a bed, bank, or channel. Where riparian vegetation was present, the drip line of the outer edge of the vegetation was used as the measuring criteria. Furthermore, the presence of an ordinary high-water mark (OHWM) was recorded. The OHWM is defined as: “on non-tidal rivers, the line on the shore established by the fluctuations of water and indicated by the physical characteristics such as a clear, natural line impressed on the bank; shelving; changes in the character of soil; destruction of terrestrial vegetation; the presence of litter and debris; or other appropriate means that consider the characteristics of the surrounding area.” Where the presence of an OHWM was evident, a measurement was taken for the width of the OHWM, and the measurement was recorded. Areas measured were also recorded using hand-held GPS for accurate location reference.

Where changes in plant community composition were apparent, the area was examined for the possibility of wetlands. Whether or not adjacent to “waters of the U.S.,” the potential wetland area was evaluated for the presence of the three wetland indicators: hydrology, hydric soils and hydrophytic vegetation. The guidelines followed are those established in the 1987 Army Corps of Engineers Manual.

4.0 Existing Conditions

4.1 Environmental Setting

The 285.74-acre study area reflects the arid conditions, limited rainfall, and generally poor soils of the Sonoran Desert. The proposed project site exhibits a range of vegetation types including iodine bush (*Allenrolfea occidentalis*), creosote bush (*Larrea tridentata*), and ironwood (*Olneya tesota*) southwest of the Chocolate Mountains. Plant species composition varies depending upon the location. The elevation of the action area ranged from -69 to 79 feet above mean sea level (AMSL). The peak blooming season for desert vegetation typically occurs during the months of February, March, and April, and in years of abundant annual rainfall.

4.2 Existing Hydrological Features

The ephemeral streams that run through the project site originate from the Chocolate Mountains located approximately 5.3 miles to the northeast. The study area is an extension of watershed

extending from the Southern Mojave into the Salton Sea and contains braided channels and vegetation associated with the larger channel complex.

4.3 Soils

Three soil classes are identified to occur on the project site by the USDA Web Soil Survey (Appendix B, *Soils Map*). Soils at the project site are classified as follows:

- Niland gravelly sand (124),
- Niland gravelly sand, wet (125); and
- Niland-Imperial complex, wet (128)

The soils above are well drained and do not allow for water to pond for long periods of time.

4.4 Vegetation

The study area supports streams with nine different habitat types: creosote bush scrub, iodine bush scrub, disturbed iodine bush scrub, blue palo verde/ironwood woodland, bush seepweed scrub, disturbed bush seepweed scrub, disturbed tamarisk thickets, four-wing saltbush scrub, disturbed four-wing saltbush scrub, and a disturbed manmade earthen canal. These habitat types are described in more detail below.

Creosote Bush Scrub

The project area contains approximately 30.25 acres of upland vegetated streams with creosote bush scrub habitat. Creosote bush (*Larrea tridentata*) does not have an indicator rating on the national wetland plant list (NWPL). This habitat type is characterized as a shrub canopy with creosote bush as the dominant species and numerous other shrub species below three meters. This habitat type is typically found on alluvial fans, bajadas, upland slopes, and washes. Other species observed are white bursage (*Ambrosia dumosa*), cheese bush (*Ambrosia salsola*), and honeysweet (*Tidestromia suffruticosa*).

Iodine Bush Scrub

The project area contains approximately 6.43 acres of ephemeral streams with iodine bush scrub habitat. Iodine bush (*Allenrolfea occidentalis*) has an indicator status of facultative wet (FACW) on the NWPL. FACW plants usually occur in wetlands but occasionally are found in non-wetlands. This habitat type is characterized as a shrub canopy with iodine bush as the dominant species. This habitat type is typically found on playas perched above drainages, seep, and dry lakebed margins. Other species observed are four-wing saltbush (*Atriplex canescens*), tamarisk (*Tamarix* spp.), and bush seepweed (*Suaeda moquinii*).

Disturbed Iodine Bush Scrub

The project area contains approximately 0.07 acre of upland vegetated ephemeral streams with disturbed iodine bush scrub habitat. This habitat type is characterized by iodine bush as the dominant species in the shrub canopy with an absent herbaceous layer. On the Project Site, this vegetation cover is characterized as sparse with a high percentage of anthropogenic disturbances such as grading, tire tracks, and trash.

Blue Palo Verde/Ironwood Woodland

The project area contains approximately 5.23 acres of ephemeral streams with blue palo verde/ironwood riparian woodland habitat. Blue palo verde (*Parkinsonia florida*) and ironwood (*Olneya tesota*) do not have indicator ratings on the NWPL. This habitat type is characterized as a tree canopy with blue palo verde and ironwood as the co-dominant species and numerous other shrub species below three meters. This habitat type is typically found on desert arroyo margins, bottomlands, middle and upper bajadas, alluvial fans, washes, and lower slopes. Other species observed were sweetbush (*Bebbia juncea*), and brittlebush (*Encelia farinosa*).

Bush Seepweed Scrub

The project area contains approximately 3.81 acres ephemeral streams with bush seepweed scrub habitat. Bush seepweed (*Suaeda nigra*) has an indicator status of obligate (OBL). OBL species occur almost always under natural conditions in wetlands. This habitat type is characterized by bush seepweed, which can be co-dominant with four-wing saltbush and/or alkali goldenbush (*Isocoma acradenia*) as the dominant or co-dominant species. This habitat type is typically found on flat to gently sloping valley bottoms, bajadas, and toe slopes adjacent to alluvial fans. Other species observed are four-wing saltbush, arrow weed, and tamarisk.

Disturbed Bush Seepweed Scrub

The project area contains approximately 2.48 acres of upland vegetated ephemeral streams with disturbed bush seepweed scrub habitat. This habitat type is characterized by iodine bush as the dominant species in the shrub canopy with an absent to sparse herbaceous layer. On the Project Site, this vegetation cover is characterized as sparser with a high percentage of anthropogenic disturbances such as grading, tire tracks, and trash.

Disturbed Tamarisk thickets

The project area contains approximately 3.06 acres of upland vegetated ephemeral streams with disturbed tamarisk thickets habitat. This habitat type is characterized by salt cedar (*Tamarix*

ramosissima) or other species of tamarisk (*Tamarix* spp.) as the dominant species with an absent herbaceous layer. On the Project Site, this vegetation cover is characterized as sparse with a high percentage of anthropogenic disturbances such as grading, tire tracks, and trash.

Four-wing Saltbush Scrub

The project area contains approximately 12.68 acres four-wing saltbush scrub habitat. This habitat type is characterized as a shrub canopy with four-wing saltbush (*Atriplex canescens*) as the dominant species and can be co-dominant with white bursage, cheesebush, and/or cattle spinach (*Atriplex polycarpa*). Four-wing saltbush does not have an indicator rating on the NWPL. This habitat type is typically found on playas, old beach and shores, lake deposits, alluvial fans, and rolling hills. Other species observed are creosote bush, cheesebush, white bursage, goldenbush, and tamarisk.

Disturbed Fourwing Saltbush Scrub

The project area contains approximately 2.09 acres of upland vegetated ephemeral streams with disturbed four-wing saltbush scrub habitat. This habitat type is characterized by four-wing saltbush with an absent to sparse herbaceous layer. On the Project Site, this vegetation cover is characterized as sparse with a high percentage of anthropogenic disturbances such as grading, tire tracks, and trash.

Disturbed Manmade Earthen Canal

The North Star 1 project site contains approximately 0.17 acre of a disturbed manmade earthen canal. The canal collects flows from the drainages that cross the northern portion of the site and runs south to north along a portion of the western border of the site. The banks of the canal appear to be maintained and are non-vegetated. Iodine bush shrubs line the low flow channel within the canal.

4.5 Hydrology

The project area is located within the Colorado River Basin Plan and the Imperial Valley hydrologic unit. The Imperial Valley has not been included as part of the Colorado River Aquifer System based on information published by the USGS. The project site contains ephemeral streams that flow from east to west and are unnamed tributaries that form a braided channel to the Salton Sea. The Salton Sea is a navigable water as defined by the USACOE.

4.6 Existing Wetlands

The study area does not contain federally defined wetlands (the presence of the three wetland indicators which are hydric soils, hydrophytic vegetation, and hydrology). Although there are areas that have indicators of ponding water (cracked soils), no hydrophytic vegetation is present within these areas onsite. The cracked soils onsite were found within disturbed saltbush scrub, which does not have indicator rating on the national wetland plant list.

4.7 California Department of Fish and Wildlife

The study area contains approximately 66.27 acres of upland-vegetated ephemeral streams. These drainage features are regulated by Section 1602 of the California Fish and Game Code (Figure 4).

4.8 Waters of the United States

The study area contains approximately 59.06 acres of upland-vegetated ephemeral streams. These drainage features are regulated by the United States Army Corps of Engineers pursuant to provisions of Section 404 of the Clean Water Act (Figure 5).

4.9 Regional Water Quality Control Board Jurisdiction

The study area contains approximately 59.34 acres of ephemeral streams that are considered waters of the State subject to the State of California Porter-Cologne Act and regulated by the Colorado River Basin Regional Water Quality Control Board (Figure 6). A beneficial use is one of the various ways that water can be used for the benefit of people and/or wildlife. Beneficial uses for the onsite ephemeral drainages have been identified by the East Colorado River Basin Plan as Groundwater Recharge (GWR), Non-Contact Water Recreation (REC2), Wildlife Habitat (WILD), and on a case-by-case basis as Warm Freshwater Habitat (WARM).

5.0 Impacts to Jurisdictional Areas

5.1 California Department of Fish and Wildlife

A total of 66.27 acres of ephemeral streams that fall under CDFW jurisdiction is expected to be impacted by the proposed project. Impacts to CDFW jurisdictional waters will require the CDFW be notified under the 1602 Streambed Alteration Agreement Notification. CDFW will then decide to issue a draft 1602 Lake and Streambed Alteration Agreement with mitigation measures to protect fish and wildlife riparian resources.

5.2 Waters of the United States

A total of 59.06 acres of ephemeral streams that are classified as waters of the United States is expected to be impacted by the proposed project. Impacts to Waters of the United States will

require an Individual 404-permit issued by the United States Army Corps of Engineers for projects with impacts greater than 0.5 acre. Individual permits require detailed analysis and compliance with the USACE formal review process. This process includes preparation of an alternatives analysis as required by EPA Section 404(b)(1) Guidelines and the National Environmental Policy Act (NEPA) and requires compliance with NEPA's environmental review process. This process provides opportunities for public notice and comment. The USACE must also comply with other federal regulations, including the federal Endangered Species Act, EPA Section 404(b)(1) Guidelines, NEPA, and Section 106 of the National Historic Preservation Act. BLM will review this project under NEPA. Permittees should contact the appropriate Corps district office to find if a preapplication meeting is required before submitting the IP application. Applying for an IP requires compliance with the USACE formal review process. The formal review process includes the preparation of alternatives analysis to determine the Least environmentally damaging practicable alternative (LEDPA) as required by EPA 404(b)(1) guidelines.

Below is a list of documents required to obtain an Individual Permit:

- Initial study, negative declaration, mitigated negative declaration, or environmental impact report in accordance with the California Environmental Quality Act (CEQA).
- Cultural Study
- Hydrology Study
- Storm Water Pollution Prevention Plan (SWPPP)
- Water Quality Management Plan (WQMP)

5.3 Waters of the State

A total of 59.34 acres of ephemeral streams that are considered waters of the State is expected to be impacted by the proposed project. These waters will be subject to the jurisdiction of the Colorado River Basin Regional Water Quality Control Board. The 59.34 acres of impacts to these waters will require notifying the RWQCB to determine if a Clean Water Act 401 Certification or a Porter-Cologne Waste Discharge Requirements will be issued to mitigate impacts to state beneficial uses of state and federal waters.

6.0 Recommendations

USACE, CDFW, and RWQCB jurisdictional waters are regulated by federal, state, and local governments under a no-net-loss policy, and all impacts are considered significant and should be avoided to the greatest extent possible. CDFW and RWQCB jurisdictional waters are regulated by state and local governments under a no-net-loss policy, and all impacts are considered significant

and should be avoided to the greatest extent possible. Impacts to jurisdictional waters require mitigation through habitat creation, restoration, or enhancement as determined by consultation with the regulatory agencies during the permitting process. Any impacts to CDFW jurisdiction would require a Section 1602 Streambed Alteration Agreement from CDFW. Any impacts to waters of the State would require a 401 State Water Quality Certification and WDR under Porter-Cologne from the RWQCB. Any unavoidable impacts to jurisdictional areas can also be mitigated for through the purchase of credits at an existing mitigation bank or in lieu fee program. The Colorado Basin Regional Water Quality Control Board will need to be notified to determine if the proposed project will require Waste Discharge Requirements to mitigate any impacts to the beneficial uses of state waters.

7.0 Certification

“CERTIFICATION: I hereby certify that the statements furnished above and in the attached exhibits present the data and information required for this jurisdictional delineation, and that the facts, statements, and information presented are true and correct to the best of my knowledge and belief.”



DATE 01/25/2023 SIGNED _____

Project Manager

Fieldwork Performed By:

Elizabeth Gonzalez

SENIOR BIOLOGIST

Sarah Vasquez

ASSOCIATE BIOLOGIST

8.0 References

CDFW (California Department of Fish and Wildlife). 2010. A Review of Stream Processes and Forms in Dryland Watersheds. Prepared by Kris Vyverberg, Conservation Engineering.

CDFW (California Department of Fish and Wildlife). 2013. Fish and Game Code of California.

California Regional Water Quality Control Board, Santa Ana Region. 2016. Water Quality Control Plan for the Santa Ana River Basin. Santa Ana, California.

California State Water Resources Control Board. 2019. Porter-Cologne Water Quality Control Act, Water Code Division 7 and Related Sections.

Department of the Army. 1986 (Nov 13). 33 CFR Parts 320 Through 330, Regulatory Programs of the Corps of Engineers; Final Rule. Federal Register 51(219):41206-41206.

Department of the Army. 2000 (Mar 9). 33 CFR Parts 320 Through 330, Regulatory Programs of the Corps of Engineers; Final Rule. Federal Register 65(47):12818-12899.

Department of the Army. 2002 (Jan 15). 33 CFR Parts 320 Through 330, Regulatory Programs of the Corps of Engineers; Final Rule. Federal Register 67(10):20020-2095.

Department of the Army, Corps of Engineers, Department of Defense; and Environmental Protection Agency (EPA). 2020. 33CFR Part 328, 40 CFR Parts 110, 112, 116, 117, 120, 122, 230, 232, 300, 302, and 401; The Navigable Waters Protection Rule: Definition of “Waters of the United States.” Federal Register 85(77): 22250-22342.

Hickman, J.C. 1993. The Jepson Manual: Higher Plants of California. University of California Press. Berkeley, California.

Holland, R.F. 1986 (updated 1996). Preliminary Descriptions of the Terrestrial Natural Communities of California. Non-game Heritage Program. California Department of Fish and Game. Sacramento, California.

Munz, P.A. 1974 A Flora of Southern California. University of California Press. Berkeley, California.

Reed, P.B. 1988. National List of Plant Species That Occur in Wetlands: California (Region 0). National wetlands Inventory, US Fish and Wildlife Biological Report 88 (26.9).

Sawyer, J.O. and T. Keeler-Wolf. 1995. A Manual of California Vegetation. California Native Plant Society. Sacramento, California.

USACE (United States Army Corps of Engineers). 1987. Corps of Engineers Wetlands Delineation Manual. Technical Report Y-87-1. U.S. Army Corps of Engineers Waterways Experiment Station. Vicksburg, Mississippi.

USACE (United States Army Corps of Engineers). 2006. Interim Regional Supplement to the Corps of Engineers Wetland Delineation Manual: Arid West Region. Ed, J.S. Wakely, R.W.

USGS (United States Geological Survey). *San Bernardino South, California 7.5-Minute Topographic Quadrangle Map*. Department of the Interior. U.S. Government Printing Office. Washington, D.C.

Web Soil Survey. Available online at <http://websoilsurvey.nrcs.usda.gov/>. Accessed December 2022.

FIGURE 1

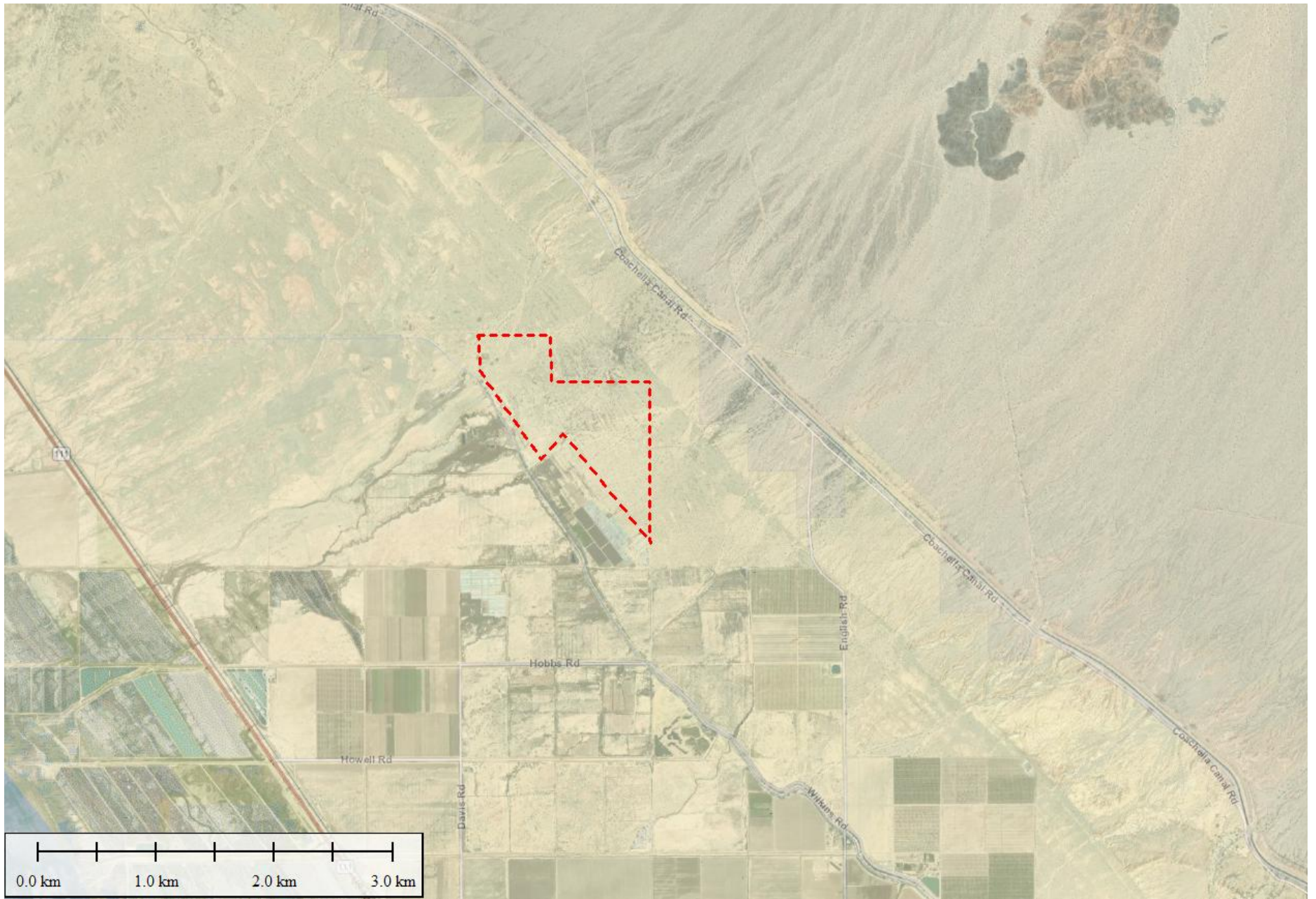

Location Map

Northstar 1
APNs 003-110-005 & -007
Imperial County, California

Legend

 Property Boundary



FIGURE 2



Vicinity Map

Northstar 1
 APNs 003-110-005 & -007
 Imperial County, California

Legend

 Property Boundary



FIGURE 3

APN: 003-110-005
111 ACRES

PROJECT GENTIE

161 KV N LINE

NORTHSTAR 1

CONFIDENTIAL DOCUMENTS
THE INFORMATION EMBODIED ON THIS DRAWING IS STRICTLY CONFIDENTIAL AND IS SUPPLIED WITH THE UNDERSTANDING THAT IT WILL BE HELD CONFIDENTIAL AND NOT DISCLOSED TO THIRD PARTIES WITHOUT THE PRIOR WRITTEN CONSENT OF ZGLOBAL, INC.

REV.	BY	DESCRIPTION	DATE	APPRD BY
0	RO	SUBMITTAL #1	2/24/22	HP

1 inch

Scale to Confirm 24"x36" Plot



604 SUTTER ST, STE 250
FOLSOM, CA 95630
Phone : 916.985.9461
Fax: 916.985.9467

"THESE DRAWINGS AND SPECIFICATIONS HAVE BEEN PREPARED BY ZGLOBAL INC. FOR THEIR EXCLUSIVE USE IN ACCORD WITH SEC. 6737.3 OF THE 2012 PROFESSIONAL ENGINEERS ACT OF THE STATE OF CALIFORNIA"

SHEET TITLE:

DRAWN BY:	RO	DRAWING No.	
CHECKED:	HP		
SCALE:			
JOB NO:			
DATE:		REV No.	1

NORTHSTAR - 1

APN: 003-110-007
176 ACRES

DC SYSTEM SIZE	71.1 MW	PITCH	17 FT	PV INVERTER	Sungrow 2500KW
AC SYSTEM SIZE	50 MW PV	MODULE	CHSM66M(DG)/F-BH 645	# OF PV INVERTER	20
DC STORAGE SIZE	75 MW	# OF MODULES	110,250	BATT INVERTER	TBD
ARRAY TYPE	TRACKER	STRING SIZE	30	# OF BATT INVERTER	TBD
UTILITY	IID	# OF STRINGS	3675	PV ENERGY MWH / YR	155,663

FIGURE 4

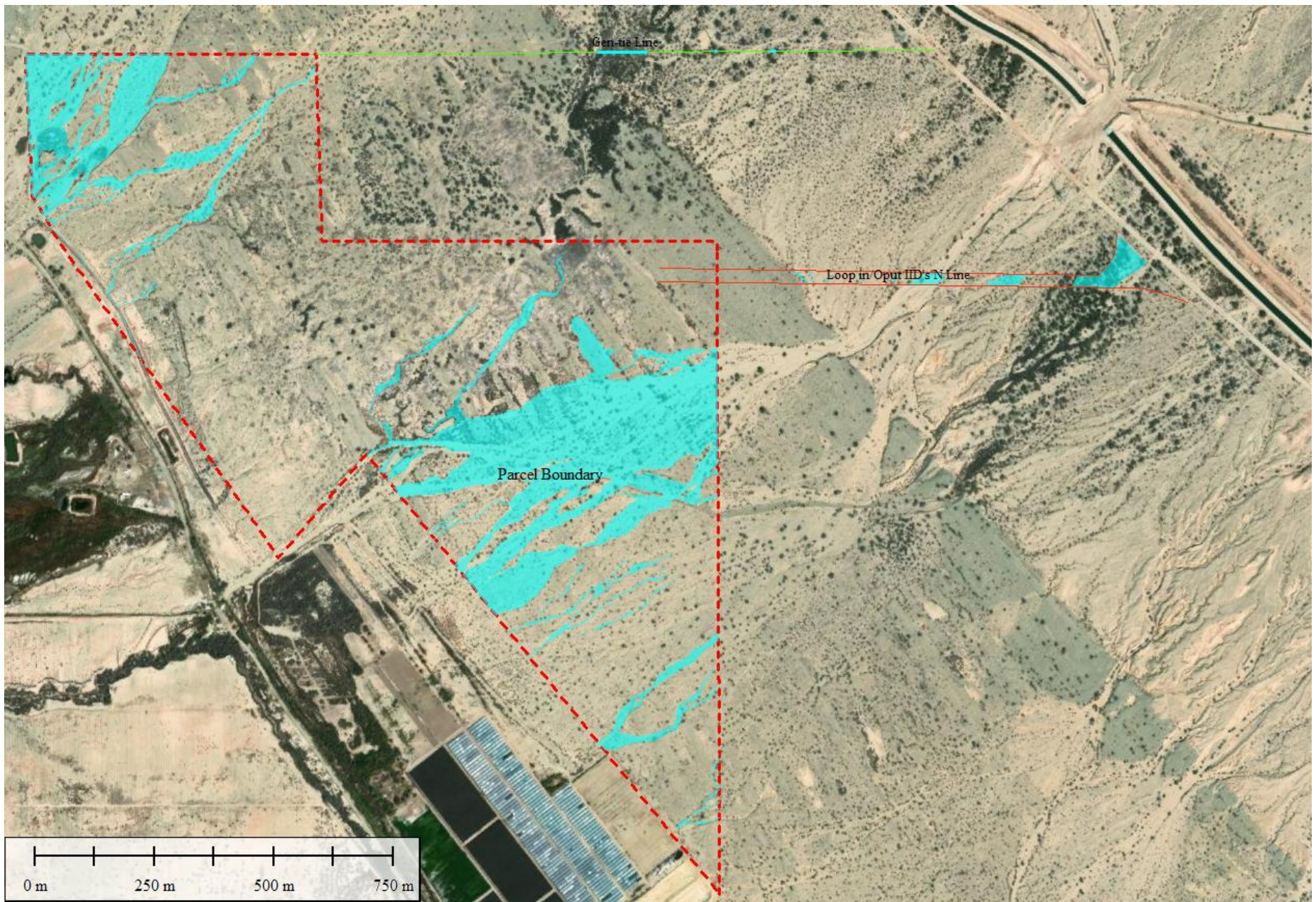

CDFW Jurisdiction

North Star 1
 APNs 003-110-005 & -007
 Imperial County, California

Legend



-  Property Boundary
-  CDFW (66.27 acres)



FIGURE 5

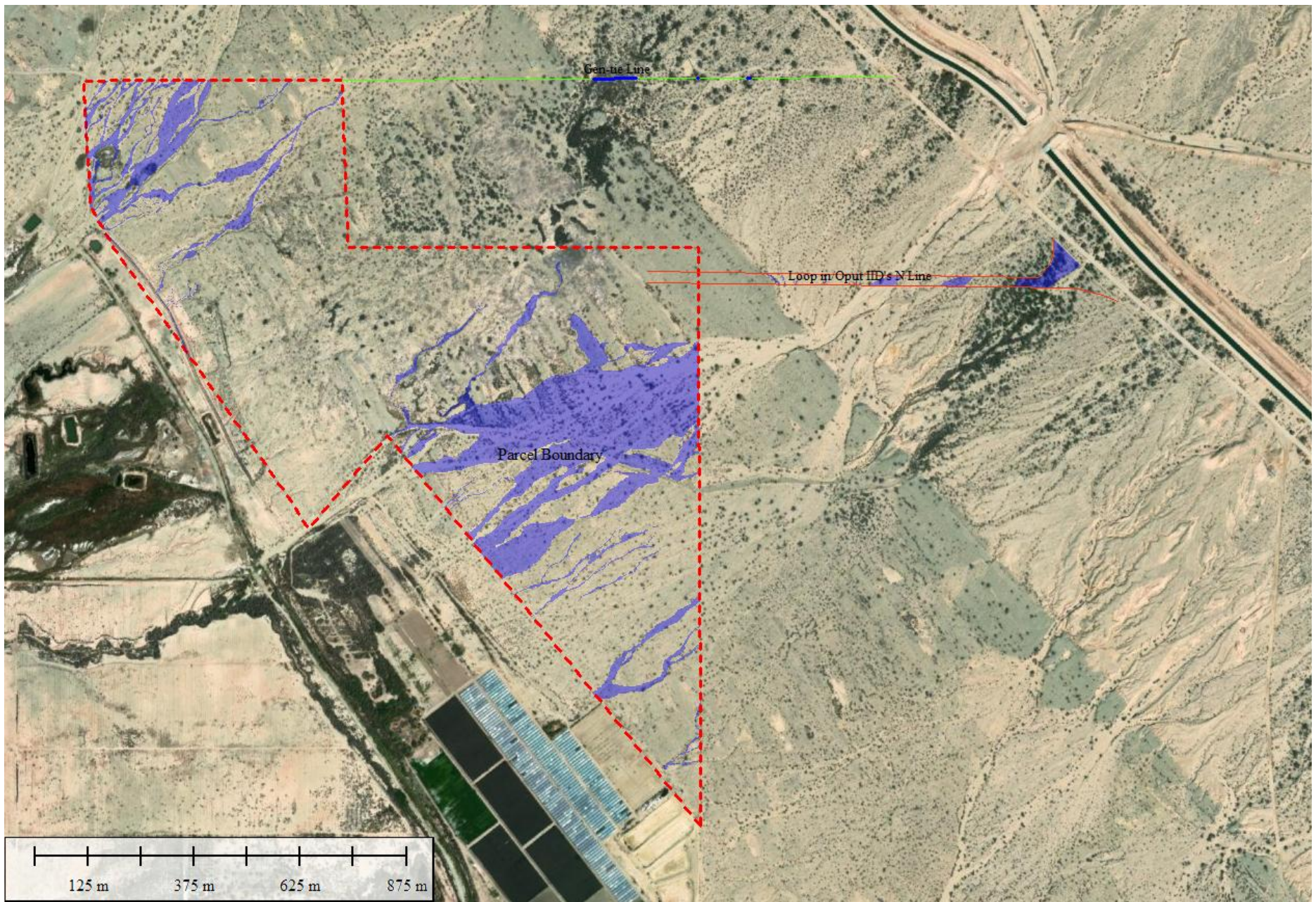

Waters of the United States

North Star 1
 APNs 003-110-005 & -007
 Imperial County, California

Legend



Property Boundary



Waters of the United States (59.06 acres)



N
 Hernandez
 Environmental
 Services

FIGURE 6

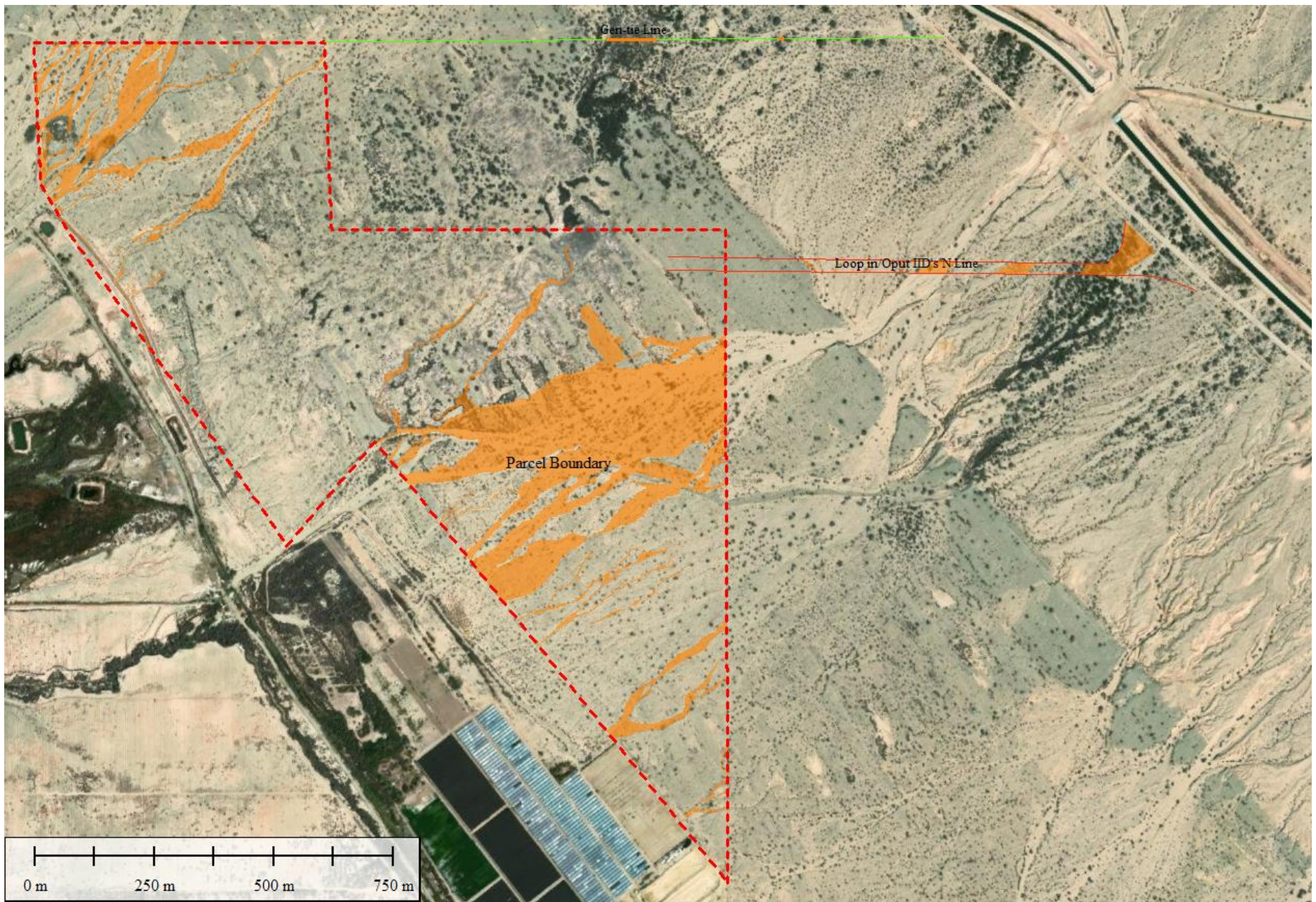

Waters of the State

North Star 1
 APNs 003-110-005 & -007
 Imperial County, California

Legend



Property Boundary



Waters of the State (59.34 acres)



FIGURE 7

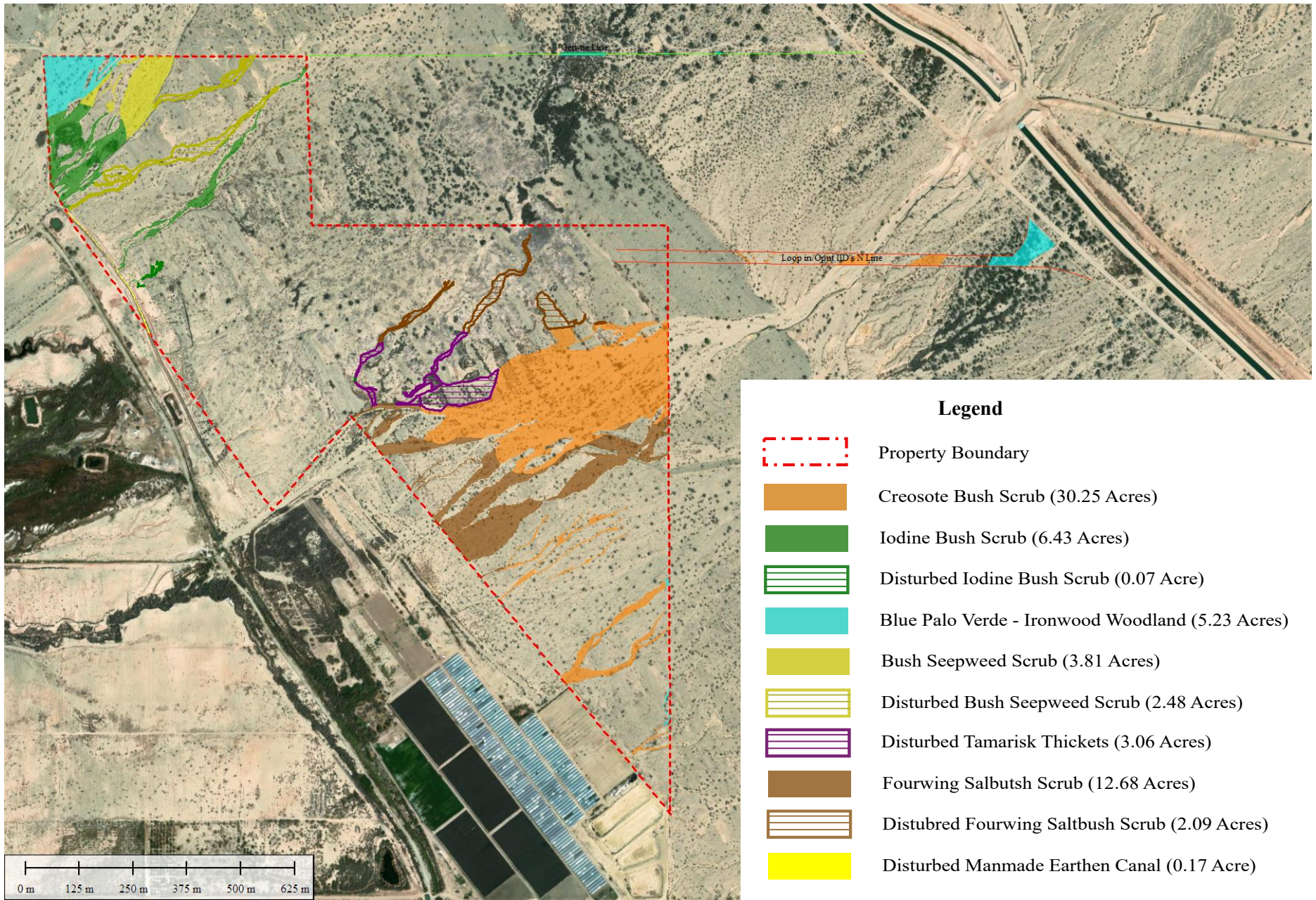

CDFW Jurisdiction Habitats

North Star 1

APNs 003-110-005 & -007

Imperial County, California



APPENDIX A



View of fork within ephemeral stream onsite.
View looking southwest.



View of braided channel throughout center
of the site. View looking west.



View of desert pavement followed by
ironwood. View looking west.



View of five-foot, two inches bank. View looking north.



View of desert wash followed by Chocolate Mountains in the distance. View looking northeast.



View of area affected by previous fire. View looking east.



View of manmade canal on northwest portion of the site. View looking southwest.



View of desert wash with bank containing exposed ironwood roots. View looking west.

APPENDIX B

Soil Map—Colorado Desert Area, California; and Imperial County, California, Imperial Valley Area
(Property Boundary)

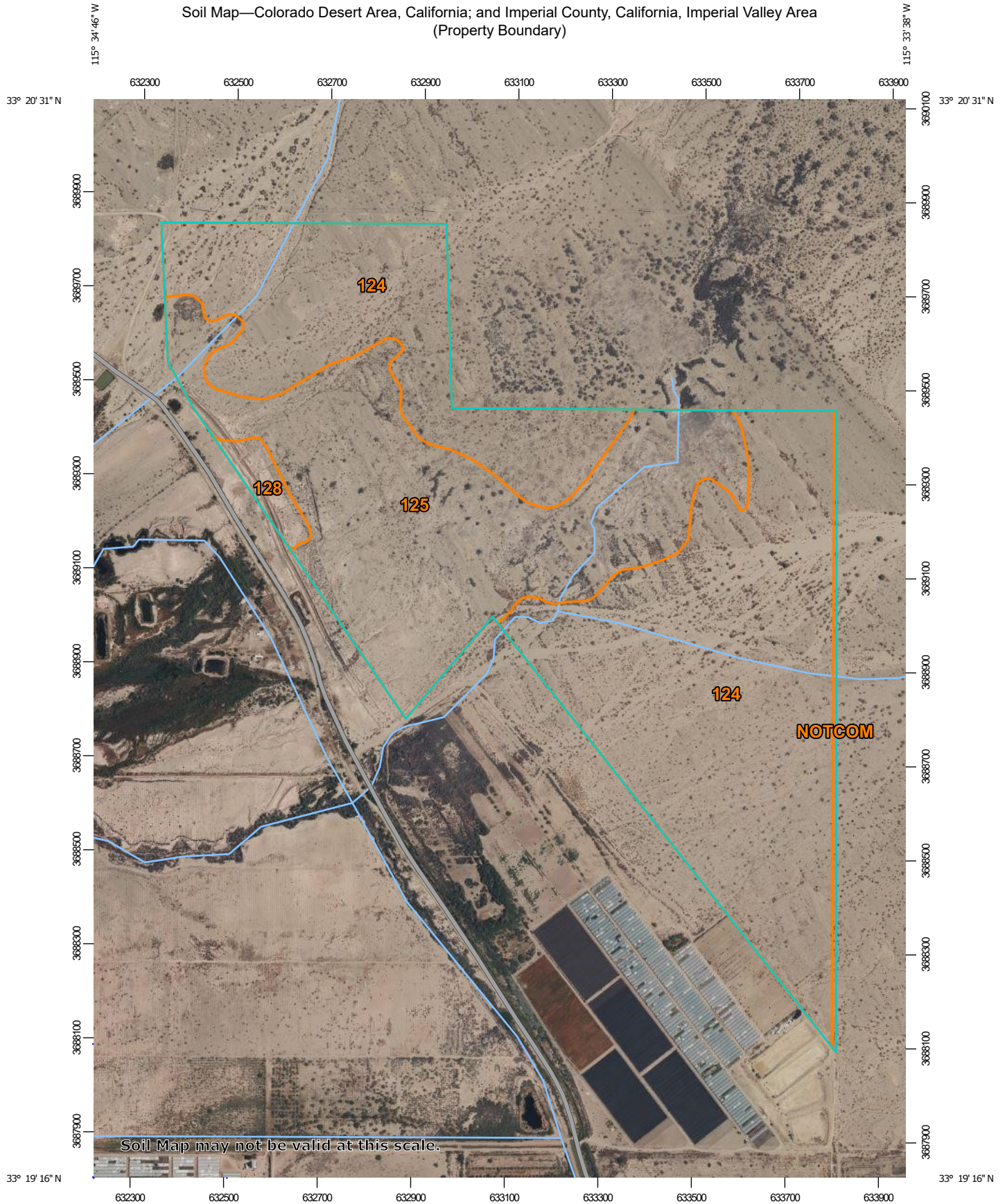

Soil Map may not be valid at this scale.

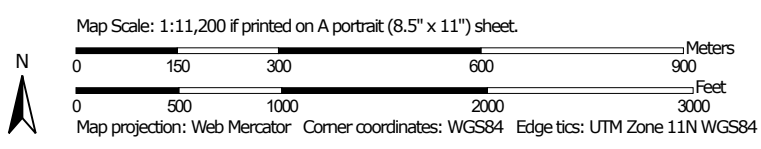

MAP LEGEND

Area of Interest (AOI)

 Area of Interest (AOI)

Soils

 Soil Map Unit Polygons

 Soil Map Unit Lines

 Soil Map Unit Points

Special Point Features



Blowout



Borrow Pit



Clay Spot



Closed Depression



Gravel Pit



Gravelly Spot



Landfill



Lava Flow



Marsh or swamp



Mine or Quarry



Miscellaneous Water



Perennial Water



Rock Outcrop



Saline Spot



Sandy Spot



Severely Eroded Spot



Sinkhole



Slide or Slip



Sodic Spot



Spoil Area



Stony Spot



Very Stony Spot



Wet Spot



Other



Special Line Features

Water Features



Streams and Canals

Transportation



Rails



Interstate Highways



US Routes



Major Roads



Local Roads

Background



Aerial Photography

MAP INFORMATION

The soil surveys that comprise your AOI were mapped at 1:24,000.

Warning: Soil Map may not be valid at this scale.

Enlargement of maps beyond the scale of mapping can cause misunderstanding of the detail of mapping and accuracy of soil line placement. The maps do not show the small areas of contrasting soils that could have been shown at a more detailed scale.

Please rely on the bar scale on each map sheet for map measurements.

Source of Map: Natural Resources Conservation Service

Web Soil Survey URL:

Coordinate System: Web Mercator (EPSG:3857)

Maps from the Web Soil Survey are based on the Web Mercator projection, which preserves direction and shape but distorts distance and area. A projection that preserves area, such as the Albers equal-area conic projection, should be used if more accurate calculations of distance or area are required.

This product is generated from the USDA-NRCS certified data as of the version date(s) listed below.

Soil Survey Area: Colorado Desert Area, California

Survey Area Data: Version 10, Sep 14, 2022

Soil Survey Area: Imperial County, California, Imperial Valley Area

Survey Area Data: Version 14, Sep 1, 2022

Your area of interest (AOI) includes more than one soil survey area. These survey areas may have been mapped at different scales, with a different land use in mind, at different times, or at different levels of detail. This may result in map unit symbols, soil properties, and interpretations that do not completely agree across soil survey area boundaries.

Soil map units are labeled (as space allows) for map scales 1:50,000 or larger.

Date(s) aerial images were photographed: Feb 6, 2021—May 29, 2021

MAP LEGEND

MAP INFORMATION

The orthophoto or other base map on which the soil lines were compiled and digitized probably differs from the background imagery displayed on these maps. As a result, some minor shifting of map unit boundaries may be evident.

Map Unit Legend

Map Unit Symbol	Map Unit Name	Acres in AOI	Percent of AOI
NOTCOM	No Digital Data Available	2.4	0.8%
Subtotals for Soil Survey Area		2.4	0.8%
Totals for Area of Interest		285.9	100.0%

Map Unit Symbol	Map Unit Name	Acres in AOI	Percent of AOI
124	Niland gravelly sand	179.5	62.8%
125	Niland gravelly sand, wet	99.5	34.8%
128	Niland-Imperial complex, wet	4.5	1.6%
Subtotals for Soil Survey Area		283.5	99.2%
Totals for Area of Interest		285.9	100.0%

Biological Technical Report for the North Star 1 Project

Imperial County, California

Prepared for:

ZGlobal, Inc.
604 Sutter Street, Suite 250
Folsom, California 95630

Submitted by:

 **ECORP Consulting, Inc.**
ENVIRONMENTAL CONSULTANTS
2525 Warren Drive
Rocklin, California 95677

February 28, 2023

CONTENTS

1.0 INTRODUCTION 1

 1.1 Purpose of the Report..... 1

 1.2 Terms 1

 1.3 Project Location and Description..... 1

2.0 REGULATORY CONSIDERATIONS 5

 2.1 Federal Regulations..... 5

 2.1.1 Endangered Species Act 5

 2.1.2 Migratory Bird Treaty Act..... 5

 2.1.3 Clean Water Act 5

 2.2 State and Local Regulations 6

 2.2.1 California Endangered Species Act..... 6

 2.2.2 Fully Protected Species 7

 2.2.3 Native Plant Protection Act 7

 2.2.4 Porter Cologne Water Quality Control Act 7

 2.2.5 California Fish and Game Code 8

 2.2.6 Conservation and Open Space Element..... 8

 2.2.7 Desert Renewable Energy Conservation Plan Use Plan 8

 2.2.8 Imperial Irrigation District Water Conservation and Transfer Project and Draft
Habitat Conservation Plan Draft Environmental Impact Report/Environmental
Impact Statement..... 9

 2.2.9 California Environmental Quality Act Significance Criteria 9

3.0 METHODS 10

 3.1 Literature Review..... 10

 3.1.1 Sensitive Plant Communities..... 10

 3.1.2 Special Status Species..... 11

 3.2 Field Survey 13

 3.2.1 Small Unmanned Aircraft System Survey and Vegetation Mapping 13

 3.2.2 Biological Reconnaissance Survey 13

 3.2.3 Vegetation Mapping 14

 3.2.4 Aquatic Resources Delineation 14

 3.3 Potential for Occurrence Determinations..... 14

4.0 RESULTS..... 15

 4.1 Literature Review..... 15

 4.1.1 Special-Status Plants and Wildlife 15

 4.1.2 U.S. Fish and Wildlife Service Designated Critical Habitat 15

4.2	Biological Reconnaissance Survey.....	15
4.2.1	Property Characteristics.....	16
4.2.2	Vegetation Communities/Land Use.....	18
4.2.3	Other Land Cover Types within the Survey Area.....	22
4.2.4	Wildlife Observed.....	23
4.3	Special-Status Species Assessment.....	23
4.3.1	Plants.....	25
4.3.2	Wildlife.....	26
4.4	Jurisdictional Aquatic Resources Assessment.....	31
4.5	Wildlife Movement Corridors, Linkages, and Significant Ecological Areas.....	31
5.0	PROJECT IMPACTS.....	32
5.1.1	Special-Status Species.....	32
5.1.2	Sensitive Natural Communities.....	33
5.1.3	State- and/or Federally Protected Wetlands and Waters.....	34
5.1.4	Wildlife Corridors and Nursery Sites.....	34
5.1.5	Habitat and Conservation Plans and Natural Community Conservation.....	34
6.0	RECOMMENDATIONS AND MITIGATION MEASURES.....	34
7.0	CERTIFICATION.....	38
8.0	REFERENCES.....	39

LIST OF TABLES

Table 1.	U.S. Geological Survey Quadrangle Information.....	4
Table 2.	Weather Conditions During the Survey.....	16
Table 3.	Vegetation Communities and Land Cover Types in Survey Area.....	18
Table 4.	California Native Plant Society Status Designations.....	25
Table 5.	Wildlife Status Designations.....	27

LIST OF FIGURES

Figure 1.	Project Vicinity.....	2
Figure 2.	Project Location.....	3
Figure 3.	Natural Resources Conservation Service Soil Types.....	17
Figure 4.	Vegetation Communities and Land Cover Types.....	19
Figure 5.	Special-Status Species Observations.....	24

LIST OF APPENDICES

- Appendix A – Representative Site Photographs
- Appendix B – Special-Status Plant Potential For Occurrence
- Appendix C – Special-Status Wildlife Potential For Occurrence
- Appendix D – Plant Species Observed
- Appendix E – Wildlife Species Observed

LIST OF ACRONYMS AND ABBREVIATIONS

Term	Definition
ACE	Areas of Conservation Emphasis
ACEC	Areas of Critical Environmental Concern
amsl	Above Mean Sea Level
AOU	American Ornithologists’ Union
BESS	Battery Electric Storage System
BIOS	Biogeographic Information and Observation System
BLM	United States Bureau of Land Management
CCR	California Code of Regulations
CDFG	California Department of Fish and Game
CDFW	California Department of Fish and Wildlife
CEQA	California Environmental Quality Act
CFR	Code of Federal Regulations
CNDDDB	California Natural Diversity Data Base
CNPS	California Native Plant Society
CRPR	California Rare Plant Rank
CNPSEI	CNPS Electronic Inventory
CUP	Conditional Use Permit
CWA	Clean Water Act
DRECP	Desert Renewable Energy Conservation Plan
ESA	Endangered Species Act
GIS	Geographic Information System
GPS	Global Positioning System
HCP	Habitat Conservation Plan
IID	Imperial Irrigation District
MBTA	Migratory Bird Treaty Act
MW	Megawatt
NPPA	Native Plant Protection Act
NRCS	Natural Resources Conservation Service
Project	North Star 1 Solar Project
PG&E	Pacific Gas & Electric Company
RE Overlay Zone	Renewable Energy and Transmission Element
RWQCB	Regional Water Quality Control Board (Colorado River Basin)
SAA	Streambed Alteration Agreement
SSAR	Society for the Study of Amphibians and Reptiles
SSC	Species of Special Concern

Term	Definition
sUAS	Small unmanned aircraft system
USACE	U.S. Army Corps of Engineers
USC	U.S. Code
USEPA	U.S. Environmental Protection Agency
USFWS	U.S. Fish and Wildlife Service
USGS	U.S. Geological Survey

1.0 INTRODUCTION

The North Star 1 Project (Project) consists of a 50-megawatt (MW) solar field, consisting of 110,250 modules on 3,675 strings and associated collector and inverter facilities, and a 75-MW Battery Electric Storage System (BESS) located on approximately 286 acres of vacant land on two parcels in Imperial County, California. ECORP Consulting, Inc. conducted a literature review, vegetation mapping and a biological resource assessment survey, aquatic resource delineation, and a small unmanned aircraft system (sUAS) survey of the Survey Area, which includes the Project Site plus a 500-foot buffer, to document the existing biological resources, assess the habitat for its potential to support sensitive plant and wildlife species, and, as required under the California Environmental Quality Act (CEQA), determine whether Project-related impacts would occur to sensitive biological resources.

1.1 Purpose of the Report

ECORP prepared this report to describe biological resources within the Project Site and to support Project review under CEQA. Assessment of potential occurrences of special-status plants and animals is based on habitat, geographic and elevational range, and data from field surveys conducted by ECORP in 2022.

1.2 Terms

The following terms will be used throughout this document and are defined as follows:

- *Project Site*: the approximately 286 acres subject to general assessment during the biological survey; includes the solar field and the gen-tie line. These areas are potentially subject to permanent and temporary impacts.
- *Gen-tie line*: the approximately 0.8 mile of gen-tie line (estimated to be approximately 90 feet wide). These areas are potentially subject to permanent and temporary impacts.
- *Survey Area*: includes the Project Site, gen-tie line and a 500-foot buffer around the Project Site, these areas are potentially subject to temporary impacts.

1.3 Project Location and Description

The Proposed Project is located on approximately 286 acres of vacant land on two parcels near the Salton Sea in Imperial County, California (Assessor Parcel Numbers 025-260-011, 025-010-006, and 025-270-023). The Project is approximately 7 miles north of the community of Niland, California, 2 miles northeast of the community of Wister, and 2 miles east of Highway 111 (Figure 1). It is adjacent to the Coachella Canal to the northeast. Site access would be available from Highway 111 on the east and north via local roads (Figure 2). A complete summary of geographic information for the Project Site is provided in Table 1.



Location: N:\2022\2022-102 NorthStar_1\WAPS\Location_Vicinity\NorthStar_1_LnVaprx - NorthStar_1_Vicinity (trotellini - 11/30/2022)

Map Date: 11/22/2022

Service Layer Credits: California State Parks, Esri, HERE, Garmin, SafeGraph, FAO, METI/NASA, USGS, Bureau of Land Management, EPA, NPS, Esri, CGIAR, USGS, Esri, Garmin, FAO, NOAA, USGS, EPA, Esri, USGS

Figure 1. Project Vicinity

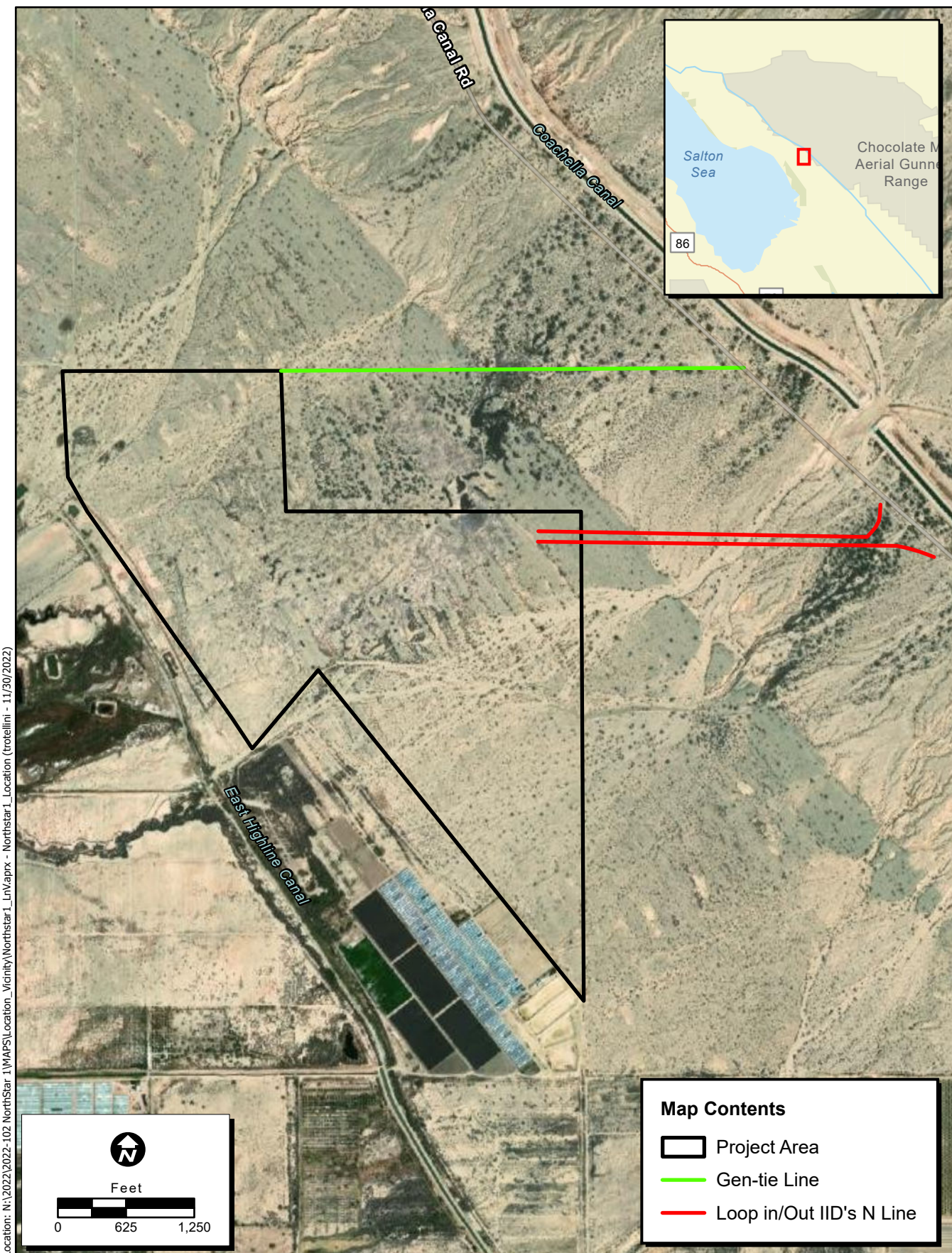

Location: N:\2022\2022-102 North Star 1\WAPS\Location_Vicinity\Northstar1_Ln\Vaprx - Northstar1_Location (trotellini - 11/30/2022)

Map Date: 11/30/2022

Service Layer Credits: California State Parks, Esri, HERE, Garmin, FAO, NOAA, USGS, Bureau of Land Management, EPA, NPS, Esri Community Maps Contributors, California State Parks, Esri, HERE, Garmin, SafeGraph, GeoTechnologies, Inc., METINASA, USGS, Bureau of Land Management, EPA, NPS, US Census Bureau, USDA, Maxar

Figure 2. Project Location

Table 1. U.S. Geological Survey Quadrangle Information				
USGS 7.5-Minute Quad Map Name	Township	Range	Section(s)	Approximate Center of Survey Area
Wister	10S	13E	1	33.333677°, -115.567287°
		14E	6	

USGS = U.S. Geological Survey

The site is currently vacant undeveloped land, and is surrounded by open space to the east and north, and active agriculture to the south and west. Topography at the Project Site is relatively flat with elevations ranging between -67 and 72 feet Above Mean Sea Level (amsl). The site lies between the Coachella Valley Canal 494 to the northeast and East Highline Canal to the southwest.

ZGlobal will construct two solar fields, each with a BESS located on two vacant land parcels of approximately 286 acres in Imperial County, California. In addition, the Project will construct an offsite generation tie (gen-tie) line approximately 0.8-mile (estimated to be approximately 90 feet wide) route eastward towards Coachella Canal Road, on lands administered by the Bureau of Land Management (BLM) El Centro Field Office. The facility is expected to produce approximately 3,675 MW/year of energy for delivery to the Imperial Irrigation District.

ZGlobal proposed to connect the Project to the Pacific Gas & Electric Company (PG&E) grid offsite through one of two possible gen-tie lines to PG&E's 161 kV N transmission line near the Coachella Canal; the northern option would extend approximately 0.8 mile from the northeast corner of the 110-005 parcel, and the southern option would extend approximately 0.6 mile from the northeast corner of the 110-007 parcel.

The Proposed Project is within an Imperial County General Plan-designated Agricultural area and is zoned S-2 (Open Space/Preservation), which allows solar generating facilities with a Conditional Use Permit (CUP). The California Department of Conservation's Imperial County Important Farmland Map (2018) categorizes the parcels as *Other Land*, indicating they are not considered important farmland under any category (i.e., Prime Farmland, Farmland of Statewide Importance, Unique Farmland, or Farmland of Local Importance). Parcel 110-005 is within the County's Renewable Energy and Transmission Element (RE Overlay Zone) but parcel 110-007 is not. An amendment to the County's General Plan will be needed to include and classify the Project Site within the RE Overlay Zone, and a CUP to allow construction and operation of the solar energy generation facility with battery storage within the RE Overlay Zone will be required to implement the Project.

ECORP conducted the biological reconnaissance survey to identify potential constraints and to ensure compliance with state and federal regulations regarding listed, protected, and sensitive species. The regulations are detailed below.

2.0 REGULATORY CONSIDERATIONS

ECORP conducted the biological reconnaissance survey to identify potential constraints and to ensure compliance with state and federal regulations regarding listed, protected, and sensitive species. The regulations are detailed below.

2.1 Federal Regulations

2.1.1 Endangered Species Act

The federal Endangered Species Act (ESA) protects plants and animals that are listed as endangered or threatened by the U.S. Fish and Wildlife Service (USFWS) and the National Marine Fisheries Service. Section 9 of the ESA prohibits the take of endangered wildlife, where *take* is defined as “harass, harm, pursue, hunt, shoot, wound, kill, trap, capture, collect, or attempt to engage in such conduct” (50 Code of Federal Regulations [CFR] 17.3). For plants, this statute governs removing, possessing, maliciously damaging, or destroying any endangered plant on federal land and removing, cutting, digging up, damaging, or destroying any endangered plant on non-federal land in knowing violation of state law (16 U.S. Code [USC] 1538). Under Section 7 of the ESA, federal agencies are required to consult with the USFWS if their actions, including permit approvals or funding, could adversely affect a listed or proposed species (including plants) or its critical habitat. Through consultation and the issuance of a biological opinion, the USFWS may issue an incidental take statement allowing take of the species that is incidental to an otherwise authorized activity, provided the activity will not jeopardize the continued existence of the species. Section 10 of the ESA provides for issuance of incidental take permits where no other federal actions are necessary provided a habitat conservation plan (HCP) is developed.

2.1.2 Migratory Bird Treaty Act

The Migratory Bird Treaty Act (MBTA) implements international treaties between the U.S. and other nations devised to protect migratory birds, any of their parts, eggs, and nests from activities such as hunting, pursuing, capturing, killing, selling, and shipping, unless expressly authorized in the regulations or by permit. As authorized by the MBTA, the USFWS issues permits to qualified applicants for the following types of activities: falconry, raptor propagation, scientific collecting, special purposes (rehabilitation, education, migratory game bird propagation, and salvage), take of depredating birds, taxidermy, and waterfowl sale and disposal. The regulations governing migratory bird permits can be found in 50 CFR Part 13 General Permit Procedures and 50 CFR Part 21 Migratory Bird Permits. The State of California has incorporated the protection of birds of prey in Sections 3800, 3513, and 3503.5 of the California Fish and Game Code.

2.1.3 Clean Water Act

The U.S. Army Corps of Engineers (USACE) regulates discharge of dredged or fill material into Waters of the U.S. under Section 404 of the federal Clean Water Act (CWA). *Discharges of fill material* is defined as the addition of fill material into Waters of the U.S., including, but not limited to the following: placement of fill necessary for the construction of any structure, or impoundment requiring rock, sand, dirt, or other

material for its construction; site development fills for recreational, industrial, commercial, residential, and other uses; causeways or road fills; and fill for intake and outfall pipes, and subaqueous utility lines [33 Code of Federal Regulations (CFR) Section 328.2(f)]. In addition, Section 401 of the CWA (33 USC 1341) requires any applicant for a federal license or permit to conduct any activity that may result in a discharge of a pollutant into Waters of the U.S. to obtain a certification that the discharge will comply with the applicable effluent limitations and water quality standards. Section 401 Certification, "gives states and authorized tribes the authority to grant or waive certification of proposed federal licenses or permits that may discharge into waters of the US" (33 USC 1251).

The U.S. Environmental Protection Agency (USEPA) and the Department of the Army published a proposed rule to revise the definition of *Waters of the U.S.* in August 2021. The proposed rule was open for public comment until February 7, 2022. A final rule has not yet been published. In the rule, which follows previous USACE/USEPA CWA regulations (33 CFR 328.3[a]), the term *Waters of the U.S.* is defined as follows:

1. All waters which are currently used, or were used in the past, or may be susceptible to use in interstate or foreign commerce, including all waters which are subject to the ebb and flow of the tide;
2. All interstate waters including interstate wetlands;
3. All other waters such as intrastate lakes, rivers, streams (including intermittent streams), mudflats, sandflats, wetlands, sloughs, prairie potholes, wet meadows, playa lakes, or natural ponds, the use, degradation or destruction of which could affect interstate or foreign commerce including any such waters: (i) Which are or could be used by interstate or foreign travelers for recreational or other purposes; or (ii) From which fish or shellfish are or could be taken and sold in interstate or foreign commerce; or (iii) Which are used or could be used for industrial purpose by industries in interstate commerce;
4. All impoundments of waters otherwise defined as waters of the U.S. under the definition;
5. Tributaries of waters identified in paragraphs (a)(1)-(4) of this section;
6. The territorial seas;
7. Wetlands adjacent to waters (other than waters that are themselves wetlands) identified in 1 through 6 above.

2.2 State and Local Regulations

2.2.1 California Endangered Species Act

The California ESA generally parallels the main provisions of the ESA but, unlike its federal counterpart, the California ESA applies the take prohibitions to species proposed for listing (called *candidates* by the State). Section 2080 of the California Fish and Game Code prohibits the taking, possession, purchase, sale, and import or export of endangered, threatened, or candidate species, unless otherwise authorized by permit or in the regulations. Take is defined in Section 86 of the California Fish and Game Code as "hunt,

pursue, catch, capture, or kill, or attempt to hunt, pursue, catch, capture, or kill.” The California ESA allows for take incidental to otherwise lawful development projects. State lead agencies are required to consult with California Department of Fish and Wildlife (CDFW) to ensure that any action they undertake is not likely to jeopardize the continued existence of any endangered or threatened species or result in destruction or adverse modification of essential habitat.

2.2.2 Fully Protected Species

The State of California first began to designate species as *fully protected* prior to the creation of the federal and California ESAs. Lists of fully protected species were initially developed to provide protection to those animals that were rare or faced possible extinction, and included fish, amphibians and reptiles, birds, and mammals. Most fully protected species have since been listed as threatened or endangered under federal and/or California ESAs. The regulations that implement the Fully Protected Species Statute (California Fish and Game Code Section 4700) provide that fully protected species may not be taken or possessed at any time. Furthermore, CDFW prohibits any State agency from issuing incidental take permits for fully protected species, except for necessary scientific research.

2.2.3 Native Plant Protection Act

The Native Plant Protection Act (NPPA) of 1977 (California Fish and Game Code Sections 1900-1913) was created with the intent to “preserve, protect and enhance rare and endangered plants in this State.” The NPPA is administered by CDFW. The Fish and Wildlife Commission has the authority to designate native plants as *endangered* or *rare* and to protect endangered and rare plants from take. The California ESA of 1984 (California Fish and Game Code Sections 2050-2116) provided further protection for rare and endangered plant species, but the NPPA remains part of the California Fish and Game Code.

2.2.4 Porter Cologne Water Quality Control Act

The Porter-Cologne Water Quality Control Act requires “any person discharging waste, or proposing to discharge waste, within any region that could affect the waters of the State to file a report of discharge” with the Regional Water Quality Control Board (RWQCB) through State Wetland Definition and Procedures for Discharges of Dredged or Fill Material to Waters of the State (Procedures) (California Code of Regulations [CCR], Title 23, and 3855) (State Water Resources Control Board 2021). *Waters of the State* is defined as any surface water or groundwater, including saline waters, within the boundaries of the state (California Water Code Section 13050[e]). Pollution is defined as an alteration of the quality of the Waters of the State by waste to a degree that unreasonably affects its beneficial uses (California Water Code Section 13050) and includes filling in Waters of the State. Note that CCR, Title 23, Section 3855 applies only to individual water quality certifications, but the new Procedures extend the application of Section 3855 to individual waste discharge requirements for discharges of dredged or fill material to Waters of the State and waivers thereof.

A permit for impacts to Waters of the State would likely be required under the CWA and/or Porter-Cologne Water Quality Control Act. The RWQCB considers whether project activities could impact the quality of Waters of the State to determine if a project should be regulated pursuant to the Porter-Cologne Water Quality Control Act.

2.2.5 California Fish and Game Code

2.2.5.1 Streambed Alteration Agreement

Section 1602 of the California Fish and Game Code requires that a Notification of Lake or Streambed Alteration be submitted to CDFW for “any activity that may substantially divert or obstruct the natural flow or substantially change the bed, channel, or bank of any river, stream, or lake.” The CDFW reviews the proposed actions and, if necessary, submits to the Applicant a proposal for measures to protect affected fish and wildlife resources. The final proposal that is mutually agreed upon by CDFW and the Applicant is the Streambed Alteration Agreement (SAA). Often, projects that require an SAA also require a permit from the USACE under Section 404 of the CWA. The conditions of the Section 404 permit and the SAA may overlap in these instances

2.2.5.2 Migratory Birds

The CDFW enforces the protection of nongame native birds in Sections 3503, 3503.5, and 3800 of the California Fish and Game Code. Section 3513 of the California Fish and Game Code prohibits the possession or take of birds listed under the MBTA. These sections mandate the protection of California nongame native birds’ nests and also make it unlawful to take these birds. All raptor species are protected from take pursuant to California Fish and Game Code Section 3503.5 and are also protected at the federal level by the MBTA of 1918 (USFWS 1918).

2.2.6 Conservation and Open Space Element

Imperial County created the Conservation and Open Space Element (2006) to provide details and measures for management and preservation of biological resources as well as various other resources (i.e., cultural, soils, minerals). This plan focuses on protecting scarce resources and preventing wasteful exploitation, neglect, and destruction of California’s natural resources. The plan outlines areas with sensitive habitat and sensitive species, also labelled *Resource Areas*. Open space easements and protection of riparian habitat, rock outcrops, California fan palm oases, and wildlife corridors are also discussed in the plan. As it currently stands, the open space element follows CEQA guidelines with special focus on its scarce resources.

2.2.7 Desert Renewable Energy Conservation Plan Use Plan

The Desert Renewable Energy Conservation Plan (DRECP) is designed to provide effective protection and conservation of desert ecosystems while allowing for the appropriate development of renewable energy projects. The DRECP Area contains both federal and non-federal California desert land. Some of these lands are designated as California Desert Conservation Areas. The federal portion of the plan area was released by the BLM as a Land Use Plan Amendment. The DRECP Land Use Plan Amendment supports the conservation goals of the DRECP and organizes land into ecoregions and subregions with specific management goals, objectives, allowable uses, and management actions for biological and cultural resources. The BLM designates Areas of Critical Environmental Concern (ACEC), where special management attention is needed to protect important historical, cultural, and scenic values, or fish and

wildlife or other natural resources. The BLM also designates Renewable Energy Development Focus Areas, which are on BLM-administered lands, within which solar, wind, and geothermal renewable energy development and associated activities are allowable uses and that have been determined to be of low or lower resource conflict. The intent is to incentivize and streamline such development in these areas. The Project is located in a DRECP Area but does not fall into an ACEC.

2.2.8 Imperial Irrigation District Water Conservation and Transfer Project and Draft Habitat Conservation Plan Draft Environmental Impact Report/Environmental Impact Statement

The Imperial Irrigation District (IID) HCP covers approximately 500,000 acres in Imperial County, as well as a small portion of Riverside County. The Planning Area includes the rights-of-way along the All-American Canal from the Imperial Dam on the Colorado River to its terminus near Calexico, and the IID service area from the US-Mexico border to the Salton Sea (including the rights-of-way along its canals).

This area provides habitat for 96 species-status species, including the California Species of Special Concern loggerhead shrike (*Lanius ludovicianus*) and the federal Species of Concern long-eared owl (*Asio otus*). Entities in the IID HCP include the IID, the CDFW, and the USFWS. The final HCP was published as of February 1, 2006.

2.2.9 California Environmental Quality Act Significance Criteria

Section 15064.7 of the CEQA Guidelines encourages local agencies to develop and publish the thresholds the agency uses in determining the significance of environmental effects caused by projects under its review. However, agencies may also rely upon the guidance provided by the expanded Initial Study checklist contained in Appendix G of the CEQA Guidelines. Appendix G provides examples of impacts that would normally be considered significant. Based on these examples, impacts to biological resources would normally be considered significant if the project would:

- have a substantial adverse effect, either directly or through habitat modifications, on any species identified as a candidate, sensitive, or special status species in local or regional plans, policies, or regulations, or by CDFW or USFWS;
- have a substantial adverse effect on any riparian habitat or other sensitive natural community identified in local or regional plans, policies, regulations or by CDFW or USFWS;
- have a substantial adverse effect on State or federally protected wetlands (including, but not limited to, marsh, vernal pool, and coastal) through direct removal, filling, hydrological interruption, or other means;
- interfere substantially with the movement of any native resident or migratory fish or wildlife species, or with established native resident or migratory wildlife corridors, or impede the use of native wildlife nursery sites;
- conflict with any local policies or ordinances protecting biological resources, such as a tree preservation policy or ordinance; and

- conflict with the provisions of an adopted HCP, Natural Community Conservation Plan, or other approved local, regional, or State HCP.

An evaluation of whether an impact on biological resources would be substantial must consider both the resource and how that resource fits into a regional or local context. Substantial impacts would be those that would diminish, or result in the loss of, an important biological resource, or those that would obviously conflict with local, state, or federal resource conservation plans, goals, or regulations. Impacts are sometimes locally important but not significant according to CEQA because although the impacts would result in an adverse alteration of existing conditions, they would neither substantially diminish nor result in the permanent loss of an important resource on a population- or region-wide basis.

3.0 METHODS

3.1 Literature Review

3.1.1 Sensitive Plant Communities

Sensitive plant communities (sensitive habitats) as defined below, are of limited distribution statewide or within a county or region and are often vulnerable to environmental effects of projects. Sensitive habitats are often threatened with local extirpation and are therefore considered as valuable biological resources. Plant communities are considered *sensitive* by the California Native Plant Society (CNPS) and CDFW if they meet any of the following criteria.

- The habitat is recognized and considered sensitive by CDFW, USFWS, and/or special interest groups such as CNPS.
- The habitat is under the jurisdiction of the USACE pursuant to Section 404 of the CWA.
- The habitat is under the jurisdiction of the CDFW pursuant to Sections 1600 through 1612 of the California Fish and Game Code.
- The habitat is known or believed to be of high priority for inventory in the California Natural Diversity Database (CNDDDB).
- The habitat is considered regionally rare.
- The habitat has undergone a large-scale reduction due to increased encroachment and development.
- The habitat supports special status plant and/or wildlife species (defined below).
- The habitat functions as an important corridor for wildlife movement.

The most current version of CDFW's List of California Sensitive Natural Diversity Database indicates which natural communities are sensitive given the current state of the California classification (CDFW 2022a).

3.1.2 Special Status Species

Species of plants and wildlife are afforded *special status* by federal agencies, state agencies, and/or non-governmental organizations (e.g., USFWS, CDFW, CNPS, BLM) because of their recognized rarity, potential vulnerability to extinction, and local importance. These species typically have a limited geographic range and/or limited habitat and are referred to collectively as *special-status* species. Plant and wildlife species are considered *special-status* species if they meet any of the following criteria:

- Taxa with official status under the federal and California ESAs, and/or the Native Plant Protection Act (NPPA).
- Taxa proposed for listing under the federal and/or California ESAs.
- Taxa designated a species of special concern or a state fully protected species by CDFW.
- Taxa identified as sensitive, unique or rare, by the USFWS, CDFW, and/or the BLM.
- Plants that meet the definition of rare or endangered under CEQA Section 15380(b) and (d). Species that may meet the definition of rare or endangered include the following:

Species considered by CNPS and CDFW to be “rare, threatened or endangered in California” (California Rare Plant Rank [CRPR] 1A, 1B and 2; CNPS 2022). A majority of the CRPR 3 and CRPR 4 plant species generally do not qualify for protection under the California ESA and NPPA.

Species that may warrant consideration on the basis of local significance or recent biological information.

Some species included on the CNDDDB Special Vascular Plants, Bryophytes, and Lichens List (CDFW 2022a).

- Considered a locally significant species, that is, a species that is not rare from a statewide perspective but is rare or uncommon in a local context such as within a county or region (CEQA Section 15125 (c)) or is so designated in local or regional plans, policies, or ordinances. Examples include a species at the outer limits of its known range or a species occurring on an uncommon soil type.

Available literature and databases were reviewed regarding sensitive habitats and special status species. Special status species that have the potential to occur within the immediate region of the Project Site were identified. Several agencies, including the USFWS, CDFW, and CNPS publish lists of particular taxa (species and subspecies) and the associated level of protection or concern associated with each. Reviewed and consulted literature and databases focused on the Project Site and included the following sources listed below:

- The CNDDDB, a CDFW species account database that inventories status and locations of rare plants and wildlife in California, was used to identify any sensitive plant communities and special status species that may exist within a 5-mile radius of the Project Site (CDFW 2022a);

- Online CNPS Inventory of Rare and Endangered Plants of California (CNPSEI; CNPS 2022). A search for species documented in areas depicted on the USGS 7.5-Minute Wister, Frink, Frink NE, Frink NW, Iris, Iris Pass, Iris Wash, Obsidian Butte, and Niland topographic quadrangles. The CNDDDB and CNPSEI contain records of reported occurrences of federally or state-listed endangered, threatened, proposed endangered or threatened species, California Species of Special Concern (SSC), and other special-status species or habitat that may occur within or in the vicinity of the Project.
- A map of USFWS critical habitat to determine species with critical habitat mapped in the general vicinity of the Project (USFWS 2022a).
- Pertinent maps, scientific literature, websites, and regional flora and fauna field guides.

Additional information was gathered from the following sources and includes, but is not limited to:

- U.S. Department of Agriculture, Natural Resources Conservation Service (NRCS) *Web Soil Survey* (NRCS 2022a);
- Biogeographic Information and Observation System (BIOS, CDFW 2022b)
- *Special Animals List* (CDFW 2022c);
- *State and Federally Listed Endangered and Threatened Animals of California* (CDFW 2022d);
- *The Jepson Manual: Vascular Plants of California* (Baldwin et al. 2012);
- *The Manual of California Vegetation*, 2nd Edition (Sawyer et al. 2009); and
- various online websites (e.g., CalFlora 2022).

In addition to the database searches, ECORP biologists also reviewed nearby records on iNaturalist, a citizen science network that displays location, notes, and activity of plant and wildlife observations. iNaturalist is a collaboration between the California Academy of Sciences and the National Geographic Society (iNaturalist 2022). Although iNaturalist is not a peer-reviewed resource, observations can be considered *Research Grade* after multiple members agree on a species identification. ECORP biologists also reviewed eBird observations of special status bird species that appeared in the literature review.

The literature review provided a baseline from which to inventory the biological resources potentially occurring within the Survey Area. Although the inventory list of special status wildlife species was not exhaustive of all species that might be of concern for the property, it provided a wide range of species that are representative of the wildland habitats in the area. Species occurrence and distribution information is often based on documented occurrences where opportunistic surveys have taken place; therefore, a lack of records does not necessarily indicate that a given species is absent from the Project Site.

3.2 Field Survey

3.2.1 Small Unmanned Aircraft System Survey and Vegetation Mapping

Due to the size of the area and limited road access, ECORP conducted an initial survey utilizing a sUAS to quickly assess current solar field site conditions and gather high-resolution imagery. The drone pilot conducted an initial field reconnaissance upon arrival at the site to obtain an understanding of the site topography, access, vegetation densities, and staging areas for controlling the aerial flights. The drone was programmed to do a systematic flight over the property to collect high-resolution aerial photographs of the entire property. The photos collected were then combined into a single orthomosaic image that was incorporated into mapping files in a Geographic Information System (GIS).

The resulting information gathered from the sUAS/drone survey were then used to assist the biologists with accurate mapping of the vegetation communities. A botanist utilized the high-resolution drone imagery to map vegetation communities. Vegetation classifications were in accordance with *A Manual of California Vegetation* (Sawyer et al. 2009). Vegetation communities that did not fit within the Sawyer classification system were described following Holland (1986) or Cowardin (alternative methods). Areas of the site that had already been graded, developed, and/or disturbed were mapped as such. Acreages of each vegetation community were calculated based on GIS data collected during the sUAS survey.

3.2.2 Biological Reconnaissance Survey

Biologists conducted the biological reconnaissance survey by walking the entire Survey Area to determine the vegetation communities and wildlife habitats present, surveying private property and inaccessible areas within the buffer utilizing binoculars. The biologists documented the plant and animal species present in the Survey Area and assessed the conditions within the Survey Area for their potential to provide habitat for special-status plant and wildlife species, including those from the literature review. Biologists collected the data in the field utilizing ArcGIS™ Field Maps on a device (smartphone or tablet) connected to a Global Positioning System (GPS) unit and on datasheets. ECORP recorded the date, species, notes on location and habitat, behavior (if applicable), and coordinates in instances where a special-status species was observed. Additionally, the biologists recorded locations of incidentally observed sensitive species using ArcGIS™ Field Maps on a GPS-capable device (smartphone or tablet). Biologists took photographs during the survey to provide visual representation of the various vegetation communities within the Survey Area and examined the Survey Area to assess its potential to facilitate wildlife movement or function as a movement corridor for wildlife throughout the region.

Biologists recorded plant and wildlife species, including any special-status species that were observed during the survey. Plant nomenclature follows that of *The Jepson Manual: Vascular Plants of California* (Baldwin et al. 2012). Wildlife nomenclature follows that of *The American Ornithologists' Union (AOU) Checklist of North American Birds (AOU 2022)*, the *Society for the Study of Amphibians and Reptiles (SSAR 2017)*, and the *Revised Checklist of North American Mammals North of Mexico (Bradley et al. 2014)*.

3.2.3 Vegetation Mapping

ECORP used information gathered from the sUAS survey and the biological reconnaissance survey to assist with accurate mapping of the vegetation communities. Biologists conducted vegetation mapping in consideration of Protocols for *Surveying and Evaluating Impacts to Special Status Native Plant Populations and Natural Communities* (CDFW 2018). A botanist utilized the high-resolution drone imagery, as well as performed ground truthing in the field during the biological reconnaissance survey to map vegetation communities. Vegetation classifications were in accordance with *A Manual of California Vegetation* (Sawyer et al. 2009). Sensitive vegetation communities were designated based on the California Sensitive Natural Communities list provided as part of CDFW's Vegetation Classification and Mapping Program (VegCAMP, CDFW 2022e). Photographs taken during the survey provided visual representation of select vegetation communities within the Survey Area. Areas of the site that had already been graded, developed, and/or disturbed were mapped as such. Acreages of each vegetation community were calculated using GIS data collected during the biological reconnaissance survey.

3.2.4 Aquatic Resources Delineation

An aquatic resources delineation was conducted by Hernandez Environmental Services. The results are presented under separate cover.

3.3 Potential for Occurrence Determinations

ECORP used information from the literature review and observations in the field, to generate a list of special-status plant and animal species that have potential to occur within the Survey Area. Biologists assessed special-status species reported for the region in the literature review or for which suitable habitat occurs in the Survey Area for their potential to occur within the Survey Area based on the following guidelines:

- **Present:** The species was observed on site during a site visit or focused survey.
- **High:** Habitat (including soils and elevation factors) for the species occurs within the Survey Area and a known occurrence has recently been recorded (within the last 20 years) within five miles of the area.
- **Moderate:** Habitat (including soils and elevation factors) for the species occurs within the Survey Area and a documented observation occurs within the database search, but not within five miles of the area; a historic documented observation (more than 20 years old) was recorded within five miles of the Survey Area; or a recently documented observation occurs within five miles of the area and marginal or limited amounts of habitat occurs in the Survey Area.
- **Low:** Limited or marginal habitat for the species occurs within the Survey Area and a recently documented observation occurs within the database search, but not within five miles of the area; a historic documented observation (more than 20 years old) was recorded within five miles of the Survey Area; or suitable habitat strongly associated with the species occurs on site, but no records or only historic records were found within the database search.

- **Presumed Absent:** Species was not observed during a site visit or focused surveys conducted in accordance with protocol guidelines at an appropriate time for identification; habitat (including soils and elevation factors) does not exist on site; or the known geographic range of the species does not include the Survey Area.

Note that location information on some special-status species may be of questionable accuracy or unavailable. Therefore, for survey purposes, the environmental factors associated with a species' occurrence requirements may be considered sufficient reason to give a species a positive potential for occurrence. In addition, just because a record of a species does not exist in the databases does not mean it does not occur. In many cases, records may not be present in the databases because an area has not been surveyed for that particular species.

ECORP eliminated plant and wildlife species with a watch list status from the analysis because these rankings are considered a review list.

4.0 RESULTS

The results of the literature review and field surveys, including site characteristics, vegetation communities, wildlife, special-status species, and special-status habitats (including any potential wildlife corridors) are summarized below.

4.1 Literature Review

4.1.1 Special-Status Plants and Wildlife

Special-status plants and wildlife species reported for the region in the literature review or for which suitable habitat occurs were evaluated for their potential to occur within the Survey Area where direct and indirect impacts could occur. Of all available records, ECORP identified a total of 11 special-status plant species and 37 special-status wildlife species as having previously been documented in the vicinity of the Survey Area or having potential to occur within the Survey Area.

4.1.2 U.S. Fish and Wildlife Service Designated Critical Habitat

The Survey Area is not located within any USFWS-designated critical habitat. The nearest critical habitat, for the desert tortoise (*Gopherus agassizii*), is located approximately 8 miles northeast of the Project Site.

4.2 Biological Reconnaissance Survey

ECORP biologists Lauren Simpson and Greg Hampton conducted the biological reconnaissance survey for the Survey Area on October 25 and 26, 2022. The results of the biological reconnaissance survey, including site characteristics, plants and plant communities, wildlife, special-status species, and special-status habitats (including any potential wildlife corridors) are summarized below. Weather conditions during the surveys are summarized in Table 2.

Date	Time		Temperature (°F)		Cloud Cover (%)		Wind Speed (mph)	
	Start	End	Start	End	Start	End	Start	End
10/25/2022	1000	1415	74	79	0	0	0-1	1-4
10/26/2022	0720	1310	55	76	0	0	0-1	0-3

4.2.1 Property Characteristics

The Survey Area consists of undeveloped land that appears to have been historically altered in some areas. Biologists observed not only that some portions of the site, particularly in the northwest corner, appeared to have been previously cleared as well as large stockpiles of vegetation. The clearing activities did not appear recent as several shrubs had regrown in areas that appeared to previously have been cleared. Additionally, some areas along the gen-tie line appeared to recently have been burned. The Survey Area is surrounded to the southwest by agricultural fields, undeveloped land to the northwest, and an aqueduct and transmission lines to the northeast. The site lies between the Coachella Canal to the northeast and East Highline Canal to the southwest. Representative site photographs are included in Appendix A.

Topography throughout the Survey Area is relatively flat. ECORP conducted a soils analysis search using NRCS soil survey data (NRCS 2022a). Four soil series occur within the Survey Area (Figure 3). These include:

- 103- Carsitas gravelly sand, 0 to 5 percent slopes
- 124- Niland gravelly sand
- 125- Niland gravelly sand, wet
- 128- Niland-Imperial complex, wet

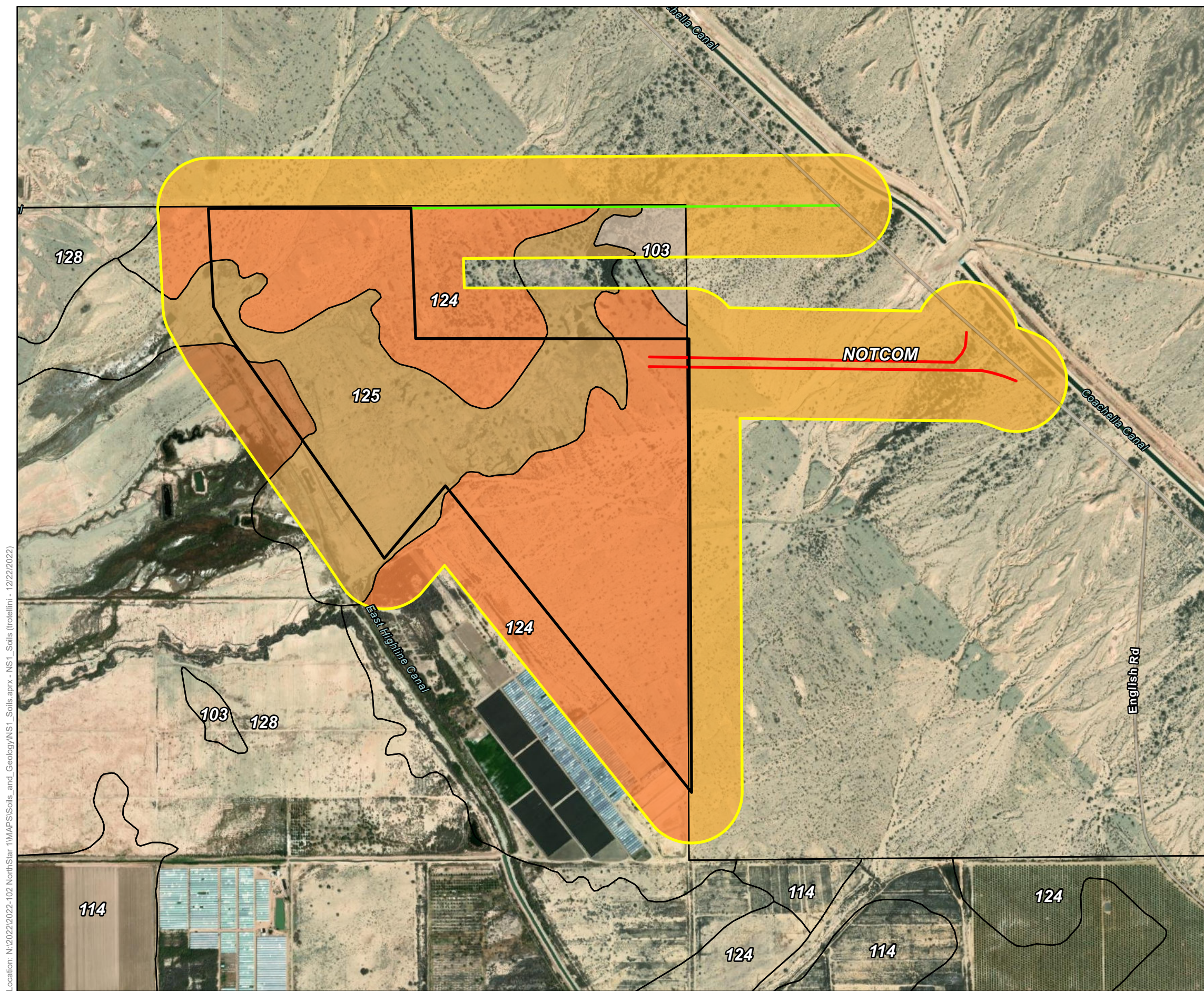

Map Contents

- Project Area
- 500-ft Buffer
- Gen-tie Line
- Loop in/Out IID's N Line

Series Designation - Series Description

- 103 - Carsitas gravelly sand, 0 to 5 percent slopes
- 124 - Niland gravelly sand
- 125 - Niland gravelly sand, wet
- 128 - Niland-Imperial complex, wet
- NOTCOM - No Digital Data Available

Service Layer Credits: Cherted Territory: California State Parks, Esri, HERE, Garmin, SafeGraph, METI/ NASA, USGS, Bureau of Land Management, EPA, NPS, USDA
 Hybrid Reference Layer: Esri Community Maps Contributors, California State Parks, Esri, HERE, Garmin, SafeGraph, GeoTechnologies, Inc, METI/NASA, USGS, Bureau of Land Management, EPA, NPS, US Census Bureau, USDA
 World Imagery: Maxar
 World Hillshade: Esri, NASA, NGA, USGS



Location: N:\2022\2022-102 NorthStar 1\MAPS\Soils_and_Geology\NS1_Soils.aprx - NS1_Soils (truelini) - 12/22/2022

Map Date: 12/22/2022

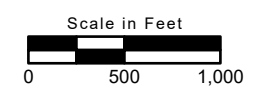
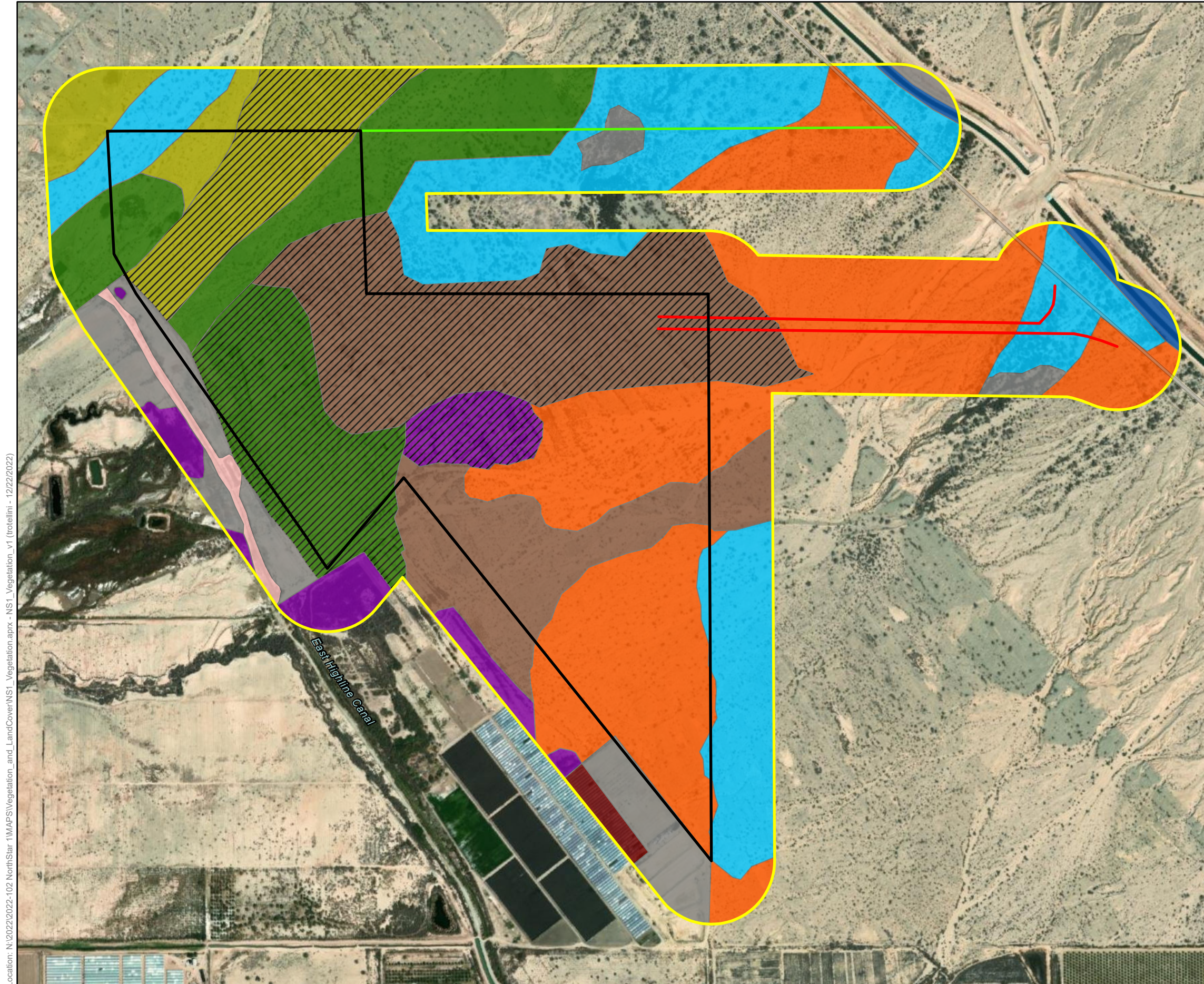

Figure 3. Natural Resources Conservation Service Soil Types
 2022-102 North Star 1 Project

4.2.2 Vegetation Communities/Land Use

The majority of the Project Site consists of creosote bush scrub and disturbed-fourwing saltbush scrub. The location of each vegetation community in the Project Site and Survey Area are described in detail below and presented on Figure 4. Acreages of each habitat and vegetation community in the Survey Area (including the buffer area) are shown in Table 3. Representative photographs of the habitats within the Survey Area are included in Appendix A. A full list of plant species observed during the reconnaissance survey is provided in Appendix D.

Table 3. Vegetation Communities and Land Cover Types in Survey Area		
Vegetation Communities and Land Cover Types	Acres in Project Site	Acres in 500-foot buffer
Creosote Bush Scrub (<i>Larrea tridentata</i> Shrubland Alliance)	77.43	101.53
Iodine Bush Scrub (<i>Allenrolfea occidentalis</i> Shrubland Alliance)	21.70	37.12
Disturbed – Iodine Bush Scrub (Disturbed <i>Allenrolfea occidentalis</i> Shrubland Alliance)	40.56	8.35
Blue Palo Verde – Ironwood Woodland (<i>Parkinsonia florida</i> - <i>Olneya tesota</i> Woodland Alliance)	5.44	120.00
Bush Seepweed Scrub (<i>Suaeda moquinii</i> Shrubland Alliance)	5.14	13.24
Disturbed – Bush Seepweed Scrub (Disturbed <i>Suaeda moquinii</i> Shrubland Alliance)	22.80	12.82
Tamarisk Thicket (<i>Tamarix</i> spp. Semi-natural Shrubland Stands)	-	16.92
Disturbed- Tamarisk Thickets (Disturbed – <i>Tamarix</i> spp. Semi-natural Shrubland Stands)	12.35	-
Arrow weed Thickets (<i>Pluchea sericea</i> Shrubland Alliance)	-	5.21
Fourwing Saltbush Scrub (<i>Atriplex canescens</i> Shrubland Alliance)	28.92	21.70
Disturbed – Fourwing Saltbush Scrub (Disturbed – <i>Atriplex canescens</i> Shrubland Alliance)	69.44	28.96
Disturbed	1.96	40.17
Active Agriculture	-	-3.43
Aqueduct	-	-5.26
Area Totals	285.74	397.33



Map Contents

- Project Area
- 500-ft Buffer
- Gen-tie Line
- Loop in/Out IID's N Line

Vegetation Communities and Land Cover Types

- Creosote Bush Scrub (*Larrea tridentata* Shrubland Alliance)
- Iodine Bush Scrub (*Allenrolfea occidentalis* Shrubland Alliance)
- Disturbed - Iodine Bush Scrub (Disturbed - *Allenrolfea occidentalis* Shrubland Alliance)
- Blue Palo Verde – Ironwood Woodland (*Parkinsonia florida*-*Olneya tesota* Woodland Alliance)
- Bush Seepweed Scrub (*Suaeda moquinii* Shrubland Alliance)
- Disturbed - Bush Seepweed Scrub (Disturbed - *Suaeda moquinii* Shrubland Alliance)
- Tamarisk Thicket (*Tamarix* spp. Semi-natural Shrubland Stands)
- Disturbed - Tamarisk Thickets (Disturbed - *Tamarix* spp. Semi-natural Shrubland Stands)
- Arrowweed Thickets (*Pluchea sericea* Shrubland Alliance)
- Fourwing Saltbush Scrub (*Atriplex canescens* Shrubland Alliance)
- Disturbed-Fourwing Saltbush Scrub (Disturbed - *Atriplex canescens* Shrubland Alliance)
- Disturbed
- Active Agriculture
- Aqueduct

Service Layer Credits: Charted Territory; California State Parks, Esri, HERE, Garmin, SafeGraph, METI/ NASA, USGS, Bureau of Land Management, EPA, NPS, USDA
 Hybrid Reference Layer: Esri Community Maps Contributors; California State Parks, Esri, HERE, Garmin, SafeGraph, GeoTechnologies, Inc., METI/NASA, USGS, Bureau of Land Management, EPA, NPS, US Census Bureau, USDA
 World Imagery: Maxar
 World Hillshade: Esri, NASA, NGA, USGS



Location: N:\2022\2022-102 NorthStar 1\MAPS\Vegetation_and_LandCover\NS1_Vegetation.aprx - NS1_Vegetation_v1 (trotellini - 12/22/2022)

Figure 4. Vegetation Communities and Land Cover Types

4.2.2.1 Vegetation Communities within the Project Site

Biologists observed nine vegetation communities (including their disturbed counterparts) and one land cover within the Project Site. These vegetation communities and land covers are described in detail below.

Creosote Bush Scrub (*Larrea tridentata* Shrubland Alliance)

Creosote bush scrub is the most characteristic vegetation of the California desert and is found on alluvial fans, bajadas, upland slopes, and washes. Creosote bush scrub is dominated by a nearly monotypic stand of creosote bush (*Larrea tridentata*) with an open canopy and an herbaceous layer of seasonal annuals and perennials. Other species that occurred on the Project Site included white bursage (*Ambrosia dumosa*), cheese bush (*Ambrosia salsola*), and honeysweet (*Tidestromia suffruticosa*). Creosote bush scrub has a global and state rarity rank of G5 and S5, respectively, and is not considered a sensitive community (VegCAMP, CDFW 2022e).

Iodine Bush Scrub (*Allenrolfea occidentalis* Shrubland Alliance)

Iodine bush scrub is found on playas perched above drainages, seep, and dry lakebed margins. Iodine bush, a USFWS Wetland Inventory FACW+ species (USACE 1996), is dominant in the shrub and herbaceous layers in an open to continuous canopy. Other plant species observed within this community include four-wing saltbush (*Atriplex canescens*), tamarisk (*Tamarix* spp.), and bush seepweed (*Suaeda moquinii*). Iodine bush scrub has a global and state rarity rank of G4 and S3, respectively, and is considered a sensitive community (VegCAMP, CDFW 2022e).

Disturbed- Iodine Bush Scrub (Disturbed- *Allenrolfea occidentalis* Shrubland Alliance)

Disturbed- iodine bush scrub is iodine bush scrub that has been previously altered. Iodine bush is dominant in the shrub canopy with an absent herbaceous layer. On the Project Site, this vegetation cover is characterized as sparser with a high percentage of anthropogenic disturbances such as grading, tire tracks, and trash.

Blue Palo Verde – Ironwood Woodland (*Parkinsonia florida* – *Olneya tesota* Woodland Alliance)

Blue palo verde – ironwood woodland is found on desert arroyo margins, bottomlands, middle and upper bajadas, alluvial fans, washes, and lower slopes. Blue palo verde – ironwood woodland is dominated by blue palo verde (*Parkinsonia florida*) and/or ironwood (*Olneya tesota*) in the tree canopy, with associate species such as desert willow (*Chilopsis linearis*), sweetbush (*Bebbia juncea*), and brittlebush (*Encelia farinosa*). This vegetation community typically has a sparse to intermittent herbaceous layer. On the Project Site, ironwood dominated the tree canopy with occasional occurrences of blue palo verde, and tamarisk (*Tamarix* sp.). Blue palo verde – ironwood woodland (*Olneya tesota* association) has a global and state rarity rank of G4 and S4, respectively, and is considered a sensitive community by CDFW (VegCAMP, CDFW 2022e).

Bush Seepweed Scrub (*Suaeda [moquinii] nigra* Shrubland Alliance)

Bush seepweed scrub is found on flat to gently sloping valley bottoms, bajadas, and toe slopes adjacent to alluvial fans. Bush seepweed scrub is dominated by bush seepweed, a USFWS Wetland Inventory OBL species (USACE 1996) and can be co-dominant with four-wing saltbush and/or alkali goldenbush (*Isocoma acradenia*). This vegetation community typically has a sparse to intermittent herbaceous layer. On the Project Site, bush seepweed scrub dominated the shrub cover with occasional occurrences of four-wing saltbush, arrow weed, and tamarisk. Bush seepweed scrub has a global and state rarity rank of G4 and S3, respectively, and is considered a sensitive community (VegCAMP, CDFW 2022e).

Disturbed Bush seepweed Scrub (Disturbed *Suaeda [moquinii] nigra* Shrubland Alliance)

Disturbed bush seepweed scrub is bush seepweed scrub that has been previously altered. Seepweed is dominant in the shrub canopy with an absent to sparse herbaceous layer. On the Project Site, this vegetation cover is characterized as sparser with a high percentage of anthropogenic disturbances such as grading, tire tracks, and trash.

Disturbed Tamarisk Thickets (Disturbed *Tamarix* spp. Shrubland Semi-Natural Alliance)

Disturbed tamarisk thickets are tamarisk thickets that have been previously altered. Tamarisk is dominant in the shrub canopy with an absent herbaceous layer. On the Project Site, this vegetation cover is characterized as sparser with a high percentage of anthropogenic disturbances such as grading, tire tracks, and trash. Disturbed tamarisk thickets is a nonnative vegetation community that is not globally or state ranked.

Fourwing Saltbush Scrub (*Atriplex canescens* Shrubland Alliance)

Fourwing saltbush scrub is found on playas, old beach and shores, lake deposits, alluvial fans, and rolling hills. Fourwing saltbush scrub is dominated by fourwing saltbush and can be co-dominant with white bursage, cheesebush, and/or cattle spinach (*Atriplex polycarpa*). This vegetation community typically has a variable, seasonal herbaceous layer with nonnative grasses. On the Project Site, fourwing saltbush dominated the shrub cover with occasional occurrences of creosote bush, cheesebush, white bursage, goldenbush, and tamarisk. Fourwing saltbush scrub has a global and state rarity rank of G5 and S4, respectively, and is not considered a sensitive community (VegCAMP, CDFW 2022e).

Disturbed Fourwing Saltbush Scrub (Disturbed *Suaeda [moquinii] nigra* Shrubland Alliance)

Disturbed fourwing saltbush scrub is fourwing saltbush scrub that has been previously altered. Fourwing saltbush is dominant in the shrub canopy with an absent to sparse herbaceous layer. On the Project Site, this vegetation cover is characterized as sparser with a high percentage of anthropogenic disturbances such as grading, tire tracks, and trash.

4.2.2.2 Other Land Cover Types within the Project Site

Disturbed

The disturbed land cover type includes areas where the native vegetation community has been heavily influenced by human actions, such as grading, trash dumping, and Off-Highway Vehicle use, but lack development. Disturbed land is not a vegetation classification, but rather a land cover type and is not restricted by elevation. On the Project Site, the areas consisted primarily of bare ground. In some areas, disturbed land included areas that had recently been severely burned.

4.2.2.3 Vegetation Communities within the Survey Area

In addition to all the vegetation communities present within the Project Site, two vegetation communities and two land cover types were observed within the survey buffer, but not within the Project Site. These vegetation communities and land covers are described in detail below. No direct impacts to these vegetation communities and land covers are expected as a result of Project-related activities.

4.2.2.4 Arrow Weed Thickets (*Pluchea sericea* Shrubland Alliance)

Arrow weed thickets are associated with moderate to dense scrub primarily dominated by arrow weed (*Pluchea sericea*). Other species that occur as scattered individuals include tamarisk, willow baccharis (*Baccharis salicina*), and big saltbush (*Atriplex lentiformis*). This vegetation community appears around springs, seeps, irrigation ditches, canyon bottoms, seasonally flooded washed, stream banks, and within stream beds and ditches. In the Survey Area, this vegetation cover is characterized as sparser. Other plant species observed included narrowleaf cattail (*Typha domingensis*) and tamarisk. Arrow weed thickets have a global and state rarity rank of G4 and S3 respectively and is considered a sensitive community (VegCAMP, CDFW 2022e).

4.2.2.5 Tamarisk Thicket (*Tamarix* spp. Shrubland Semi-Natural Alliance)

Tamarisk thickets are characterized by a weedy monoculture of tamarisk. This habitat is typically in ditches, washes, rivers, arroyo margins, lake margins, and other watercourses. Within the Survey Area, tamarisk and arrow weed were often co-dominant in this vegetation community. Other plant species observed included cattails (*Typha* spp.), arrow weed, and willow baccharis. A global and state rarity rank is not applicable to tamarisk thickets (VegCAMP, CDFW 2022e).

4.2.3 Other Land Cover Types within the Survey Area

4.2.3.1 Active Agriculture

Active agriculture includes planted, typically monotypic rows of crops of annual and perennial species with open space between rows. It is not a vegetation classification, but rather a land cover type and is not restricted by elevation. Species composition frequently changes by season and year. Active agriculture often occurs in upland areas with high soil quality, or floodplains and are almost always artificially irrigated. This land cover was observed in the southwestern buffer areas.

4.2.3.2 Aqueduct

Aqueduct includes areas where an artificial concrete channel is conveying water. No plant species or communities were observed within the aqueduct during the survey effort. It is not a vegetation classification, but rather a land cover type and is not restricted by elevation. This land use was observed in the northeastern buffer areas.

4.2.4 Wildlife Observed

Wildlife species observed included zebra-tailed lizard (*Callisaurus draconoides*), side-blotched lizard (*Uta stansburiana*), black-tailed gnatcatcher (*Polioptila melanura*), American kestrel (*Falco sparverius*), red-tailed hawk (*Buteo jamaicensis*), northern flicker (*Colaptes auratus*), Abert's towhee (*Melospiza aberti*), killdeer (*Charadrius vociferus*), rock wren (*Salpinctes obsoletus*), verdin (*Auriparus flaviceps*), great-tailed grackle (*Quiscalus mexicanus*), Say's phoebe (*Sayornis saya*), white-crowned sparrow (*Zonotrichia leucophrys*), great blue heron (*Ardea herodias*), common raven (*Corvus corax*), desert cottontail (*Sylvilagus audubonii*), antelope ground squirrel (*Ammospermophilus leucurus*), and bat sign (Order Chiroptera)(guano). A full list of wildlife species observed is provided in Appendix E.

ECORP observed an abandoned building during the biological reconnaissance survey in the northwest corner of the Project Site. Biologists observed suitable habitat for roosting bats within this building, as well as evidence of extensive previous use by roosting bats (e.g., guano, staining), indicating that the building may be a maternity colony roosting site.

ECORP observed no live bats during the survey and did not conduct a focused bat survey because the reconnaissance survey was conducted outside of the bat maternity season. There is a small outhouse adjacent to the abandoned building that had trace amounts of bat sign. Focused bat surveys during the appropriate season (spring and summer) would be required to determine what species may be using these structures and for what purpose.

4.3 Special-Status Species Assessment

The literature review resulted in eight special-status plant and 37 special-status wildlife species that have recently and historically been recorded in the vicinity of the Project Site or that are highly associated with habitat that occurs within the Survey Area. Special-status plants were evaluated for their potential to occur within the Project Site where direct impacts could occur. ECORP evaluated special-status wildlife for their potential to occur within the Survey Area, a broader area that includes the Project Site and buffer, where direct or indirect impacts could occur. Special-status wildlife species observed during the reconnaissance survey are depicted on Figure 5.

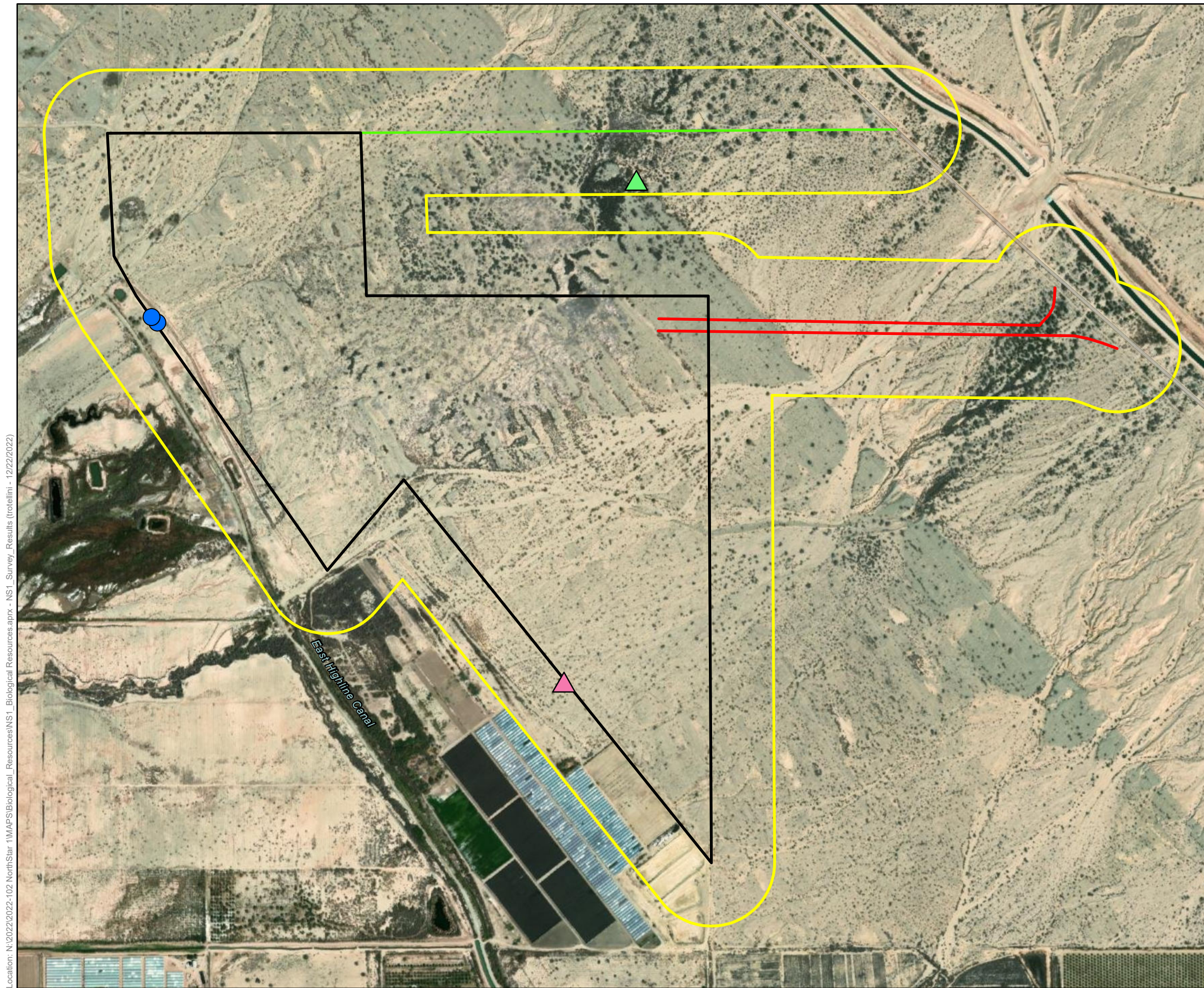

Map Contents

- Project Area
- 500-ft Buffer
- Gen-tie Line
- Loop in/Out IID's N Line

Survey Results

- Loggerhead Shrike
- Long-eared Owl
- Bat Roost

Service Layer Credits: Charted Territory, California State Parks, Esri, HERE, Garmin, SafeGraph, METI/ NASA, USGS, Bureau of Land Management, EPA, NPS, USDA
 Hybrid Reference Layer: Esri Community Maps Contributors, California State Parks, Esri, HERE, Garmin, SafeGraph, GeoTechnologies, Inc., METI/NASA, USGS, Bureau of Land Management, EPA, NPS, US Census Bureau, USDA
 World Imagery: Maxar
 World Hillshade: Esri, NASA, NGA, USGS



Location: N:\2022\2022-102 NorthStar_1\MAPS\Biological_Resources\NS1_Survey_Results (trtelini - 12/22/2022)

Map Date: 12/22/2022

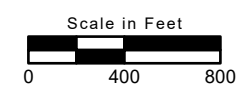

Figure 5. Special-status Species Survey Results

4.3.1 Plants

Numerous special-status plant species have been recorded within 5 miles of the Project Site, according to the CNDDDB (CDFW 2022a), Information for Planning and Consultation (USFWS 2022b), and CNPSEI (CNPS 2022). Of all available records, biologists identified a total of eight species as those with the potential for occurrence within the vicinity of the Project Site. Table 4 provides descriptions of the CNPS designations; a list of the special-status plant species identified in the literature review is presented following Table 4.

Table 4. California Native Plant Society Status Designations	
List Designation	Meaning
1A	Plants Presumed Extirpated in California and Either Rare or Extinct Elsewhere
1B	Plants Rare, Threatened, or Endangered in California and Elsewhere
2A	Plants Presumed Extirpated in California, But Common Elsewhere
2B	Plants Rare, Threatened, or Endangered in California, But More Common Elsewhere
3	Plants about which we need more information; a review list
4	Plants of limited distribution; a watch list
List 1B, 2, and 4 extension meanings:	
.1	Seriously threatened in California (over 80 percent of occurrences threatened/high degree and immediacy of threat)
.2	Moderately threatened in California (20-80 percent occurrences threatened/moderate degree and immediacy of threat)
.3	Not very threatened in California (less than 20 percent of occurrences threatened/low degree and immediacy of threat or no current threats known)

Note: According to CNPS (Skinner and Pavlik 1994), plants on Lists 1B and 2 meet definitions for listing as threatened or endangered under Section 1901, Chapter 10 of the California Fish and Game Code (California Department of Fish and Game [CDFG] 1984). This interpretation is inconsistent with other definitions.

4.3.1.1 *Plant Species with a High Potential to Occur*

The following species were determined to have a high potential to occur due to the presence of suitable habitat and several known recent occurrences within 5 miles of the Project Site:

- Harwood's milk-vetch (*Astragalus insularis* var. *harwoodii*) is a CRPR 2B.2 plant species. This species is known to occur at elevations between sea level and 2,330 feet amsl and blooms between January and May. Harwood's milk-vetch is known to occur in Mojavean desert scrub and desert dunes within sometimes gravelly or sandy soils. One recent (2005) CNDDDB record was located less than 1 mile east of the Project Site near the Gas Line Road. There is potential habitat within the Project Site for this species in the creosote bush scrub habitats.

- Munz's cholla (*Cylindropuntia munzii*) is a CRPR 1B.3 plant species. This species is known to occur at elevations between 490 and 1,970 feet amsl and blooms in May. Munz's cholla is known to occur in Sonoran desert scrub within gravelly or sandy soils. Recent (2017) There are CNDDDB record observations approximately 5 miles east of the Project Site in large portions of the Chocolate Mountain Aerial Gunnery Range. There is potential habitat within the Project Site for this species in the creosote bush scrub habitats.

4.3.1.2 Plant Species with a Moderate Potential to Occur

The following species was determined to have a moderate potential to occur due to the presence of suitable habitat and several known occurrences within 5 miles of the Project Site:

- Orocopia sage (*Salvia greatae*) is a CRPR 1B.3 plant species. This species is known to occur at elevations between -130 and 2,705 feet amsl and blooms between March and April. Orocopia sage is known to occur in Mojavean and Sonoran desert scrub habitat. One historic (1990) CNDDDB record was located approximately 5 miles northwest of the Project Site near the Siphon Seventeen. There is potential habitat within the Project Site for this species in the creosote bush scrub habitats.

4.3.1.3 Plant Species with Low Potential to Occur

The following species were found to have a low potential to occur within the Project Site because of limited habitat for the species on the site and a known occurrence has been reported in the database, but not within 5 miles of the Project Site, or suitable habitat strongly associated with the species occurs within the Project Site, but no records were found in the database search:

- Gravel milk-vetch (*Astragalus sabulonum*), CRPR 2B.2
- Sand evening-primrose (*Chylismia arenaria*), CRPR 2B.2
- Las Animas colubrina (*Colubrina californica*), CRPR 2B.3
- Glandular ditaxis (*Ditaxis claryana*), state-listed endangered, CRPR 1B.2
- Narrow-leaf sandpaper-plant (*Petalonyx linearis*), CRPR 2B.3

4.3.2 Wildlife

The literature search documented 37 special-status wildlife species in the vicinity of the Project Site or with habitat within the Survey Area, 10 of which are federally and/or state-listed. Of the 37 special-status wildlife species identified in the literature review, two were present within the Project Site, four were found to have a high potential to occur, six were found to have a moderate potential to occur, and 10 were found to have a low potential to occur; the remaining 15 species are presumed absent from the Project Site. Descriptions of the federal and state wildlife designations are found in Table 5, and a brief natural history and discussion of the special-status wildlife species found onsite that have a high or moderate potential to occur within the Project Site are provided below.

Table 5. Wildlife Status Designations	
List Designation	Meaning
Federal Designation	Jurisdiction under United States Fish and Wildlife Service (USFWS)
END	Federally listed as Endangered
THR	Federally listed as Threatened
CAN	Federal Candidate Species
FSC	Federal Species of Concern
DL	Federal Delisted
State Designation	Jurisdiction under California Fish and Wildlife Service (CDFW)
END	State listed as Endangered
THR	State listed as Threatened
SSC	California Species of Special Concern
FP	Fully Protected Species
DL	State Delisted
BLM Designation	Jurisdiction under Bureau of Land Management
S	Sensitive

4.3.2.1 Special-Status Wildlife Species Present

The following species were observed on the site during the reconnaissance survey:

- Loggerhead shrike is a CDFW SSC. This species prefers open country with scattered shrubs and trees. They frequent agricultural fields, abandoned orchards, desert scrublands, and riparian areas. One individual was observed perching in the creosote bush scrub in the southwestern section of the Survey Area during the 2022 biological reconnaissance survey (Figure 5).
- Long-eared owl is a CDFW SSC. This species prefers areas with dense trees for nesting and/or roosting adjacent to open areas for hunting. Long-eared owls are found in a variety of woodland habitats including forests adjacent to meadows and streamside desert groves. A pair of long-eared owls were observed in the Survey Area along the northern gen-tie in the blue palo verde - ironwood woodland community during the 2022 biological reconnaissance survey (Figure 5).

4.3.2.2 Special-Status Wildlife Species with a High Potential to Occur

Four species were found to have high potential to occur within the Survey Area due to the presence of highly suitable habitat for the species on the site and/or because a known occurrence has been recorded within five miles of the site:

- Burrowing owl (*Athene cunicularia*) is a CDFW SSC, BLM Sensitive species, and Imperial County species of conservation focus. It is typically found in dry open areas with few trees and short grasses; it is also found in vacant lots near human habitation. It uses uninhabited mammal burrows for roosts and nests, often in close proximity to California ground squirrel colonies. Highly suitable habitat for burrowing owl is present throughout most of the Survey Area. Additionally, numerous occurrences of burrowing owl within five miles of the Survey Area have been documented in the CNDDB.
- Pallid bat (*Antrozous pallidus*) is a CDFW SSC and BLM Sensitive species. This species is commonly found in desert habitats and is known to roost in anthropogenic structures such as buildings. Roosting habitat for this species is present within the abandoned building located in the northwest corner of the Project Site. Bat sign (guano and urine staining) was observed inside the building as well as evidence of previous roosting by pallid bat (large, culled insect parts and moth wings among the other bat sign present).
- Yuma myotis (*Myotis yumanensis*) is a BLM Sensitive species. This species is found in desert scrub and woodland habitats near water and commonly forms maternity roosts in anthropogenic structures such as buildings. Roosting habitat for this species is present within the abandoned building located in the northwest corner of the Project Site. Bat sign (guano and staining) was observed inside the building.
- Desert kit fox (*Vulpes macrotis arsipus*) is a fur-bearing mammal that is protected under the California Code of Regulations Title 14, Chapter 5, Section 460 which prohibits take of the species at any time. Therefore, CDFW does not have a mechanism for take of the species by development projects. The desert kit fox is found in desert habitats that include vegetation communities in the Survey Area such as creosote bush scrub. Suitable habitat for desert kit fox is present throughout most of the Survey Area and burrows that may have been dug by desert kit fox were observed during the reconnaissance survey.

4.3.2.3 Special-Status Wildlife Species with a Moderate Potential to Occur

Six species were found to have moderate potential to occur within the Project Site because habitat for the species occurs on the site and a known occurrence exists within the database search, but not within five miles of the site; or a known occurrence exists within five miles of the site and marginal or limited amounts of habitat occurs within the Project Site:

- Couch's spadefoot (*Scaphiopus couchii*) is a CDFW SSC. This species is found underground in arid and desert regions of creosote bush scrub and sandy washes and surfaces during rain

events. There is suitable habitat for this species within the creosote bush scrub and other desert scrub habitats onsite.

- Flat-tailed horned lizard (*Phrynosoma mcallii*) is a CDFW SSC, BLM Sensitive species, and Imperial County Species of conservation focus. This species is most commonly found on sandy flats and valleys within desert scrub habitats with little or no windblown sand. They can also be found on salt flats and gravelly soils. The creosote bush scrub and sandy wash habitats in the Project Site provides suitable habitat for the flat-tailed horned lizard.
- Townsend's big-eared bat (*Corynorhinus townsendii*) is a CDFW SSC. The Project Site is within the known range of this species and this species is known to roost in buildings. Potential roosting habitat for this species is present within the abandoned building present in the northwest corner of the Project Site.
- Small-footed myotis (*Myotis ciliolabrum*) is a BLM Sensitive species. The Project Site is within the known range of this species and this species is known to sometimes roost in buildings. Potential roosting habitat for this species is present within the abandoned building present in the northwest corner of the Project Site.
- Fringed myotis (*Myotis thysanodes*) is a BLM Sensitive species. The Project Site is within the known range of this species and this species is known to sometimes roost in buildings. Potential roosting habitat for this species is present within the abandoned building present in the northwest corner of the Project Site.
- American badger (*Taxidea taxus*) is a CDFW SSC. American badgers are found in a wide variety of open habitats with friable soils including desert scrub and woodland habitats. Suitable habitat for this species is present throughout the Survey Area.

4.3.2.4 Wildlife Species with Low Potential to Occur

Ten species were found to have a low potential to occur within the Project Site because limited habitat for the species occurs on the site and a known occurrence has been reported in the database, but not within five miles of the site, or suitable habitat strongly associated with the species occurs on the site, but no records were found in the database search:

- desert tortoise, federally listed threatened, and state listed threatened,
- southwestern willow flycatcher (*Empidonax traillii* ssp. *extimus*), federally listed endangered and state-listed endangered,
- Yellow-breasted chat (*Icteria virens*), CDFW SSC,
- California black rail (*Laterallus jamaicensis coturniculus*), state-listed threatened, CDFW Fully Protected, BLM Sensitive
- Gila woodpecker (*Melanerpes uropygialis*), state-listed endangered, BLM Sensitive

- Yuma Ridgway's rail (*Rallus obsoletus* ssp. *yumanensis*), federally-listed endangered, state-listed threatened, CDFW Fully Protected
- yellow warbler (*Setophaga petechia*), CDFW SSC,
- Crissal thrasher (*Toxostoma crissale*), CDFW SSC, BLM Sensitive,
- Long-eared myotis (*Myotis evotis*), BLM Sensitive, and
- Yuma hispid cotton rat (*Sigmodon hispidus eremicus*) CDFW SSC.

4.3.2.5 Wildlife Species Presumed Absent

The following 15 species are presumed absent from the Project Site due to the lack of suitable habitat on the site:

- desert pupfish (*Cyprinodon macularius*), federally listed endangered and state-listed endangered,
- razorback sucker (*Xyrauchen texanus*), federally listed endangered and state-listed endangered,
- Sonoran Desert toad (*Incilius alvarius*), CDFW SSC,
- lowland leopard frog (*Lithobates yavapaiensis*), CDFW SSC, BLM Sensitive,
- western snowy plover (*Charadrius nivosus nivosus*), federally listed threatened, CDFW SSC,
- mountain plover (*Charadrius montanus*), CDFW SSC, BLM Sensitive,
- western yellow-billed cuckoo (*Coccyzus americanus occidentalis*), federally listed threatened and state-listed endangered,
- gull-billed tern (*Gelochelidon nilotica*), CDFW SSC,
- California brown pelican (*Pelecanus occidentalis californicus*), federally- and state-delisted, BLM Sensitive,
- black skimmer (*Rynchops niger*), CDFW SSC,
- least Bell's vireo (*Vireo bellii pusillus*), federally- and state-listed endangered,
- western mastiff bat (*Eumops perotis* ssp. *californicus*), CDFW SSC,
- Western yellow bat (*Lasiurus xanthinus*), CDFW SSC,
- pocketed free-tailed bat (*Nyctinomops femorosaccus*), CDFW SSC, and
- desert bighorn sheep (*Ovis canadensis nelsoni*), CDFW Fully Protected, BLM Sensitive.

4.4 Jurisdictional Aquatic Resources Assessment

An aquatic resources delineation was conducted by Hernandez Environmental Services. The results are presented under separate cover.

4.5 Wildlife Movement Corridors, Linkages, and Significant Ecological Areas

The concept of habitat corridors addresses the linkage between large blocks of habitat that allow the safe movement of mammals and other wildlife species from one habitat area to another. The definition of a corridor is varied, but corridors may include such areas as greenbelts, refuge systems, underpasses, and biogeographic land bridges, for example. In general, a corridor is described as a linear habitat, embedded in a dissimilar matrix, which connects two or more large blocks of habitat. Wildlife movement corridors are critical for the survivorship of ecological systems for several reasons. Corridors can connect water, food, and cover sources, spatially linking these three resources with wildlife in different areas. In addition, wildlife movement between habitat areas provides for the potential of genetic exchange between wildlife species populations, thereby maintaining genetic variability and adaptability to maximize the success of wildlife responses to changing environmental conditions. This is especially critical for small populations subject to loss of variability from genetic drift and effects of inbreeding. Naturally, the nature of corridor use and wildlife movement patterns varies greatly among species.

The Survey Area was assessed for its ability to function as a wildlife corridor. A review of the Terrestrial Connectivity, Areas of Conservation Emphasis (ACE) in the BIOS viewer determined that the Survey Area is primarily located in areas ranked as "Large Natural Habitat Areas" (Rank 2) with areas to the north and south of the Survey Area ranked as "Connections with Implementation Flexibility" (Rank 3, CDFW 2022a). The Large Natural Habitat Areas ranking includes areas that have large blocks of habitat where connectivity is generally intact. The Connections with Implementation Flexibility ranking includes areas that have been identified as having connectivity importance but are not channelized areas, species corridors, or habitat linkages.

The Survey Area is a generally open and undeveloped space with wash habitats that provide cover for migrating and nesting birds. It also provides foraging habitat for raptors and small and large mammals, including rodents and canids. The desert washes located throughout the Project Site are likely utilized by wildlife moving through the area and these features and associated habitats may be considered linkages between conserved natural habitat areas or important areas for wildlife movement because of the nearby direct connectivity to open spaces to the north, northwest, and southeast. The northeast and southwest boundaries are restricted by the Coachella Canal to the northeast and agricultural areas to the southwest. As such, the Survey Area may serve as an area for movement opportunities of local wildlife including nesting and migratory birds and small mammals but would not be considered a wildlife movement corridor that would need to be preserved to allow wildlife to move between important natural habitat areas.

5.0 PROJECT IMPACTS

Implementation of the Project has potential to impact creosote bush scrub, iodine bush scrub, disturbed-iodine bush scrub, blue palo verde – ironwood woodland, bush seepweed scrub, disturbed-bush seepweed scrub, disturbed-tamarisk thickets, fourwing saltbush scrub, and disturbed-fourwing saltbush scrub. These communities may provide suitable raptor foraging habitat, nesting and foraging habitat for passerines and other bird species including burrowing owl and loggerhead shrike, habitat for special-status amphibian and reptile species, habitat for special-status mammal species including American badger and desert kit fox, and rare plant habitat. Additionally, an abandoned building and associated outhouse structure located on the Project Site was identified as a bat roosting site that may provide roosting habitat for special-status bat species and maternity roosts.

Conceptual design of the Project has not been finalized; therefore, impacts and minimization measures cannot be confirmed at this time. The following recommendations would be required to determine if the Project would result in significant impacts to vegetation communities, special-status plant and wildlife species, jurisdictional waters, and wildlife movement corridors.

5.1.1 Special-Status Species

5.1.1.1 Special-Status Plants

The literature review identified 8 special-status plant species that have the potential to occur within the Project Site. However, 5 of these plant species have a low potential to occur due to distance from the Project Site being greater than five miles. These species include gravel milk-vetch, sand evening-primrose, Las Animas colubrina, glandular ditaxis, and narrow-leaf sandpaper-plant.

There is moderate potential for one rare plant species, Orocopia sage (CRPR 1B.3), and high potential for two rare plant species, Harwood's milk-vetch (CRPR 2B.2) and Munz's cholla (1B.3), to be present within the Project Site. Suitable habitat for these species is present within the creosote bush scrub habitats. Impacts that may occur to the species include loss of individuals, habitat, and seedbank. Depending on the size of the population, this impact may be significant. Implementation of BIO-1 and BIO-2 is recommended to reduce impacts to a less than significant level.

5.1.1.2 Special-Status Wildlife

The literature review identified 37 special-status wildlife species that have potential to occur within the vicinity of the Survey Area or have the potential to occur within the Project Site. However, 25 of these species have a low or no potential to occur due to the lack of suitable habitat, limited habitat within the Project Site, and/or the Project occurs outside the known range of these species. Construction of the Project will not contribute to the overall decline of any of these species and no impacts to these species are anticipated to result from this Project.

Two special-status wildlife species (CDFW SSC species) were observed on site during the habitat assessment: loggerhead shrike and long-eared owl. An additional four species were determined to have a high potential to occur: burrowing owl, pallid bat, Yuma myotis, and desert kit fox and six species were

determined to have a moderate potential to occur: Couch's spadefoot, flat-tailed horned lizard, Townsend's big-eared bat, small-footed myotis, fringed myotis, and American badger. Direct impacts to these species that could occur include injury, mortality, nest or maternity colony failures, and loss of young. Indirect impacts include loss of nesting, roosting, and foraging habitat, and increase in anthropogenic effects (i.e., noise levels, introduction of invasive/nonnative species, increase in human activity, increase in dust). Impacts to these species could be considered significant; therefore, implementation of BIO-2, BIO-3, BIO-4, and BIO-5 is recommended.

There is foraging habitat for a number of raptor species and breeding habitat for numerous passerine species that are protected by the MBTA throughout the Project Site. The site provides nesting habitat for ground-nesting species as well as species that nest in desert scrub and woodland habitats. Direct impacts to nesting avian species include injury, mortality, loss of young, and nest failure. Indirect impacts include loss of foraging and nesting habitat for passerine and raptors species, increase in noise and human activities, and potential introduction of invasive/nonnative species. Implementation of BIO-2, BIO-3, and BIO-4 are recommended to mitigate for potential impacts.

ECORP documented a previously occupied bat roost site in an abandoned building and adjacent outhouse structure in the northwest corner of the Project Site. The evidence of bat use indicated that this building may be a site used by bat maternity colonies. Further, this building provides suitable habitat for CDFW SSC bat species and BLM Sensitive bat species. Bat species in California are protected by Section 4150 (protection of non-game mammals from take) of the California Fish and Game Code. Section 4150 of the California Fish and Game Code prohibits the take of any naturally occurring mammals in California that are nongame mammals, which includes all species of the Order Chiroptera (bats). Further, bat maternity roosting habitats are protected as native wildlife nursery sites under CEQA. The reconnaissance survey was conducted outside of the maternity season, but based on the quantity of bat sign observed, there is high likelihood that this structure serves as a maternity roost location. Direct impacts to special-status bat species and/or bat maternity colonies that could occur include injury, mortality, maternity colony failures, and loss of young. Indirect impacts include loss of roosting habitat, and increase in anthropogenic effects (i.e., noise levels, increase in human activity, increase in dust). Impacts to these species and maternity roosting sites could be considered significant; therefore, implementation of BIO-2, BIO-6, and BIO-7 is recommended.

5.1.2 Sensitive Natural Communities

The 287-acre Project Site and accompanying access road is comprised of creosote bush scrub, iodine bush scrub, disturbed-iodine bush scrub, blue palo verde – ironwood woodland, bush seepweed scrub, disturbed-bush seepweed scrub, disturbed-tamarisk thickets, fourwing saltbush scrub, and disturbed-fourwing saltbush scrub. which could be directly impacted by the Project. There is also tamarisk thicket, arrowweed thickets, active agriculture, disturbed, aqueduct, and all the communities listed within the Project Site within the Project buffer area. Blue palo verde – ironwood woodland, bush seepweed scrub, and iodine bush scrub are considered CDFW sensitive plant communities. In-kind mitigation, up to a 3:1 ratio, may be required by CDFW to offset impacts to these communities in order to reduce impacts to a less than significant level. This type of mitigation can include the purchase of credits from a mitigation

bank and/or compensatory mitigation. Implementation of BIO-8 is recommended to reduce potential impacts.

5.1.3 State- and/or Federally Protected Wetlands and Waters

The results of the Jurisdictional Aquatic Resources Delineation and discussion of potential impacts on state or federally protected wetlands or Waters of the U.S. are discussed in the *Jurisdictional Delineation Report* prepared under separate cover (Hernandez Environmental Services 2022).

5.1.4 Wildlife Corridors and Nursery Sites

The Project Site is located in generally undeveloped open space but is adjacent to areas containing existing disturbances (i.e., roads and active agricultural land). The Project Site is not in a recognized species corridor or habitat linkage, but the majority of the site contains suitable vegetation and/or cover to support some wildlife movement. However, due to the Coachella Canal, wildlife movement opportunities connecting the Project Site to large, undeveloped natural areas is limited. However, the desert scrub and woodland habitats could act as a potential corridor and nursery site for migrating wildlife species. Additionally, the abandoned building present in the northwest corner of the Project Site may serve as a native wildlife nursery site for roosting bats. Therefore, implementation of BIO-2, BIO-4, BIO-5, and BIO-6 are recommended to mitigate for potential significant impacts to potential nursery sites

5.1.5 Habitat and Conservation Plans and Natural Community Conservation

The Project is located in a DRECP Area but does not fall into an ACEC. The Project will follow the guidelines in Imperial County's Conservation and Open Space Element and meet the requirements outlined in the plan. Consultation with BLM, County of Imperial Department of Planning and Development, USFWS, and CDFW would be required should listed plant or wildlife species be found to occur.

6.0 RECOMMENDATIONS AND MITIGATION MEASURES

ECORP developed the following recommendations in accordance with the CEQA impacts analysis for the Project (Section 5) but should not be considered mitigation measures at this point in the Project planning process. These actions are recommended prior to Project implementation:

BIO-1: Rare Plant Surveys. Rare plant surveys should be conducted within suitable habitat within the Project Site during the appropriate blooming period for the Orocopia sage (approximately March through April), Harwood's milk-vetch (approximately January through May), and Munz's cholla (approximately May). The surveys should be conducted by a botanist or qualified biologist in accordance with the USFWS *Guidelines for Conducting and Reporting Botanical Inventories for Federally Listed, Proposed, and Candidate Plants* (USFWS 1996); the CDFW *Protocols for Surveying and Evaluating Impacts to Special Status Native Plant Populations and Sensitive Natural Communities* (CDFW 2018); and the CNPS *Botanical Survey Guidelines* (CNPS 2001). If any special-status species are observed during the rare plant surveys, the location of the individual plant or population will be recorded with a

submeter GPS device for mapping purposes. If Project-related impacts to rare plants within the Project Site are unavoidable, consultation with CDFW may be required to develop a mitigation plan or additional avoidance and minimization measures. Mitigation measures that may be implemented if the species is observed include establishing a no-disturbance buffer around locations of individuals or a population, salvage or seed collection, and additional monitoring requirements.

- BIO-2: Biological Monitoring.** A qualified biologist should be present to monitor all ground-disturbing and vegetation-clearing activities conducted for the Project. During each monitoring day, the biological monitor should perform clearance survey *sweeps* at the start of each work day that vegetation clearing takes place to minimize impacts on special-status species with potential to occur (including, but not limited to, special-status and/or nesting bird species, special-status bat species, monarch butterfly, desert kit fox, flat-tailed horned lizard). The monitor will be responsible for ensuring that impacts to special-status species, nesting birds, and active nests will be avoided to the greatest extent possible. Biological monitoring should take place until the Project Site has been completely cleared of any vegetation. If an active nest is identified, the biological monitor should establish an appropriate disturbance limit buffer around the nest using flagging or staking. Construction activities should not occur within any disturbance limit buffer zones until the nest is deemed no longer active by the biologist. If special-status wildlife species are detected during biological monitoring activities, consultation with the USFWS and/or CDFW should be conducted and a mitigation plan should be developed to avoid and offset impacts to these species. Mitigation measures may consist of work restrictions or additional biological monitoring activities after ground-disturbing activities are complete.
- BIO-3: Burrowing Owl Surveys.** Suitable habitat for burrowing owl was identified throughout the Survey Area. Focused burrowing owl surveys and preconstruction burrowing owl surveys are recommended. The focused burrowing owl surveys should follow the methods described in the CDFW's *Staff Report on Burrowing Owl Mitigation* (CDFG 2012). Four surveys should be conducted between February 15 and July 15, with at least one visit occurring before April 15 and one visit occurring after June 15. Pre-construction surveys for burrowing owl should be conducted within the Project Site and adjacent areas prior to the start of ground-disturbing activities. The surveys should follow the methods described in the CDFW's *Staff Report on Burrowing Owl Mitigation* (CDFG 2012). Two surveys should be conducted, with the first survey being conducted between 30 and 14 days before initial ground disturbance (e.g., grading, grubbing, and construction), and the second survey being conducted no more than 24 hours prior to initial ground disturbance. If burrowing owls and/or suitable burrowing owl burrows with sign (e.g., whitewash, pellets, feathers, prey remains) are identified within the Survey Area during the survey and impacts to those features are unavoidable, consultation with the CDFW should be conducted and the methods described in the CDFW's *Staff Report on Burrowing Owl Mitigation* (CDFG 2012) for avoidance and/or passive relocation should be followed.

- BIO-4: Pre-Construction Nesting Bird Survey.** If construction or other Project activities are scheduled to occur during the bird breeding season (typically February 1 through August 31 for raptors and March 15 through August 31 for the majority of migratory bird species), a qualified avian biologist should conduct a pre-construction nesting-bird survey to ensure that active bird nests will not be disturbed or destroyed. The survey should be completed no more than 3 days prior to initial ground disturbance. The nesting-bird survey should include the Project Site and adjacent areas where Project activities have the potential to affect active nests, either directly or indirectly due to construction activity or noise. If an active nest is identified, the biologist should establish an appropriately sized disturbance-limit buffer around the nest using flagging or staking. Construction activities should not occur within any disturbance-limit buffer zones until the nest is deemed inactive by the qualified biologist. If construction activities cease for a period of greater than 3 days during the bird breeding season, a pre-construction nesting bird survey should be conducted prior to the commencement of activities.
- BIO-5: Pre-Construction Survey for Special-Status Species.** A pre-construction survey should be conducted for special-status wildlife species within all areas of potential permanent and temporary disturbance. The pre-construction survey should take place no more than 14 days prior to the start of ground-disturbing activities. The pre-construction surveys should take place regardless of breeding season timing and should focus on identifying the presence of special-status wildlife species present within the Survey Area or that were identified as having a high/moderate potential to occur on the site. These species include, but are not limited to, flat-tailed horned lizard, burrowing owl, monarch butterfly, desert kit fox, loggerhead shrike, western yellow bat, Yuma myotis, American badger. Should any special-status species be identified during the pre-construction survey, consultation to develop suitable avoidance and minimization measures with the appropriate agency (i.e., USFWS, CDFW) may need to be undertaken.
- BIO-6: Compliance with Section 4150 of California Fish and Game Code.:** To avoid impacts to bat species, a qualified bat biologist should conduct an appropriate combination of sampling, exit counts, and acoustic surveys to determine if bats are using the palm tree resources in the Survey Area. If Project-related impacts to bat species are unavoidable, additional measures may need to be implemented to reduce or eliminate impacts to bat species, including maternity roosts, such as tree removal occurring outside of bat breeding season (October through February) or two-step, two-day removal of palm trees under supervision of a qualified bat biologist.
- BIO-7: Preparation of a Bat Management Plan.** Prior to initial site clearing activities, focused surveys for bat species shall be completed by a qualified bat biologist to determine the approximate size of the colony(s), species present, and features being used within the palm trees and bridge over the East Highline Canal. Focused surveys shall include a combination of nighttime emergence counts and acoustic techniques appropriate for the roosting habitat and time of year. At a minimum, focused surveys shall be conducted during the spring,

summer, fall, and winter to determine how the habitat is being used by bats throughout the year with at least two surveys conducted during the maternity season to determine a pre- and post-volant count of colonies present. If roosting bats are found during the surveys, a Bat Management Plan identifying situation-specific and species-specific avoidance and minimization measures to reduce impacts to roosting bats shall be prepared prior to the commencement of initial site clearing activities. The Bat Management Plan shall include, as appropriate to the findings of the focused surveys and roosting habitat affected, spatial and temporal avoidance measures, no-disturbance buffers, passive exclusion of bats outside of the maternity season (if necessary), and identification of species-specific replacement or alternative habitat to mitigate for permanent maternity roosting habitat loss.

BIO-8: Avoidance and Mitigation Measures for Sensitive Vegetation Communities. Temporary exclusion measures to prevent the potential impact to sensitive vegetation communities should be set up before the start of construction by a qualified biologist who can identify the vegetation communities that are known to occur in the area. These vegetation communities include blue palo verde – ironwood woodland, bush seepweed scrub, and iodine bush scrub. Exclusion measures can include flagging, fencing, and/or other exclusion measures that prevent equipment and/or personnel from impacting the vegetation. Having (a) biological monitor(s) present during construction, and environmental awareness training for every crew member on site before construction should also lessen the potential impacts that can occur. Consultation to develop suitable avoidance and minimization measures with the appropriate agency (i.e., USFWS, CDFW) may also need to be undertaken.

The following best management practices are not mitigation measures pursuant to CEQA but are recommended to further reduce impacts to special-status species that have potential to occur on the property:

- Confine all work activities to a pre-determined work area.
- To prevent inadvertent entrapment of wildlife during the construction phase of the Project, all excavated, steep-walled holes or trenches more than 2 feet deep should be covered at the close of each working day by plywood or similar materials. If the trenches cannot be closed, one or more escape ramps constructed of earthen fill or wooden planks should be installed. They should be thoroughly inspected for trapped wildlife before such holes or trenches are filled.
- Wildlife are often attracted to burrow- or den-like structures such as pipes, and may enter stored pipes and become trapped or injured. To prevent wildlife use of these structures, all construction pipes, culverts, or similar structures with a diameter of 4 inches or greater should be capped while stored onsite.
- All food-related trash items such as wrappers, cans, bottles, and food scraps should be disposed of in securely closed containers and removed at least once a week from a construction or Project Site.
- Use of rodenticides and herbicides within the Project Site should be restricted. This is necessary to prevent primary or secondary poisoning of wildlife, including

burrowing owl and the depletion of prey populations on which they depend. All uses of such compounds should observe label and other restrictions mandated by the USEPA, California Department of Food and Agriculture, and other state and federal legislation. If rodent control must be conducted, zinc phosphide should be used because of a proven lower risk to burrowing owl.

7.0 CERTIFICATION

I hereby certify that the statements furnished above and in the attached exhibits present the data and information required for this biological evaluation, and that the facts, statements, and information presented are true and correct to the best of my knowledge and belief. Field work conducted for this assessment was performed by me or under my direct supervision. I certify that I have not signed a non-disclosure or consultant confidentiality agreement with the project applicant or the applicant's representative and that I have no financial interest in the project.

Signed: _____ Date: January XX, 2023
Greg Hampton
Staff Biologist

Signed: _____ Date: January XX, 2023
Lauren Simpson
Senior Biologist

8.0 REFERENCES

- American Ornithologist's Union (AOU). 2022. Check-list of North American Birds. Available online: <http://www.aou.org>.
- Baldwin, B. G., D. H. Goldman, D. J. Keil, R. Patterson, T. J. Rosatti, and D. H. Wilken, editors. 2012. The Jepson Manual: Vascular Plants of California, Second Edition. University of California Press, Berkeley, California. 1400 pp.
- Bradley, R.D., L. K. Ammerman, R.J. Baker, L.C. Bradley, J. A Cook, R. C. Dowler, C. Jones, D. J Schmidly, F.B. Stangl, Jr., R.A. Van Den Bussche, B. Wursig. 2014. Revised Checklist of North American Mammals North of Mexico. Museum of Texas Tech University.
- CalFlora: Information on California plants for education, research and conservation. [Web application]. 2022. Berkeley, California: The CalFlora Database [a non-profit organization]. Available online: <http://www.calflora.org>.
- California Department of Conservation. 2018. Imperial County Important Farmland Map
- California Department of Fish and Game (CDFG). 2012. Staff Report on Burrowing Owl Mitigation. Dated March 7.
- _____. 1984. California Endangered Species Act. California Code of Regulations, Title 14, Chapter 5, Section 460. California Office of Administrative Law. Sacramento, CA.
- California Department of Fish and Wildlife (CDFW). 2022a. California Natural Diversity Database. Rarefind 5 [computer program]. Sacramento (CA): State of California, the Resources Agency, Department of Fish and Wildlife. Accessed on September 14, 2020 and April 5, 2022.
- _____. 2022b. Biogeographic Information and Observation System (BIOS). Biogeographic Data Branch. Sacramento, CA. <https://wildlife.ca.gov/Data/BIOS>.
- _____. 2022c. Special Animals List. Sacramento (CA): State of California, the Resources Agency, Department of Fish and Wildlife.
- _____. 2022d. State and Federally Listed Endangered and Threatened Animals of California. Sacramento (CA): State of California, Natural Resources Agency, Department of Fish and Wildlife. Dated April 2022.
- _____. 2022e. Vegetation Classification and Mapping Program (VegCAMP), website. California Department of Fish and Wildlife, Biogeographic Data Branch. Available at: <https://www.wildlife.ca.gov/Data/VegCAMP>
- _____. 2018. Protocols for Surveying and Evaluating Impacts to Special Status Native Plant Populations and Sensitive Natural Communities. Sacramento, California.

- California Native Plant Society (CNPS). 2022. Inventory of Rare and Endangered Plants (online edition, v7-08c). Rare Plant Scientific Advisory Committee. California Native Plant Society. Sacramento, CA. Available online: <http://www.cnps.org/inventory>.
- _____. 2001. Inventory of Rare and Endangered Plants of California (sixth edition). Rare Plant Scientific Advisory Committee, David P. Tibor, Convening Editor. California Native Plant Society, Sacramento, CA. 388pp.
- ECORP. 2022. *Jurisdictional Delineation for ECORP Consulting, Inc. North Star 2 ECORP Project Number: 2022-103*. Prepared for Don Mitchell December 2022.
- County of Imperial, Planning and Development Services Department. 2006. Imperial County Conservation and Open Space Element, El Centro, CA.
- Holland, R. 1986. Preliminary Descriptions of the Terrestrial Natural Communities of California. Department of Fish and Game, Sacramento, CA.
- iNaturalist. 2022. Available online at: <https://www.inaturalist.org>.
- Natural Resources Conservation Service (NRCS). 2022a. Online Web Soil Survey. U.S. Department of Agriculture. Accessed on September 27, 2020. Available online: <http://websoilsurvey.nrcs.usda.gov>.
- Sawyer, J. O., T. Keeler-Wolf, and J. M. Evens. 2009. *A Manual of California Vegetation, 2nd ed.* California Native Plant Society, Sacramento, CA.
- Skinner, M. W., and Pavlik (eds.). 1994. *Inventory of Rare and Endangered Vascular Plants of California; Fifth Edition*. California Native Plant Society, Sacramento, California.
- Society for the Study of Amphibians and Reptiles (SSAR). 2017. Scientific and Standard English Names of Amphibians and Reptiles of North American North of Mexico, With Comments Regarding Confidence in our Understanding. Eighth Edition. Committee on Standard English and Scientific Names.
- State Water Resources Control Board. 2021. State Policy for Water Quality Control: State Wetland Definition and Procedures for Discharges of Dredged or Fill Material to Waters of the State. Adopted April 2, 2020 and Revised April 6, 2021.
- U.S. Army Corps of Engineers (USACE). 1996. 1996 National List of Vascular Plant Species That Occur in Wetlands. Available online: https://mde.maryland.gov/programs/Water/WetlandsandWaterways/DocumentsandInformation/Documents/www.usace.army.mil/CECW/Documents/cecwo/reg/plants/I96_intro.pdf.
- U.S. Fish and Wildlife Service (USFWS). 2022a. National Wetland Inventory. <https://www.fws.gov/wetlands/data/Mapper.html>. Accessed on September 24, 2020 and April 22, 2022.

- ____. 2022b. Information for Planning and Consultation Trust Resources List. <http://ecos.fws.gov/ipac/>. Accessed on September 24, 2020 and April 26, 2022.
- ____. 1996. USFWS Guidelines for Conducting and Reporting Botanical Inventories for Federally Listed, Proposed, and Candidate Plants.
- ____. 1918. Migratory Bird Treaty Act of 1918. Section 16 of the U.S. Code (703-712), as amended 1989.

LIST OF APPENDICES

Appendix A – Representative Site Photographs

Appendix B – Special-Status Plant Potential For Occurrence

Appendix C – Special-Status Wildlife Potential For Occurrence

Appendix D – Plant Species Observed

Appendix E – Wildlife Species Observed

APPENDIX A

Representative Site Photographs



Photo 1: Creosote bush scrub habitat.



Photo 2: Arrowweed thickets habitat.



Photo 3: Blue palo verde – ironwood woodland habitat.



Photo 4: Bush seepweed scrub habitat.



Photo 5: Fourwing saltbush scrub habitat.



Photo 6: Disturbed- bush seepweed scrub habitat.



Photo 7: Disturbed- tamarisk thickets habitat.



Photo 8: Disturbed- iodine bush scrub habitat.



Photo 9: Disturbed habitat.



Photo 10: Exterior of bat roost outhouse structure.



Photo 11: Interior of bat roost outhouse structure.



Photo 12: Exterior of bat roost building.



Photo 13: Interior of bat roost building, guano and staining visible.



Photo 14: Interior of bat roost building, guano pile on floor.

Special-Status Plant Potential For Occurrence

Appendix B – Special-Status Species Plants Potential for Occurrence within the Project Site

Scientific Name Common Name	Status	Blooming Period/ Elevation Range (meters)	Habitat	Potential to Occur within the Project Site
<i>Astragalus insularis</i> var. <i>harwoodii</i> Harwood's milk- vetch	USFWS: None CDFW: None CRPR: 2B.2 BLM: None	Jan-May (0 - 2710)	Mojavean desert scrub Desert dunes	High: One recent (2005) CNDDDB record was located less than one mile east of the Project site near the Gas Line Road. Potential habitat occurs within the Project site for this species in the creosote bush scrub habitats.
<i>Astragalus sabulonum</i> gravel milk-vetch	USFWS: None CDFW: None CRPR: 2B.2 BLM: Sensitive	Feb-Jun (-60 - 930)	Desert dunes Mojavean desert scrub Sonoran desert scrub	Low: Habitat for this species occurs within the Project site; one historical occurrence (1906) exists greater than five miles away.
<i>Chylismia arenaria</i> Sand evening- primrose	USFWS: None CDFW: None CRPR: 2B.2 BLM: None	Nov-May (-70 - 915)	Sonoran desert scrub	Low: Habitat for this species occurs within the Project site; one known historical occurrence (1993) exists greater than five miles away.
<i>Colubrina californica</i> Las Animas colubrina	USFWS: None CDFW: None CRPR: 2B.3 BLM: None	Apr-Jun (10 - 1000)	Mojavean desert scrub Sonoran desert scrub	Low: Habitat for this species occurs within the Project site; known occurrences exists greater than five miles away.
<i>Cylindropuntia munzii</i> Munz's cholla	USFWS: None CDFW: None CRPR: 1B.3 BLM: Sensitive	May (150 - 600)	Sonoran desert scrub	High: Recent (2017) CNDDDB record observations was approximately 5 miles east of the Project site in large portions of the Chocolate Mountain Aerial Gunnery Range. Potential habitat occurs within the Project site for this species in the creosote bush scrub habitats.

Scientific Name Common Name	Status	Blooming Period/ Elevation Range (meters)	Habitat	Potential to Occur within the Project Site
<i>Ditaxis claryana</i> Glandular ditaxis	USFWS: None CDFW: None CRPR: 1B.2 BLM: None	Oct-Mar (0 – 465)	Mojavean desert scrub Sonoran desert scrub	Low: Habitat for this species occurs within the Project site; one known historical occurrence (1978) exists greater than five miles away.
<i>Petalonyx linearis</i> Narrow-leaf sandpaper-plant	USFWS: None CDFW: None CRPR: 2B.3 BLM: None	(Jan-Feb) Mar- May (Jun-Dec) (-25 - 1115)	Mojavean desert scrub Sonoran desert scrub	Low: Habitat for this species occurs within the Project site; one known historical occurrence (1949) exists greater than five miles away.
<i>Salvia greatae</i> Orocopia sage	USFWS: None CDFW: None CRPR: 1B.3 BLM: Sensitive	Mar-Apr (-40 - 825)	Mojavean desert scrub Sonoran desert scrub	Moderate: One historic (1990) CNDDDB record was located approximately five miles northwest of the Project site near the Siphon Seventeen. Potential habitat occurs within the Project site for this species.
California Native Plant Society (CNPS) Rare Plant Ranks: 1B: Plants rare, threatened, and endangered in California and elsewhere. 2B: Plants rare, threatened, or endangered in California, but more common elsewhere. 4: Plants of limited distribution; a watch list.			CNPS Threat Ranks: 0.1: Seriously threatened in California (over 80% of occurrences threatened / high degree and immediacy of threat) 0.2: Fairly threatened in California (20-80% of occurrences threatened / moderate degree and immediacy of threat) 0.3: Not very threatened in California (less than 20% of occurrences threatened / low degree and immediacy of threat or no current threats known)	
Other Designations S: Bureau of Land Management Sensitive Species				

Sources:

California Natural Diversity Data Base (CNDDDB) (CDFW 2022)
 CNPS Rare and Endangered Plant Inventory (CNPS 2022)
 Calflora Information on California Plants (Calflora 2022)
 IPaC (USFWS 2020)
 Special Status Plants (BLM 2015)

Special-Status Wildlife Potential For Occurrence

Scientific Name Common Name	Status		Habitat Requirements	Potential for Occurrence
FISH				
<i>Cyprinodon macularius</i> Desert pupfish	Fed: Ca: BLM:	END END none	Shallow and slow-moving water features with sand or silt bottoms and aquatic plants. May include desert springs, marshes, lakes, and saline or stream pools.	Presumed Absent. Although several occurrences of this species have been documented along the shores of the Salton Sea, no suitable habitat occurs for this species within the Project Site.
<i>Xyrauchen texanus</i> Razorback sucker	Fed: Ca: BLM:	END END none	Rivers with backwaters, deep runs, flooded off-channels in the spring. Shallow runs and pools in summer. Slow flowing runs and eddies in winter.	Presumed Absent. Although the literature search revealed four records of this species, all were historic (between 1949 and 1994). Further, no suitable habitat occurs for this species within the Project Site.
AMPHIBIANS				
<i>Incilius alvarius</i> Sonoran Desert toad	Fed: Ca: BLM:	none SSC none	Creosote bush desert scrub, grasslands up into oak-pine woodlands, thorn scrub and tropical deciduous forest in Mexico.	Presumed Absent. While marginally suitable habitat is present adjacent to the Project Site in the Survey Area in the agricultural drainage on the west side of the site, this species is believed to be extirpated from California. One CNDDDB result from 1916 approx. 5 miles SE of Project Site along HWY 111.
<i>Lithobates yavapaiensis</i> Lowland leopard frog	Fed: Ca: BLM:	none SSC S	Rocky streams in canyons adjacent to conifer forests or in scrub desert ponds and stream pools.	Presumed Absent. No suitable habitat occurs for this species within the Project Site. This species is believed to be possibly extirpated from California. One CNDDDB result from 1940 approx. 4.5 miles south of project site along HWY 111.
<i>Scaphiopus couchii</i> Couch's spadefoot	Fed: Ca: BLM:	none SSC S	Underground in arid and desert regions of creosote bush, grassland, thorn forest, and sandy washes. Surfaces during rain events.	Moderate. Suitable habitat for this species exists in the creosote bush scrub within the Project Site. One CNDDDB result from 2007 four miles south of project site along HWY 111.

Scientific Name Common Name	Status	Habitat Requirements	Potential for Occurrence
REPTILES			
<i>Gopherus agassizii</i> Desert tortoise	Fed: Ca: BLM:	THR THR S	Desert valleys with vegetation communities such as alluvial fan, saltbush, creosote bush, desert scrub, and tree yuccas. Burrows in soil, under rocks, and along washes.
<i>Phrynosoma mcallii</i> Flat-tailed horned lizard	Fed: Ca: BLM:	none SSC S	Desert scrub on sandy flats and valleys with little or no windblown sand, salt flats, and areas with gravelly soils.
BIRDS			
<i>Asio otus</i> Long-eared owl	Fed: Ca: BLM:	none SSC none	Dense wooded areas such as deciduous and evergreen forests. Prefers dense trees for nesting and/or roosting adjacent to open areas for hunting. Found in a variety of woodland habitats including forests adjacent to meadows and streamside desert groves.
<i>Athene cunicularia</i> Burrowing owl	Fed: Ca: BLM:	none SSC S	Open grasslands including prairies, plains, and savannah, or vacant lots and airports. Nests in abandoned dirt burrows.
<i>Charadrius nivosus nivosus</i> Western snowy plover	Fed: Ca: BLM:	THR SSC none	Sandy beaches, salt pond levees & shores of large alkali lakes. Needs sandy, gravelly, or friable soils for nesting. Known
			Low. Two historic and two modern records have been documented in the CNDDDB from 1987-2007 in the Chocolate Mountain/Chuckwalla valley area - which is at least 9 miles from Project Site. While suitable habitat is present in the Project Site, connectivity to these known populations is limited due to development/disturbances, unsuitable habitat, and physical barriers.
			Moderate. Suitable habitat for this species exists in the desert scrub habitats within the Project Site. Two CNDDDB records from 1966 and 2015 are located 8-10 miles northwest of the project site, north of Salton Sea.
			Present. Two individuals were observed in the Survey Area along the northern gen-tie in the blue palo verde - ironwood woodland community during the 2022 biological reconnaissance survey. No CNDDDB records were documented within 5 miles of the Project Site.
			High. Suitable habitat for this species exists throughout the Project Site. Over 30 CNDDDB records have been documented from 2006-2007 scattered southwest, southeast, and south of the Project Site with at least 1 nesting pair estimated at each location.
			Presumed Absent. While records of wintering western snowy plovers are prevalent at the nearby shores of the Salton Sea, no suitable habitat occurs

Scientific Name Common Name	Status		Habitat Requirements	Potential for Occurrence
			protected population in the Tijuana Estuary.	for this species within the Project Site.
<i>Charadrius montanus</i> Mountain plover	Fed: Ca: BLM:	none SSC S	Shrubland and grassland, particularly in heavily graded shortgrass prairie, fallow fields, and xeric scrub. Known to winter in semi-desert agricultural land.	Presumed Absent. While records of wintering mountain plovers are prevalent in agricultural fields south of the Survey Area, no suitable habitat occurs for this species within the Project Site.
<i>Coccyzus americanus occidentalis</i> Western yellow-billed cuckoo	Fed: Ca: BLM:	THR END none	Open woodland habitat, near water, especially with dense willow and cottonwood understory. Requires broad riparian forest habitat (usually >50 acres).	Presumed Absent. Although the USFWS species occurrence data revealed four records of this species observed between 1977 and 2019, all but one record (from 1977) were greater than five miles from the Project Site. In addition, no suitable habitat for this species was present on the Project Site or in the Survey Area.
<i>Empidonax traillii ssp. extimus</i> Southwestern willow flycatcher	Fed: Ca: BLM:	END END S	Riparian woodlands particularly with willow thickets. Nests in densest areas of shrubs and trees with low-density canopies.	Low. Marginally suitable habitat for this species exists in the tamarisk and arrowweed thickets in the adjacent East Highline Canal; however, these habitats are outside of the Project Site in the Survey Area. One CNDDDB record from 2007 documented five pairs less than 2 miles SE of project site along the East Highline canal.
<i>Gelochelidon nilotica</i> Gull-billed tern (nesting colony)	Fed: Ca: BLM:	none SSC none	Salt marshes, estuaries, coastlines, and plowed fields. Nests on beaches, sandy shores of salt marshes, and sandy barrier islands.	Presumed Absent. While records of gull-billed tern are prevalent at the nearby shores of the Salton Sea, no suitable habitat occurs for this species within the Project Site.
<i>Icteria virens</i> Yellow-breasted chat	Fed: Ca: BLM:	none SSC none	Riparian and upland thickets, and dry overgrown pastures. Prefers to nest in dense scrub along streams or at the edges of ponds or swamps.	Low. Marginally suitable habitat for this species exists in the tamarisk and arrowweed thickets in the adjacent East Highline Canal however these habitats are outside of the Project Site in the Survey Area. Two historic CNDDDB records from 1960 and 1961 are located west of the project site along the eastern edge of the Salton Sea. Additionally, several

Scientific Name Common Name	Status		Habitat Requirements	Potential for Occurrence
				recent eBird records of this species have been documented approximately 3.5 miles southwest of the Project Site.
<p><i>Lanius ludovicianus</i></p> <p>Loggerhead shrike (nesting)</p>	<p>Fed:</p> <p>Ca:</p> <p>BLM:</p>	<p>none</p> <p>SSC</p> <p>none</p>	<p>Open country, with scattered shrubs and trees or other perches for hunting; includes agricultural fields, deserts, grasslands, savanna, and chaparral. Nests 2.5 to 4 feet off ground in thorny vegetation.</p>	<p>Present. One individual was observed onsite during the 2022 biological reconnaissance survey. Additionally, one CNDDDB record from 2007 documents 3 adults and 2 juveniles approximately 13 miles southeast of the Project Site.</p>
<p><i>Laterallus jamaicensis coturniculus</i></p> <p>California black rail</p>	<p>Fed:</p> <p>Ca:</p> <p>BLM:</p>	<p>none</p> <p>THR, FP</p> <p>S</p>	<p>Coastal and estuarine saltmarshes especially dominated by pickleweed and matted salt grass. Freshwater marshes with shallow and stable water levels and flat shorelines.</p>	<p>Low. Marginally suitable habitat for this species exists in the tamarisk and arrowweed thickets in the adjacent East Highline Canal; however, these habitats are outside of the Project Site in the Survey Area. Twelve CNDDDB records from 1947-2015 are distributed between 2-14 miles of the Project Site. Some records reference wetland habitat that has since been converted to agricultural lands.</p>
<p><i>Melanerpes uropygialis</i></p> <p>Gila woodpecker</p>	<p>Fed:</p> <p>Ca:</p> <p>BLM:</p>	<p>none</p> <p>END</p> <p>S</p>	<p>Arid environments, especially deserts and dry forests of the southwestern U.S. and adjacent Mexico, usually below elevations of 3,300 feet. Most common in low swales and arroyos, including riparian corridors with cottonwood, willow, and mesquite. Nests in cacti and other tree species.</p>	<p>Low. Marginally suitable habitat for this species exists in the tamarisk and arrowweed thickets in the adjacent East Highline Canal; however, these habitats are outside of the Project Site in the Survey Area. One historic CNDDDB occurrence from 1950 on agricultural land about 12 miles south of Project Site. Additionally, several recent eBird records of this species have been documented approximately 3.5 miles southwest of the Project Site.</p>

Scientific Name Common Name	Status		Habitat Requirements	Potential for Occurrence
<i>Pelecanus occidentalis californicus</i> California brown pelican	Fed: Ca: BLM:	DL DL S	Coastal marine habitats including estuaries. Nests on ground in dense vegetation or on bare sand, or in exposed treetop.	Presumed Absent. While records of California brown pelican are prevalent at the nearby shores of the Salton Sea, no suitable habitat occurs for this species within the Project Site.
<i>Rallus obsoletus ssp. yumanensis</i> Yuma Ridgway's rail	Fed: Ca: BLM:	END THR, FP none	Consistently found in freshwater marshes that are composed of cattail and bulrush. This emergent vegetation averages greater than 6 feet tall. Water depth tends to be around 3.5 inches deep. Range extends from Nevada, California, and Arizona to Baja California and Sonora Mexico.	Low. Marginally suitable habitat for this species exists in the tamarisk and arrowweed thickets in the adjacent East Highline Canal; however, these habitats are outside of the Project Site in the Survey Area. Thirteen CNDDDB records from 1978-2009 are distributed between 1-14 miles of the Project Site. Each of these record documents multiple breeding pairs. Additionally, several recent eBird records of this species have been documented approximately 3.5 miles southwest of the Project Site.
<i>Rynchops niger</i> Black skimmer	Fed: Ca: BLM:	none SSC none	Wetlands (inland), marine subtidal and intertidal on rock, sand, and muddy habitat.	Presumed Absent. While records of black skimmer are prevalent at the nearby shores of the Salton Sea, no suitable habitat occurs for this species within the Project Site.
<i>Setophaga petechia</i> Yellow warbler	Fed: Ca: BLM:	none SSC none	Riparian woodlands especially with willows, open scrub, gardens, and thickets often near water.	Low. Marginally suitable habitat for this species exists in the tamarisk and arrowweed thickets in the adjacent East Highline Canal however these habitats are outside of the Project Site in the Survey Area. One historic CNDDDB record from 1952 was documented about 5 miles south of the Project Site. Additionally, observations have been documented in eBird as recently as 2017 within three miles of the Project Site.

Scientific Name Common Name	Status		Habitat Requirements	Potential for Occurrence
<i>Toxostoma crissale</i> Crissal thrasher	Fed: Ca: BLM:	none SSC S	Desert scrub and riparian brush with dense mesquite thickets often near streams or washes.	Low. The desert scrub habitat in the Project Site would be considered marginal for this species due to a lack of dense mesquite thickets. One historical CNDDDB record from 1969 was documented 8 miles south of the Project Site.
<i>Vireo bellii pusillus</i> Least Bell's vireo	Fed: Ca: BLM:	END END none	Occurs in riparian woodlands and willow-cottonwood forests particularly with streamside thickets and dense brush	Presumed Absent. Although the USFWS species occurrence data revealed one record of this species from 2017, this record was approximately 8 miles from the Project Site. In addition, no suitable habitat for this species was present on the Project Site or in the Survey Area.
MAMMALS				
<i>Antrozous pallidus</i> Pallid bat	Fed: Ca: BLM:	none SSC S	Roosts in rock crevices, caves, mines, buildings, bridges, and in trees. Generally, in mountainous areas, lowland desert scrub, arid grasslands near water and rocky outcrops, and open woodlands.	High. The abandoned building located in the northwest corner of the site provides suitable roosting habitat for this species and guano was observed inside. Also observed inside were signs typical of pallid bat night-roosting including moth wings and large culled insect parts. One CNDDDB record from 1994 documented a roost site approx. 6 miles NE of project site.
<i>Corynorhinus townsendii</i> Townsend's big-eared bat	Fed: Ca: BLM:	none SSC S	Roosts in mines, caves, buildings, bridges, or other cavities. Prefers hollow cavity roosting spaces.	Moderate. The abandoned building located in the northwest corner of the site provides suitable roosting habitat for this species and bat guano of unknown species was observed inside. No CNDDDB records were documented within 5 miles of the Project Site.
<i>Eumops perotis</i> ssp. <i>californicus</i> Western mastiff bat	Fed: Ca: BLM:	none SSC S	Roosts high above ground in rock and cliff crevices, shallow caves, and rarely in tall buildings. Occurs in arid and semiarid regions including rocky canyon habitats.	Presumed Absent. Although some foraging habitat exists within the Survey Area, no cliff or rocky outcrop roosting habitat for this species is present. Two historic CNDDDB occurrences in 1994 documented several individuals

Scientific Name Common Name	Status		Habitat Requirements	Potential for Occurrence
				between 4 to 6 miles from the Project Site.
<i>Lasiurus xanthinus</i> Western yellow bat	Fed: Ca: BLM:	none SSC none	Roosts in trees, especially in fan palms with dead fronds. Found in riparian woodlands in arid regions, oak or pinyon-juniper woodlands, and human developed areas.	Presumed Absent. Although some foraging habitat exists within the Survey Area, no palm trees or other riparian roosting habitat for this species is present. One CNDDDB record from 1983 was documented approximately eight miles north of the Project Site in the Chocolate mountains.
<i>Myotis ciliolabrum</i> Small-footed myotis	Fed: Ca: BLM:	none none S	Roosts in rock crevices and cracks, caves, and mines. Maternity roosts include abandoned buildings. Occurs in in deserts, badlands, woodlands, riparian areas, and near outcrops and cliffs.	Moderate. The abandoned building located in the northwest corner of the site provides suitable roosting habitat for this species and bat guano of unknown species was observed inside. No CNDDDB records were documented within 5 miles of the Project Site.
<i>Myotis evotis</i> Long-eared myotis	Fed: Ca: BLM:	none none S	Roosts in trees, mines, caves, and erosional cavities and rock crevices. Sometimes roosts in buildings. Found in woodlands ranging from lowland to subalpine, shrublands, riparian areas, and meadows.	Low. The abandoned building located in the northwest corner of the site may provide suitable roosting habitat for this species and bat guano of unknown species was observed inside. No CNDDDB records were documented within 5 miles of the Project Site.
<i>Myotis thysanodes</i> Fringed myotis	Fed: Ca: BLM:	none none S	Roosts in cliff faces, rock crevices, mines, caves, tree snags, and in man-made structures. Most common at mid elevations in deserts, riparian areas, woodlands, and grasslands.	Moderate. The abandoned building located in the northwest corner of the site provides suitable roosting habitat for this species and bat guano of unknown species was observed inside. No CNDDDB records were documented within 5 miles of the Project Site.

Scientific Name Common Name	Status		Habitat Requirements	Potential for Occurrence
<i>Myotis yumanensis</i> Yuma myotis	Fed: Ca: BLM:	none none S	Roosts near water in cliff crevices, caves, trees, buildings, and bridges. Occurs near water in riparian areas, moist woodlands and forests, and desert scrub.	High. The abandoned building located in the northwest corner of the site provides suitable roosting habitat for this species and bat guano of unknown species was observed inside. No CNDDDB records were documented within 5 miles of the Project Site.
<i>Nyctinomops femorosaccus</i> Pocketed free-tailed bat	Fed: Ca: BLM:	none SSC none	Roosts in crevices of outcrops and cliffs, shallow caves, and tall buildings. Found along rugged canyons, high cliffs, and semiarid rock outcroppings.	Presumed Absent. Although some foraging habitat exists within the Survey Area, no cliff or rocky outcrop roosting habitat for this species is present. One CNDDDB record from 1994 documented a few individuals foraging approximately 4 miles southeast of project site.
<i>Ovis canadensis nelsoni</i> Desert bighorn sheep	Fed: Ca: BLM:	none FP S	Open, steep, and rocky terrain in arid desert mountains particularly in southeastern California.	Presumed Absent. No suitable habitat is present within the Survey Area. One historic CNDDDB record from 1986 documented approximately 120 individuals in the northwest portion of the Chocolate Mountain range, about 12 miles from Project Site
<i>Sigmodon hispidus ssp. eremicus</i> Yuma hispid cotton rat	Fed: Ca: BLM:	none SSC none	Inhabits a variety of habitats, but generally associated with drainage ditches, canals, and seeps vegetated with plants such as arrow weed, salt grass, common reed, cattails, sedges, tamarisk, heliotrope, and annual grasses. They utilize runways through dense herbaceous growth and nests are built of woven grass. Noted presence in moist agricultural fields.	Low. Marginally suitable habitat for this species exists in the tamarisk and arrowweed thickets in the adjacent East Highline Canal; however, these habitats are outside of the Project Site in the Survey Area. Two CNDDDB records from 2008 documented three adults approximately 3 miles south of the Project Site and one adult approximately 9 miles southwest of the Project Site.
<i>Taxidea taxus</i> American badger	Fed: Ca: BLM:	none SSC none	Open habitats with friable soil such as grasslands, brushlands with sparse ground cover, open chaparral, and sometimes riparian zones.	Moderate. Suitable habitat for this species exists throughout most of the Survey Area. One historic CNDDDB record from 1937 documents 1 male approximately 8 miles south of the Project Site.

Scientific Name Common Name	Status		Habitat Requirements	Potential for Occurrence
<p><i>Vulpes macrotis arsipus</i></p> <p>Desert kit fox</p>	<p>Fed: Ca:</p>	<p>none CCR Title 14 Chapter 5 § 460</p>	<p>Occurs in desert habitats that include creosote bush, shadscale, greasewood, and sagebrush. This species feeds primarily on nocturnal rodents and rabbits, but will also opportunistically feed on birds, reptiles, and insects.</p>	<p>High. Although this species is not tracked in the CNDDDB, the Project Site contains suitable foraging and denning habitat for this species and inactive burrows that may have been dug by this species were observed onsite. This species could utilize the portions of the Project Site while foraging, denning, or moving through the area.</p>
<p>Federal Designations: (Federal Endangered Species Act, USFWS)</p> <p>END: Federally-listed, Endangered</p> <p>THR: Federally-listed, Threatened</p> <p>DL: Federally delisted</p>	<p>State Designations: (California Endangered Species Act, CDFW)</p> <p>END: State-listed, Endangered</p> <p>THR: State-listed, Threatened</p> <p>SSC: California Species of Special Concern</p> <p>DL: State delisted</p> <p>FP: Fully Protected Species</p>		<p>Bureau of Land Management (BLM) Classifications:</p> <p>S Bureau of Land Management Sensitive Species</p> <p>CCR Title 14 Chapter 5 § 460: Furbearing Mammals</p>	

APPENDIX D

Plant Species Observed

Scientific Name	Common Name
VASCULAR PLANTS	
ANGIOSPERMS (EUDICOTS)	
AMARANTHACEAE	AMARANTH FAMILY
<i>Tidestromia suffruticosa</i>	Honeysweet
ASTERACEAE	SUNFLOWER FAMILY
<i>Ambrosia dumosa</i>	Burrobush
<i>Encelia actoni</i>	Acton encelia
<i>Encelia farinosa</i>	Brittlebush
<i>Pluchea sericea</i>	Arrow weed
CACTACEAE	CACTUS FAMILY
<i>Cylindropuntia echinocarpa</i>	Silver cholla
<i>Cylindropuntia ramosissima</i>	Pencil cholla
<i>Ferocactus cylindraceus</i>	California barrel cactus
<i>Mammillaria tetrancistra</i>	Fishhook cactus
CHENOPODIACEAE	GOOSEFOOT FAMILY
<i>Allenrolfea occidentalis</i>	Iodine bush
<i>Atriplex canescens</i>	Fourwing saltbrush
<i>Atriplex hymenelytra</i>	Desert holly
<i>Salsola tragus*</i>	Russian thistle
<i>Suaeda nigra</i>	Bush seepweed
EUPHORBIACEAE	SPURGE FAMILY
<i>Euphorbia micromera</i>	Sonoran sandmat
<i>Euphorbia polycarpa</i>	Smallseed sandmat
FABACEAE	LEGUME FAMILY
<i>Olneya tesota</i>	Desert ironwood
<i>Parkinsonia florida</i>	Blue paloverde
<i>Psoralea schottii</i>	Schott's indigo bush
<i>Psoralea spinosus</i>	Smoke tree
SOLANACEAE	NIGHTSHADE FAMILY
<i>Lycium brevipes var. brevipes</i>	Desert thorn
TAMARICACEAE	TAMARISK FAMILY
<i>Tamarix ramosissima*</i>	Tamarisk
VISCACEAE	MISTLETOE FAMILY
<i>Phoradendron californicum</i>	California mesquite mistletoe
ZYGOPHYLLACEAE	CALTROP FAMILY
<i>Larrea tridentata</i>	South American creosote bush
ANGIOSPERMS (MONOCOTS)	
POACEAE	GRASS FAMILY
<i>Typha domingensis</i>	Narrowleaf cattail

* Not native to California.

APPENDIX E

Wildlife Species Observed

Wildlife Species Observed

Scientific Name	Common Name
REPTILES	
Phrynosomatidae	Spiny Lizards
<i>Callisaurus draconoides</i>	zebra-tailed lizard
<i>Uta stansburiana</i>	side-blotched lizard
Teiidae	Whiptails & Relatives
<i>Aspidoscelis tigris tigris</i>	great basin whiptail
BIRDS	
Accipitridae	Hawks, Kites, & Eagles
<i>Buteo jamaicensis</i>	red-tailed hawk
Aegithalidae	Bushtits
<i>Psaltriparus minimus</i>	bushtit
Ardeidae	Hérons and Egrets
<i>Ardea herodias</i>	great blue heron
Cathartidae	Vultures
<i>Cathartes aura</i>	turkey vulture
Charadriidae	Plovers and Lapwings
<i>Charadrius vociferus</i>	killdeer
Corvidae	Jays and Crows
<i>Corvus corax</i>	common raven
Falconidae	Falcons and Caracaras
<i>Falco sparverius</i>	American kestrel
Icteridae	Blackbirds & Orioles
<i>Agelaius phoeniceus</i>	red-winged blackbird
<i>Quiscalus mexicanus</i>	great-tailed grackle
Laniidae	Shrikes
<i>Lanius ludovicianus*</i>	loggerhead shrike
Parulidae	Wood Warblers
<i>Setophaga coronata</i>	yellow-rumped warbler
Passerellidae	Sparrows and Towhees
<i>Artemisiospiza nevadensis</i>	sagebrush sparrow
<i>Melospiza aberti</i>	Abert's towhee
<i>Zonotrichia leucophrys</i>	white-crowned sparrow
Pelecanidae	Pelicans
<i>Pelecanus erythrorhynchos</i>	American white pelican
Picidae	Woodpeckers & Allies
<i>Colaptes auratus</i>	Northern flicker
Poliophtilidae	Gnatcatchers
<i>Poliophtila melanura</i>	black-tailed gnatcatcher

Wildlife Species Observed

Scientific Name	Common Name
Remizidae	Penduline Tits
<i>Auriparus flaviceps</i>	verdin
Strigidae	True Owls
<i>Asio otus</i> *	long-eared owl
Troglodytidae	Wrens
<i>Salpinctes obsoletus</i>	rock wren
Tyrannidae	Tyrant Flycatchers
<i>Sayornis nigricans</i>	black phoebe
<i>Sayornis saya</i>	Say's phoebe
MAMMALS	
Leporidae	Rabbits and Hares
<i>Sylvilagus audubonii</i>	desert cottontail rabbit
Sciuridae	Squirrels
<i>Ammospermophilus leucurus</i>	white-tailed antelope squirrel

*CDFW California Species of Special Concern

Traffic, Parking and Circulation Assessment for the North Star 1 Project

Imperial County, California

Prepared For:

ZGlobal, Inc.
604 Sutter Street, Suite 250
Folsom, California 95630

Prepared By:

 **ECORP Consulting, Inc.**
ENVIRONMENTAL CONSULTANTS
2525 Warren Drive
Rocklin, California 95677

February 28, 2023

CONTENTS

1.0 INTRODUCTION 1

2.0 AFFECTED ENVIRONMENT 1

 2.1 Regulatory Setting 1

 2.1.1 State 1

 2.1.2 Local 2

3.0 ENVIRONMENTAL SETTING 6

 3.1 Existing Road Network 6

 3.1.1 State Roadways 6

 3.2 Existing Traffic Volumes 7

 3.3 Level of Service Standards 8

 3.3.1 Intersection Level of Service Definitions 8

 3.3.2 Existing Roadway Segment Operations 8

 3.3.3 Parking Facilities 9

4.0 ENVIRONMENTAL CONSEQUENCES AND MITIGATION MEASURES 9

 4.1 Significance Criteria 9

 4.2 CEQA Criteria 9

 4.3 Methods and Assumptions 9

 4.4 Trip Generation 10

 4.4.1 Construction 10

 4.4.2 Operation 11

 4.5 Impacts Not Discussed Further 12

 4.5.1 Impact Analysis and Mitigation Measures 12

5.0 REFERENCES 13

LIST OF TABLES

Table 1. Transportation and Circulation Standards of the Imperial County General Plan CSHE 4

Table 2. Existing Traffic Volumes on Project Vicinity Roadways 7

Table 3. LOS Definitions for Signalized and Unsignalized Intersections 8

Table 4. Project Trip Distribution 11

LIST OF ACRONYMS AND ABBREVIATIONS

Term	Definition
Caltrans	California Department of Transportation
CEQA	California Environmental Quality Act
County	Imperial County
CNRA	California Natural Resources Agency
CSHE	Circulation and Scenic Highways Element
GHG	Greenhouse Gas
HCM	Highway Capacity Manual
IVAG	Imperial Valley Association of Governments
LOS	Level of Service
MPO	Metropolitan Planning Organization
OPR	Office of Planning and Research
PRC	Public Resources Code
Project	North Star 2 Project
RCP	Regional Comprehensive Plan
RTP	Regional Transportation Plan
SB	Senate Bill
SCAG	Southern California Association of Governments
SCS	Sustainable Communities Strategy
SR	State Route
SRTP	Short Range Transit Plan
VMT	Vehicle Miles Traveled

1.0 INTRODUCTION

This Traffic, Parking and Circulation Assessment describes regulations related to transportation, parking, and circulation, and the existing transportation systems in the Project Vicinity; identifies significance criteria for impacts on transportation, parking, and circulation; and evaluates potential impacts associated with the Project alternatives. Consistency with Imperial County goals and policies is presented in the Regulatory Setting section. Cumulative transportation impacts are presented in the Environmental Consequences and Mitigation Measures section. The Project's effects on thresholds are described in the Significance Criteria section.

2.0 AFFECTED ENVIRONMENT

Several state, regional, and local transportation-related standards and criteria apply to the Project and are discussed in the Regulatory Setting section. Standards and performance targets are identified in the Circulation and Scenic Highways Element (CSHE) of the Imperial County General Plan.

2.1 Regulatory Setting

2.1.1 State

2.1.1.1 California Senate Bill 375

California's Senate Bill (SB) 375 requires regional Metropolitan Planning Organizations (MPO) to focus regional land use and transportation policies to reduce Greenhouse Gas (GHG) emissions from cars and light trucks in order to meet targets established by the California Air Resources Board with assistance from the Regional Targets Advisory Committee. SB 375 calls for each MPO to develop a Sustainable Communities Strategy (SCS) with its Regional Transportation Plan, identifying the transportation, land use, and housing strategies that will reduce regional GHG emissions.

2.1.1.2 Department of Transportation

The California Department of Transportation (Caltrans) is responsible for the design, construction, maintenance, and operation of the California State highway system, as well as that portion of the Interstate highway system within the state's boundaries. Alone and in partnership with Amtrak, Caltrans is also involved in the support of intercity passenger rail service in California and is a leader in promoting the use of alternative modes of transportation.

Caltrans has adopted procedures to oversee construction activities on and around its facilities. The Caltrans Construction Manual (Caltrans 2020a) describes best practices for construction activities, including personnel and equipment safety requirements, temporary traffic control, signage, and other requirements aimed at reducing construction-related hazards and constructing projects safely and efficiently. Any work proposed on Caltrans facilities would be required to abide by these requirements.

2.1.1.3 Office of Planning and Research: Vehicle Miles Traveled Traffic Impacts Under SB 743

Per the December 2018 Technical Advisory on Evaluating Transportation Impacts in the California Environmental Quality Act (CEQA), released by the Office of Planning and Research (OPR): SB 743, which was codified in Public Resources Code (PRC) Section 21099, required changes to the guidelines implementing CEQA (CEQA Guidelines) (California Code of Regulations, Title 14, Div. 6, Ch. 3, Section 15000 et seq.) regarding the analysis of transportation impacts. As one appellate court recently explained:

“During the last 10 years, the Legislature has charted a course of long-term sustainability based on denser infill development, reduced reliance on individual vehicles and improved mass transit, all with the goal of reducing greenhouse gas emissions. Section 21099 is part of that strategy...” (Covina Residents for Responsible Development v. City of Covina (2018) 21 Cal.App.5th 712, 729.)

Pursuant to Section 21099, the criteria for determining the significance of transportation impacts must “promote the reduction of greenhouse gas emissions, the development of multimodal transportation networks, and a diversity of land uses.” (Id., subd. (b)(1); see generally, adopted CEQA Guidelines, Section 15064.3, subd. (b) [Criteria for Analyzing Transportation Impacts].) To that end, in developing the criteria, OPR has proposed, and the California Natural Resources Agency (CNRA) has certified and adopted, changes to the CEQA Guidelines that identify Vehicle Miles Traveled (VMT) as the most appropriate metric to evaluate a project’s transportation impacts. With the CNRA’s certification and adoption of the changes to the CEQA Guidelines, automobile delay, as measured by *Level of Service (LOS)* and other similar metrics, no longer constitutes a significant environmental effect under CEQA. (PRC Section 21099, subd. (b)(3).)

Caltrans has also issued its own guidance for implementation of SB 743 for projects that could impact Caltrans facilities. Caltrans issued its Transportation Analysis Framework in September 2020, which details methodology for calculating induced demand for capacity increasing transportation projects on the State Highway System (Caltrans 2020b). Caltrans also issued its Transportation Analysis Under CEQA guidance in September 2020, which describes significance determinations for capacity increasing projects on the State Highway System.

Transportation facilities under the jurisdiction of Caltrans within the vicinity of the Project Site include Highway 78.

Due to the location of the Proposed Project and the nature of the Project being a remotely operated solar farm with minimal structural development that would not include additional full-time employees onsite, VMT impacts are not analyzed further in this document.

2.1.2 Local

2.1.2.1 Southern California Association of Governments Plans and Programs

The Southern California Association of Governments (SCAG) is responsible for the regional planning in Southern California, within the SCAG region of counties. SCAG has prepared long range growth and

development plans for the Southern California region since the early 1970s as part of the ongoing Development Guide Program. This program provides a framework for coordinating local and regional decisions regarding future development and growth. An important component of this process is the preparation of growth at intervals ranging from 3 to 5 years. The adopted growth forecast policies become the basis for SCAG's functional plans (i.e., transportation, housing, air and water) for the region. The population totals and growth distribution are used in planning the future capacity of highways and transit systems.

The Regional Comprehensive Plan (RCP) recommends ways to redirect the region's growth in order to minimize congestion and better protect the environment. While SCAG has no authority to mandate implementation of its RCP, some of the Plan's principal goals (i.e., improved jobs/housing balance) are being implemented through county and city general plans.

The Regional Transportation Plan (RTP), Destination 2030, is linked to the RCP. Because SCAG has authority over a significant amount of transportation funding, it also has some control over the implementation of transportation-related projects. The Goods Movement Action Plan seeks to optimize the region's transportation system through increases in economic efficiency, congestion, mitigation, safety and air quality improvements, and enhancements to system security. The Compass Blueprint 2-percent Strategy provides for studying new directions for growth.

2.1.2.2 Imperial County General Plan Circulation and Scenic Highways Element

The Imperial County General Plan CSHE is intended to provide a plan to accommodate a pattern of concentrated and coordinated growth, providing both, regional and local linkage systems between unique communities, and its neighboring metropolitan regions while protecting and enhancing scenic resources within both rural and urban scenic highway corridors. The Imperial County General Plan CSHE policies related to the proposed Project are outlined below. Table 1 summarizes the proposed Project's consistency with the applicable General Plan policies.

While this report analyzes the Proposed Project's consistency with the General Plan pursuant to CEQA Guidelines Section 15125(d), the Imperial County Planning Commissioners and Board of Supervisors ultimately determines consistency with the General Plan.

Table 1. Transportation and Circulation Standards of the Imperial County General Plan CSHE	
Plan/Policy	Standard/Criteria
CSHE Goal 1: The County will provide and require an integrated transportation system for the safe and efficient movement of people and goods within and through the County of Imperial with minimum disruption to the environment.	A qualitative analysis has been prepared which demonstrates that the proposed Project would not cause existing roadways or intersections to operate below a Level of Service "C". Traffic impacts were concluded to be less than significant. No mitigation is required.
CSHE Objective 1.2: Require a traffic analysis for any new development which may have a significant impact on County roads.	
CSHE Objective 1.12: Review new development proposals to ensure that the proposed development provides adequate parking and would not increase traffic on existing roadways and intersection to a level of service (LOS) worse than "C" without providing appropriate mitigations to existing infrastructure.	

2.1.2.3 County of Imperial Bicycle Master Plan

In 1999, the County of Imperial adopted a Bicycle Master Plan for use as a guideline in planning, developing, designing, and constructing future bicycle facilities. This was readopted in 2003. The County Bicycle Master Plan is periodically updated and approved by the County and Imperial Valley Association of Governments (IVAG). The most current approved Bicycle Master Plan is herein made a part of the Circulation Element as an appendix and said plan may be amended from time to time. The latest adopted version will constitute the appendix.

2.1.2.4 Imperial County Airport Land Use Compatibility Plan

The County of Imperial approved an amended Airport Land Use Compatibility Plan for all Imperial County airports in June 1996. The plan sets forth the criteria and policies that the Airport Land Use Commission use to assess the compatibility between the primary airports in the County and proposed land use development in the areas surrounding them. Airports affected by this plan located near El Centro are the Imperial County Airport and the Naval Air Facility at El Centro. Additionally, the Plan provides guidance for commission review of new airports and heliports proposed for construction in the County.

2.1.2.5 2002 Imperial County 20-Year Transportation Plan Update - Highway Element

The 2002 Transportation Plan is a 20-year plan that articulates Imperial County’s transportation challenges. The plan provides the foundation for future transportation funding decisions by establishing a set of transportation priorities for Imperial Valley roads and highways. These priorities are intended to meet and respond to the unique transportation characteristics of Imperial Valley’s residents, visitors, economy, and businesses. The basis for addressing the region’s particular needs was based on the mission

statement: "Maintain and improve mobility for people and goods to enhance the quality of life and economic vitality of Imperial County."

2.1.2.6 Imperial County 20-Year Transportation Plan – Non Motorized Transportation Element

An *Imperial County 20-Year Non-Motorized Transportation Plan* was prepared for the IVAG and released in April 2000. The study evaluates existing facilities for pedestrian and bicycles services in Imperial County and provides long-term recommendations. The plan includes specific recommendations based upon census data. The Non-Motorized Transportation Plan is prepared for the member agencies of the IVAG.

2.1.2.7 Imperial Valley Short Range Transit Plan

The Short Range Transit Plan (SRTP), at the time of this update, was published in 2003 and is an administrative and management tool. The SRTP is a federally mandated planning document that describes the plans, programs and goals of the transit operator. It has a 10-year planning horizon and is updated biennially. It focuses on the characteristics and capital needs of the existing system, and on committed (funded) expansion plans. The various regional County contracted transit services are listed, as well as the cities services. The plan is supported by the County circulation element goals and objectives. The SRTP is prepared for the member agencies of the IVAG.

2.1.2.8 Regional Transportation Plan, "Destination 2030"

The RTP is a multi-modal, long-range planning document prepared by the SCAG, in coordination with federal, state, IVAG, and other regional, sub regional and local agencies in Southern California.

The RTP includes programs and policies for congestion management, transit, bicycles and pedestrians, roadways, and finances. The RTP is prepared every 3 years and reflects the current future horizon based on a 20-year projection of needs.

The RTP's primary use is as a regional long-range plan for federally funded transportation projects. It also serves as a comprehensive, coordinated transportation plan for all governmental jurisdictions within the region.

Each agency responsible for transportation, such as local cities, the County, and Caltrans, has different transportation implementation responsibilities under the RTP. The RTP relies on the plans and policies governing circulation and transportation in each county to identify the region's future multi-modal transportation system.

2.1.2.9 Traffic Study and Report Policy

The *Imperial County Traffic Study and Report Policy* (Imperial County Public Works 2007) identifies standards of significance for appropriate traffic studies for applicable land use types in the region. The basic criteria that will be used to make the determination for providing a complete traffic study as a part

of the project review process are listed below. The criteria are not a complete or exhaustive list, but they are intended to define when such a report is to be prepared.

General Criteria

- A. Any project that adds more than 8 percent of the total existing vehicle trips on the adjacent road system at full build-out of the project.
- B. Any project that generated more than 400 daily residential trip ends, 800 commercial or industrial trip ends or 200 peak hour trip ends, as determined by the average trip rates contained in the ITE Trip Generation Informational Report or the Imperial County Local Exceptions.
- C. Any project that has the potential to degrade an existing road section, an existing signalized intersection, or an existing unsignalized intersection to below the existing level of service or to cause it to be lower than a level of service (LOS) "C" during any peak hour, using the HCM Methods of analysis on any individual, existing traffic movement.
- D. Any project, within criteria b. above, which generates more than 10% of its total traffic in the form of truck traffic.
- E. Any project that intensifies the usage of the site above the level currently allowed by zoning codes and requires a GPA; and/or CUP, zone change, variance or other discretionary permit.
- F. Any project that may cause an existing or proposed intersection to meet traffic signal warrants or cause a proposed intersection to be lower than LOS "C".

The Project does not meet any of the General Criteria listed above, so a full traffic study is not required.

3.0 ENVIRONMENTAL SETTING

Existing traffic conditions are the baseline from which potential Project impacts are measured. Existing traffic conditions are presented in terms of the roadway system network, traffic volumes, and current traffic operating conditions.

3.1 Existing Road Network

3.1.1 State Roadways

3.1.1.1 State Route 111 (Highway 111)

Highway 111 is classified as a State Highway/Expressway in the Imperial County General Plan CSHE. Highway 111 is a north-south highway connecting the three largest cities in Imperial County — Calexico, El Centro, and Brawley — and runs from Interstate 10 in Riverside County to the U.S./Mexico border. Outside the towns of Calipatria and Niland, Highway 111 is constructed as a two-lane undivided north-south roadway, providing one lane of travel per direction; and the posted speed limit is generally 65 mph.

3.1.1.2 State Route 115 (Highway 115)

Highway 115 is classified as a State Highway in the Imperial County General Plan CSHE. Highway 115 is primarily a northerly route serving as an alternate to SRs 86 and 111. For the most part, SR 115 is a two-lane conventional highway, although some short segments are four-lanes with a posted speed limit of 65 mph.

3.1.1.3 State Route 78 (Ben Hulse Highway)

State Route 78 is classified as a State Highway/Expressway in the Imperial County General Plan CSHE. SR 78 is an east-west route highway traversing approximately 82 miles through Imperial County. The route is a two-lane conventional highway throughout its alignment, although some portions have been upgraded to a four-lane expressway and four-lane conventional highway as a result of recent improvement projects. SR 78 is a two-lane conventional highway within the Project vicinity; the posted speed limit is generally 65 mph.

3.1.1.4 Transit, Bicycle and Pedestrian Facilities

Transit, bicycle, and pedestrian facilities are not available within 5 miles of the Project site.

3.1.1.5 Airports

The Calipatria Municipal Airport, located approximately 14-miles south of the Project site, is the nearest public airport.

3.2 Existing Traffic Volumes

Existing traffic volumes on Project vicinity roadways were promulgated from the Caltrans Traffic Census Program for roadway segments in the Project vicinity, which include SR 111, English Road, Niland Ave, Frink Road, Bombay Beach Road, and Beal Road. Traffic volumes for the listed roadway segments are provided in Table 2.

Table 2. Existing Traffic Volumes on Project Vicinity Roadways		
SR-111 Roadway Segment	Peak Hour Monthly Average Daily Trips	Annual Average Daily Traffic (AADT)
English	2,800	2,200
Niland	3,550	2,800
Frink	2,688*	2,113*
County Line	1,900	1,600
Bombay Beach	1,950	1,300
Beal	4,100	3,150

Source: Caltrans Traffic Census Program *Traffic Volumes: Annual Average Daily Traffic (AADT)* 2017.

* Estimated Traffic Volume, Average of 2017 Roadway Segment Data in Project Vicinity.

3.3 Level of Service Standards

A project’s effect on roadway capacity and LOS does not constitute a significant environmental impact under CEQA. However, a LOS evaluation is required per the County’s guidelines to determine if the project would cause any negative effects on roadway operations. The Imperial County Traffic Study and Report Policy, and the County’s General Plan Circulation and Scenic Highway Element require intersections and roadway segments to maintain a peak-hour LOS of C or better.

3.3.1 Intersection Level of Service Definitions

For this analysis, LOS is based on the *Highway Capacity Manual* (HCM) 6th edition (Transportation Research Board 2016) definitions, included as Table 3 for ease of reference. The HCM methodology assigns an LOS grade to an intersection based on the delay for vehicles at the intersection, ranging from LOS A to F; LOS A signifies very slight delay with no approach phase fully utilized, while LOS F signifies very high delays and congestion, frequent cycle failures, and long queues. For signalized and all-way stop-controlled intersections, the average control delay for all vehicles is assessed; for two-way stop-controlled intersections, the intersection approach with the highest delay is utilized. Table 3 shows the LOS thresholds from the HCM. For signalized intersections, LOS criteria are stated in terms of the average control delay (in seconds) per vehicle for a 15-minute analysis period. Control delays include initial deceleration delay, queue move-up time, stopped delay, and final acceleration delay. For unsignalized intersections, LOS is determined by the computed or measured control delay. It is defined for each movement through the intersection rather than for the intersection as a whole.

Level of Service (LOS)	Average Control Delay (Signalized) (sec/vehicle)	Average Control Delay (Unsignalized) (sec/vehicle)
A	≤ 10.0	≤ 10.0
B	10.0 to 20.0	10.1 to 15.0
C	20.0 to 35.0	15.1 to 25.0
D	35.1 to 55.0	25.1 to 35.0
E	55.1 to 80.0	35.1 to 50.0
F	≥ 80.1	≥ 50.0

Source: Kittleson & Associates 2022 (Appendix M).

3.3.2 Existing Roadway Segment Operations

The North Star 1 Project site is adjacent to Coachella Canal Road between English and Frink Road. Peak hour traffic on this segment is 310 vehicles, or approximately five vehicles per minute. The Project study area is located in a rural setting, and all intersections are unsignalized. All studied intersections currently operate at a Level of Service (LOS) “B” or better. Project-related traffic during construction and operation would not reduce the LOS in the Project Area to unacceptable levels.

3.3.3 Parking Facilities

Onsite parking would be provided for all construction workers for the duration of the construction period. Because the conceptual plans lack sufficient detail of site aisles and parking spaces, the design assessment is limited to a high-level basis. It is expected that there will be sufficient parking for all construction workers.

4.0 ENVIRONMENTAL CONSEQUENCES AND MITIGATION MEASURES

4.1 Significance Criteria

For this analysis, significance criteria are based on the checklist presented in Appendix G of the State CEQA Guidelines; factual information; scientific data; and regulatory standards of Federal, State, and local agencies.

4.2 CEQA Criteria

Based on Appendix G of the State CEQA Guidelines, an alternative would result in a significant impact on transportation and circulation if it would result in:

1. conflict with a program, plan, ordinance, or policy addressing the circulation system, including transit, roadways, bicycle and pedestrian facilities?
2. conflict or be inconsistent with CEQA Guidelines Section 15064.3, subdivision (b)?
3. substantially increase hazards due to a geometric design feature (e.g., sharp curves or dangerous intersections) or incompatible uses (e.g., farm equipment)?
4. result in inadequate emergency access?

4.3 Methods and Assumptions

The analysis prepared in this section is based on a Traffic Impact Report prepared by Kittelson & Associates (2022, Appendix M) and Caltrans Traffic Census Program (Traffic Volumes: Annual Average Daily Traffic 2017). As discussed above, under SB-743, a project's effect on automobile delay shall not constitute a significant environmental impact. Therefore, LOS metrics may no longer serve as transportation impact metrics for CEQA impact analyses. However, the County of Imperial Department of Public Works requires transportation analyses to review roadway capacity in terms of LOS to identify deficiencies and required improvements to the circulation system, outside of the CEQA analysis.

During the construction phase of the Project, the relative impact of implementing the Project has been determined by estimating the amount of traffic associated with construction activities within the Study Area and superimposing that traffic onto existing traffic volumes. The traffic volumes associated with regular post-Project activities are anticipated to be approximately equal to or slightly higher than existing traffic volumes due to maintenance of the facility. This increase in volume is unknown and is expected to be relatively minor in comparison to existing conditions; thus, a quantitative analysis of resulting traffic

operations under current and cumulative conditions is not recommended. A qualitative analysis is presented below in lieu of a quantitative analysis.

4.4 Trip Generation

4.4.1 Construction

The amount of automobile and truck traffic associated with implementation of the Project alternatives would vary throughout the construction season as different activities occur. To ensure that the magnitude of traffic impacts is not underestimated for this analysis, it assumes the maximum probable concurrent employment on the Project Site and maximum concurrent truck activity. It is estimated there will be a maximum of 160 worker commutes and 10 vendor trips daily to the Project Site during construction.

4.4.1.1 Worker Commutes

It has been assumed for this analysis that each construction worker would drive a personal vehicle to the construction site. In reality, it is likely that some employees within individual trade groups would informally carpool to the job site; as a result, this assumption yields a conservatively high estimate of site trip generation. It has also been assumed that on a given day, 100 percent of the construction employment would arrive at the Project site during the a.m. peak hour, and that 100 percent of the onsite construction employment departs during the p.m. peak hour. In reality, it is likely that some employees would arrive and depart during periods outside of peak commute hours. Thus, this analysis provides a conservatively high estimate of peak-hour construction employee traffic. In total, with a conservative estimate, there is a maximum of 160 worker commutes during construction.

4.4.1.2 Vendor Trips

Trucks would travel to and from the Study Area over the life of the construction phase. The amount of truck activity has been estimated based on a review of the Project design. In a conservative estimate, there is a maximum of 10 daily vendor trips during construction.

4.4.1.3 Regional Trip Distribution

It is necessary to identify the traffic routes that would be used for the Proposed Project, and the regional distribution of Project trips is an element in that process. It is assumed that the relative regional distribution of the Project's employee and construction truck traffic would be similar due to the few state highways in the vicinity of the Project that would funnel both workers and construction goods. Based on the regional orientation of Project and the street system within its vicinity, the Project site would only be accessible via Coachella Canal Road. The exact breakdown of travel on each route would vary from day to day, and a "composite" trip assignment reflecting the average use on each route over the duration of the Project has been employed for this analysis.

The assumptions made about employee and truck distribution are identified in Table 4. As noted, the primary route for truck traffic would be via Coachella Canal Road, which intersects SR-111 at Niland, Beal, and Cuff. SR-111 is the primary route for northbound traffic from Calipatria and nearby communities with

lodging. Southbound traffic bound from the Palm Springs area along SR-111 would utilize Frink Road for site access. All construction traffic would utilize Coachella Canal Road for access to the Project site.

Imported materials could come from either direction (e.g., Bombay Beach, Calipatria). Employee traffic would also likely be evenly distributed based on the location of nearby lodging.

Table 4. Project Trip Distribution			
Direction	Route	Percentage of Total Traffic	
		Trucks	Employees
Northbound	SR-111 to English/Niland Road	5	80
Southbound	SR-111 to Frink Road	5	80
Total:		10	160

Source: Data estimated based on geographic location of commuters and vendors.

Due to the location of the Project site and its associated local roadways, vendor truck traffic could approach the facility from either direction via Coachella Canal Road.

4.4.1.4 Staging and Parking

Due to lack of specificity in the Project design, the staging areas during construction have not been estimated for this analysis. The primary staging and parking area is anticipated to be within the Project boundary and to remain until the construction period ends.

4.4.2 Operation

Due to the Project being remotely operated and the fact that it will not require full-time onsite employees, it is estimated that operational construction will be minimal and will be approximately the same as current conditions. Similar to the construction analysis, the operation analysis assumes the maximum probable operational trips to the Project site. It is estimated there will be a maximum of four heavy duty trucks daily to the Project Site during operation.

4.4.2.1 Parking Demand

Due to the low number of daily trips to the Project Site during operation, it is anticipated there will be a small parking area for when employees must travel to the Project Site. It is anticipated the operational parking area will be on the same footprint as the construction staging and parking area.

4.4.2.2 Long-term Traffic Volumes

Due to the nature of Project construction being temporary and operational traffic being minimal, long-term increases in traffic would be negligible and a future conditions traffic analysis following construction is not warranted.

4.5 Impacts Not Discussed Further

VMT impacts are not analyzed further in this document due to the location of the Proposed Project and the nature of the Project being a remotely operated solar farm with minimal structural development that would not include additional full-time employees onsite.

4.5.1 Impact Analysis and Mitigation Measures

- IMPACT 1 Conflict with Adopted Policies, Plans, or Programs Regarding Public Transit, Bicycle, or Pedestrian Facilities.** *The Proposed Project would not include any project actions within roadway segments. Additionally, the Proposed Project is not in the vicinity of a Public Transit route, or Bicycle or Pedestrian Facilities. Therefore, the Proposed Project would not conflict with any programs, plans, ordinances, or policies addressing the circulation system, including transit, roadways, bicycle, and pedestrian facilities. Therefore, no impact would occur, and no mitigation is required.*
- IMPACT 2 Result in a substantial Increase in Traffic Volume (VMT or LOS) – Existing Plus Project by conflicting or being inconsistent with CEQA Guidelines Section 15064.3, subdivision (b).** *There would be no change in traffic volumes associated with Project construction or operation as project construction is temporary and project operation would have no full-time on-site employees. A VMT analysis is not required for this impact. This impact would be less than significant, and no mitigation would be required.*
- IMPACT 3 Result in a substantial increase in roadway or traffic hazards due to a geometric design feature (e.g., sharp curves or dangerous intersections) or incompatible uses (e.g., farm equipment)?** *The average daily trips during construction and operation would be minimal along the State Highways. The intersections at both SR-111 and English/Niland Road and SR-111 and Frink Road are railroad crossings. There is a potential for Truck Traffic approaching the Project site along SR-111 to impede the flow of traffic while waiting at either crossing. However, these effects would be temporary and minor for the duration of construction, and no long-term effects on geometric design features on Project Vicinity roadways would occur that could result in an increase in hazards. This impact would be less than significant, and no mitigation would be required.*
- IMPACT 4 Result in inadequate emergency access.** *There is a potential for truck traffic when approaching the Project site along Coachella Canal Road. However, these effects would be temporary and minor, and no long-term effects on emergency access would occur that could result in an increase in hazards. This impact would be less than significant, and no mitigation would be required.*

5.0 REFERENCES

- California Department of Transportation (Caltrans). 2020a. *Caltrans Construction Manual*. Available online at: <https://dot.ca.gov/programs/construction/construction-manual>.
- _____. 2020b. Transportation Analysis Framework. Available online at: https://dot.ca.gov/-/media/dot-media/programs/sustainability/documents/2020_09_10_1st_edition_taf_fnl_a11y.pdf.
- _____. 2017. Traffic Census Program. (Traffic Volumes: Annual Average Daily Traffic 2017). Available online at: <https://dot.ca.gov/programs/traffic-operations/census>.
- Imperial County. 2008. *Circulation and Scenic Highways Element*. Approved by: Board of Supervisors January 29, 2008. Available at: [http://www.icpds.com/CMS/Media/Circulation-Scenic-Highway-Element-\(2008\).pdf](http://www.icpds.com/CMS/Media/Circulation-Scenic-Highway-Element-(2008).pdf).
- Imperial County Public Works. 2007. *Imperial County Traffic Study and Report Policy*. Adopted August 7, 2007. Available online at: <https://publicworks.imperialcounty.org/wp-content/uploads/2019/12/TrafficStudyReportPolicy.pdf>.
- Kittelson & Associates, 2022. *Vikings Solar Energy Storage Project Transportation Study*. Prepared for Vikings Energy Farm, LLC. January 12 (Appendix M).
- Transportation Research Board. 2016. *Highway Capacity Manual 6th Edition*. Available online at: <https://www.trb.org/Main/Blurbs/175169.aspx>.

**Water Supply Assessment
For the ZGlobal
North Star 1, LLC
Solar Energy Project
Imperial County, California**

Prepared for:

ECORP Consulting, Inc.
2525 Warren Drive
Rocklin, CA 95677

Prepared by:

Dr. Andrew A. Kopania
California Professional Geologist No. 4711
California Certified Hydrogeologist No. HG31
EMKO Environmental, Inc.
551 Lakecrest Drive
El Dorado Hills, California 95762

March 12, 2023

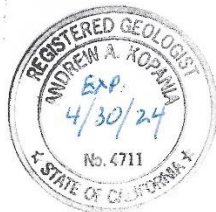

Water Supply Assessment For the ZGlobal North Star 1, LLC Solar Energy Project Imperial County, California

Table of Contents

1.0	INTRODUCTION	1
2.0	PROJECT DESCRIPTION	1
3.0	WATER SUPPLY PLANNING UNDER SB 610 and SB 1262	6
3.1	Is the Proposed Project Subject to CEQA?	6
3.2	Is the Proposed Project a “Project” Under SB 610?	7
3.3	Is There a Public Water System That Will Service the Proposed Project?	7
3.4	Is There a Current Urban Water Management Plan That Accounts for the Project Demand?	7
3.5	Is Groundwater a Component of the Supplies for the Project?	8
3.6	Are There Sufficient Supplies to Serve the Project Over the Next Twenty Years?	9
4.0	PROJECT WATER SUPPLY	10
4.1	Groundwater Basin	10
4.2	Groundwater Supply and Recharge	12
4.3	Groundwater Sustainability	14
5.0	PROJECT WATER DEMAND	15
6.0	DRY YEAR SUPPLY	15
7.0	FINDINGS and DISCUSSION	17
8.0	DOCUMENTS CONSIDERED AND REFERENCES CITED	19

LIST OF TABLES

- 1 USGS Water Quality Data (June 13, 1963)
- 2 Project Water Demand

LIST OF FIGURES

- 1 Regional Location Map
- 2 Project Location
- 3 Site Plan
- 4 East Salton Sea Groundwater Basin
- 5 USGS Groundwater Level Hydrograph
- 6 Water Year Rainfall at Niland

Water Supply Assessment For the ZGlobal North Star 1, LLC Solar Energy Project Imperial County, California

1.0 INTRODUCTION

EMKO Environmental, Inc. (EMKO) has prepared this Water Supply Assessment (WSA) as a subconsultant to ECORP Consulting, Inc. for the proposed ZGlobal North Star 1, LLC Solar Energy Project (Project) in Imperial County, California at the location indicated on Figure 1. Project water use includes dust control and soil conditioning requirements during construction and routine maintenance, primarily panel washing, during operation.

Water Code Sections 10910 through 10915 were amended by Senate Bill 610 (SB 610) in 2002. SB 610 requires that under specific circumstances, as detailed below, an assessment of available water supplies must be conducted. The purpose of the assessment is to determine if available water supplies are sufficient to serve the demand generated by the Project, as well as the reasonably foreseeable demand in the region over the next 20 years under average normal year, single dry year, and multiple dry year conditions. Water Code Section 10910 was further amended by SB 1262 on September 24, 2016 to require a Water Supply Assessment to include additional information regarding the groundwater basin designation and adjacent water systems. This report provides the information required for a Water Supply Assessment (WSA), as described in the October 2003 *Guidebook for Implementation of Senate Bill 610 and Senate Bill 221 of 2001 to Assist Water Suppliers, Cities, and Counties in Integrating Water and Land Use Planning*, published by the California Department of Water Resources (DWR Guidebook) along with the additional information required by SB 1262.

2.0 PROJECT DESCRIPTION

North Star 1, LLC is proposing to construct and operate solar energy generation and storage facilities on private lands in the Imperial Valley in Imperial County. The Project site is located approximately eight miles east of the community of Bombay Beach and six miles north of the community of Niland (see Figure 1).

The Project would cover approximately 287 acres in Section 1 of Township 10 South, Range 13 East of the San Bernardino Base and Meridian (SBB&M) within the “Wister” 7.5-minute U.S. Geologic Survey (USGS) quadrangle. The Project site includes all or part of Imperial County Assessor’s Parcel Numbers (APNs) 003-110-005 (approximately

111 acres) and APN 003-110-007 (approximately 176 acres). The East Highline Canal is located near the southwest side of APN 003-110-005 (see Figure 2). The Project includes a 50-megawatt solar photovoltaic system and integrated 75-megawatt battery energy storage system along with related substations and transmission lines. The Project water supply will be provided by a new well or wells to be drilled onsite. Figure 3 is a Site Plan showing the Project layout and ancillary facilities.

The parcels are not currently located within the Imperial County Renewable Energy Overlay Zone. Thus, an amendment to the County's General Plan must be approved, along with a Conditional Use Permit (CUP), to allow construction and operation of the Project. These are discretionary actions by the County requiring compliance with the California Environmental Quality Act (CEQA). This Water Supply Assessment is intended to support and be a part of the CEQA analysis.

Domestic water and sanitation facilities would be required during construction. These would be provided through bottled water and portable facilities. A domestic/potable water connection would not be required.

Construction is anticipated to require 12 months to complete. Anticipated operational Project life is 25 to 30 years.

Figure 1. Regional Location Map



Figure 2. Project Location



Figure 3. Site Plan

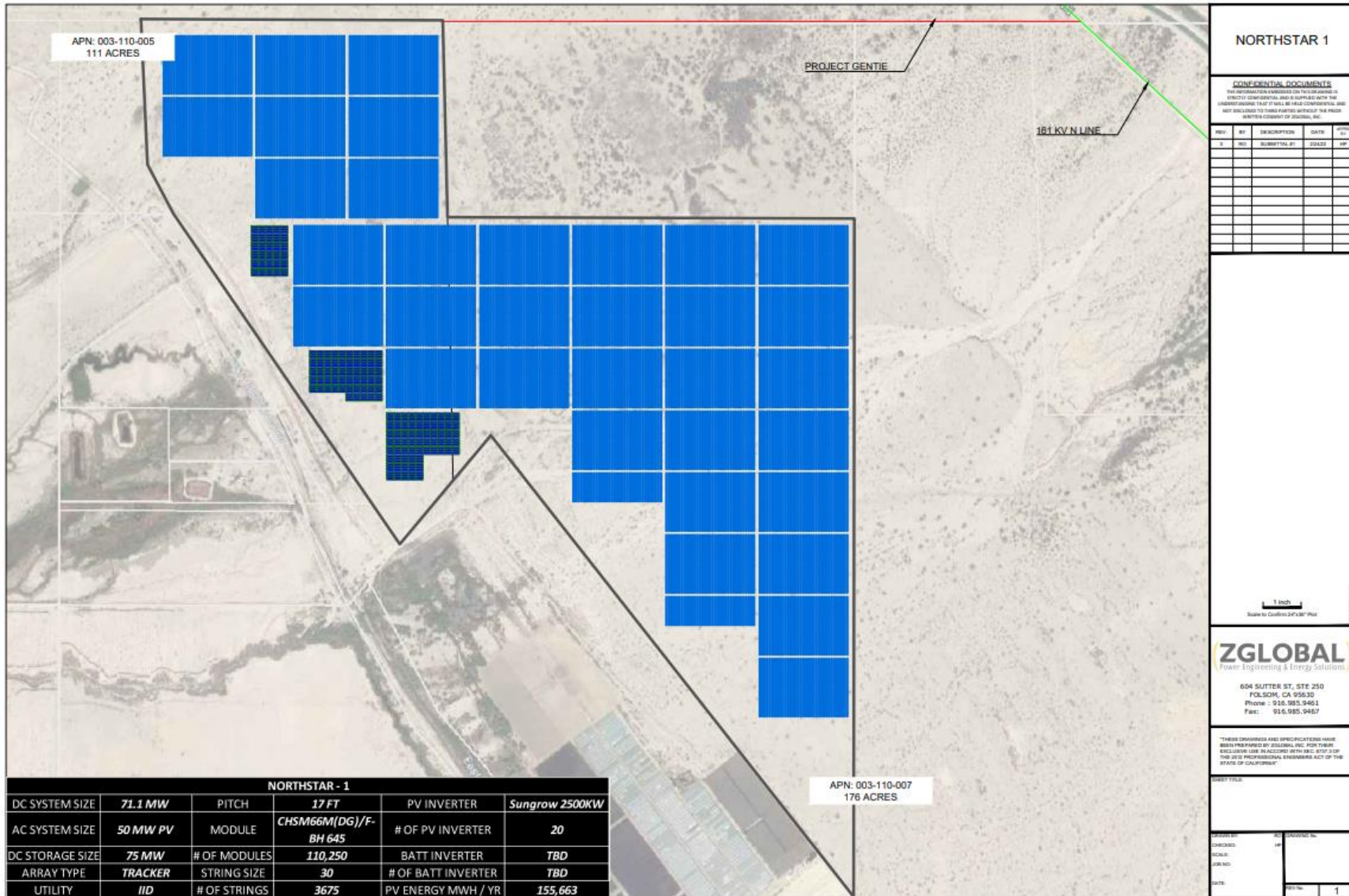

3.0 WATER SUPPLY PLANNING UNDER SB 610 and SB 1262

SB 610, effective January 1, 2002, amends Sections 10910 through 10915 of the Water Code by requiring preparation of a WSA for development projects subject to CEQA and other criteria, as discussed below. SB 610 also amends Section 10631 of the Water Code, which relates to Urban Water Management Plans (UWMPs). The WSA process under SB 610 is designed to rely on the information typically contained in UWMPs, where available.

On September 24, 2016, SB 1262 further amended Section 10910 of the Water Code to require additional information related to adjacent public water systems and the status of the groundwater basin. These amendments provide additional consistency with the Sustainable Groundwater Management Act of 2014, as discussed further in Section 4.4.

The first steps in the WSA process are to determine whether SB 610 applies to the proposed Project. If so, then documentation of available water supplies, anticipated Project demand, and the sufficiency of supplies must be conducted. These issues are summarized by the following questions, as outlined in the DWR Guidebook:

1. Is the proposed Project subject to CEQA?
2. Is the proposed Project a “Project” under SB 610?
3. Is there a public water system that will service the proposed Project?
4. Is there a current UWMP that accounts for the project demand?
5. Is groundwater a component of the supplies for the Project?
6. Are there sufficient supplies to serve the Project over the next twenty years?

Each of these issues are discussed in the following sections as they relate to the proposed Project.

3.1 *Is the Proposed Project Subject to CEQA?*

The first step in the SB 610 process is to determine whether the proposed project is subject to CEQA. Water Code Section 10910(a) states that any city or county that determines that an application meets the definition of “project”, per Water Code Section 10912 (see Section 3.2, below), and is subject to CEQA, shall prepare a water supply assessment for the project. CEQA applies to projects requiring issuance of a discretionary permit by a public agency, projects undertaken by a public agency, or projects funded by a public agency. As noted in Section 2.0, the proposed Project requires discretionary approval of a General Plan Amendment and a CUP by Imperial County, a public agency. Therefore, the Project is subject to CEQA. This WSA has been prepared to support the environmental review that will be conducted by Imperial County under CEQA.

3.2 Is the Proposed Project a “Project” Under SB 610?

The second step in the SB 610 process is to determine if the proposed Project meets the definition of “project” under Water Code Section 10912(a). Under Section 10912(a) a “project” is defined as meeting any of the following criteria:

1. a proposed residential development of more than 500 dwelling units;
2. a proposed shopping center or business establishment employing more than 1,000 persons or having more than 500,000 square feet of floor space;
3. a proposed commercial office building employing more than 1,000 persons or having more than 250,000 square feet of floor space;
4. a proposed hotel or motel, or both, having more than 500 rooms;
5. a proposed industrial, manufacturing, or processing plant, or industrial park planned to house more than 1,000 persons, occupying more than 40 acres of land, or having more than 650,000 square feet of floor area;
6. a mixed-use project that includes one or more of the projects defined above; or
7. a project that would demand an amount of water equivalent to, or greater than, the amount of water required by a 500 dwelling unit project.

The Project encompasses 287 acres. As a result, the Project will include an industrial site that is larger than 40 acres and thus this WSA is being prepared in accordance with criterion 5, above.

3.3 Is There a Public Water System That Will Service the Proposed Project?

Section 10912(c) of the Water Code identifies a public water system as a system for the provision of piped water to the public for human consumption that has 3,000 or more service connections. The Project site is approximately eight miles east of the community of Bombay Beach and six miles north of the community of Niland. APN 003-110-007 and most of APN 003-011-005 are located outside of Imperial Irrigation District’s (IID’s) Imperial Unit, meaning that they are outside of IID’s water service area (IID, 2023). The southwestern part of APN 003-011-005 may be located within the Imperial Unit, but does not currently have water service from IID (IID, 2023). Thus, there are no public water systems that will serve the Project. The water supply will be provided by a new onsite groundwater supply well or wells to be drilled and installed as part of the Project.

3.4 Is There a Current Urban Water Management Plan That Accounts for the Project Demand?

The Water Code requires that all public water systems providing water for municipal purposes to more than 3,000 customers, or supplying more than 3,000 acre-feet per year,

must prepare an UWMP. The DWR Guidebook (page iii) states that SB 610 repeatedly refers to the UWMP as a planning document that can be used to meet the standards set forth in the statute, and that UWMPs act as a foundation to fulfill the requirements of the statute. As noted in Section 3.3, above, there are no public water systems that will serve the Project and, therefore, there is not an UWMP that addresses the Project area or Project demand. Since there is not an UWMP that accounts for the Project demand, this WSA is based upon available and relevant information from DWR, the USGS, and other publicly available data. As this WSA has been prepared for use by the CEQA lead agency, this document includes an evaluation of whether the total projected water supplies, determined to be available during normal, single dry, and multiple dry water years during a 20-year projection, will meet the projected water demand associated with the proposed Project, in addition to existing and planned future uses, including agricultural and manufacturing uses, in accordance with Water Code § 10910(c)(4).

3.5 Is Groundwater a Component of the Supplies for the Project?

Water Code Section 10910(f), paragraphs 1 through 5, must be addressed if groundwater is a source of supply for the proposed Project. As described in Section 3.3, the water supply will be provided by a new groundwater supply well or wells that will be drilled and installed as part of the Project. Therefore, an assessment of groundwater conditions is included in this document.

Water Code Section 10910(f) paragraphs 1 through 5, as modified by SB 1262, state:

(f) If a water supply for a proposed project includes groundwater, the following additional information shall be included in the water supply assessment:

- (1) A review of any information contained in the urban water management plan relevant to the identified water supply for the proposed project.
- (2) (A) A description of any groundwater basin or basins from which the proposed project will be supplied. (B) For those basins for which a court or the board has adjudicated the rights to pump groundwater, a copy of the order or decree adopted by the court or the board and a description of the amount of groundwater the public water system, or the city or county if either is required to comply with this part pursuant to subdivision (b), has the legal right to pump under the order or decree. (C) For a basin that has not been adjudicated that is a basin designated as high- or medium priority pursuant to Section 10722.4, information regarding the following: (i) Whether the department has identified the basin as being subject to critical conditions of overdraft pursuant to Section 12924; and (ii) If a groundwater sustainability agency has adopted a groundwater sustainability plan or has an approved alternative, a copy of that alternative or plan. (D) For a basin that has not been adjudicated that is a basin designated as low- or very-low priority pursuant to Section 10722.4, information as to whether the department has identified the basin or basins as overdrafted or has projected

that the basin will become overdrafted if present management conditions continue, in the most current bulletin of the department that characterizes the condition of the groundwater basin, and a detailed description by the public water system, or the city or county if either is required to comply with this part pursuant to subdivision (b), of the efforts being undertaken in the basin or basins to eliminate the long-term overdraft condition.

(3) A detailed description and analysis of the amount and location of groundwater pumped by the public water system, or the city or county if either is required to comply with this part pursuant to subdivision (b), for the past five years from any groundwater basin from which the proposed project will be supplied. The description and analysis shall be based on information that is reasonably available, including, but not limited to, historic use records.

(4) A detailed description and analysis of the amount and location of groundwater that is projected to be pumped by the public water system, or the city or county if either is required to comply with this part pursuant to subdivision (b), from any basin from which the proposed project will be supplied. The description and analysis shall be based on information that is reasonably available, including, but not limited to, historic use records.

(5) An analysis of the sufficiency of the groundwater from the basin or basins from which the proposed project will be supplied to meet the projected water demand associated with the proposed project. A water assessment shall not be required to include the information required by this paragraph if the public water system determines, as part of the review required by paragraph (1), that the sufficiency of groundwater necessary to meet the initial and projected water demand associated with the project was addressed in the description and analysis required by paragraph (4) of subdivision (b) of Section 10631.

Paragraphs 1 through 4, above, are addressed in Section 4.0, below, including a description of the groundwater basin, groundwater conditions, and available supply. Section 5.0 presents available information regarding water demand for the Project.

The Paragraph 5 requirement to provide an analysis of the sufficiency of the groundwater basin to meet the projected water demand associated with the proposed project is addressed in Section 6.0, below.

3.6 Are There Sufficient Supplies to Serve the Project Over the Next Twenty Years?

Water Code Section 10910(c)(4) requires the WSA to “*include a discussion with regard to whether the total projected water supplies, determined to be available by the city or county for the project during normal, single dry, and multiple dry water years during a 20-year projection, will meet the projected water demand associated with the proposed project, in addition to existing and future planned uses, including agricultural and manufacturing uses.*”

The sufficiency of water supply for the proposed Project is addressed in Sections 6.0 and 7.0, below.

4.0 PROJECT WATER SUPPLY

As stated in Section 3.3, above, construction and operational water will be provided by a new onsite groundwater well or wells to be drilled as part of the Project. As such, groundwater will be the sole water supply for non-potable water needs. Because there are no public water systems or other significant users of groundwater in the groundwater basin, there are no Urban Water Management Plans or other planning documents that can be relied upon for this WSA. Thus, limited information is available regarding groundwater conditions in the Project vicinity.

Overall conditions within the groundwater basin are described in Section 4.1. Groundwater recharge and available supply are discussed in Section 4.2. Groundwater level trends and the status of the basin relative to the Sustainable Groundwater Management Act of 2014 (SGMA) is provided in Section 4.3, as required by SB 1262.

4.1 Groundwater Basin

The Project is located within the East Salton Sea Groundwater Basin, designated as basin number 7-033, as defined by DWR (2022a) (see Figure 4). The Basin is bounded on the northeast by the Chocolate Mountains and on the southwest by the San Andreas and Banning Mission Creek fault zones (DWR, 2003). DWR (2003) reports that these faults zones may act as barriers to groundwater movement between basins. The northwest and southeast edges of the groundwater basin are approximately defined by transitions between major surface drainages coming off of the Chocolate Mountains. The groundwater basin has an area of approximately 196,000 acres, or 306 square miles (DWR, 2003). The Basin has not been adjudicated (DWR, 2022b). Figure 4 shows the groundwater basin boundary and the approximate location of the Project.

Groundwater occurs within unconsolidated to semi-consolidated coarse sediment eroded from the Chocolate Mountains (DWR, 2003). The sediment generally occurs within large alluvial fans that originate at drainages and canyons within the bedrock formations in the mountains and spread out as they decrease in elevation toward the floor of the Imperial Valley or the Salton Sea. The alluvial fan sediments range in age from Tertiary to Quaternary. DWR (2003) reports that the alluvium is at least 400 feet thick.

FIGURE 4. East Salton Sea Groundwater Basin

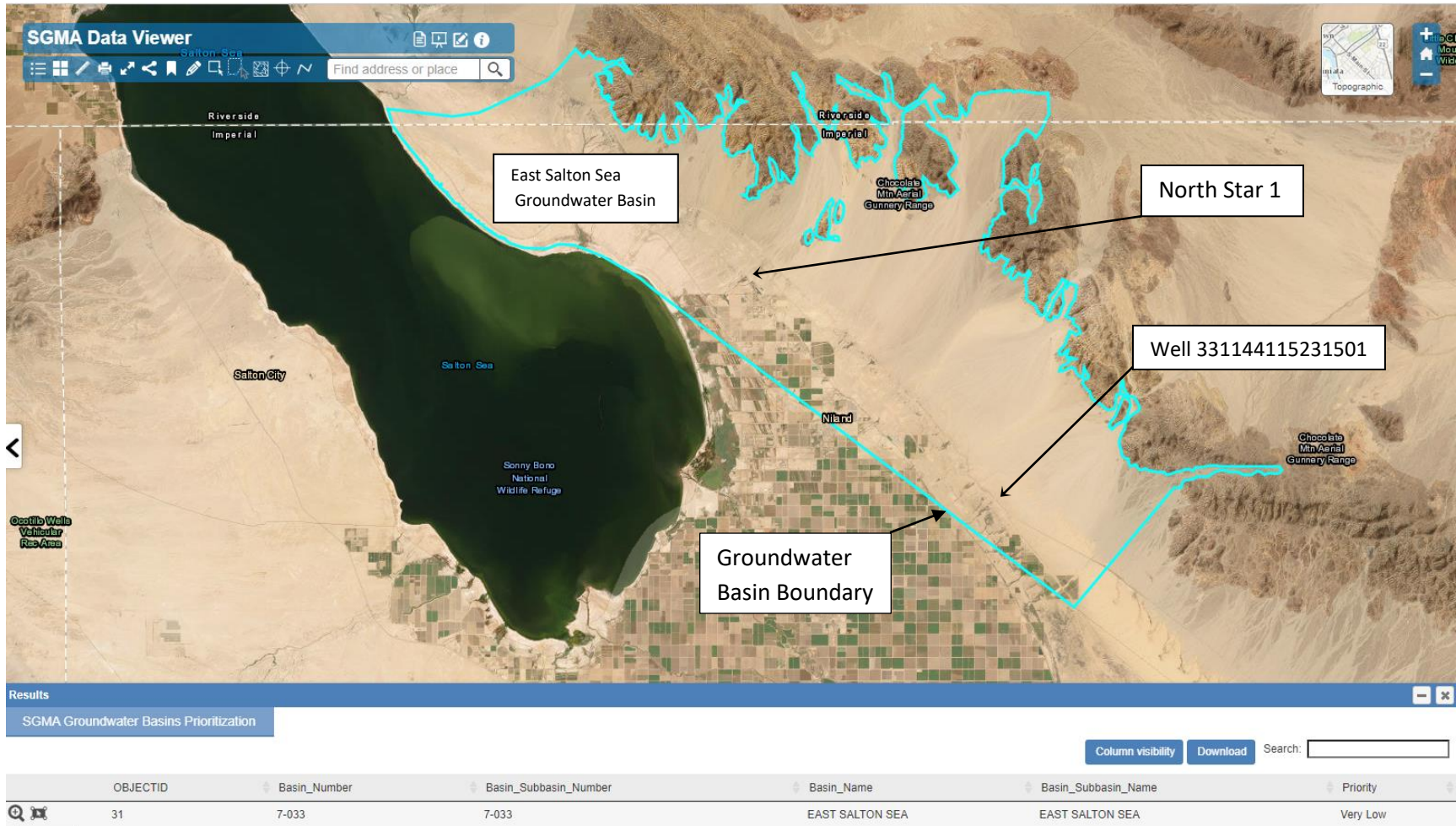

4.2 Groundwater Supply and Recharge

DWR (2022c) reports that the population in the Basin in 2010 was approximately 1,093 persons and that the population is expected to decrease 10 percent by 2030. There are no public water supply wells in the Basin and 11 total wells present. Only 4,906 acres of the 196,000-acre Basin, or 2.54 percent, are irrigated (DWR, 2022c). The total groundwater storage capacity of the groundwater basin is estimated to be 360,000 acre-feet (DWR, 2003).

The average annual rainfall is very low, as discussed further in Section 6.0 below, and typically does not provide a sufficient quantity of moisture to percolate deep into the alluvial sediments. As a result, recharge of groundwater occurs primarily due to runoff from the Chocolate Mountains during major storm events, which may not occur every year. The average annual recharge is estimated to be 200 acre-feet per year (DWR, 2003). That estimate is from a 1975 version of DWR Bulletin 118. However, no changes to basin conditions are reported in the most recent updates to DWR Bulletin 118 (DWR, 2021 and 2022a).

The USGS's National Water Information System mapping application (<https://maps.waterdata.usgs.gov/mapper/index.html>) show only one active groundwater monitoring location within the Basin at the time this report was prepared. That well is located approximately 13.5 miles southeast of the southeast corner of the Project site and 950 feet northeast of the Coachella Canal, as indicated on Figures 1 and 4. The well has USGS identification number 331144115231501, which identifies the latitude and longitude of the well (i.e., 33°11'44" latitude, -115°23'15" longitude), and California state well number 011S015E23M001, which indicates the township, range, and quarter-quarter section (i.e., northwest quarter or the southwest quarter of township 11S, range 15E, San Bernardino Base and Meridian). The ground surface elevation at the well location is reported to be 120 feet above mean sea level (ft msl) while the borehole in which the well was installed is reported to have been drilled to a depth of 550 feet below ground surface (ft bgs) (USGS, 2023a).

Figure 5 is a hydrograph from USGS (2022) showing the groundwater level and groundwater elevation measured since 1963 in Well 331144115231501, the sole active monitoring well in the Basin. As indicated on Figure 5, the groundwater level decreased at a relatively rapid rate from 1979 to approximately 2000, with the depth to water dropping from approximately 21 ft bgs to approximately 47 ft bgs over that period. Since 2000, the groundwater level has continued to decrease, but at a slower rate, with the level in March 2020 (the last date with a reported measurement by USGS) being approximately 50 ft bgs. While the groundwater level has decreased by almost 30 feet since 1979, it has changed by less than one foot over the past decade. Based on the depth to groundwater and the borehole depth for the monitoring well, the potential loss

of aquifer volume since 1979 is only six percent of the total available storage reported by DWR (2003).

FIGURE 5. USGS Groundwater Level Hydrograph

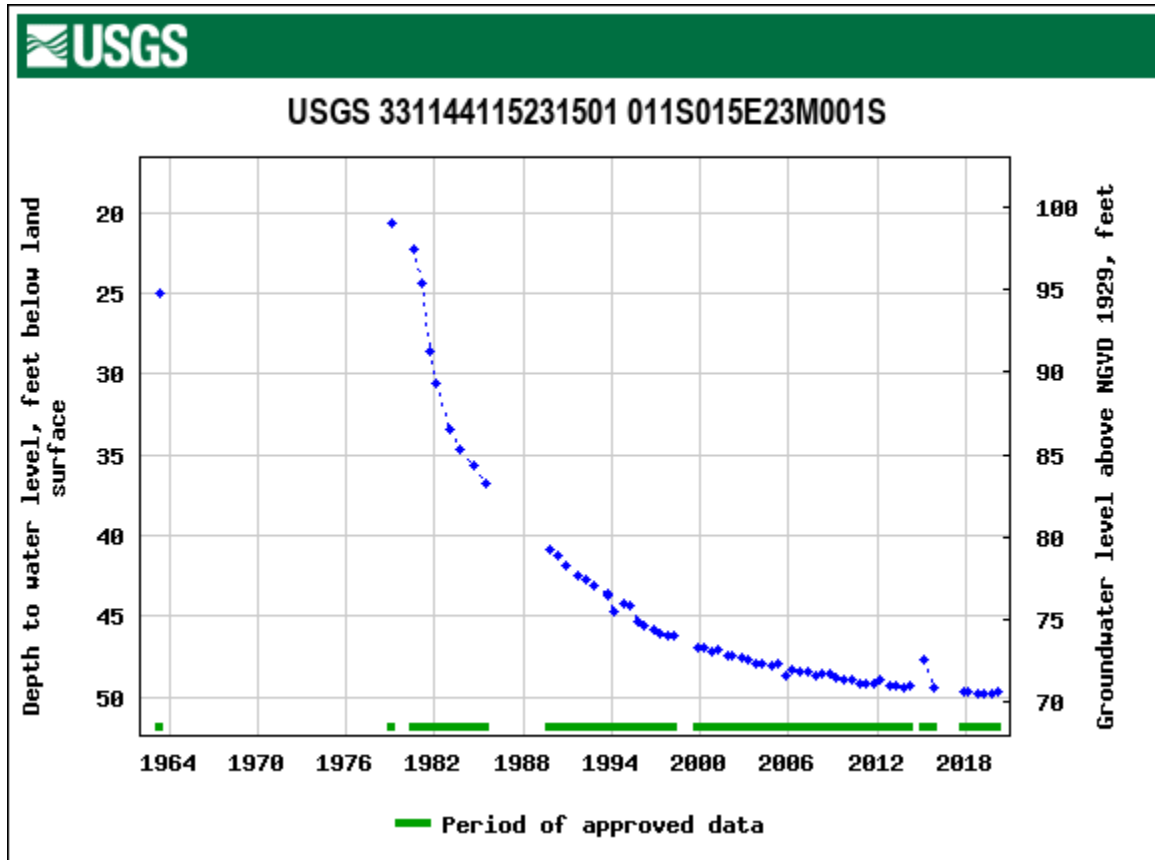

Water quality samples were collected and analyzed from Well 331144115231501 in June and September 1963 (USGS, 2023b). Table 1 shows the water quality results from June 1963. The September results were comparable. The groundwater has a normal pH but the levels of sodium, chloride, and sulfate are elevated compared to what would be expected from percolation of local rainfall. The dissolved solids concentration of 2,190 milligrams per liter (mg/L) is more than twice the value of the high end of the range of the secondary maximum contaminant level (MCL) for drinking water of 1,000 mg/L. The high dissolved solids concentration renders the water unsuitable for potable or agricultural uses without treatment. The existing water quality is suitable for use for construction and maintenance purposes, though.

Parameter	Units	Result
Temperature	Degrees Celsius (° C)	26.9
Specific Conductance	MicroSiemens per centimeter at 25° C	3630
pH	Standard units	7.4
Carbon Dioxide	Milligrams per liter (mg/L)	14
Acid Neutralizing Capacity	mg/L as calcium carbonate (CaCO ₃)	174
Bicarbonate	mg/L	212
Carbonate	mg/L	0.0
Hardness	mg/L as CaCO ₃	700
Non-carbonate hardness	mg/L as CaCO ₃	530
Calcium	mg/L	106
Magnesium	mg/L	107
Sodium + Potassium	mg/L	500
Chloride	mg/L	635
Sulfate	mg/L	700
Fluoride	mg/L	1.6
Silica	mg/L as silica dioxide (SiO ₂)	33
Dissolved Solids	mg/L	2190

Source: USGS, 2023b

4.3 Groundwater Sustainability

A series of three bills passed by the California legislature and were signed by Governor Brown on September 16, 2014. These three bills, Assembly Bill (AB) 1739, SB 1168, and SB 1319, together comprise the Sustainable Groundwater Management Act of 2014 (SGMA). SGMA provides a structure under which local agencies are to develop a sustainable groundwater management program. SGMA focuses on basins or subbasins designated by DWR as high or medium priority basins, and those with critical conditions of overdraft.

According to DWR (2022b), the East Salton Sea Groundwater Basin is very low priority basins. DWR has not identified the Basin as being overdrafted nor has it projected that it will become overdrafted if present management conditions continue (DWR, 2021 and 2022c). Thus, the Basin is not subject to the current requirements of SGMA, including the formation of a groundwater sustainability agency (GSA) and preparation of a groundwater sustainability plan (GSP).

5.0 PROJECT WATER DEMAND

Water demand varies depending on the Project phase. During construction, water will be needed for dust control and soil conditioning during installation of the photovoltaic panels, battery storage units, and related infrastructure. During the operational phase of the project, water will be needed for routine maintenance activities, which primarily consists of washing the photovoltaic panels to maintain generation efficiency.

Table 2 provides a summary of Project parameters that affect water demand and the estimated water needs for construction and operation. The construction water demand is primarily for dust control. Thus, the water needs are proportional to the size of the disturbed area and the local climate. Construction water demand is approximately 145 acre-feet. Construction is anticipated to require 12 months to complete. Thus, the monthly water demand during that period will average about 12 acre-feet.

Site	Area (acres)	Output (megawatts)	Construction Water (acre-feet)	Operational Water (acre-feet per year)
North Star 1	287	50	145	5

The operational water demand for panel washing and other maintenance needs is based primarily on the number of panels, which relates to the energy production or output, in megawatts. The operational water demand is anticipated to be 5 acre-feet per year. The maintenance activities are anticipated to be conducted up to twice a year over a one-to-two-week period each event, so the maintenance water demand is intermittent and not spread throughout the year. The operational water demand will occur throughout the life of the Project.

6.0 DRY YEAR SUPPLY

The volume and sustainability of dry-year water supply for a Project in California is typically addressed by comparing annual rainfall with changes in groundwater levels in the Basin. This comparison is made for a normal or average water year¹, for single dry year, and for multiple dry water years. For this Project, local rainfall data were obtained

¹ In California, a water year is defined as the period from October 1 of a calendar year through September 30 of the subsequent calendar year. A water year is designated by the year in which it ends. For example, the period from October 1, 2006 through September 30, 2007 is referred to as the 2007 water year. Due to the nature of weather patterns in the state, a water year better represents hydrologic conditions related to wet and dry periods than does a calendar year.

from the Western Region Climate Center (WRCC, 2022) for Niland, California, located approximately six miles south of the Project location (see Figure 1).

Figure 6 shows the annual water year rainfall for Niland, California from 1943 through 2017. Note that from 2006 through 2010, insufficient monthly measurements were made to identify the full water-year rainfall. The average water year rainfall at Niland during the period measured is 2.58 inches. The driest year was 1956, when no precipitation was recorded. The driest year during the period of available groundwater elevation data (see Figure 5) was 1996, with only 0.2 inch of rainfall reported. The wettest year was 1983, when 8.23 inches of rain was measured. As indicated on Figure 6, a relatively wet period occurred from 1976 to 1986, with 10 of 11 water years exceeding the average annual rainfall. In comparison, the period from 1996 to 2016 was relatively dry, with 18 of 21 water years having below normal rainfall.

The historic rainfall data on Figure 6 can be compared with the groundwater levels shown on Figure 5 to assess the effects of wet and dry periods on groundwater supply in the Basin. The wettest year recorded, 1983, and the relatively wet period from 1976 to 1986, correspond to a period when groundwater levels were dropping rapidly. In contrast, the dry period from 1996 to 2016 corresponds to a period when the rate of decline of the groundwater elevation was attenuating rapidly and beginning to stabilize. Thus, the available groundwater level and rainfall data do not indicate any relationship between wet, normal, single dry year, or multiple dry years and available groundwater supply. As noted above in Section 4.2, recharge of groundwater occurs primarily due to runoff from the mountains during individual major storm events (DWR, 2003). Such storm events typically occur infrequently and there may be many years between events that produce enough runoff to provide appreciable recharge.

The total groundwater storage capacity of the Basin is estimated to be 360,000 acre-feet (DWR, 2003) and the groundwater level decline from 1979 to 2018 decreased groundwater storage by approximately six percent (see Section 4.2). Thus, the current storage in the Basin may be in the range of 335,000 to 340,000 acre-feet. The single year construction water demand of 145 acre-feet and the annual operational water needs of 5 acre-feet are miniscule (0.04 percent and 0.0015 percent, respectively) compared to the available groundwater in storage. Furthermore, the long term annual operational water needs are much less than the estimated annual recharge of 200 acre-feet per year. Overall, there is adequate water available to supply the Project water needs during single dry, and multiple dry year periods.

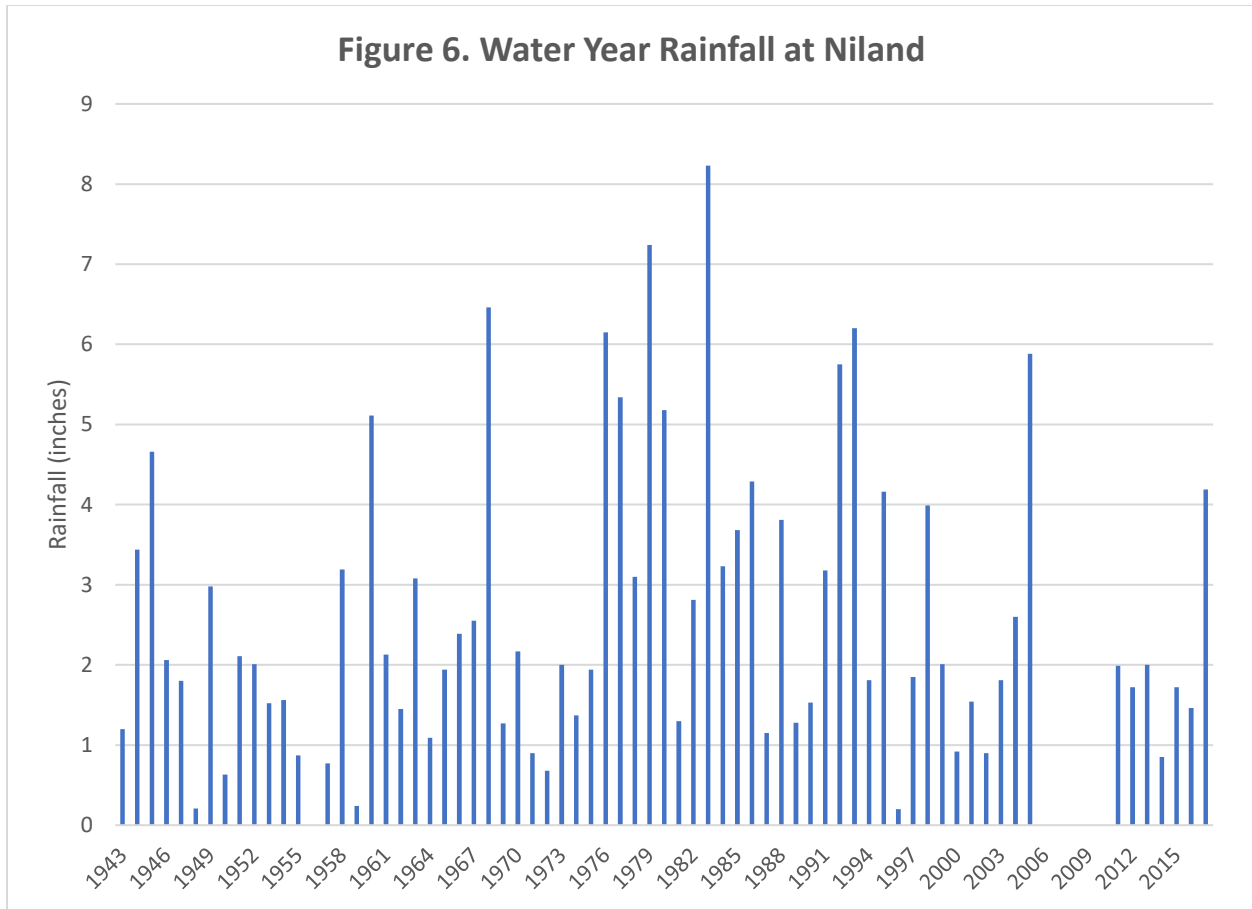

7.0 FINDINGS and DISCUSSION

This WSA has been prepared in accordance with SB 610 and SB 1262 to support the CEQA environmental review for the proposed Project and provides an assessment of water supply adequacy for the Project in accordance with Water Code Sections 10910 through 10915. As stated in Section 1.0, the purpose of the assessment is to determine if available water supplies are sufficient to serve the demand generated by the Project, as well as the reasonably foreseeable demand in the region over the next 20 years under average normal year, single dry year, and multiple dry year conditions. As noted in Section 4.2, above, while groundwater levels in the Basin had been declining during the period from the late 1970s to the early 2000s, over the past decade they have stabilized, indicating that current water demands are in balance with recharge and replenishment. The population, and presumably the related water demand, are anticipated to decrease over the next decade. Therefore, the Basin has adequate resources for current and anticipated future existing water needs.

The water demand for the proposed Project will consist of water needed during construction and water needed for maintenance once the Project is operational. The construction water demand is anticipated to be 145 acre-feet over 12 months, primarily

for dust control. The operational demand is anticipated to be 5 acre-feet per year for panel washing and other maintenance activities. The operational demand will exist for the life of the Project, which is anticipated to be 25 to 30 years.

The construction water demand is short-term and temporary, and is less than the reported average annual recharge to the Basin of 200 acre-feet per year (DWR, 2003). In addition, the single year construction water demand of 145 acre-feet is only 0.04 percent of the available groundwater in storage. This short-term and temporary water use is not anticipated to cause persistent and long-term lowering of groundwater levels. Therefore, the construction water demand will not cause or contribute to overdraft, exhaustion of water supplies, lowering of groundwater levels to depths that would be uneconomic for pumping, land subsidence, or significant alteration of groundwater quality.

The annual operational water needs are equivalent to 2.5 percent of the average annual recharge and 0.0015 percent of the estimated current storage volume of the Basin. Therefore, the long-term operation and maintenance of the Project would not have any measurable effect or impact on groundwater resources in the Basin.

Based on the analysis presented in this WSA, there will be sufficient water available for existing water uses in the Basin, along with the Project water demand during normal, single dry year, and multiple dry year periods for the anticipated life of the Project, which is anticipated to be greater than 20 years.

8.0 DOCUMENTS CONSIDERED AND REFERENCES CITED

- Department of Water Resources (DWR), 2003, Bulletin 118 Update 2003 – Basin Report 7_033, <https://data.cnra.ca.gov/dataset/bulletin-118-update-2003-basin-reports/resource/bf769048-ac5c-4cb5-a03b-0cf12205dc4d>, accessed November 28, 2022.
- Department of Water Resources (DWR), 2021, California’s Groundwater Update 2020, Bulletin 118, https://data.cnra.ca.gov/dataset/calgw_update2020/resource/d2b45d3c-52c0-45ba-b92a-fb3c90c1d4be, accessed November 23, 2022.
- Department of Water Resources (DWR), 2022a, Bulletin 118 Groundwater Basin Lookup, <https://dwr.maps.arcgis.com/apps/Style/index.html?appid=740d10eefd6148579321a3abcd065a36>, accessed November 28, 2022.
- Department of Water Resources (DWR), 2022b, SGMA Data Viewer, <https://sgma.water.ca.gov/webgis/?appid=SGMADataViewer#boundaries>, accessed November 22 and 30, 2022.
- Department of Water Resources (DWR), 2022c, SGMA Basin Prioritization Dashboard, <https://gis.water.ca.gov/app/bp-dashboard/final/>, accessed November 29, 2022.
- Imperial Irrigation District (IID), 2023, Public Water Map, <https://mygis.iid.com/portal/apps/webappviewer/index.html?id=a33cfefb3714f4eb8a1c85320613a2d1b>, accessed February 3, 2023.
- U.S. Geological Survey (USGS), 2023a, National Water Information System (NWIS) website, https://nwis.waterdata.usgs.gov/usa/nwis/gwlevels/?site_no=331144115231501, accessed February 2, 2023.
- U.S. Geological Survey (USGS), 2023a, National Water Information System (NWIS) website, https://nwis.waterdata.usgs.gov/usa/nwis/qwdata/?site_no=331144115231501, accessed February 3, 2023.
- Western Region Climate Center (WRCC), 2022, Niland, California Climate Summary, <https://wrcc.dri.edu/cgi-bin/cliMAIN.pl?ca6197>, accessed November 29, 2022.

Air Quality and Greenhouse Gas Emissions Assessment for the North Star 1 Project

County of Imperial, California

Prepared For:

ZGlobal, Inc.
604 Sutter Street, Suite 250
Folsom, California 95630

Prepared By:



ECORP Consulting, Inc.
ENVIRONMENTAL CONSULTANTS

2525 Warren Drive
Rocklin, California 95677

February 28, 2023

CONTENTS

1.0	INTRODUCTION	1
1.1	Project Overview.....	1
1.2	Project Location.....	1
1.3	Project Construction	1
2.0	AIR QUALITY	4
2.1	Air Quality Setting.....	4
2.1.1	Salton Sea Air Basin.....	4
2.1.2	Criteria Air Pollutants.....	5
2.1.3	Toxic Air Contaminants.....	8
2.1.4	Ambient Air Quality.....	8
2.1.5	Sensitive Receptors.....	10
2.2	Regulatory Framework.....	11
2.2.1	Federal	11
2.2.2	State.....	11
2.2.3	Local.....	13
2.3	Air Quality Emissions Impact Assessment.....	14
2.3.1	Thresholds of Significance	14
2.3.2	Methodology	15
2.3.3	Impact Analysis.....	16
3.0	GREENHOUSE GAS EMISSIONS	25
3.1	Greenhouse Gas Setting.....	25
3.1.1	Sources of Greenhouse Gas Emissions	27
3.2	Regulatory Framework.....	27
3.2.1	State.....	27
3.3	Greenhouse Gas Emissions Impact Assessment	28
3.3.1	Thresholds of Significance	28
3.3.2	Methodology	30
3.3.3	Impact Analysis.....	30
4.0	REFERENCES.....	35

LIST OF FIGURES

Figure 1. Project Regional Map.....	2
Figure 2. Project Vicinity Map.....	3

LIST OF TABLES

Table 1. Criteria Air Pollutants- Summary of Common Sources and Effects5

Table 2. Summary of Ambient Air Quality Data9

Table 3. Attainment Status of Criteria Pollutants in the Imperial County Portion of the SSAB..... 10

Table 4. ICAPCD Significance Thresholds – Pounds per Day 15

Table 5. Unmitigated Project Construction-Generated Emissions..... 17

Table 6. Mitigated Project Construction-Generated Emissions 18

Table 7. Operational-Related Emissions (Regional Significance Analysis)..... 19

Table 8. Proposed Project Displaced Criteria Pollutant Emissions (Tons)..... 21

Table 9. Greenhouse Gases 26

Table 10. Construction-Related Greenhouse Gas Emissions..... 31

Table 11. Operational-Related Greenhouse Gas Emissions..... 31

Table 12. Life-Cycle Greenhouse Gas Emissions for Various Types of Energy Generators 32

Table 13. Proposed Project Displaced GHG Emissions (Metric Tons)..... 33

LIST OF APPENDICES

- Appendix A – CalEEMod Output Files Criteria Air Pollutants & Greenhouse Gas Emissions
- Appendix B – Renewable Energy Emissions Displacement

LIST OF ACRONYMS AND ABBREVIATIONS

Term	Definition
°F	Degrees Fahrenheit
µg/m ³	Micrograms per cubic meter; ppm = parts per million
1992 CO Plan	1992 Federal Attainment Plan for Carbon Monoxide
AB	Assembly Bill
AQMD	Air Quality Management District
CAA	Clean Air Act
CAAQS	California Ambient Air Quality Standards
CalEEMod	California Emissions Estimator Model
Caltrans	California Department of Transportation
CAPCOA	California Air Pollution Control Officers Association
CARB	California Air Resources Board
CCAA	California Clean Air Act
CCR	California Code of Regulations
CEQA	California Environmental Quality Act
CH ₄	Methane
CO ₂	Carbon dioxide

CO ₂ e	Carbon dioxide equivalent
County	Imperial County
CUP	Conditional Use Permit
DPM	Diesel particulate matter
EO	Executive Order
GHG	Greenhouse gas
GWP	Global warming potential
HSAT	Horizontal Single-Axis Tracker
ICAPCD	Imperial County Air Pollution Control District
IPCC	Intergovernmental Panel on Climate Change
MWAC	Megawatt Alternating Current
N ₂ O	Nitrous oxide
NAAQS	National Ambient Air Quality Standards
NO ₂	Nitrogen dioxide
NO _x	Nitric oxides
O ₃	Ozone
PM	Particulate matter
PM ₁₀	Coarse particulate matter
PM _{2.5}	Fine particulate matter
ppb	Parts per billion
Project	North Star 1 Project
PV	Photovoltaic
ROGs	Reactive organic gases
SB	Senate Bill
SCAQMD	South Coast Air Quality Management
SIP	State Implementation Plan
SO ₂	Sulfur dioxide
SO _x	Sulfur oxides
SR	State Route
SRA	Source receptor area
SSAB	Salton Sea Air Basin
TACs	Toxic air contaminants
USEPA	U.S. Environmental Protection Agency
VOC	Volatile organic compound
VMT	Vehicle Miles Traveled

1.0 INTRODUCTION

This report documents the results of an assessment of both air quality and greenhouse gas (GHG) emissions completed for the North Star 1 Project (Project), which includes the construction of a nominal 50-megawatt (MW) alternating current solar photovoltaic (PV) energy generation system with an integrated 75 MW battery storage system spanning approximately 287 acres of land in the County of Imperial, California. This assessment was prepared using methodologies and assumptions recommended in the rules and regulations promulgated by the Imperial County Air Pollution Control District (ICAPCD). Regional and local existing conditions are presented, along with pertinent emissions standards and regulations.

1.1 Project Overview

The Project proposes to construct a nominal 50 MW alternating current PV energy generation system, accompanied by a 75 MW battery storage, utilizing either thin film or crystalline solar PV technology modules mounted either on fixed frames or horizontal single-axis tracker (HSAT) systems. The fixed frame PV module arrays would be mounted on racks supported by driven piles. The individual PV systems would be arranged in large arrays by placing them in columns spaced approximately 10 feet apart to maximize operational performance and to allow access for panel cleaning and maintenance. Operational water supply for the Project would be trucked in from offsite over the life of the Project.

1.2 Project Location

The total combined Project Site spans approximately 287 acres and is located 6.1 miles north of the unincorporated community of Niland, and approximately 8.2 miles east of the community of Bombay Beach, between the East Highline Canal and Coachella Canal (Figures 1 and 2). The irregular shaped site is bound by vacant desert lands to the west, north, and east, and agricultural land to the south. The Project site is currently characterized by flat and undeveloped desert landscape.

1.3 Project Construction

Construction activities would involve site preparation and grubbing, grading of the Project Area to establish access roads and pads for electrical equipment (inverters and step-up transformers), trenching for underground electrical collection lines, and the installation of solar equipment and security fencing. The construction of the Project is estimated to take approximately 12 months. A temporary, portable construction supply container would be located at the Project Site at the beginning of construction and removed at the end of construction. Onsite parking would be provided for all construction workers.

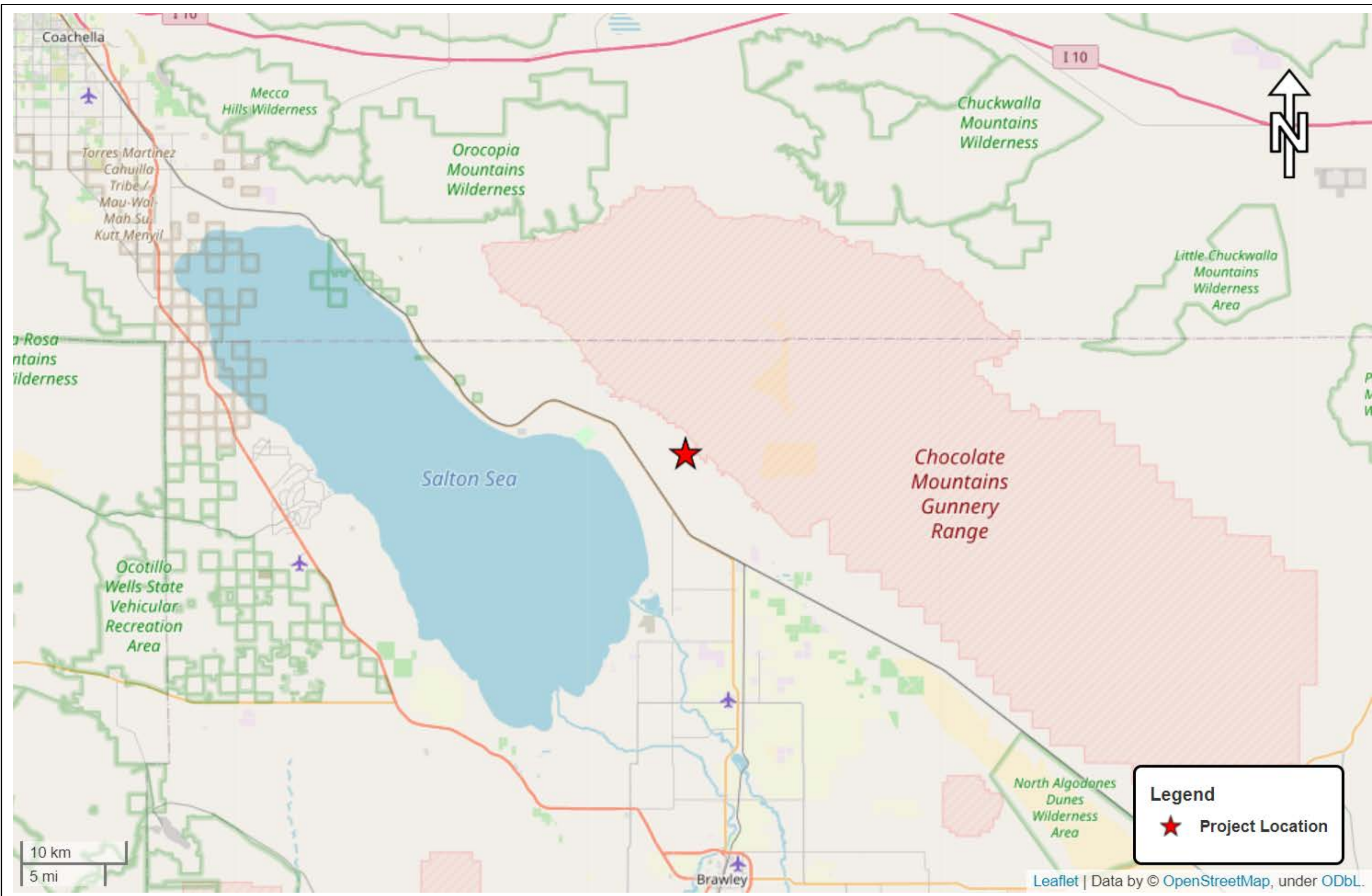

Map Date: 5/12/2022
 Photo (or Base) Source: ECORP Consulting, Inc.



Figure 1. Project Regional Map

2022-102 North Star 1 Project

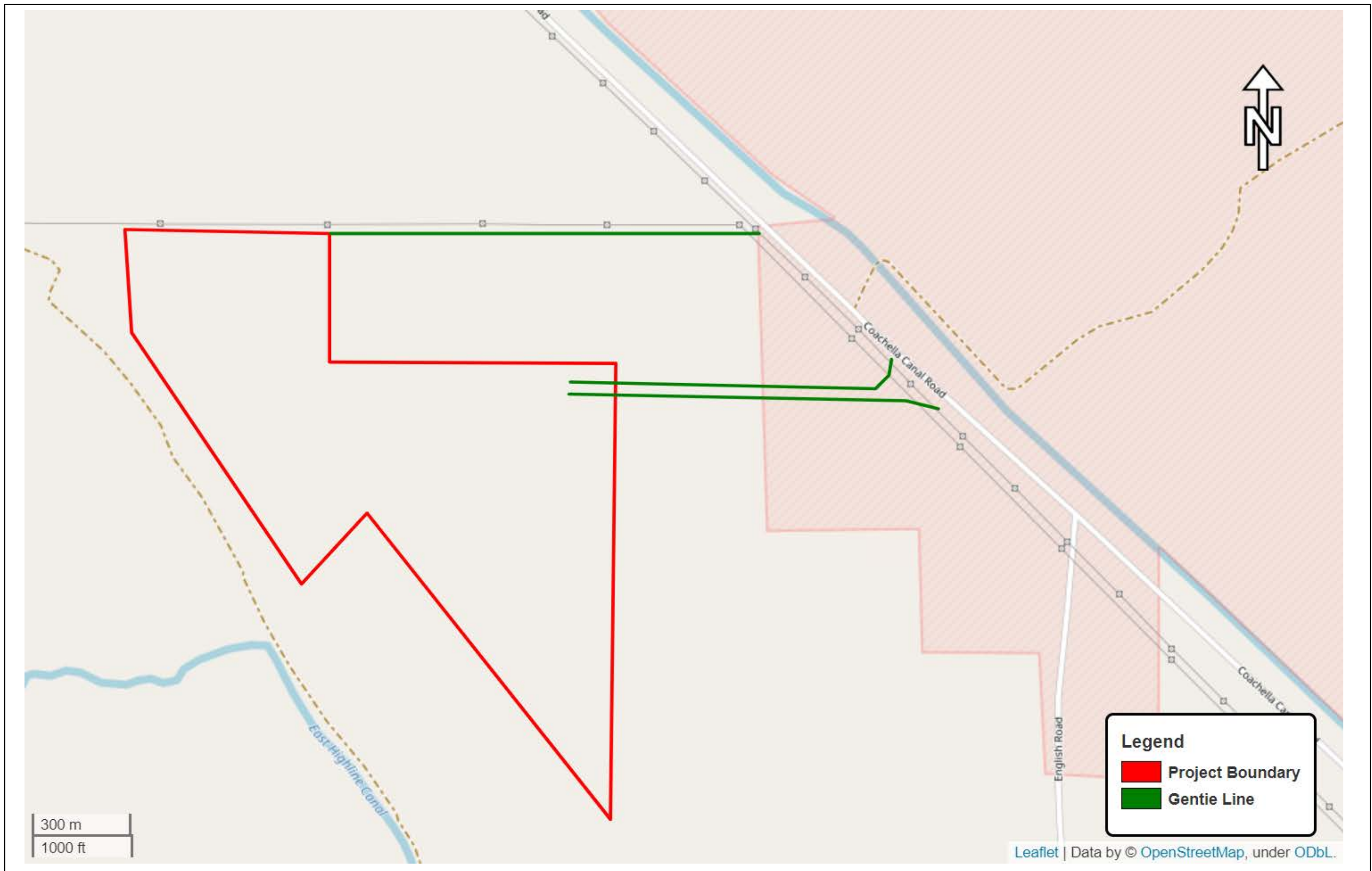

Map Date: 5/12/2022
 Photo (or Base) Source: ECORP Consulting, Inc.

Figure 2. Project Vicinity Map

2.0 AIR QUALITY

2.1 Air Quality Setting

Air quality in a region is determined by its topography, meteorology, and existing air pollutant sources. These factors are discussed below, along with the current regulatory structure that applies to the Salton Sea Air Basin (SSAB), which encompasses the Project Site, pursuant to the regulatory authority of the ICAPCD.

Ambient air quality is commonly characterized by climate conditions, the meteorological influences on air quality, and the quantity and type of pollutants released. The air basin is subject to a combination of topographical and climatic factors that reduce the potential for high levels of regional and local air pollutants. The following section describes the pertinent characteristics of the air basin and provides an overview of the physical conditions affecting pollutant dispersion in the Project Area.

2.1.1 Salton Sea Air Basin

The California Air Resources Board (CARB) divides the State into air basins that share similar meteorological and topographical features. Imperial County, which extends over 4,482 square miles in the southeastern corner of California, lies in the SSAB, which includes the Imperial Valley and the central part of Riverside County, including the Coachella Valley. The province is characterized by the large-scale sinking and warming of air within the semi-permanent subtropical high-pressure center over the Pacific Ocean. The elevation in Imperial County ranges from about 230 feet below sea level in the Salton Sea to more than 2,800 feet on the mountain summits to the east.

2.1.1.1 Temperature and Precipitation

The flat terrain near the Salton Sea, intense heat from the sun during the day, and strong radiational cooling at night create deep convective thermals during the daytime and equally strong surface-based temperature inversions at night. The temperature inversions and light nighttime winds trap any local air pollution emissions near the ground. The area is subject to frequent hazy conditions at sunrise, followed by rapid daytime dissipation as winds pick up and the temperature warms. The lack of clouds and atmospheric moisture creates strong diurnal and seasonal temperature variations ranging from an average summer maximum of 108 degrees Fahrenheit (° F) down to a winter morning minimum of 38° F. The most pleasant weather occurs from about mid-October to early May when daily highs are in the 70s and 80s with very infrequent cloudiness or rainfall. Imperial County experiences rainfall on an average of only four times per year (>0.10 inches in 24 hours). The local area usually has three days of rain in winter and one thunderstorm day in August. The annual rainfall in this region is less than three inches per year (ICAPCD 2010).

2.1.1.2 Wind

Winds in the area are driven by a complex pattern of local, regional and global forces, but primarily reflect the temperature difference between the cool ocean to the west and the heated interior of the entire

desert southwest. For much of the year, winds flow predominantly from the west to the east. In summer, intense solar heating in the Imperial Valley creates a more localized wind pattern, as air comes up from the southeast via the Gulf of California. During periods of strong solar heating and intense convection, turbulent motion creates good mixing and low levels of air pollution. However, even strong turbulent mixing is insufficient to overcome the limited air pollution controls on sources in the Mexicali, Mexico area. Imperial County is predominately agricultural land. This is a factor in the cumulative air quality of the SSAB. The agricultural production generates dust and small particulate matter through the use of agricultural equipment on unpaved roads, land preparation, and harvest practices. The Imperial County experiences unhealthful air quality from photochemical smog and from dust due to extensive surface disturbance and the very arid climate (ICAPCD 2010).

2.1.1.3 *Inversion*

The entire county is affected by inversion layers, where warm air overlays cooler air. Inversion layers trap pollutants close to the ground. In the winter, these pollutant-trapping, ground-based inversions are formed during windless, clear-sky conditions, as cold air collects in low-lying areas such as valleys and canyons. Imperial County experiences surface inversions almost every day of the year. Due to strong surface heating, these inversions are usually broken allowing pollutants to be more easily dispersed (ICAPCD 2010).

2.1.2 **Criteria Air Pollutants**

Criteria air pollutants are defined as those pollutants for which the federal and state governments have established air quality standards for outdoor or ambient concentrations to protect public health with a determined margin of safety. Ozone (O₃), coarse particulate matter (PM₁₀), and fine particulate matter (PM_{2.5}) are generally considered to be regional pollutants because they or their precursors affect air quality on a regional scale. Pollutants such as carbon monoxide (CO), nitrogen dioxide (NO₂), and sulfur dioxide (SO₂) are considered to be local pollutants because they tend to accumulate in the air locally. PM is also considered a local pollutant. Health effects commonly associated with criteria pollutants are summarized in Table 1.

Table 1. Criteria Air Pollutants- Summary of Common Sources and Effects		
Pollutant	Major Manmade Sources	Human Health & Welfare Effects
CO	An odorless, colorless gas formed when carbon in fuel is not burned completely; a component of motor vehicle exhaust.	Reduces the ability of blood to deliver oxygen to vital tissues, affecting the cardiovascular and nervous system. Impairs vision, causes dizziness, and can lead to unconsciousness or death.
NO ₂	A reddish-brown gas formed during fuel combustion for motor vehicles, energy utilities and industrial sources.	Respiratory irritant; aggravates lung and heart problems. Precursor to ozone and acid rain. Causes brown discoloration of the atmosphere.

Table 1. Criteria Air Pollutants- Summary of Common Sources and Effects		
Pollutant	Major Manmade Sources	Human Health & Welfare Effects
O ₃	Formed by a chemical reaction between reactive organic gases (ROGs) and nitrous oxides (N ₂ O) in the presence of sunlight. Common sources of these precursor pollutants include motor vehicle exhaust, industrial emissions, solvents, paints and landfills.	Irritates and causes inflammation of the mucous membranes and lung airways; causes wheezing, coughing and pain when inhaling deeply; decreases lung capacity; aggravates lung and heart problems. Damages plants; reduces crop yield.
PM ₁₀ & PM _{2.5}	Power plants, steel mills, chemical plants, unpaved roads and parking lots, wood-burning stoves and fireplaces, automobiles and others.	Increased respiratory symptoms, such as irritation of the airways, coughing, or difficulty breathing; aggravated asthma; development of chronic bronchitis; irregular heartbeat; nonfatal heart attacks; and premature death in people with heart or lung disease. Impairs visibility (haze).
SO ₂	A colorless, nonflammable gas formed when fuel containing sulfur is burned. Examples are refineries, cement manufacturing, and locomotives.	Respiratory irritant. Aggravates lung and heart problems. Can damage crops and natural vegetation. Impairs visibility.

Source: California Air Pollution Control Officers Association (CAPCOA 2013)

2.1.2.1 Carbon Monoxide

CO in the urban environment is associated primarily with the incomplete combustion of fossil fuels in motor vehicles. CO combines with hemoglobin in the bloodstream and reduces the amount of oxygen that can be circulated through the body. High CO concentrations can cause headaches, aggravate cardiovascular disease and impair central nervous system functions. CO concentrations can vary greatly over comparatively short distances. Relatively high concentrations of CO are typically found near crowded intersections and along heavy roadways with slow moving traffic. Even under the most severe meteorological and traffic conditions, high concentrations of CO are limited to locations within relatively short distances of the source. Overall CO emissions are decreasing as a result of the Federal Motor Vehicle Control Program, which has mandated increasingly lower emission levels for vehicles manufactured since 1973. CO levels in the SSAB are in compliance with the state and federal one- and eight-hour standards.

2.1.2.2 Nitrogen Oxides

Nitrogen gas comprises about 80 percent of the air and is naturally occurring. At high temperatures and under certain conditions, nitrogen can combine with oxygen to form several different gaseous compounds collectively called nitric oxides (NO_x). Motor vehicle emissions are the main source of NO_x in urban areas. NO_x is very toxic to animals and humans because of its ability to form nitric acid with water in the eyes, lungs, mucus membrane, and skin. In animals, long-term exposure to NO_x increases

susceptibility to respiratory infections, and lowers resistance to such diseases as pneumonia and influenza. Laboratory studies show that susceptible humans, such as asthmatics, who are exposed to high concentrations can suffer from lung irritation or possible lung damage. Precursors of NO_x , such as NO and NO_2 , attribute to the formation of O_3 and $\text{PM}_{2.5}$. Epidemiological studies have also shown associations between NO_2 concentrations and daily mortality from respiratory and cardiovascular causes and with hospital admissions for respiratory conditions.

2.1.2.3 Ozone

O_3 is a secondary pollutant, meaning it is not directly emitted. It is formed when volatile organic compounds (VOCs) or ROGs and NO_x undergo photochemical reactions that occur only in the presence of sunlight. The primary source of ROG emissions is unburned hydrocarbons in motor vehicle and other internal combustion engine exhaust. NO_x forms as a result of the combustion process, most notably due to the operation of motor vehicles. Sunlight and hot weather cause ground-level O_3 to form. Ground-level O_3 is the primary constituent of smog. Because O_3 formation occurs over extended periods of time, both O_3 and its precursors are transported by wind and high O_3 concentrations can occur in areas well away from sources of its constituent pollutants.

People with lung disease, children, older adults, and people who are active can be affected when O_3 levels exceed ambient air quality standards. Numerous scientific studies have linked ground-level O_3 exposure to a variety of problems including lung irritation, difficult breathing, permanent lung damage to those with repeated exposure, and respiratory illnesses.

2.1.2.4 Particulate Matter

PM includes both aerosols and solid particulates of a wide range of sizes and composition. Of concern are those particles smaller than or equal to 10 microns in diameter size (PM_{10}) and smaller than or equal to 2.5 microns in diameter ($\text{PM}_{2.5}$). Smaller particulates are of greater concern because they can penetrate deeper into the lungs than larger particles. PM_{10} is generally emitted directly as a result of mechanical processes that crush or grind larger particles or form the resuspension of dust, typically through construction activities and vehicular travel. PM_{10} generally settles out of the atmosphere rapidly and is not readily transported over large distances. $\text{PM}_{2.5}$ is directly emitted in combustion exhaust and is formed in atmospheric reactions between various gaseous pollutants, including NO_x , sulfur oxides (SO_x) and VOCs. $\text{PM}_{2.5}$ can remain suspended in the atmosphere for days and/or weeks and can be transported long distances.

The principal health effects of airborne PM are on the respiratory system. Short-term exposure of high $\text{PM}_{2.5}$ and PM_{10} levels are associated with premature mortality and increased hospital admissions and emergency room visits. Long-term exposure is associated with premature mortality and chronic respiratory disease. According to the U.S. Environmental Protection Agency (USEPA), some people are much more sensitive than others to breathing PM_{10} and $\text{PM}_{2.5}$. People with influenza, chronic respiratory and cardiovascular diseases, and the elderly may suffer worse illnesses; people with bronchitis can expect aggravated symptoms; and children may experience decline in lung function due to breathing in PM_{10} and

PM_{2.5}. Other groups considered sensitive include smokers and people who cannot breathe well through their noses. Exercising athletes are also considered sensitive because many breathe through their mouths.

2.1.3 Toxic Air Contaminants

In addition to the criteria pollutants discussed above, toxic air contaminants (TACs) are another group of pollutants of concern. TACs are considered either carcinogenic or noncarcinogenic based on the nature of the health effects associated with exposure to the pollutant. For regulatory purposes, carcinogenic TACs are assumed to have no safe threshold below which health impacts would not occur, and cancer risk is expressed as excess cancer cases per one million exposed individuals. Noncarcinogenic TACs differ in that there is generally assumed to be a safe level of exposure below which no negative health impact is believed to occur. These levels are determined on a pollutant-by-pollutant basis.

There are many different types of TACs, with varying degrees of toxicity. Sources of TACs include industrial processes such as petroleum refining and chrome plating operations, commercial operations such as gasoline stations and dry cleaners, and motor vehicle exhaust. Additionally, diesel engines emit a complex mixture of air pollutants composed of gaseous and solid material. The solid emissions in diesel exhaust are known as diesel particulate matter (DPM). In 1998, California identified DPM as a TAC based on its potential to cause cancer, premature death, and other health problems (e.g., asthma attacks and other respiratory symptoms). Those most vulnerable are children (whose lungs are still developing) and the elderly (who may have other serious health problems). Overall, diesel engine emissions are responsible for the majority of California's known cancer risk from outdoor air pollutants. Public exposure to TACs can result from emissions from normal operations, as well as from accidental releases of hazardous materials during upset conditions. The health effects of TACs include cancer, birth defects, neurological damage, and death.

2.1.3.1 Diesel Exhaust

Most recently, CARB identified DPM as a TAC. DPM differs from other TACs in that it is not a single substance but rather a complex mixture of hundreds of substances. Diesel exhaust is a complex mixture of particles and gases produced when an engine burns diesel fuel. DPM is a concern because it causes lung cancer; many compounds found in diesel exhaust are carcinogenic. DPM includes the particle-phase constituents in diesel exhaust. The chemical composition and particle sizes of DPM vary between different engine types (heavy-duty, light-duty), engine operating conditions (idle, accelerate, decelerate), fuel formulations (high/low sulfur fuel), and the year of the engine (USEPA 2002). Some short-term (acute) effects of diesel exhaust include eye, nose, throat, and lung irritation, and diesel exhaust can cause coughs, headaches, light-headedness, and nausea. DPM poses the greatest health risk among the TACs; due to their extremely small size, these particles can be inhaled and eventually trapped in the bronchial and alveolar regions of the lung.

2.1.4 Ambient Air Quality

Ambient air quality at the Project Site can be inferred from ambient air quality measurements conducted at nearby air quality monitoring stations. CARB maintains more than 60 monitoring stations throughout

California. O₃, PM₁₀ and PM_{2.5} are the pollutant species most potently affecting the Project region. As described in detail below, the Project region is designated as a nonattainment area for the federal O₃ and PM_{2.5} standards and is also a nonattainment area for the state standards for O₃ and PM₁₀ (CARB 2019). The Niland-English Road air quality monitoring station (7711 English Road, Niland), located approximately 8.1 miles south of the Project Site, monitors ambient concentrations of O₃ and PM₁₀. The Brawley-Main Street #2 air quality monitoring station (220 Main Street, Brawley), located 24 miles south of the Project Site, monitors ambient concentrations of PM_{2.5}. Ambient emission concentrations will vary due to localized variations in emission sources and climate and should be considered “generally” representative of ambient concentrations in the Project area.

Table 2 summarizes the published data concerning O₃, PM_{2.5} and PM₁₀ from the Niland-English Road and Brawley-Main Street #2 monitoring stations for each year that the monitoring data is provided. O₃, PM₁₀ and PM_{2.5} are the pollutant species most potently affecting the Project region.

Table 2. Summary of Ambient Air Quality Data			
Pollutant Standards	2018	2019	2020
O₃- Niland-English Road			
Max 1-hour concentration (ppm)	0.060	0.060	0.054
Max 8-hour concentration (ppm) (state/federal)	0.055 / 0.055	0.055 / 0.054	0.046 / 0.045
Number of days above 1-hour standard (state/federal)	0 / 0	0 / 0	0 / 0
Number of days above 8-hour standard (state/federal)	0 / 0	0 / 0	0 / 0
PM₁₀- Niland-English Road			
Max 24-hour concentration (µg/m ³) (state/federal)	333.8 / 331.5	156.3 / 155.7	241.3 / 239.8
Number of days above 24-hour standard (state/federal)	* / 10.1	49.3 / 1.0	68.9 / 1.0
PM_{2.5}- Brawley-Main Street			
Max 24-hour concentration (µg/m ³) (state/federal)	55.1 / 55.1	28.9 / 28.9	23.7 / 23.7
Number of days above federal 24-hour standard	6.1	0	0

Source: CARB 2021a

µg/m³ = micrograms per cubic meter; ppm = parts per million

* = Insufficient data available

The USEPA and CARB designate air basins or portions of air basins and counties as being in “attainment” or “nonattainment” for each of the criteria pollutants. Areas that do not meet the standards are classified

as nonattainment areas. The National Ambient Air Quality Standards (NAAQS) (other than O₃, PM₁₀ and PM_{2.5} and those based on annual averages or arithmetic mean) are not to be exceeded more than once per year. The NAAQS for O₃, PM₁₀, and PM_{2.5} are based on statistical calculations over one- to three-year periods, depending on the pollutant. The California Ambient Air Quality Standards (CAAQS) are not to be exceeded during a three-year period. The attainment status for the portion of the SSAB encompassing the Project Site is included in Table 3.

Pollutant	State Designation	Federal Designation
O ₃	Nonattainment	Nonattainment
PM ₁₀	Nonattainment	Attainment
PM _{2.5}	Attainment	Nonattainment
CO	Attainment	Unclassified/Attainment
NO ₂	Attainment	Unclassified/Attainment
SO ₂	Attainment	Unclassified/Attainment

Source: CARB 2019

The determination of whether an area meets the state and federal standards is based on air quality monitoring data. Some areas are unclassified, which means there is insufficient monitoring data for determining attainment or nonattainment. Unclassified areas are typically treated as being in attainment. Because the attainment/nonattainment designation is pollutant-specific, an area may be classified as nonattainment for one pollutant and attainment for another. Similarly, because the state and federal standards differ, an area could be classified as attainment for the federal standards of a pollutant and as nonattainment for the state standards of the same pollutant. The region is designated as a nonattainment area for the federal O₃ and PM_{2.5} standards and is also a nonattainment area for the state standards for O₃ and PM₁₀ (CARB 2019).

2.1.5 Sensitive Receptors

Sensitive receptors are defined as facilities or land uses that include members of the population who are particularly sensitive to the effects of air pollutants, such as children, the elderly, and people with illnesses. Examples of these sensitive receptors are residences, schools, hospitals, and daycare centers. CARB has identified the following groups of individuals as the most likely to be affected by air pollution: the elderly over 65, children under 14, athletes, and persons with cardiovascular and chronic respiratory diseases such as asthma, emphysema, and bronchitis. The nearest existing noise-sensitive land use to the Project Site is a single-family residence located approximately 450 feet from the western boundary of the North Star 1 Project boundary.

2.2 Regulatory Framework

2.2.1 Federal

2.2.1.1 Clean Air Act

The Clean Air Act (CAA) of 1970 and the CAA Amendments of 1971 required the USEPA to establish the NAAQS, with states retaining the option to adopt more stringent standards or to include other specific pollutants. On April 2, 2007, the Supreme Court found that carbon dioxide (CO₂) is an air pollutant covered by the CAA; however, no NAAQS have been established for CO₂.

These standards are the levels of air quality considered safe, with an adequate margin of safety, to protect the public health and welfare. They are designed to protect those “sensitive receptors” most susceptible to further respiratory distress such as asthmatics, the elderly, very young children, people already weakened by other disease or illness, and persons engaged in strenuous work or exercise. Healthy adults can tolerate occasional exposure to air pollutant concentrations considerably above these minimum standards before adverse effects are observed.

The USEPA has classified air basins (or portions thereof) as being in attainment, nonattainment, or unclassified for each criteria air pollutant, based on whether or not the NAAQS have been achieved. If an area is designated unclassified, it is because inadequate air quality data were available as a basis for a nonattainment or attainment designation. Table 3 lists the federal attainment status of the SSAB for the criteria pollutants.

2.2.2 State

2.2.2.1 California Clean Air Act

The California Clean Air Act (CCAA) allows the state to adopt ambient air quality standards and other regulations provided that they are at least as stringent as federal standards. CARB, a part of the California Environmental Protection Agency, is responsible for the coordination and administration of both federal and state air pollution control programs within California, including setting the CAAQS. CARB also conducts research, compiles emission inventories, develops suggested control measures, and provides oversight of local programs. CARB establishes emissions standards for motor vehicles sold in California, consumer products (such as hairspray, aerosol paints, and barbecue lighter fluid), and various types of commercial equipment. It also sets fuel specifications to further reduce vehicular emissions. CARB also has primary responsibility for the development of California’s State Implementation Plan (SIP), for which it works closely with the federal government and the local air districts.

2.2.2.2 California State Implementation Plan

The CCAA (and its subsequent amendments) requires the state to prepare an air quality control plan referred to as the SIP. The SIP is a living document that is periodically modified to reflect the latest emissions inventories, plans, and rules and regulations of air basins as reported by the agencies with jurisdiction over them. The CAA Amendments dictate that states containing areas violating the NAAQS

revise their SIPs to include extra control measures to reduce air pollution. The SIP includes strategies and control measures to attain the NAAQS by deadlines established by the CAA. The USEPA has the responsibility to review all SIPs to determine if they conform to the requirements of the CAA. State law makes CARB the lead agency for all purposes related to the SIP. Local air districts and other agencies prepare SIP elements and submit them to CARB for review and approval. CARB then forwards SIP revisions to the USEPA for approval and publication in the Federal Register.

Local air districts, such as the ICAPCD, prepare air quality attainment plans or air quality management plans and submit them to CARB for review, approval, and incorporation into the applicable SIP. The air districts develop the strategies stated in the SIPs for achieving air quality standards on a regional basis.

For 8-Hour O₃, the ICAPCD adopted the 2017 8-hour Ozone State Implementation Plan in October 2018. The plan includes control measures which are an integral part of how the ICAPCD currently controls the ROG and NO_x emissions within the O₃ nonattainment areas. The overall strategy includes programs and control measures which represent the implementation of Reasonable Available Control Technology (40 CFR 51.912) and the assurance that stationary sources maintain a net decrease in emissions.

For PM₁₀, the ICAPCD adopted the PM₁₀ State Implementation Plan in 2018, which maintained previously adopted fugitive dust control measures (Regulation VIII). The USEPA had previously approved Regulation VIII fugitive dust rules into the Imperial County portion of the California SIP in 2013.

For PM_{2.5}, the ICAPCD adopted the PM_{2.5} SIP in April 2018. This SIP concluded that the majority of the PM_{2.5} emissions resulted from transport in nearby Mexico. Specifically, the SIP demonstrates attainment of the 2006 PM_{2.5} NAAQS “but for” transport of international emissions from Mexicali, Mexico. In accordance with the CCAA, the PM_{2.5} SIP satisfies the attainment demonstration requirement satisfying the provisions of the CCAA.

The ICAPCD is working cooperatively with counterparts from Mexico to implement emissions reductions strategies and projects for air quality improvements at the border. The two countries strive to achieve these goals through local input from states, County governments, and citizens. Within the Mexicali and Imperial Valley area, the Air Quality Task Force (AQTF) has been organized to address those issues unique to the border region known as the Mexicali/Imperial air shed. The AQTF membership includes representatives from Federal, State, and local governments from both sides of the border, as well as representatives from academia, environmental organizations, and the general public. This group was created to promote regional efforts to improve the air quality monitoring network, emissions inventories, and air pollution transport modeling development, as well as the creation of programs and strategies to improve air quality.

2.2.2.3 *Tanner Air Toxics Act & Air Toxics “Hot Spots” Information and Assessment Act*

CARB’s Statewide comprehensive air toxics program was established in 1983 with Assembly Bill (AB) 1807, the Toxic Air Contaminant Identification and Control Act (Tanner Air Toxics Act of 1983). AB 1807 created California’s program to reduce exposure to air toxics and sets forth a formal procedure for CARB to designate substances as TACs. Once a TAC is identified, CARB adopts an airborne toxics control measure (ATCM) for sources that emit designated TACs. If there is a safe threshold for a substance at which there is

no toxic effect, the control measure must reduce exposure to below that threshold. If there is no safe threshold, the measure must incorporate toxics best available control technology to minimize emissions.

CARB also administers the state's mobile source emissions control program and oversees air quality programs established by state statute, such as AB 2588, the Air Toxics "Hot Spots" Information and Assessment Act of 1987. Under AB 2588, TAC emissions from individual facilities are quantified and prioritized by the air quality management district or air pollution control district. High priority facilities are required to perform a health risk assessment (HRA) and, if specific thresholds are exceeded, required to communicate the results to the public in the form of notices and public meetings. In September 1992, the "Hot Spots" Act was amended by Senate Bill (SB) 1731, which required facilities that pose a significant health risk to the community to reduce their risk through a risk management plan.

2.2.3 Local

2.2.3.1 Imperial County Air Pollution Control District

The ICAPCD is the local air quality agency and shares responsibility with CARB for ensuring that state and federal ambient air quality standards are achieved and maintained in the SSAB. Furthermore, ICAPCD adopts and enforces controls on stationary sources of air pollutants through its permit and inspection programs and regulates agricultural burning. Other ICAPCD responsibilities include monitoring ambient air quality, preparing clean air plans, planning activities such as modeling and maintenance of the emission inventory, and responding to citizen air quality complaints.

To achieve and maintain ambient air quality standards, the ICAPCD has adopted various rules and regulations for the control of airborne pollutants. The ICAPCD Rules and Regulations that are applicable to the Proposed Project include, but are not limited to, ICAPCD Regulation VIII (Fugitive Dust Rules). The purpose of this regulation is to reduce the amount of PM₁₀ entrained in the ambient air as a result of emissions generated from construction and other earthmoving activities by requiring actions to prevent, reduce, or mitigate PM₁₀ emissions. Regulation VIII requires the Project to adopt best available control measures to minimize emissions from surface-disturbing activities. These measures include the following (ICAPCD 2017):

- All disturbed areas, including bulk material storage which is not being actively utilized, shall be effectively stabilized and visible emissions shall be limited to no greater than 20 percent opacity for dust emissions by using water, chemical stabilizers, dust suppressants, tarps, or other suitable material such as vegetative ground cover.
- All on-site and off-site unpaved roads will be effectively stabilized, and visible emissions shall be limited to no greater than 20 percent opacity for dust emissions by paving, chemical stabilizers, or dust suppressants.
- All unpaved traffic areas of 1 acre or more with 75 or more average vehicle trips per day will be effectively stabilized and visible emissions shall be limited to no greater than 20 percent opacity for dust emissions by paving, chemical stabilizers, dust suppressants, and/or watering.

- The transport of bulk materials shall be completely covered unless 6 inches of freeboard space from the top of the container is maintained with no spillage and loss of bulk material. In addition, the cargo compartment of all haul trucks is to be cleaned and/or washed at the delivery site after removal of bulk material.
- All track-out or carry-out will be cleaned at the end of each workday or immediately when mud or dirt extends a cumulative distance of 50 linear feet or more onto a paved road within an urban area.
- Bulk material handling or transfer shall be stabilized prior to handling or at points of transfer with application of sufficient water, chemical stabilizers, or by sheltering or enclosing the operation and transfer line.
- The construction of any new unpaved road is prohibited within any area with a population of 500 or more unless the road meets the definition of a temporary unpaved road. Any temporary unpaved road shall be effectively stabilized and visible emissions shall be limited to no greater than 20 percent opacity for dust emission by paving, chemical stabilizers, dust suppressants and/or watering.

In addition, other ICAPCD rules and regulations may apply to the Proposed Project, but are administrative or descriptive in nature and are not detailed here. These include rules associated with fees, enforcement and penalty actions, and variance procedures.

2.3 Air Quality Emissions Impact Assessment

2.3.1 Thresholds of Significance

The impact analysis provided below is based on the following California Environmental Quality Act (CEQA) Guidelines Appendix G thresholds of significance. The Project would result in a significant impact to air quality if it would do any of the following:

1. Conflict with or obstruct implementation of any applicable air quality plan.
2. Result in a cumulatively considerable net increase of any criteria pollutant for which the Project region is nonattainment under an applicable federal or state ambient air quality standard (including releasing emissions which exceed quantitative thresholds for ozone precursors).
3. Expose sensitive receptors to substantial pollutant concentrations.
4. Result in other emissions (such as those leading to odors adversely affecting a substantial number of people).

2.3.1.1 Imperial County Air Pollution Control District Thresholds

The significance criteria established by the applicable air quality management or air pollution control district (ICAPCD) may be relied upon to make the above determinations. The ICAPCD has identified

significance thresholds for use in evaluating project impacts under CEQA. Accordingly, the ICAPCD-recommended thresholds of significance are used to determine whether implementation of the proposed Project would result in a significant air quality impact. Significance thresholds for evaluation construction and operational air quality impacts are listed in Table 4.

Table 4. ICAPCD Significance Thresholds – Pounds per Day			
Criteria Pollutant and Precursors	Construction Activities	Operations	
	Average Daily Emissions (lbs/day)	Average Daily Emissions (lbs/day)	
		Tier I Threshold	Tier II Threshold
ROG	75	<137	>137
NO _x	100	<137	>137
PM ₁₀	150	<150	>150
PM _{2.5}	N/A	<550	>550
CO	550	<550	>550
SO ₂	N/A	<150	>150

Source: ICAPCD 2017

Projects that are predicted to exceed Tier I thresholds require implementation of applicable ICAPCD standard mitigation measures to be considered less than significant. Projects exceeding Tier II thresholds are required to implement applicable ICAPCD standard mitigation measures, as well as applicable discretionary mitigation measures. Projects that exceed the Tier II thresholds after implementation of standard and discretionary mitigation measures would be considered to have a potentially significant impact to human health and welfare.

By its very nature, air pollution is largely a cumulative impact. No single project is sufficient in size, by itself, to result in nonattainment of ambient air quality standards. Instead, a project's individual emissions contribute to existing cumulatively significant adverse air quality impacts. If a project's individual emissions exceed its identified significance thresholds, the project would be cumulatively considerable. Projects that do not exceed significance thresholds would not be considered cumulative considerable.

2.3.2 Methodology

Air quality impacts were assessed in accordance with methodologies recommended by the ICAPCD. Where criteria air pollutant quantification was required, emissions were modeled using the California Emissions Estimator Model (CalEEMod), version 2020.4.0. CalEEMod is a statewide land use emissions computer model designed to quantify potential criteria pollutant emissions associated with both construction and operations from a variety of land use projects. Project construction-generated air

pollutant emissions were calculated using CalEEMod model defaults for Imperial County. Operational air pollutant emissions were based on the Project Site plans.

2.3.3 Impact Analysis

2.3.3.1 Project Construction-Generated Criteria Air Quality Emissions

Emissions associated with Project implementation would be temporary and short-term but have the potential to represent a significant air quality impact. Two basic sources of short-term emissions will be generated through Project implementation: operation of the heavy-duty equipment (i.e., excavators, loaders, haul trucks) and the creation of fugitive dust during clearing and grading. Construction activities such as excavation and grading operations, construction vehicle traffic, and wind blowing over exposed soils would generate exhaust emissions and fugitive PM emissions that affect local air quality at various times during construction. Effects would be variable depending on the weather, soil conditions, the amount of activity taking place, and the nature of dust control efforts. The dry climate of the area during the summer months creates a high potential for dust generation. Construction activities would be subject to ICAPCD Regulation VIII which, as previously described, requires taking reasonable precautions to reduce the amount of PM₁₀ entrained in the ambient air as a result of emissions generated from construction and other earthmoving activities by requiring actions to prevent, reduce, or mitigate PM₁₀ emissions. Regulation VIII requires the Project to adopt best available control measures to minimize emissions from surface-disturbing activities to comply with ICAPCD Regulation VIII (Fugitive Dust Rules).

Emissions associated with Project off-road equipment, worker commute trips, and ground disturbance were calculated using the CARB-approved CalEEMod computer program, which is designed to model emissions for land use development projects, based on typical construction requirements. See Appendix A for more information regarding the construction assumptions, including types of construction equipment used and Project duration used in this analysis.

Predicted maximum daily emissions attributable to Project construction are summarized in Table 5. Such emissions are short-term and of temporary duration, lasting only as long as Project construction activities occur, but would be considered a significant air quality impact if the volume of pollutants generated exceeds the ICAPCD thresholds of significance.

Table 5. Unmitigated Project Construction-Generated Emissions						
Construction Year	Pollutant (pounds per day)					
	ROG	NO_x	CO	SO₂	PM₁₀	PM_{2.5}
Construction Year One	7.29	61.05	72.83	0.17	273.39	29.96
Construction Year Two	7.00	45.91	70.87	0.17	273.23	29.82
ICAPCD Significance Threshold	75	100	550	N/A	150	N/A
Exceed ICAPCD Threshold?	No	No	No	No	Yes	No

Source: CalEEMod version 2020.4.0. Refer to Appendix A for Model Data Outputs.

Notes: Pounds per day taken from the season with the highest output.

As shown in Table 5, emissions of PM₁₀ would exceed the ICAPCD significance threshold on the peak day(s) of construction, even with the implementation of ICAPCD Regulation VIII emission-reduction measures applied on the Project Site. However, Regulation VIII requires all unpaved roadways, both on and off-site, to be conditioned and maintained with soil stabilizers to reduce dust opacity to no more than 20 percent; all unpaved disturbed surfaces, both on and off-site, to be stabilized with a dust suppressant, watering, or soil stabilizers to reduce opacity to no greater than 20 percent; and to reduce vehicle speed to no greater than 15 mph on all unpaved surfaces. The emissions shown in Table 5 above only consist of modeled emissions with the implementation of ICAPCD Regulation VIII on the Project Site. A predominate source of Project PM₁₀ emissions is workers commuting to and from the Project Site on unpaved roads. Commute vehicles traveling over the exposed soils of unpaved roads generates substantial amounts of fugitive PM₁₀ emissions. The majority of roadways leading to the Project Site are paved; however, the last 1.15 miles of the Project Site access route, beginning with a dirt road traversing north from Hobbs Road, is unpaved roadway. Therefore, mitigation measure AQ-1 is required in order to reduce PM₁₀ emissions to levels below the significance threshold.

The following mitigation is recommended.

AQ-1: In addition to adherence of all Imperial County Air Pollution Control District Regulation VIII requirements on the Project Site during construction, the entire unpaved access route from Hobbs Road to the Project Site shall be effectively stabilized and visible emissions shall be limited to no greater than 20 percent opacity.

Predicted maximum daily emissions associated with Project construction with implementation of mitigation measure AQ-1 are summarized in Table 6.

Table 6. Mitigated Project Construction-Generated Emissions						
Construction Year	Pollutant (pounds per day)					
	ROG	NO_x	CO	SO₂	PM₁₀	PM_{2.5}
Construction Year One	7.29	61.05	72.83	0.17	11.48	5.87
Construction Year Two	7.00	45.91	70.87	0.17	7.74	3.35
ICAPCD Significance Threshold	75	100	550	N/A	150	N/A
Exceed ICAPCD Threshold?	No	No	No	No	No	No

Source: CalEEMod version 2020.4.0. Refer to Appendix A for Model Data Outputs.

Notes: Pounds per day taken from the season with the highest output.

As shown in Table 6, emissions generated during Project construction would not exceed the ICAPCD's thresholds of significance with implementation of mitigation measure AQ-1. With implementation of Mitigation Measure AQ-1, criteria pollutant emissions generated during Project construction would not result in a cumulatively considerable net increase of any criteria pollutant for which the Project region is nonattainment under an applicable federal or state ambient air quality standard, and no health effects from Project criteria pollutants would occur.

2.3.3.2 Operational Criteria Air Quality Emissions

Although limited, implementation of the Project would result in long-term operational emissions of criteria air pollutants such as PM₁₀, PM_{2.5}, CO, and SO₂ as well as O₃ precursors such as ROG and NO_x. Project-generated increases in emissions would be predominately associated with motor vehicle use for routine maintenance work, site security, and trucking in water. Long-term operational emissions attributable to the Project are identified in Table 7 and compared to the operational significance thresholds promulgated by the ICAPCD.

Table 7. Operational-Related Emissions (Regional Significance Analysis)						
Emission Source	Pollutant (pounds per day)					
	ROG	NO_x	CO	SO₂	PM₁₀	PM_{2.5}
Summer Emissions						
Area	5.86	0.00	0.02	0.00	0.00	0.00
Energy	0.00	0.00	0.00	0.00	0.00	0.00
Mobile	0.01	0.77	0.17	0.00	3.54	0.36
Total:	5.57	0.77	0.17	0.00	3.54	0.39
<i>ICAPCD Significance Threshold</i>	<i>137</i>	<i>137</i>	<i>150</i>	<i>550</i>	<i>550</i>	<i>150</i>
Exceed ICAPCD Significance Threshold?	No	No	No	No	No	No
Winter Emissions						
Area	5.86	0.00	0.02	0.00	0.00	0.00
Energy	0.00	0.00	0.00	0.00	0.00	0.00
Mobile	0.01	0.85	0.15	0.00	3.54	0.39
Total:	5.87	0.85	0.17	0.00	3.54	0.39
ICAPCD Significance Threshold	<i>137</i>	<i>137</i>	<i>150</i>	<i>550</i>	<i>550</i>	<i>150</i>
Exceed ICAPCD Significance Threshold?	No	No	No	No	No	No

Source: CalEEMod version 2020.4.0. Refer to Appendix A for Model Data Outputs.

Notes: Operational emissions account for four heavy-duty truck vehicle trip per day. It is noted that this is a conservative estimate and many days will have no operational related vehicle trips.

As shown in Table 7, the Project's emissions would not exceed any ICAPCD's thresholds for any criteria air pollutants during operation. Additionally, the purpose of the Project is the construction of a renewable energy and storage facility. Once in operation, it will decrease the need for energy from fossil fuel-based power plants in the state (see Table 8). Thus, once operational the Project would represent a beneficial impact to air quality.

2.3.3.3 Conflict with an Applicable Air Quality Management Plan

As previously described, the Project region is classified as nonattainment for federal O₃ and PM_{2.5} standards (CARB 2019). The USEPA, under the provisions of the CAA, requires each state with regions that have not attained the federal air quality standards to prepare a SIP, detailing how these standards are to be met in each local area. The SIP is a legal agreement between each state and the federal government to commit resources to improving air quality. It serves as the template for conducting regional and project-

level air quality analysis. CARB is the lead agency for developing the SIP in California. Local air districts, such as the ICAPCD, prepare air quality attainment plans or air quality management plans and submit them to CARB for review, approval, and incorporation into the applicable SIP. The air districts develop the strategies stated in the SIPs for achieving air quality standards on a regional basis.

The region's SIP is constituted of the ICAPCD air quality plans: 2018 PM₁₀ SIP, the 2018 Annual PM_{2.5} SIP, the 2017 8-Hour Ozone SIP, 2013 24-Hour PM_{2.5} SIP, the 2009 1997 8-hour Ozone RACT SIP, the 2009 PM₁₀ SIP and the 2008 Ozone Early Progress Plans. Project compliance with all of the ICAPCD rules and regulations results in conformance with the ICAPCD air quality plans. These air quality attainment plans are a compilation of new and previously submitted plans, programs (such as monitoring, modeling, permitting, etc.), district rules, state regulations, and federal controls describing how the state will attain ambient air quality standards. These SIP plans and associated control measures are based on information derived from projected growth in Imperial County in order to project future emissions and then determine strategies and regulatory controls for the reduction of emissions. Growth projections are based on the general plans developed by Imperial County and the incorporated cities in the county.

As previously described, the Project proposes to construct a 50 MW alternating current PV energy generation system, accompanied by a 75 MW battery storage on 287 acres of land. The Project would not result in population growth and would not cause an increase in currently established population projections. The Project does not include residential development or large local or regional employment centers, and thus would not result in significant population or employment growth.

Furthermore, the operation of the Project would create renewable energy over its planned lifetime and decrease the need for energy from fossil fuel-based power plants in the state, which is considered a beneficial impact to statewide air quality. The energy produced by the Project would displace the criteria pollutant emissions which would otherwise be produced by existing business-as-usual power generation resources (including natural gas and coal).

Table 8 shows the emissions that would potentially be displaced by the Proposed Project. Note that this estimate only includes that associated with the combustion of fossil fuels; it does not include the vehicle trips associated with the Project's operations, and it similarly does not include operational employee trips associated with natural gas or coal combustion nor the emissions associated with extracting and transporting those power sources. In addition, this estimate only includes the displacement of that portion of the California market that comes from fossil fuels and does not include the approximate 50 percent of the California electricity generated by non-combustion sources (wind, solar, nuclear, hydro-electric) (California Energy Commission [CEC] 2020). Displacement of fossil fuel emissions has a direct beneficial effect on human health for those receptors downwind of the location of the fossil fuel power plants.

Table 8. Proposed Project Displaced Criteria Pollutant Emissions (Tons)						
Construction Year	Emissions (Tons)					
	ROG	NO_x	CO	SO₂	PM₁₀	PM_{2.5}
Emissions Displaced Annually (tons)						
Displaced Natural Gas-Source Emissions	0.00	1.07	0.32	0.74	1.02	0.41
Displaced Coal-Source Emissions	0.00	6.99	0.29	0.33	0.05	0.03
Total	0.00	8.06	0.62	1.07	1.07	0.45
Emissions Displaced over 30 Years (tons)						
Total	0	242	18	32	32	13

Source: Displaced emissions calculated by ECORP using USEPA's AP-42 Fifth Edition Compilation of Air Emissions Factors 1995; 2015.

Notes: In order to provide a conservative analysis, the proposed Project is assumed to generate electricity 25 percent of the time available (2,190 hours annually). Heat Rate indicates the energy generator efficiency of existing fossil-fuel based energy generators. The heat rate of a power plant measures the amount of fuel used to generate one unit of electricity. Power plants with lower heat rates are more efficient than plants with higher heat rates. The CEC's "Updated Thermal Power Plant Efficiency Measures and Operational Characteristics for Production Cost Modeling" (2019) estimates heat rates and operating ranges for thermal power plants supplying energy to California. The average heat rate of power plants types are as follows:

**Steam Boiler fueled by coal: 10,800 heat rate **Steam Boiler fueled by natural gas: 10,200 heat rate **Gas Turbine: 10,100 heat rate **Combined natural gas Boiler and Turbine: 7,640 heat rate.

By omitting steam boilers fueled by coal since so little of California's energy is derived from coal, the average heat rate = 9,313 $[(10,100 + 10,200 + 7,640) \div 3 = 9,313]$. 50 MW (109,500,000 annual KWh) x 9,313 heat rate = 1,019,773,500,000 Btu displaced from fossil fuel production. Fossil fuel-based energy consumption in California is predominately derived from natural gas (37.06 percent). Coal constitutes 2.74 percent of all fossil fuel-based energy. Therefore, 432,587,918,700 of the displaced Btu is displaced natural gas consumption and 27,941,793,900 is displaced Btu is displaced coal. The heat content of coal is assumed at 24 million Btu per ton of coal burned. At a rate of 24 million Btu per ton of coal burned, the Project would displace 1,164 tons of burned coal annually.

As shown, the Project would potentially displace approximately 242 tons of NO_x, 18 tons of CO, 32 tons of SO₂, 32 tons of PM₁₀, and 13 tons of PM_{2.5} over the course of 30 years. Furthermore, as demonstrated in Table 6 and Table 7, the Project would not exceed the applicable significance thresholds for construction or operational-source emissions.

2.3.3.4 Exposure of Sensitive Receptors to Toxic Air Contaminants

As previously described, sensitive receptors are defined as facilities or land uses that include members of the population that are particularly sensitive to the effects of air pollutants, such as children, the elderly, and people with illnesses. Examples of these sensitive receptors are residences, schools, hospitals, and daycare centers. CARB has identified the following groups of individuals as the most likely to be affected by air pollution: the elderly over age 65, children under age 14, athletes, and persons with cardiovascular

and chronic respiratory diseases such as asthma, emphysema, and bronchitis. The nearest existing noise-sensitive land use to the Project Site is a single-family residence located approximately 450 feet from the western boundary of the Project boundary.

Construction-Generated Air Contaminants

Construction of the Project would result in temporary, short-term proposed Project-generated emissions of diesel particulate matter (DPM), ROG, NO_x, CO, and PM₁₀ from the exhaust of off-road, heavy-duty diesel equipment for Project construction; soil hauling truck traffic; paving; and other miscellaneous activities. The portion of the SSAB which encompasses the Project Area is designated as a nonattainment area for federal O₃ and PM_{2.5} standards and is also a nonattainment area for the state standards for O₃ and PM₁₀ (CARB 2019). Thus, existing O₃ and PM₁₀ levels in the SSAB are at unhealthy levels during certain periods. However, as shown in Table 6, the Project would not exceed the ICAPCD significance thresholds for construction emissions.

The health effects associated with O₃ are generally associated with reduced lung function. Because the Project would not involve construction activities that would result in O₃ precursor emissions (ROG or NO_x) in excess of the ICAPCD thresholds, the Project is not anticipated to substantially contribute to regional O₃ concentrations and the associated health impacts.

CO tends to be a localized impact associated with congested intersections. In terms of adverse health effects, CO competes with oxygen, often replacing it in the blood, reducing the blood's ability to transport oxygen to vital organs. The results of excess CO exposure can include dizziness, fatigue, and impairment of central nervous system functions. The Project would not involve activities that would result in CO emissions in excess of the ICAPCD thresholds. Thus, the Project's CO emissions would not contribute to the health effects associated with this pollutant.

Particulate matter (PM₁₀ and PM_{2.5}) contains microscopic solids or liquid droplets that are so small that they can get deep into the lungs and cause serious health problems. Particulate matter exposure has been linked to a variety of problems, including premature death in people with heart or lung disease, nonfatal heart attacks, irregular heartbeat, aggravated asthma, decreased lung function, and increased respiratory symptoms such as irritation of the airways, coughing, or difficulty breathing. For construction-type activity, DPM is the primary TAC of concern. PM₁₀ exhaust is considered a surrogate for DPM as all diesel exhaust is considered to be DPM. Most PM₁₀ exhaust derives from combustion, such as use of gasoline and diesel fuels by motor vehicles. As with O₃ and NO_x, the Project would not generate emissions of PM₁₀ or PM_{2.5} that would exceed the ICAPCD's thresholds. Accordingly, the Project's PM₁₀ and PM_{2.5} emissions are not expected to cause any increase in related regional health effects for these pollutants.

In summary, Project construction would not result in a potentially significant contribution to regional concentrations of nonattainment pollutants and would not result in a significant contribution to the adverse health impacts associated with those pollutants.

Operational Air Contaminants

Operation of the Proposed Project would not result in the development of any substantial sources of air toxics. There would be no stationary sources associated with Project operations; nor would the Project attract additional mobile sources that spend long periods queuing and idling at the site. Onsite Project emissions would not result in significant concentrations of pollutants at the nearby sensitive receptor as the predominant operational emissions associated with the Proposed Project would be routine maintenance work, water deliveries, and site security. Therefore, the Project would not be a substantial source of TACs. The Project will not result in a high carcinogenic or non-carcinogenic risk during operation.

Carbon Monoxide Hot Spots

It has long been recognized that CO exceedances are caused by vehicular emissions, primarily when idling at intersections. Concentrations of CO are a direct function of the number of vehicles, length of delay, and traffic flow conditions. Under certain meteorological conditions, CO concentrations close to congested intersections that experience high levels of traffic and elevated background concentrations may reach unhealthy levels, affecting nearby sensitive receptors. Given the high traffic volume potential, areas of high CO concentrations, or "hot spots," are typically associated with intersections that are projected to operate at unacceptable levels of service during the peak commute hours. It has long been recognized that CO hotspots are caused by vehicular emissions, primarily when idling at congested intersections. However, transport of this criteria pollutant is extremely limited, and CO disperses rapidly with distance from the source under normal meteorological conditions. Furthermore, vehicle emissions standards have become increasingly stringent in the last 20 years. Currently, the allowable CO emissions standard in California is a maximum of 3.4 grams/mile for passenger cars (there are requirements for certain vehicles that are more stringent). With the turnover of older vehicles, introduction of cleaner fuels, and implementation of increasingly sophisticated and efficient emissions control technologies, CO concentration in the SSAB is designated as in attainment. Detailed modeling of Project-specific CO "hot spots" is not necessary and thus this potential impact is addressed qualitatively.

A CO "hot spot" would occur if an exceedance of the state one-hour standard of 20 parts per million (ppm) or the eight-hour standard of 9 ppm were to occur. The analysis prepared for CO attainment in the South Coast Air Quality Management District's (SCAQMD's) *1992 Federal Attainment Plan for Carbon Monoxide* in Los Angeles County and a Modeling and Attainment Demonstration prepared by the SCAQMD as part of the 2003 Air Quality Management Plan can be used to demonstrate the potential for CO exceedances of these standards. The SCAQMD is the air pollution control officer for much of southern California. The SCAQMD conducted a CO hot spot analysis as part of the 1992 CO Federal Attainment Plan at four busy intersections in Los Angeles County during the peak morning and afternoon time periods. The intersections evaluated included Long Beach Boulevard and Imperial Highway (Lynwood), Wilshire Boulevard and Veteran Avenue (Westwood), Sunset Boulevard and Highland Avenue (Hollywood), and La Cienega Boulevard and Century Boulevard (Inglewood). The busiest intersection evaluated was at Wilshire Boulevard and Veteran Avenue, which has a traffic volume of approximately 100,000 vehicles per day. Despite this level of traffic, the CO analysis concluded that there was no violation of CO standards (SCAQMD 1992). In order to establish a more accurate record of baseline CO concentrations affecting the

Los Angeles, a CO “hot spot” analysis was conducted in 2003 at the same four busy intersections in Los Angeles at the peak morning and afternoon time periods. This “hot spot” analysis did not predict any violation of CO standards. The highest one-hour concentration was measured at 4.6 ppm at Wilshire Boulevard and Veteran Avenue and the highest eight-hour concentration was measured at 8.4 ppm at Long Beach Boulevard and Imperial Highway. Thus, there was no violation of CO standards.

Similar considerations are also employed by other Air Districts when evaluating potential CO concentration impacts. More specifically, the Bay Area Air Quality Management District (BAAQMD), the air pollution control officer for the San Francisco Bay Area, concludes that under existing and future vehicle emission rates, a given project would have to increase traffic volumes at a single intersection by more than 44,000 vehicles per hour or 24,000 vehicles per hour where vertical and/or horizontal air does not mix—in order to generate a significant CO impact.

The Proposed Project is anticipated to result in no more than four daily traffic trips. It is noted that this is a conservative estimate and many days will have no operational related vehicle trips. Thus, the Proposed Project would not generate traffic volumes at any intersection of more than 100,000 vehicles per day (or 44,000 vehicles per day) and there is no likelihood of the Project traffic exceeding CO values.

2.3.3.5 Odors

Typically, odors are regarded as an annoyance rather than a health hazard. However, manifestations of a person’s reaction to foul odors can range from psychological (e.g., irritation, anger, or anxiety) to physiological (e.g., circulatory and respiratory effects, nausea, vomiting, and headache).

With respect to odors, the human nose is the sole sensing device. The ability to detect odors varies considerably among the population and overall is quite subjective. Some individuals have the ability to smell minute quantities of specific substances; others may not have the same sensitivity but may have sensitivities to odors of other substances. In addition, people may have different reactions to the same odor; in fact, an odor that is offensive to one person (e.g., from a fast-food restaurant) may be perfectly acceptable to another. It is also important to note that an unfamiliar odor is more easily detected and is more likely to cause complaints than a familiar one. This is because of the phenomenon known as odor fatigue, in which a person can become desensitized to almost any odor and recognition only occurs with an alteration in the intensity.

Quality and intensity are two properties present in any odor. The quality of an odor indicates the nature of the smell experience. For instance, if a person describes an odor as flowery or sweet, then the person is describing the quality of the odor. Intensity refers to the strength of the odor. For example, a person may use the word “strong” to describe the intensity of an odor. Odor intensity depends on the odorant concentration in the air. When an odorous sample is progressively diluted, the odorant concentration decreases. As this occurs, the odor intensity weakens and eventually becomes so low that the detection or recognition of the odor is quite difficult. At some point during dilution, the concentration of the odorant reaches a detection threshold. An odorant concentration below the detection threshold means that the concentration in the air is not detectable by the average human.

During construction, the Proposed Project presents the potential for generation of objectionable odors in the form of diesel exhaust in the immediate vicinity of the site. However, these emissions are short-term in nature and will rapidly dissipate and be diluted by the atmosphere downwind of the emission sources. Additionally, odors would be localized and generally confined to the Project Area, which is generally devoid of surrounding receptors. Therefore, odors generated during Project construction would not adversely affect a substantial number of people to odor emissions.

Land uses commonly considered to be potential sources of obnoxious odorous emissions include agriculture (farming and livestock), wastewater treatment plants, food processing plants, chemical plants, composting facilities, refineries, landfills, dairies, and fiberglass molding. The Proposed Project does not include any uses identified as being associated with odors.

3.0 GREENHOUSE GAS EMISSIONS

3.1 Greenhouse Gas Setting

Certain gases in the earth's atmosphere, classified as GHGs, play a critical role in determining the earth's surface temperature. Solar radiation enters the earth's atmosphere from space. A portion of the radiation is absorbed by the earth's surface and a smaller portion of this radiation is reflected back toward space. This absorbed radiation is then emitted from the earth as low-frequency infrared radiation. The frequencies at which bodies emit radiation are proportional to temperature. Because the earth has a much lower temperature than the sun, it emits lower-frequency radiation. Most solar radiation passes through GHGs; however, infrared radiation is absorbed by these gases. As a result, radiation that otherwise would have escaped back into space is instead trapped, resulting in a warming of the atmosphere. This phenomenon, known as the greenhouse effect, is responsible for maintaining a habitable climate on earth. Without the greenhouse effect, the earth would not be able to support life as we know it.

Prominent GHGs contributing to the greenhouse effect are CO₂, methane (CH₄), and N₂O. Fluorinated gases also make up a small fraction of the GHGs that contribute to climate change. Fluorinated gases include chlorofluorocarbons, hydrofluorocarbons, perfluorocarbons, sulfur hexafluoride, and nitrogen trifluoride; however, it is noted that these gases are not associated with typical land use development. Human-caused emissions of these GHGs in excess of natural ambient concentrations are believed to be responsible for intensifying the greenhouse effect and leading to a trend of unnatural warming of the earth's climate, known as global climate change or global warming. It is "extremely likely" that more than half of the observed increase in global average surface temperature from 1951 to 2010 was caused by the anthropogenic increase in GHG concentrations and other anthropogenic factors together (Intergovernmental Panel on Climate Change [IPCC] 2014).

Table 9 describes the primary GHGs attributed to global climate change, including their physical properties, primary sources, and contributions to the greenhouse effect.

Each GHG differs in its ability to absorb heat in the atmosphere based on the lifetime, or persistence, of the gas molecule in the atmosphere. CH₄ traps over 25 times more heat per molecule than CO₂, and N₂O absorbs 298 times more heat per molecule than CO₂ (IPCC 2014). Often, estimates of GHG emissions are

presented in carbon dioxide equivalents (CO₂e), which weight each gas by its global warming potential. Expressing GHG emissions in CO₂e takes the contribution of all GHG emissions to the greenhouse effect and converts them to a single unit equivalent to the effect that would occur if only CO₂ were being emitted.

Climate change is a global problem. GHGs are global pollutants, unlike criteria air pollutants and TACs, which are pollutants of regional and local concern. Whereas pollutants with localized air quality effects have relatively short atmospheric lifetimes (about one day), GHGs have long atmospheric lifetimes (one to several thousand years). GHGs persist in the atmosphere for long enough time periods to be dispersed around the globe. Although the exact lifetime of any particular GHG molecule is dependent on multiple variables and cannot be pinpointed, it is understood that more CO₂ is emitted into the atmosphere than is sequestered by ocean uptake, vegetation, or other forms. Of the total annual human-caused CO₂ emissions, approximately 55 percent is sequestered through ocean and land uptakes every year, averaged over the last 50 years, whereas the remaining 45 percent of human-caused CO₂ emissions remains stored in the atmosphere (IPCC 2013).

Table 9. Greenhouse Gases	
Greenhouse Gas	Description
CO ₂	Carbon dioxide is a colorless, odorless gas. CO ₂ is emitted in a number of ways, both naturally and through human activities. The largest source of CO ₂ emissions globally is the combustion of fossil fuels such as coal, oil, and gas in power plants, automobiles, industrial facilities, and other sources. A number of specialized industrial production processes and product uses such as mineral production, metal production, and the use of petroleum-based products can also lead to CO ₂ emissions. The atmospheric lifetime of CO ₂ is variable because it is so readily exchanged in the atmosphere. ¹
CH ₄	Methane is a colorless, odorless gas and is the major component of natural gas, about 87 percent by volume. It is also formed and released to the atmosphere by biological processes occurring in anaerobic environments. Methane is emitted from a variety of both human-related and natural sources. Human-related sources include fossil fuel production, animal husbandry (intestinal fermentation in livestock and manure management), rice cultivation, biomass burning, and waste management. These activities release significant quantities of CH ₄ to the atmosphere. Natural sources of CH ₄ include wetlands, gas hydrates, permafrost, termites, oceans, freshwater bodies, non-wetland soils, and other sources such as wildfires. The atmospheric lifetime of CH ₄ is about 12 years. ²
N ₂ O	Nitrous oxide is a clear, colorless gas with a slightly sweet odor. Nitrous oxide is produced by both natural and human-related sources. Primary human-related sources of N ₂ O are agricultural soil management, animal manure management, sewage treatment, mobile and stationary combustion of fossil fuels, adipic acid production, and nitric acid production. N ₂ O is also produced naturally from a wide variety of biological sources in soil and water, particularly microbial action in wet tropical forests. The atmospheric lifetime of N ₂ O is approximately 120 years. ³

Sources: ¹USEPA 2016a, ²USEPA 2016b, ³USEPA 2016c

The quantity of GHGs that it takes to ultimately result in climate change is not precisely known; it is sufficient to say the quantity is enormous, and no single project alone would measurably contribute to a

noticeable incremental change in the global average temperature or to global, local, or microclimates. From the standpoint of CEQA, GHG impacts to global climate change are inherently cumulative.

3.1.1 Sources of Greenhouse Gas Emissions

In 2021, CARB released the 2021 edition of the California GHG inventory covering calendar year 2019 emissions. In 2019, California emitted 418.2 million gross metric tons of CO₂e including from imported electricity. Combustion of fossil fuel in the transportation sector was the single largest source of California's GHG emissions in 2019, accounting for approximately 40 percent of total GHG emissions in the State. When emissions from extracting, refining and moving transportation fuels in California are included, transportation is responsible for over 50 percent of statewide emissions in 2019. Continuing the downward trend from 2018, transportation emissions decreased 3.5 million metric tons of CO₂e in 2019, only being outpaced by electricity, which reduced emissions by 4.3 million metric tons of CO₂e in 2019. Emissions from the electricity sector account for 14 percent of the inventory and have shown a substantial decrease in 2019 due to increases in renewables. California's industrial sector accounts for the second largest source of the State's GHG emissions in 2019, accounting for 21 percent (CARB 2021b).

3.2 Regulatory Framework

3.2.1 State

3.2.1.1 Executive Order S-3-05

Executive Order (EO) S-3-05, signed by Governor Arnold Schwarzenegger in 2005, proclaims that California is vulnerable to the impacts of climate change. It declares that increased temperatures could reduce the Sierra Nevada snowpack, further exacerbate California's air quality problems, and potentially cause a rise in sea levels. To combat those concerns, the EO established total GHG emission targets for the state. Specifically, emissions are to be reduced to the 2000 level by 2010, the 1990 level by 2020, and to 80 percent below the 1990 level by 2050.

3.2.1.2 Assembly Bill 32 Climate Change Scoping Plan and Updates

In 2006, the California legislature passed Assembly Bill (AB) 32 (Health and Safety Code § 38500 et seq., or AB 32), also known as the Global Warming Solutions Act. AB 32 required CARB to design and implement feasible and cost-effective emission limits, regulations, and other measures, such that statewide GHG emissions are reduced to 1990 levels by 2020 (representing a 25 percent reduction in emissions). Pursuant to AB 32, CARB adopted a Scoping Plan in December 2008, which outlined measures to meet the 2020 GHG reduction goals. California exceeded the target of reducing GHG emissions to 1990 levels by the year 2017.

The Scoping Plan is required by AB 32 to be updated at least every five years. The latest update, the 2017 Scoping Plan Update, addresses the 2030 target established by Senate Bill (SB) 32 as discussed below and establishes a proposed framework of action for California to meet a 40 percent reduction in GHG emissions by 2030 compared to 1990 levels. The key programs that the Scoping Plan Update builds on

include increasing the use of renewable energy in the State, the Cap-and-Trade Regulation, the Low Carbon Fuel Standard, and reduction of methane emissions from agricultural and other wastes.

3.2.1.3 Senate Bill 32 and Assembly Bill 197 of 2016

In August 2016, Governor Brown signed SB 32 and AB 197, which serve to extend California's GHG reduction programs beyond 2020. SB 32 amended the Health and Safety Code to include § 38566, which contains language to authorize CARB to achieve a statewide GHG emission reduction of at least 40 percent below 1990 levels by no later than December 31, 2030.

3.2.1.4 Senate Bill 100 of 2018

In 2018, SB 100 was signed by Governor Brown, codifying a goal of 60 percent renewable procurement by 2030 and 100 percent by 2045 Renewables Portfolio Standard.

3.3 Greenhouse Gas Emissions Impact Assessment

3.3.1 Thresholds of Significance

The impact analysis provided below is based on the following CEQA Guidelines Appendix G thresholds of significance. The Project would result in a significant impact to GHG emissions if it would:

1. Generate GHG emissions, either directly or indirectly, that may have a significant impact on the environment.
2. Conflict with any applicable plan, policy, or regulation of an agency adopted for the purpose of reducing the emissions of greenhouse gases.

The Appendix G thresholds for GHG's do not prescribe specific methodologies for performing an assessment, do not establish specific thresholds of significance, and do not mandate specific mitigation measures. Rather, the CEQA Guidelines emphasize the lead agency's discretion to determine the appropriate methodologies and thresholds of significance consistent with the manner in which other impact areas are handled in CEQA. With respect to GHG emissions, the CEQA Guidelines § 15064.4(a) states that lead agencies "shall make a good-faith effort, based to the extent possible on scientific and factual data, to describe, calculate or estimate" GHG emissions resulting from a project. The CEQA Guidelines note that an agency has the discretion to either quantify a project's GHG emissions or rely on a "qualitative analysis or other performance-based standards." (14 California Code of Regulations [CCR] 15064.4(b)). A lead agency may use a "model or methodology" to estimate GHG emissions and has the discretion to select the model or methodology it considers "most appropriate to enable decision makers to intelligently take into account the project's incremental contribution to climate change." (14 CCR 15064.4(c)). Section 15064.4(b) provides that the lead agency should consider the following when determining the significance of impacts from GHG emissions on the environment:

1. The extent a project may increase or reduce GHG emissions as compared to the existing environmental setting.

2. Whether the project emissions exceed a threshold of significance that the lead agency determines applies to the project.
3. The extent to which the project complies with regulations or requirements adopted to implement a statewide, regional, or local plan for the reduction or mitigation of GHG emissions (14 CCR 15064.4(b)).

In addition, Section 15064.7(c) of the CEQA Guidelines specifies that “[w]hen adopting or using thresholds of significance, a lead agency may consider thresholds of significance previously adopted or recommended by other public agencies, or recommended by experts, provided the decision of the lead agency to adopt such thresholds is supported by substantial evidence” (14 CCR 15064.7(c)). The CEQA Guidelines also clarify that the effects of GHG emissions are cumulative and should be analyzed in the context of CEQA’s requirements for cumulative impact analysis (see CEQA Guidelines § 15130(f)). As a note, the CEQA Guidelines were amended in response to SB 97. In particular, the CEQA Guidelines were amended to specify that compliance with a GHG emissions reduction plan renders a cumulative impact insignificant.

Per CEQA Guidelines § 15064(h)(3), a project’s incremental contribution to a cumulative impact can be found not cumulatively considerable if the project would comply with an approved plan or mitigation program that provides specific requirements that would avoid or substantially lessen the cumulative problem within the geographic area of the project. To qualify, such plans or programs must be specified in law or adopted by the public agency with jurisdiction over the affected resources through a public review process to implement, interpret, or make specific the law enforced or administered by the public agency. Examples of such programs include a “water quality control plan, air quality attainment or maintenance plan, integrated waste management plan, habitat conservation plan, natural community conservation plans [and] plans or regulations for the reduction of greenhouse gas emissions.” Put another way, CEQA Guidelines § 15064(h)(3) allows a lead agency to make a finding of less than significant for GHG emissions if a project complies with adopted programs, plans, policies and/or other regulatory strategies to reduce GHG emissions.

The significance of the Project’s GHG emissions is evaluated consistent with CEQA Guidelines § 15064.4(b)(2) by considering whether the Project complies with applicable plans, policies, regulations and requirements adopted to implement a statewide, regional, or local plan for the reduction or mitigation of GHG emissions. The ICAPCD has not adopted a GHG significance threshold yet recommends the 100,000-metric ton of CO₂e threshold established by the Mojave Desert Air Quality Management District (MDAQMD). As previously described, Section 15064.7(c) of the CEQA Guidelines specifies that “[w]hen adopting or using thresholds of significance, a lead agency may consider thresholds of significance previously adopted or recommended by other public agencies, or recommended by experts, provided the decision of the lead agency to adopt such thresholds is supported by substantial evidence” (14 CCR 15064.7(c)). This ICAPCD-recommended threshold is appropriate as the MDAQMD GHG thresholds were formulated based on similar geography and climate patterns as found in Imperial County. Therefore, the 100,000-metric ton of CO₂e threshold is appropriate for this analysis.

In *Center for Biological Diversity v. Department of Fish and Wildlife* (2015) 62 Cal. 4th 2014, 213, 221, 227, following its review of various potential GHG thresholds proposed in an academic study [Crockett, *Addressing the Significance of Greenhouse Gas Emissions: California's Search for Regulatory Certainty in an Uncertain World* (July 2011), 4 Golden Gate U. Env'tl. L. J. 203], the California Supreme Court identified the use of numeric bright-line thresholds as a potential pathway for compliance with CEQA GHG requirements. The study found numeric bright line thresholds designed to determine when small projects were so small as to not cause a cumulatively considerable impact on global climate change was consistent with CEQA. Specifically, Public Resources Code section 21003(f) provides it is a policy of the state that "[a]ll persons and public agencies involved in the environmental review process be responsible for carrying out the process in the most efficient, expeditious manner in order to conserve the available financial, governmental, physical and social resources with the objective that those resources may be better applied toward the mitigation of actual significant effects on the environment." The Supreme Court-reviewed study noted, "[s]ubjecting the smallest projects to the full panoply of CEQA requirements, even though the public benefit would be minimal, would not be consistent with implementing the statute in the most efficient, expeditious manner. Nor would it be consistent with applying lead agencies' scarce resources toward mitigating actual significant climate change impacts." (Crockett, *Addressing the Significance of Greenhouse Gas Emissions: California's Search for Regulatory Certainty in an Uncertain World* (July 2011), 4 Golden Gate U. Env'tl. L. J. 203, 221, 227.)

3.3.2 Methodology

Where GHG emission quantification was required, emissions were modeled using CalEEMod, version 2020.4.0. CalEEMod is a statewide land use emissions computer model designed to quantify potential GHG emissions associated with both construction and operations from a variety of land use projects. Project construction generated GHG emissions were calculated using CalEEMod model defaults for Imperial County. Operational GHG emissions were based on the Project Site plans.

3.3.3 Impact Analysis

3.3.3.1 Generation of GHG Emissions

Project Construction

Construction-related activities that would generate GHG emissions include worker commute trips, haul trucks carrying supplies and materials to and from the project site, and off-road construction equipment (e.g., dozers, loaders, excavators). Table 10 illustrates the specific construction generated GHG emissions that would result from construction of the Project. Consistent with SCAQMD recommendations, Project construction GHG emissions have been amortized over the expected life of the Project, which is considered to be 30 years for a solar energy generation facility. Once construction is complete, the generation of these GHG emissions would cease.

Table 10. Construction-Related Greenhouse Gas Emissions	
Emissions Source	CO₂e (Metric Tons/Year)
Construction Year One	1,064
Construction Year Two	351
<i>Significance Threshold</i>	<i>100,000</i>
Exceed Significance Threshold?	No

Source: CalEEMod version 2020.4.0. Refer to Appendix A for Model Data Outputs.

As shown in Table 10, Project would result in the generation of approximately 1,064 metric tons of CO₂e in the first year of construction and 351 metric tons in the second year of construction. Therefore, Project GHG emissions would not exceed the significance threshold.

Additionally, the Project proposes a solar energy generation facility intended to generate renewable energy. Solar plants generate far less GHG life-cycle emissions (approximately 83 to 94 percent less) than fossil-fueled energy plants. As identified in Table 13, the Project would potentially displace approximately 26,610 metric tons of CO₂e per year, and approximately 798,298 metric tons of CO₂e over the course of 30 years, which is considerably more than would be generated during construction.

Operations

Operation of the Project would result in an increase in GHG emissions solely associated with motor vehicle trips. Long-term GHG emissions attributed to operations of the Project are identified in Table 11.

Table 11. Operational-Related Greenhouse Gas Emissions	
Emission Source	CO₂e (Metric Tons/ Year)
Area Source	0
Energy	0
Mobile	63
Waste	0
Water	0
Total	63
Significance Threshold	<i>100,000</i>
Exceed Significance Threshold?	No

Source: CalEEMod version 2020.4.0. Refer to Appendix A for Model Data Outputs.

Notes: Operational emissions account for four heavy-duty truck vehicle trip per day. It is noted that this is a conservative estimate and many days will have no operational related vehicle trips.

As shown in Table 11, operational-generated emissions would not exceed the significance threshold of 100,000 metric tons of CO₂e annually.

3.3.3.2 Conflict with any Applicable Plan, Policy, or Regulation of an Agency Adopted for the Purpose of Reducing the Emissions of Greenhouse Gases

The Project would not conflict with any adopted plans, policies, or regulations adopted for the purpose of reducing GHG emissions. The Proposed Project is subject to compliance with SB 32. As discussed previously, the Proposed Project-generated GHG emissions would not surpass either the ICAPCD-recommended GHG significance threshold, which was prepared with the purpose of complying with statewide GHG-reduction efforts. Additionally, once construction is complete, the Project would be a producer of renewable energy, which generates substantially less GHG emissions compared with the more common types of fossil-fueled energy generation facilities.

GHG emissions generated by energy sources account for all stages of the life cycle (including mining, construction, etc.), which are referred to as the cumulative GHG emissions and are usually expressed in grams of CO₂e per unit of busbar electricity (i.e., gCO₂/kWh). When comparing various fossil-fueled energy generators, the GHG emissions generated are dependent on the type of fuel (i.e., gas, oil, coal). GHG emissions generated by some of the more common types of fossil-fueled plants and solar-power plants are summarized in Table 12.

Table 12. Life-Cycle Greenhouse Gas Emissions for Various Types of Energy Generators	
Fossil Fueled	
Coal	950 to 1,250 gCO ₂ e/kWhe
Oil	500 to 1,200 gCO ₂ e/kWhe
Gas	440 to 780 gCO ₂ e/kWhe
Solar	43 to 73 ³ gCO ₂ e/kWhe

Source: Weisser 2007

Notes:

1 gCO₂e/kWhe = grams of CO₂e per unit of busbar electricity.

2 Emissions are based on lifecycle of energy source including mining, construction, operation, etc.

3 Solar PV life-cycle emissions result from using fossil-fuel-based energy to produce the materials for solar cells, modules, and systems, as well as directly from smelting, production, and manufacturing facilities.

As shown in Table 124, solar plants generate far less GHG life-cycle emissions (approximately 83 to 94 percent less) than fossil-fueled energy plants. Therefore, the Proposed Project would contribute to the continued reduction of GHG emissions in the interconnected California and western U.S. electricity systems, as the energy produced by the Project would displace GHG emissions that would otherwise be produced by existing business-as-usual power generation resources (including natural gas, coal, arid renewable combustion resources).

Table 13 shows the emissions that would potentially be displaced by the Proposed Project. Note that this estimate only includes that associated with the combustion of fossil fuels; it does not include the vehicle trips associated with the Project's operations, and it similarly does not include operational employee trips associated with natural gas or coal combustion nor the emissions associated with extracting and transporting those power sources. In addition, this estimate only includes the displacement of that portion of the California market that comes from fossil fuels and does not include the approximate 50 percent of the California electricity generated by non-combustion sources (wind, solar, nuclear, hydro-electric) (CEC 2020).

Table 13. Proposed Project Displaced GHG Emissions (Metric Tons)				
	Emissions (Metric Tons)			
	CO₂	CH₄	N₂O	CO₂e
Emissions Displaced Annually (metric tons)				
Displaced Natural Gas-Source Emissions	23,792	0.00	0.00	23,792
Displaced Coal-Source Emissions	2,813	0.019	0.014	2,818
Total	26,605	0.019	0.014	26,610
Emissions Displaced over 30 Years (metric tons)				
Total	798,154	0.55	0.41	798,298

Source: Displaced emissions calculated by ECORP using USEPA's AP-42 Fifth Edition Compilation of Air Emissions Factors 1995; 2015.

Notes: In order to provide a conservative analysis, the proposed Project is assumed to generate electricity 25 percent of the time available (2,190 hours annually). Heat Rate indicates the energy generator efficiency of existing fossil-fuel based energy generators. The heat rate of a power plant measures the amount of fuel used to generate one unit of electricity. Power plants with lower heat rates are more efficient than plants with higher heat rates. The CEC's "Updated Thermal Power Plant Efficiency Measures and Operational Characteristics for Production Cost Modeling" (2019) estimates heat rates and operating ranges for thermal power plants supplying energy to California. The average heat rate of power plants types are as follows:

**Steam Boiler fueled by coal: 10,800 heat rate **Steam Boiler fueled by natural gas: 10,200 heat rate **Gas Turbine: 10,100 heat rate **Combined natural gas Boiler and Turbine: 7,640 heat rate.

By omitting steam boilers fueled by coal since so little of California's energy is derived from coal, the average heat rate = 9,313 [(10,100 + 10,200 + 7,640) ÷ 3 = 9,313]. 50 MW (109,500,000 annual KWh) x 9,313 heat rate = 1,019,773,500,000 Btu displaced from fossil fuel production. Fossil fuel-based energy consumption in California is predominately derived from natural gas (37.06 percent). Coal constitutes 2.74 percent of all fossil fuel-based energy. Therefore, 432,587,918,700 of the displaced Btu is displaced natural gas consumption and 27,941,793,900 is displaced Btu is displaced coal. The heat content of coal is assumed at 24 million Btu per ton of coal burned. At a rate of 24 million Btu per ton of coal burned, the Project would displace 1,164 tons of burned coal annually.

As shown, the Project would potentially displace approximately 26,605 metric tons of CO₂e per year, and approximately 798,154 metric tons of CO₂e over the course of 30 years.

While the Project would emit some GHG emissions during construction and a very small amount during operations, the contribution of renewable resource energy production to meet the goals of the

Renewable Portfolio Standard (Scoping Plan Measure E-3) would result in a net cumulative reduction of GHG emissions, a key environmental benefit. (Scoping Plan Measure E-3, Renewable Portfolio Standard, of the Climate Change Scoping Plan requires that all investor-owned utility companies generate 60 percent of their energy demand from renewable sources by year 2030.) Therefore, the short-term minor generation of GHG emissions during construction, which is necessary to create this new, low-GHG-emitting power-generating facility, as well as the negligible amount generated during ongoing maintenance operations, would be more than offset by GHG emission reductions associated with solar-generated energy during operation.

Increasing sources of solar energy is one of the measures identified under the Scoping Plan to reduce statewide GHG emissions. The Proposed Project would reduce GHG emissions in a manner consistent with SB 32 and other California GHG-reducing legislation by creating a new source of solar power to replace the current use of fossil-fuel power and reduce GHG emissions power generation and use.

The Project would not conflict with any applicable plan, policy, or regulation intended to reduce GHG emissions.

4.0 REFERENCES

- California Air Pollution Control Officers Association (CAPCOA). 2021. California Emissions Estimator Model (CalEEMod), version 2020.4.0.
- _____. 2013. Health Effects. <http://www.capcoa.org/health-effects/>.
- California Air Resources Board (CARB). 2021a. Air Quality Data Statistics. <http://www.arb.ca.gov/adam/index.html>.
- _____. 2021b. California Greenhouse Gas Emission Inventory 2021 Edition. <https://ww2.arb.ca.gov/ghg-inventory-data>
- _____. 2020b. Air Quality and Land Use Handbook
- _____. 2019. State and Federal Area Designation Maps. <http://www.arb.ca.gov/desig/adm/adm.htm>.
- California Energy Commission (CEC). 2020. 2020 Total System Electric Generation. <https://www.energy.ca.gov/data-reports/energy-almanac/california-electricity-data/2020-total-system-electric-generation>
- _____. 2019b. Updated Thermal Power Plant Efficiency Measures and Operational Characteristics for Production Cost Modeling.
- Crockett, Alexander G. 2011. Addressing the Significance of Greenhouse Gas Emissions Under CEQA: California's Search for Regulatory Certainty in an Uncertain World.
- Intergovernmental Panel on Climate Change (IPCC). 2014. Climate Change 2014 Synthesis Report: Approved Summary for Policymakers. <http://www.ipcc.ch/>.
- _____. 2013. Carbon and Other Biogeochemical Cycles. In: Climate Change 2013: The Physical Science Basis. Contribution of Working Group I to the Fifth Assessment Report of the Intergovernmental Panel on Climate Change. http://www.climatechange2013.org/images/report/WG1AR5_ALL_FINAL.pdf.
- Imperial County Air Pollution Control District (ICAPCD). 2017. *Air Quality Handbook*.
- _____. 2010. *Final 2009 1997 8-Hour Ozone Modified Air Quality Management Plan*.
- South Coast Air Quality Management District (SCAQMD). 2003. Air Quality Management Plan.
- _____. 1992. 1992 Federal Attainment Plan for Carbon Monoxide.
- U.S. Environmental Protection Agency (USEPA). 2016a. Climate Change – Greenhouse Gas Emissions: Carbon Dioxide. <http://www.epa.gov/climatechange/emissions/co2.html>.
- _____. 2016b. Methane. <https://www3.epa.gov/climatechange/ghgemissions/gases/ch4.html>.
- _____. 2016c. Nitrous Oxide. <https://www3.epa.gov/climatechange/ghgemissions/gases/n2o.html>.
- _____. 2002. Health Assessment Document for Diesel Engine Exhaust. <https://nepis.epa.gov/Exe/ZyPURL.cgi?Dockey=300055PV.TXT>.

Weisser, Daniel. 2007. A Guide to Life-Cycle Greenhouse Gas (GHG) Emissions from Electric Supply Technologies. *Energy* 32 (9), 1543–1559.

LIST OF APPENDICES

Appendix A – CalEEMod Output Files Criteria Air Pollutants & Greenhouse Gas Emissions

Appendix B – Renewable Energy Emissions Displacement

CalEEMod Output Files Criteria Air Pollutants & Greenhouse Gas Emissions

Northstar #1 Project - UNMITIGATED - Imperial County, Summer

EMFAC Off-Model Adjustment Factors for Gasoline Light Duty Vehicle to Account for the SAFE Vehicle Rule Not Applied

Northstar #1 Project - UNMITIGATED
Imperial County, Summer

1.0 Project Characteristics

1.1 Land Usage

Land Uses	Size	Metric	Lot Acreage	Floor Surface Area	Population
Other Non-Asphalt Surfaces	287.00	Acre	287.00	12,501,720.00	0

1.2 Other Project Characteristics

Urbanization	Rural	Wind Speed (m/s)	3.4	Precipitation Freq (Days)	12
Climate Zone	15			Operational Year	2024
Utility Company	Imperial Irrigation District				
CO2 Intensity (lb/MW hr)	189.98	CH4 Intensity (lb/MW hr)	0.033	N2O Intensity (lb/MW hr)	0.004

1.3 User Entered Comments & Non-Default Data

Project Characteristics -

Land Use -

Construction Phase - Days of construction based on previous Z Global solar generation facility projects in Imperial County

Off-road Equipment - Equipment derived from previous Z Global solar generation facilities in Imperial County

Off-road Equipment - Ibid

Off-road Equipment - Ibid

Grading -

Construction Off-road Equipment Mitigation - ICAPCD Regulation VIII applied.

Vehicle Trips - Assume 4 heavy duty trucks trips daily

Trips and VMT - Maximum 75 workers assumed. Commute miles derived from an averaged distance between the Project Site and Brawley and the Project Site and Palm Springs [47 miles]

On-road Fugitive Dust - 1.15 miles of Project access is unpaved. Equates to 2.4 percent of 47 mile route.

Northstar #1 Project - UNMITIGATED - Imperial County, Summer

EMFAC Off-Model Adjustment Factors for Gasoline Light Duty Vehicle to Account for the SAFE Vehicle Rule Not Applied

Road Dust - 1.15 miles of site access unpaved. Equates to 2.4 percent of the route

Fleet Mix - Assume 100% heavy duty truck fleet mix

Table Name	Column Name	Default Value	New Value
tblConstructionPhase	NumDays	4,650.00	85.00
tblConstructionPhase	NumDays	465.00	120.00
tblConstructionPhase	NumDays	180.00	60.00
tblConstructionPhase	PhaseEndDate	10/22/2043	3/5/2024
tblConstructionPhase	PhaseEndDate	12/25/2025	11/7/2023
tblConstructionPhase	PhaseEndDate	3/14/2024	5/23/2023
tblConstructionPhase	PhaseStartDate	12/26/2025	11/8/2023
tblConstructionPhase	PhaseStartDate	3/15/2024	5/24/2023
tblConstructionPhase	PhaseStartDate	7/7/2023	3/1/2023
tblFleetMix	HHD	0.02	1.00
tblFleetMix	LDA	0.53	0.00
tblFleetMix	LDT1	0.06	0.00
tblFleetMix	LDT2	0.18	0.00
tblFleetMix	LHD1	0.03	0.00
tblFleetMix	LHD2	6.8510e-003	0.00
tblFleetMix	MCY	0.02	0.00
tblFleetMix	MDV	0.15	0.00
tblFleetMix	MH	3.5040e-003	0.00
tblFleetMix	MHD	8.3160e-003	0.00
tblFleetMix	OBUS	9.2500e-004	0.00
tblFleetMix	SBUS	7.6600e-004	0.00
tblFleetMix	UBUS	1.2000e-004	0.00
tblOffRoadEquipment	LoadFactor	0.38	0.38
tblOffRoadEquipment	LoadFactor	0.38	0.38
tblOffRoadEquipment	LoadFactor	0.38	0.38
tblOffRoadEquipment	LoadFactor	0.42	0.42

Northstar #1 Project - UNMITIGATED - Imperial County, Summer

EMFAC Off-Model Adjustment Factors for Gasoline Light Duty Vehicle to Account for the SAFE Vehicle Rule Not Applied

tblOffRoadEquipment	LoadFactor	0.36	0.36
tblOffRoadEquipment	LoadFactor	0.38	0.38
tblOffRoadEquipment	LoadFactor	0.40	0.40
tblOffRoadEquipment	LoadFactor	0.50	0.50
tblOffRoadEquipment	OffRoadEquipmentType		Off-Highway Trucks
tblOffRoadEquipment	OffRoadEquipmentType		Off-Highway Trucks
tblOffRoadEquipment	OffRoadEquipmentType		Off-Highway Trucks
tblOffRoadEquipment	OffRoadEquipmentType		Pavers
tblOffRoadEquipment	OffRoadEquipmentType		Paving Equipment
tblOffRoadEquipment	OffRoadEquipmentType		Plate Compactors
tblOffRoadEquipment	OffRoadEquipmentType		Rollers
tblOffRoadEquipment	OffRoadEquipmentType		Rough Terrain Forklifts
tblOffRoadEquipment	OffRoadEquipmentType		Trenchers
tblOffRoadEquipment	OffRoadEquipmentUnitAmount	2.00	4.00
tblOffRoadEquipment	OffRoadEquipmentUnitAmount	3.00	0.00
tblOffRoadEquipment	OffRoadEquipmentUnitAmount	1.00	0.00
tblOffRoadEquipment	OffRoadEquipmentUnitAmount	1.00	3.00
tblOffRoadEquipment	OffRoadEquipmentUnitAmount	1.00	2.00
tblOffRoadEquipment	OffRoadEquipmentUnitAmount	3.00	2.00
tblOffRoadEquipment	OffRoadEquipmentUnitAmount	3.00	4.00
tblOffRoadEquipment	OffRoadEquipmentUnitAmount	2.00	4.00
tblOffRoadEquipment	OffRoadEquipmentUnitAmount	4.00	2.00
tblOnRoadDust	VendorPercentPave	50.00	97.60
tblOnRoadDust	WorkerPercentPave	50.00	97.60
tblOnRoadDust	WorkerPercentPave	50.00	97.60
tblOnRoadDust	WorkerPercentPave	50.00	97.60
tblProjectCharacteristics	UrbanizationLevel	Urban	Rural
tblRoadDust	RoadPercentPave	50	97.6
tblTripsAndVMT	VendorTripLength	11.90	47.00

Northstar #1 Project - UNMITIGATED - Imperial County, Summer

EMFAC Off-Model Adjustment Factors for Gasoline Light Duty Vehicle to Account for the SAFE Vehicle Rule Not Applied

tblTripsAndVMT	VendorTripNumber	2,049.00	10.00
tblTripsAndVMT	WorkerTripLength	10.20	47.00
tblTripsAndVMT	WorkerTripLength	10.20	47.00
tblTripsAndVMT	WorkerTripLength	10.20	47.00
tblTripsAndVMT	WorkerTripNumber	5,251.00	150.00
tblVehicleTrips	CC_TL	9.50	47.00
tblVehicleTrips	CC_TTP	0.00	100.00
tblVehicleTrips	CNW_TL	11.90	47.00
tblVehicleTrips	CW_TL	16.40	47.00
tblVehicleTrips	PR_TP	0.00	100.00
tblVehicleTrips	WD_TR	0.00	0.01

2.0 Emissions Summary

Northstar #1 Project - UNMITIGATED - Imperial County, Summer

EMFAC Off-Model Adjustment Factors for Gasoline Light Duty Vehicle to Account for the SAFE Vehicle Rule Not Applied

2.1 Overall Construction (Maximum Daily Emission)

Unmitigated Construction

	ROG	NOx	CO	SO2	Fugitive PM10	Exhaust PM10	PM10 Total	Fugitive PM2.5	Exhaust PM2.5	PM2.5 Total	Bio- CO2	NBio- CO2	Total CO2	CH4	N2O	CO2e
Year	lb/day										lb/day					
2023	7.2912	61.0501	72.8382	0.1721	271.2819	2.4862	273.3904	28.0207	2.2873	29.9687	0.0000	16,867.97 12	16,867.97 12	3.5860	0.2729	17,036.91 01
2024	7.0003	45.9154	70.8788	0.1705	271.2819	1.9571	273.2390	28.0207	1.8082	29.8289	0.0000	16,706.02 58	16,706.02 58	3.4932	0.2605	16,870.97 15
Maximum	7.2912	61.0501	72.8382	0.1721	271.2819	2.4862	273.3904	28.0207	2.2873	29.9687	0.0000	16,867.97 12	16,867.97 12	3.5860	0.2729	17,036.91 01

Mitigated Construction

	ROG	NOx	CO	SO2	Fugitive PM10	Exhaust PM10	PM10 Total	Fugitive PM2.5	Exhaust PM2.5	PM2.5 Total	Bio- CO2	NBio- CO2	Total CO2	CH4	N2O	CO2e
Year	lb/day										lb/day					
2023	7.2912	61.0501	72.8382	0.1721	271.2819	2.4862	273.3904	28.0207	2.2873	29.9687	0.0000	16,867.97 12	16,867.97 12	3.5860	0.2729	17,036.91 01
2024	7.0003	45.9154	70.8788	0.1705	271.2819	1.9571	273.2390	28.0207	1.8082	29.8289	0.0000	16,706.02 57	16,706.02 57	3.4932	0.2605	16,870.97 15
Maximum	7.2912	61.0501	72.8382	0.1721	271.2819	2.4862	273.3904	28.0207	2.2873	29.9687	0.0000	16,867.97 12	16,867.97 12	3.5860	0.2729	17,036.91 01

Northstar #1 Project - UNMITIGATED - Imperial County, Summer

EMFAC Off-Model Adjustment Factors for Gasoline Light Duty Vehicle to Account for the SAFE Vehicle Rule Not Applied

2.2 Overall Operational

Unmitigated Operational

	ROG	NOx	CO	SO2	Fugitive PM10	Exhaust PM10	PM10 Total	Fugitive PM2.5	Exhaust PM2.5	PM2.5 Total	Bio- CO2	NBio- CO2	Total CO2	CH4	N2O	CO2e
Category	lb/day										lb/day					
Area	5.8596	2.7000e-004	0.0293	0.0000		1.0000e-004	1.0000e-004		1.0000e-004	1.0000e-004		0.0628	0.0628	1.6000e-004		0.0669
Energy	0.0000	0.0000	0.0000	0.0000		0.0000	0.0000		0.0000	0.0000		0.0000	0.0000	0.0000	0.0000	0.0000
Mobile	0.0138	0.7763	0.1503	4.8000e-003	3.5357	0.0114	3.5470	0.3805	0.0109	0.3914		508.9185	508.9185	1.1100e-003	0.0800	532.7858
Total	5.8734	0.7766	0.1795	4.8000e-003	3.5357	0.0115	3.5471	0.3805	0.0110	0.3915		508.9814	508.9814	1.2700e-003	0.0800	532.8527

Mitigated Operational

	ROG	NOx	CO	SO2	Fugitive PM10	Exhaust PM10	PM10 Total	Fugitive PM2.5	Exhaust PM2.5	PM2.5 Total	Bio- CO2	NBio- CO2	Total CO2	CH4	N2O	CO2e
Category	lb/day										lb/day					
Area	5.8596	2.7000e-004	0.0293	0.0000		1.0000e-004	1.0000e-004		1.0000e-004	1.0000e-004		0.0628	0.0628	1.6000e-004		0.0669
Energy	0.0000	0.0000	0.0000	0.0000		0.0000	0.0000		0.0000	0.0000		0.0000	0.0000	0.0000	0.0000	0.0000
Mobile	0.0138	0.7763	0.1503	4.8000e-003	3.5357	0.0114	3.5470	0.3805	0.0109	0.3914		508.9185	508.9185	1.1100e-003	0.0800	532.7858
Total	5.8734	0.7766	0.1795	4.8000e-003	3.5357	0.0115	3.5471	0.3805	0.0110	0.3915		508.9814	508.9814	1.2700e-003	0.0800	532.8527

Northstar #1 Project - UNMITIGATED - Imperial County, Summer

EMFAC Off-Model Adjustment Factors for Gasoline Light Duty Vehicle to Account for the SAFE Vehicle Rule Not Applied

	ROG	NOx	CO	SO2	Fugitive PM10	Exhaust PM10	PM10 Total	Fugitive PM2.5	Exhaust PM2.5	PM2.5 Total	Bio- CO2	NBio-CO2	Total CO2	CH4	N2O	CO2e
Percent Reduction	0.00	0.00	0.00	0.00	0.00	0.00	0.00	0.00	0.00	0.00	0.00	0.00	0.00	0.00	0.00	0.00

3.0 Construction Detail

Construction Phase

Phase Number	Phase Name	Phase Type	Start Date	End Date	Num Days Week	Num Days	Phase Description
1	Site Preparation	Site Preparation	3/1/2023	5/23/2023	5	60	
2	Grading	Grading	5/24/2023	11/7/2023	5	120	
3	Building Construction	Building Construction	11/8/2023	3/5/2024	5	85	

Acres of Grading (Site Preparation Phase): 60

Acres of Grading (Grading Phase): 540

Acres of Paving: 287

Residential Indoor: 0; Residential Outdoor: 0; Non-Residential Indoor: 0; Non-Residential Outdoor: 0; Striped Parking Area: 0 (Architectural Coating – sqft)

OffRoad Equipment

Phase Name	Offroad Equipment Type	Amount	Usage Hours	Horse Power	Load Factor
Site Preparation	Off-Highway Trucks	1	8.00	402	0.38
Grading	Off-Highway Trucks	1	8.00	402	0.38
Building Construction	Cranes	1	7.00	231	0.29
Building Construction	Off-Highway Trucks	4	8.00	402	0.38
Grading	Excavators	4	8.00	158	0.38
Building Construction	Forklifts	0	8.00	89	0.20
Building Construction	Generator Sets	0	8.00	84	0.74
Grading	Graders	3	8.00	187	0.41

Northstar #1 Project - UNMITIGATED - Imperial County, Summer

EMFAC Off-Model Adjustment Factors for Gasoline Light Duty Vehicle to Account for the SAFE Vehicle Rule Not Applied

Building Construction	Pavers	1	8.00	130	0.42
Building Construction	Paving Equipment	2	8.00	132	0.36
Building Construction	Plate Compactors	4	8.00	8	0.43
Building Construction	Rollers	2	8.00	80	0.38
Grading	Rubber Tired Dozers	2	8.00	247	0.40
Site Preparation	Rubber Tired Dozers	2	8.00	247	0.40
Grading	Scrapers	2	8.00	367	0.48
Building Construction	Tractors/Loaders/Backhoes	4	7.00	97	0.37
Grading	Tractors/Loaders/Backhoes	4	8.00	97	0.37
Site Preparation	Tractors/Loaders/Backhoes	2	8.00	97	0.37
Building Construction	Welders	1	8.00	46	0.45
Building Construction	Rough Terrain Forklifts	4	8.00	100	0.40
Building Construction	Trenchers	2	8.00	78	0.50

Trips and VMT

Phase Name	Offroad Equipment Count	Worker Trip Number	Vendor Trip Number	Hauling Trip Number	Worker Trip Length	Vendor Trip Length	Hauling Trip Length	Worker Vehicle Class	Vendor Vehicle Class	Hauling Vehicle Class
Site Preparation	5	13.00	0.00	0.00	47.00	11.90	20.00	LD_Mix	HDT_Mix	HHDT
Grading	16	40.00	0.00	0.00	47.00	11.90	20.00	LD_Mix	HDT_Mix	HHDT
Building Construction	25	150.00	10.00	0.00	47.00	47.00	20.00	LD_Mix	HDT_Mix	HHDT

3.1 Mitigation Measures Construction

Water Exposed Area

Reduce Vehicle Speed on Unpaved Roads

Northstar #1 Project - UNMITIGATED - Imperial County, Summer

EMFAC Off-Model Adjustment Factors for Gasoline Light Duty Vehicle to Account for the SAFE Vehicle Rule Not Applied

3.2 Site Preparation - 2023

Unmitigated Construction On-Site

	ROG	NOx	CO	SO2	Fugitive PM10	Exhaust PM10	PM10 Total	Fugitive PM2.5	Exhaust PM2.5	PM2.5 Total	Bio- CO2	NBio- CO2	Total CO2	CH4	N2O	CO2e
Category	lb/day										lb/day					
Fugitive Dust					13.1047	0.0000	13.1047	6.7350	0.0000	6.7350			0.0000			0.0000
Off-Road	2.1784	20.9114	13.9803	0.0366		0.9231	0.9231		0.8493	0.8493		3,543.4424	3,543.4424	1.1460		3,572.0929
Total	2.1784	20.9114	13.9803	0.0366	13.1047	0.9231	14.0278	6.7350	0.8493	7.5842		3,543.4424	3,543.4424	1.1460		3,572.0929

Unmitigated Construction Off-Site

	ROG	NOx	CO	SO2	Fugitive PM10	Exhaust PM10	PM10 Total	Fugitive PM2.5	Exhaust PM2.5	PM2.5 Total	Bio- CO2	NBio- CO2	Total CO2	CH4	N2O	CO2e
Category	lb/day										lb/day					
Hauling	0.0000	0.0000	0.0000	0.0000	0.0000	0.0000	0.0000	0.0000	0.0000	0.0000		0.0000	0.0000	0.0000	0.0000	0.0000
Vendor	0.0000	0.0000	0.0000	0.0000	0.0000	0.0000	0.0000	0.0000	0.0000	0.0000		0.0000	0.0000	0.0000	0.0000	0.0000
Worker	0.1728	0.1128	1.8467	4.2300e-003	22.0353	2.0700e-003	22.0374	2.2742	1.9100e-003	2.2761		427.1074	427.1074	8.1900e-003	9.7600e-003	430.2211
Total	0.1728	0.1128	1.8467	4.2300e-003	22.0353	2.0700e-003	22.0374	2.2742	1.9100e-003	2.2761		427.1074	427.1074	8.1900e-003	9.7600e-003	430.2211

Northstar #1 Project - UNMITIGATED - Imperial County, Summer

EMFAC Off-Model Adjustment Factors for Gasoline Light Duty Vehicle to Account for the SAFE Vehicle Rule Not Applied

3.2 Site Preparation - 2023

Mitigated Construction On-Site

	ROG	NOx	CO	SO2	Fugitive PM10	Exhaust PM10	PM10 Total	Fugitive PM2.5	Exhaust PM2.5	PM2.5 Total	Bio- CO2	NBio- CO2	Total CO2	CH4	N2O	CO2e
Category	lb/day										lb/day					
Fugitive Dust					5.8971	0.0000	5.8971	3.0307	0.0000	3.0307			0.0000			0.0000
Off-Road	2.1784	20.9114	13.9803	0.0366		0.9231	0.9231		0.8493	0.8493	0.0000	3,543.442 3	3,543.442 3	1.1460		3,572.092 9
Total	2.1784	20.9114	13.9803	0.0366	5.8971	0.9231	6.8202	3.0307	0.8493	3.8800	0.0000	3,543.442 3	3,543.442 3	1.1460		3,572.092 9

Mitigated Construction Off-Site

	ROG	NOx	CO	SO2	Fugitive PM10	Exhaust PM10	PM10 Total	Fugitive PM2.5	Exhaust PM2.5	PM2.5 Total	Bio- CO2	NBio- CO2	Total CO2	CH4	N2O	CO2e
Category	lb/day										lb/day					
Hauling	0.0000	0.0000	0.0000	0.0000	0.0000	0.0000	0.0000	0.0000	0.0000	0.0000		0.0000	0.0000	0.0000	0.0000	0.0000
Vendor	0.0000	0.0000	0.0000	0.0000	0.0000	0.0000	0.0000	0.0000	0.0000	0.0000		0.0000	0.0000	0.0000	0.0000	0.0000
Worker	0.1728	0.1128	1.8467	4.2300e-003	22.0353	2.0700e-003	22.0374	2.2742	1.9100e-003	2.2761		427.1074	427.1074	8.1900e-003	9.7600e-003	430.2211
Total	0.1728	0.1128	1.8467	4.2300e-003	22.0353	2.0700e-003	22.0374	2.2742	1.9100e-003	2.2761		427.1074	427.1074	8.1900e-003	9.7600e-003	430.2211

Northstar #1 Project - UNMITIGATED - Imperial County, Summer

EMFAC Off-Model Adjustment Factors for Gasoline Light Duty Vehicle to Account for the SAFE Vehicle Rule Not Applied

3.3 Grading - 2023

Unmitigated Construction On-Site

	ROG	NOx	CO	SO2	Fugitive PM10	Exhaust PM10	PM10 Total	Fugitive PM2.5	Exhaust PM2.5	PM2.5 Total	Bio- CO2	NBio- CO2	Total CO2	CH4	N2O	CO2e
Category	lb/day										lb/day					
Fugitive Dust					16.8164	0.0000	16.8164	7.1358	0.0000	7.1358			0.0000			0.0000
Off-Road	5.9598	60.7032	48.8259	0.1137		2.4798	2.4798		2.2814	2.2814		11,009.84 10	11,009.84 10	3.5608		11,098.86 11
Total	5.9598	60.7032	48.8259	0.1137	16.8164	2.4798	19.2962	7.1358	2.2814	9.4172		11,009.84 10	11,009.84 10	3.5608		11,098.86 11

Unmitigated Construction Off-Site

	ROG	NOx	CO	SO2	Fugitive PM10	Exhaust PM10	PM10 Total	Fugitive PM2.5	Exhaust PM2.5	PM2.5 Total	Bio- CO2	NBio- CO2	Total CO2	CH4	N2O	CO2e
Category	lb/day										lb/day					
Hauling	0.0000	0.0000	0.0000	0.0000	0.0000	0.0000	0.0000	0.0000	0.0000	0.0000		0.0000	0.0000	0.0000	0.0000	0.0000
Vendor	0.0000	0.0000	0.0000	0.0000	0.0000	0.0000	0.0000	0.0000	0.0000	0.0000		0.0000	0.0000	0.0000	0.0000	0.0000
Worker	0.5316	0.3470	5.6822	0.0130	67.8010	6.3800e-003	67.8073	6.9975	5.8700e-003	7.0034		1,314.176 6	1,314.176 6	0.0252	0.0300	1,323.757 3
Total	0.5316	0.3470	5.6822	0.0130	67.8010	6.3800e-003	67.8073	6.9975	5.8700e-003	7.0034		1,314.176 6	1,314.176 6	0.0252	0.0300	1,323.757 3

Northstar #1 Project - UNMITIGATED - Imperial County, Summer

EMFAC Off-Model Adjustment Factors for Gasoline Light Duty Vehicle to Account for the SAFE Vehicle Rule Not Applied

3.3 Grading - 2023

Mitigated Construction On-Site

	ROG	NOx	CO	SO2	Fugitive PM10	Exhaust PM10	PM10 Total	Fugitive PM2.5	Exhaust PM2.5	PM2.5 Total	Bio- CO2	NBio- CO2	Total CO2	CH4	N2O	CO2e
Category	lb/day										lb/day					
Fugitive Dust					7.5674	0.0000	7.5674	3.2111	0.0000	3.2111			0.0000			0.0000
Off-Road	5.9598	60.7032	48.8259	0.1137		2.4798	2.4798		2.2814	2.2814	0.0000	11,009.84 10	11,009.84 10	3.5608		11,098.86 11
Total	5.9598	60.7032	48.8259	0.1137	7.5674	2.4798	10.0472	3.2111	2.2814	5.4925	0.0000	11,009.84 10	11,009.84 10	3.5608		11,098.86 11

Mitigated Construction Off-Site

	ROG	NOx	CO	SO2	Fugitive PM10	Exhaust PM10	PM10 Total	Fugitive PM2.5	Exhaust PM2.5	PM2.5 Total	Bio- CO2	NBio- CO2	Total CO2	CH4	N2O	CO2e
Category	lb/day										lb/day					
Hauling	0.0000	0.0000	0.0000	0.0000	0.0000	0.0000	0.0000	0.0000	0.0000	0.0000		0.0000	0.0000	0.0000	0.0000	0.0000
Vendor	0.0000	0.0000	0.0000	0.0000	0.0000	0.0000	0.0000	0.0000	0.0000	0.0000		0.0000	0.0000	0.0000	0.0000	0.0000
Worker	0.5316	0.3470	5.6822	0.0130	67.8010	6.3800e-003	67.8073	6.9975	5.8700e-003	7.0034		1,314.176 6	1,314.176 6	0.0252	0.0300	1,323.757 3
Total	0.5316	0.3470	5.6822	0.0130	67.8010	6.3800e-003	67.8073	6.9975	5.8700e-003	7.0034		1,314.176 6	1,314.176 6	0.0252	0.0300	1,323.757 3

Northstar #1 Project - UNMITIGATED - Imperial County, Summer

EMFAC Off-Model Adjustment Factors for Gasoline Light Duty Vehicle to Account for the SAFE Vehicle Rule Not Applied

3.4 Building Construction - 2023

Unmitigated Construction On-Site

	ROG	NOx	CO	SO2	Fugitive PM10	Exhaust PM10	PM10 Total	Fugitive PM2.5	Exhaust PM2.5	PM2.5 Total	Bio- CO2	NBio- CO2	Total CO2	CH4	N2O	CO2e
Category	lb/day										lb/day					
Off-Road	5.2299	45.8103	51.1124	0.1121		2.0654	2.0654		1.9077	1.9077		10,764.8165	10,764.8165	3.4068		10,849.9866
Total	5.2299	45.8103	51.1124	0.1121		2.0654	2.0654		1.9077	1.9077		10,764.8165	10,764.8165	3.4068		10,849.9866

Unmitigated Construction Off-Site

	ROG	NOx	CO	SO2	Fugitive PM10	Exhaust PM10	PM10 Total	Fugitive PM2.5	Exhaust PM2.5	PM2.5 Total	Bio- CO2	NBio- CO2	Total CO2	CH4	N2O	CO2e
Category	lb/day										lb/day					
Hauling	0.0000	0.0000	0.0000	0.0000	0.0000	0.0000	0.0000	0.0000	0.0000	0.0000		0.0000	0.0000	0.0000	0.0000	0.0000
Vendor	0.0679	1.4141	0.4175	0.0112	17.0283	0.0192	17.0474	1.7799	0.0183	1.7982		1,174.9924	1,174.9924	3.0900e-003	0.1603	1,222.8337
Worker	1.9935	1.3011	21.3084	0.0488	254.2536	0.0239	254.2775	26.2408	0.0220	26.2628		4,928.1623	4,928.1623	0.0945	0.1126	4,964.0898
Total	2.0614	2.7152	21.7258	0.0599	271.2819	0.0431	271.3250	28.0207	0.0404	28.0610		6,103.1547	6,103.1547	0.0976	0.2729	6,186.9235

Northstar #1 Project - UNMITIGATED - Imperial County, Summer

EMFAC Off-Model Adjustment Factors for Gasoline Light Duty Vehicle to Account for the SAFE Vehicle Rule Not Applied

3.4 Building Construction - 2023

Mitigated Construction On-Site

	ROG	NOx	CO	SO2	Fugitive PM10	Exhaust PM10	PM10 Total	Fugitive PM2.5	Exhaust PM2.5	PM2.5 Total	Bio- CO2	NBio- CO2	Total CO2	CH4	N2O	CO2e
Category	lb/day										lb/day					
Off-Road	5.2299	45.8103	51.1124	0.1121		2.0654	2.0654		1.9077	1.9077	0.0000	10,764.81 65	10,764.81 65	3.4068		10,849.98 66
Total	5.2299	45.8103	51.1124	0.1121		2.0654	2.0654		1.9077	1.9077	0.0000	10,764.81 65	10,764.81 65	3.4068		10,849.98 66

Mitigated Construction Off-Site

	ROG	NOx	CO	SO2	Fugitive PM10	Exhaust PM10	PM10 Total	Fugitive PM2.5	Exhaust PM2.5	PM2.5 Total	Bio- CO2	NBio- CO2	Total CO2	CH4	N2O	CO2e
Category	lb/day										lb/day					
Hauling	0.0000	0.0000	0.0000	0.0000	0.0000	0.0000	0.0000	0.0000	0.0000	0.0000		0.0000	0.0000	0.0000	0.0000	0.0000
Vendor	0.0679	1.4141	0.4175	0.0112	17.0283	0.0192	17.0474	1.7799	0.0183	1.7982		1,174.992 4	1,174.992 4	3.0900e- 003	0.1603	1,222.833 7
Worker	1.9935	1.3011	21.3084	0.0488	254.2536	0.0239	254.2775	26.2408	0.0220	26.2628		4,928.162 3	4,928.162 3	0.0945	0.1126	4,964.089 8
Total	2.0614	2.7152	21.7258	0.0599	271.2819	0.0431	271.3250	28.0207	0.0404	28.0610		6,103.154 7	6,103.154 7	0.0976	0.2729	6,186.923 5

Northstar #1 Project - UNMITIGATED - Imperial County, Summer

EMFAC Off-Model Adjustment Factors for Gasoline Light Duty Vehicle to Account for the SAFE Vehicle Rule Not Applied

3.4 Building Construction - 2024

Unmitigated Construction On-Site

	ROG	NOx	CO	SO2	Fugitive PM10	Exhaust PM10	PM10 Total	Fugitive PM2.5	Exhaust PM2.5	PM2.5 Total	Bio- CO2	NBio- CO2	Total CO2	CH4	N2O	CO2e
Category	lb/day										lb/day					
Off-Road	5.0777	43.3618	50.9456	0.1122		1.9154	1.9154		1.7691	1.7691		10,766.99 65	10,766.99 65	3.4061		10,852.14 77
Total	5.0777	43.3618	50.9456	0.1122		1.9154	1.9154		1.7691	1.7691		10,766.99 65	10,766.99 65	3.4061		10,852.14 77

Unmitigated Construction Off-Site

	ROG	NOx	CO	SO2	Fugitive PM10	Exhaust PM10	PM10 Total	Fugitive PM2.5	Exhaust PM2.5	PM2.5 Total	Bio- CO2	NBio- CO2	Total CO2	CH4	N2O	CO2e
Category	lb/day										lb/day					
Hauling	0.0000	0.0000	0.0000	0.0000	0.0000	0.0000	0.0000	0.0000	0.0000	0.0000		0.0000	0.0000	0.0000	0.0000	0.0000
Vendor	0.0642	1.4085	0.3859	0.0110	17.0283	0.0191	17.0474	1.7799	0.0183	1.7982		1,159.037 0	1,159.037 0	2.9300e- 003	0.1572	1,205.964 9
Worker	1.8584	1.1452	19.5473	0.0473	254.2536	0.0227	254.2763	26.2408	0.0209	26.2617		4,779.992 3	4,779.992 3	0.0842	0.1032	4,812.858 9
Total	1.9226	2.5537	19.9332	0.0583	271.2819	0.0418	271.3237	28.0207	0.0392	28.0598		5,939.029 3	5,939.029 3	0.0872	0.2605	6,018.823 8

Northstar #1 Project - UNMITIGATED - Imperial County, Summer

EMFAC Off-Model Adjustment Factors for Gasoline Light Duty Vehicle to Account for the SAFE Vehicle Rule Not Applied

3.4 Building Construction - 2024

Mitigated Construction On-Site

	ROG	NOx	CO	SO2	Fugitive PM10	Exhaust PM10	PM10 Total	Fugitive PM2.5	Exhaust PM2.5	PM2.5 Total	Bio- CO2	NBio- CO2	Total CO2	CH4	N2O	CO2e
Category	lb/day										lb/day					
Off-Road	5.0777	43.3618	50.9456	0.1122		1.9154	1.9154		1.7691	1.7691	0.0000	10,766.99 64	10,766.99 64	3.4061		10,852.14 77
Total	5.0777	43.3618	50.9456	0.1122		1.9154	1.9154		1.7691	1.7691	0.0000	10,766.99 64	10,766.99 64	3.4061		10,852.14 77

Mitigated Construction Off-Site

	ROG	NOx	CO	SO2	Fugitive PM10	Exhaust PM10	PM10 Total	Fugitive PM2.5	Exhaust PM2.5	PM2.5 Total	Bio- CO2	NBio- CO2	Total CO2	CH4	N2O	CO2e
Category	lb/day										lb/day					
Hauling	0.0000	0.0000	0.0000	0.0000	0.0000	0.0000	0.0000	0.0000	0.0000	0.0000		0.0000	0.0000	0.0000	0.0000	0.0000
Vendor	0.0642	1.4085	0.3859	0.0110	17.0283	0.0191	17.0474	1.7799	0.0183	1.7982		1,159.037 0	1,159.037 0	2.9300e- 003	0.1572	1,205.964 9
Worker	1.8584	1.1452	19.5473	0.0473	254.2536	0.0227	254.2763	26.2408	0.0209	26.2617		4,779.992 3	4,779.992 3	0.0842	0.1032	4,812.858 9
Total	1.9226	2.5537	19.9332	0.0583	271.2819	0.0418	271.3237	28.0207	0.0392	28.0598		5,939.029 3	5,939.029 3	0.0872	0.2605	6,018.823 8

Northstar #1 Project - UNMITIGATED - Imperial County, Summer

EMFAC Off-Model Adjustment Factors for Gasoline Light Duty Vehicle to Account for the SAFE Vehicle Rule Not Applied

4.0 Operational Detail - Mobile

4.1 Mitigation Measures Mobile

	ROG	NOx	CO	SO2	Fugitive PM10	Exhaust PM10	PM10 Total	Fugitive PM2.5	Exhaust PM2.5	PM2.5 Total	Bio- CO2	NBio- CO2	Total CO2	CH4	N2O	CO2e
Category	lb/day										lb/day					
Mitigated	0.0138	0.7763	0.1503	4.8000e-003	3.5357	0.0114	3.5470	0.3805	0.0109	0.3914		508.9185	508.9185	1.1100e-003	0.0800	532.7858
Unmitigated	0.0138	0.7763	0.1503	4.8000e-003	3.5357	0.0114	3.5470	0.3805	0.0109	0.3914		508.9185	508.9185	1.1100e-003	0.0800	532.7858

4.2 Trip Summary Information

Land Use	Average Daily Trip Rate			Unmitigated	Mitigated
	Weekday	Saturday	Sunday	Annual VMT	Annual VMT
Other Non-Asphalt Surfaces	4.02	0.00	0.00	49,100	49,100
Total	4.02	0.00	0.00	49,100	49,100

4.3 Trip Type Information

Land Use	Miles			Trip %			Trip Purpose %		
	H-W or C-W	H-S or C-C	H-O or C-NW	H-W or C-W	H-S or C-C	H-O or C-NW	Primary	Diverted	Pass-by
Other Non-Asphalt Surfaces	47.00	47.00	47.00	0.00	100.00	0.00	100	0	0

4.4 Fleet Mix

Land Use	LDA	LDT1	LDT2	MDV	LHD1	LHD2	MHD	HHD	OBUS	UBUS	MCY	SBUS	MH
Other Non-Asphalt Surfaces	0.000000	0.000000	0.000000	0.000000	0.000000	0.000000	0.000000	1.000000	0.000000	0.000000	0.000000	0.000000	0.000000

Northstar #1 Project - UNMITIGATED - Imperial County, Summer

EMFAC Off-Model Adjustment Factors for Gasoline Light Duty Vehicle to Account for the SAFE Vehicle Rule Not Applied

5.0 Energy Detail

Historical Energy Use: N

5.1 Mitigation Measures Energy

	ROG	NOx	CO	SO2	Fugitive PM10	Exhaust PM10	PM10 Total	Fugitive PM2.5	Exhaust PM2.5	PM2.5 Total	Bio- CO2	NBio- CO2	Total CO2	CH4	N2O	CO2e
Category	lb/day										lb/day					
NaturalGas Mitigated	0.0000	0.0000	0.0000	0.0000		0.0000	0.0000		0.0000	0.0000		0.0000	0.0000	0.0000	0.0000	0.0000
NaturalGas Unmitigated	0.0000	0.0000	0.0000	0.0000		0.0000	0.0000		0.0000	0.0000		0.0000	0.0000	0.0000	0.0000	0.0000

5.2 Energy by Land Use - NaturalGas

Unmitigated

	NaturalGas Use	ROG	NOx	CO	SO2	Fugitive PM10	Exhaust PM10	PM10 Total	Fugitive PM2.5	Exhaust PM2.5	PM2.5 Total	Bio- CO2	NBio- CO2	Total CO2	CH4	N2O	CO2e
Land Use	kBTU/yr	lb/day										lb/day					
Other Non-Asphalt Surfaces	0	0.0000	0.0000	0.0000	0.0000		0.0000	0.0000		0.0000	0.0000		0.0000	0.0000	0.0000	0.0000	0.0000
Total		0.0000	0.0000	0.0000	0.0000		0.0000	0.0000		0.0000	0.0000		0.0000	0.0000	0.0000	0.0000	0.0000

Northstar #1 Project - UNMITIGATED - Imperial County, Summer

EMFAC Off-Model Adjustment Factors for Gasoline Light Duty Vehicle to Account for the SAFE Vehicle Rule Not Applied

5.2 Energy by Land Use - NaturalGas

Mitigated

	NaturalGas Use	ROG	NOx	CO	SO2	Fugitive PM10	Exhaust PM10	PM10 Total	Fugitive PM2.5	Exhaust PM2.5	PM2.5 Total	Bio- CO2	NBio- CO2	Total CO2	CH4	N2O	CO2e
Land Use	kBTU/yr	lb/day										lb/day					
Other Non-Asphalt Surfaces	0	0.0000	0.0000	0.0000	0.0000		0.0000	0.0000		0.0000	0.0000		0.0000	0.0000	0.0000	0.0000	0.0000
Total		0.0000	0.0000	0.0000	0.0000		0.0000	0.0000		0.0000	0.0000		0.0000	0.0000	0.0000	0.0000	0.0000

6.0 Area Detail

6.1 Mitigation Measures Area

	ROG	NOx	CO	SO2	Fugitive PM10	Exhaust PM10	PM10 Total	Fugitive PM2.5	Exhaust PM2.5	PM2.5 Total	Bio- CO2	NBio- CO2	Total CO2	CH4	N2O	CO2e
Category	lb/day										lb/day					
Mitigated	5.8596	2.7000e-004	0.0293	0.0000		1.0000e-004	1.0000e-004		1.0000e-004	1.0000e-004		0.0628	0.0628	1.6000e-004		0.0669
Unmitigated	5.8596	2.7000e-004	0.0293	0.0000		1.0000e-004	1.0000e-004		1.0000e-004	1.0000e-004		0.0628	0.0628	1.6000e-004		0.0669

Northstar #1 Project - UNMITIGATED - Imperial County, Summer

EMFAC Off-Model Adjustment Factors for Gasoline Light Duty Vehicle to Account for the SAFE Vehicle Rule Not Applied

6.2 Area by SubCategory

Unmitigated

	ROG	NOx	CO	SO2	Fugitive PM10	Exhaust PM10	PM10 Total	Fugitive PM2.5	Exhaust PM2.5	PM2.5 Total	Bio- CO2	NBio- CO2	Total CO2	CH4	N2O	CO2e
SubCategory	lb/day										lb/day					
Architectural Coating	1.4288					0.0000	0.0000		0.0000	0.0000			0.0000			0.0000
Consumer Products	4.4281					0.0000	0.0000		0.0000	0.0000			0.0000			0.0000
Landscaping	2.7000e-003	2.7000e-004	0.0293	0.0000		1.0000e-004	1.0000e-004		1.0000e-004	1.0000e-004		0.0628	0.0628	1.6000e-004		0.0669
Total	5.8596	2.7000e-004	0.0293	0.0000		1.0000e-004	1.0000e-004		1.0000e-004	1.0000e-004		0.0628	0.0628	1.6000e-004		0.0669

Northstar #1 Project - UNMITIGATED - Imperial County, Summer

EMFAC Off-Model Adjustment Factors for Gasoline Light Duty Vehicle to Account for the SAFE Vehicle Rule Not Applied

6.2 Area by SubCategory

Mitigated

	ROG	NOx	CO	SO2	Fugitive PM10	Exhaust PM10	PM10 Total	Fugitive PM2.5	Exhaust PM2.5	PM2.5 Total	Bio- CO2	NBio- CO2	Total CO2	CH4	N2O	CO2e
SubCategory	lb/day										lb/day					
Architectural Coating	1.4288					0.0000	0.0000		0.0000	0.0000			0.0000			0.0000
Consumer Products	4.4281					0.0000	0.0000		0.0000	0.0000			0.0000			0.0000
Landscaping	2.7000e-003	2.7000e-004	0.0293	0.0000		1.0000e-004	1.0000e-004		1.0000e-004	1.0000e-004		0.0628	0.0628	1.6000e-004		0.0669
Total	5.8596	2.7000e-004	0.0293	0.0000		1.0000e-004	1.0000e-004		1.0000e-004	1.0000e-004		0.0628	0.0628	1.6000e-004		0.0669

7.0 Water Detail

7.1 Mitigation Measures Water

Northstar #1 Project - UNMITIGATED - Imperial County, Summer

EMFAC Off-Model Adjustment Factors for Gasoline Light Duty Vehicle to Account for the SAFE Vehicle Rule Not Applied

8.0 Waste Detail

8.1 Mitigation Measures Waste

9.0 Operational Offroad

Equipment Type	Number	Hours/Day	Days/Year	Horse Power	Load Factor	Fuel Type
----------------	--------	-----------	-----------	-------------	-------------	-----------

10.0 Stationary Equipment

Fire Pumps and Emergency Generators

Equipment Type	Number	Hours/Day	Hours/Year	Horse Power	Load Factor	Fuel Type
----------------	--------	-----------	------------	-------------	-------------	-----------

Boilers

Equipment Type	Number	Heat Input/Day	Heat Input/Year	Boiler Rating	Fuel Type
----------------	--------	----------------	-----------------	---------------	-----------

User Defined Equipment

Equipment Type	Number
----------------	--------

11.0 Vegetation

Northstar #1 Project - MITIGATED - Imperial County, Summer

EMFAC Off-Model Adjustment Factors for Gasoline Light Duty Vehicle to Account for the SAFE Vehicle Rule Not Applied

Northstar #1 Project - MITIGATED

Imperial County, Summer

1.0 Project Characteristics

1.1 Land Usage

Land Uses	Size	Metric	Lot Acreage	Floor Surface Area	Population
Other Non-Asphalt Surfaces	287.00	Acre	287.00	12,501,720.00	0

1.2 Other Project Characteristics

Urbanization	Rural	Wind Speed (m/s)	3.4	Precipitation Freq (Days)	12
Climate Zone	15	Operational Year		2024	
Utility Company	Imperial Irrigation District				
CO2 Intensity (lb/MWhr)	189.98	CH4 Intensity (lb/MWhr)	0.033	N2O Intensity (lb/MWhr)	0.004

1.3 User Entered Comments & Non-Default Data

Project Characteristics -

Land Use -

Construction Phase - Days of construction based on previous Z Global solar generation facility projects in Imperial County

Off-road Equipment - Equipment derived from previous Z Global solar generation facilities in Imperial County

Off-road Equipment - Ibid

Off-road Equipment - Ibid

Grading -

Construction Off-road Equipment Mitigation - ICAPCD Regulation VIII applied.

Vehicle Trips - Assume 4 heavy duty trucks trips daily

Trips and VMT - Maximum 75 workers assumed. Commute miles derived from an averaged distance between the Project Site and Brawley and the Project Site and Palm Springs [47 miles]

On-road Fugitive Dust - Mitigation Measure AQ-1

Northstar #1 Project - MITIGATED - Imperial County, Summer

EMFAC Off-Model Adjustment Factors for Gasoline Light Duty Vehicle to Account for the SAFE Vehicle Rule Not Applied

Road Dust - 1.15 miles of site access unpaved. Equates to 2.4 percent of the route

Fleet Mix - Assume 100% heavy duty truck fleet mix

Table Name	Column Name	Default Value	New Value
tblConstructionPhase	NumDays	4,650.00	85.00
tblConstructionPhase	NumDays	465.00	120.00
tblConstructionPhase	NumDays	180.00	60.00
tblConstructionPhase	PhaseEndDate	10/22/2043	3/5/2024
tblConstructionPhase	PhaseEndDate	12/25/2025	11/7/2023
tblConstructionPhase	PhaseEndDate	3/14/2024	5/23/2023
tblConstructionPhase	PhaseStartDate	12/26/2025	11/8/2023
tblConstructionPhase	PhaseStartDate	3/15/2024	5/24/2023
tblConstructionPhase	PhaseStartDate	7/7/2023	3/1/2023
tblFleetMix	HHD	0.02	1.00
tblFleetMix	LDA	0.53	0.00
tblFleetMix	LDT1	0.06	0.00
tblFleetMix	LDT2	0.18	0.00
tblFleetMix	LHD1	0.03	0.00
tblFleetMix	LHD2	6.8510e-003	0.00
tblFleetMix	MCY	0.02	0.00
tblFleetMix	MDV	0.15	0.00
tblFleetMix	MH	3.5040e-003	0.00
tblFleetMix	MHD	8.3160e-003	0.00
tblFleetMix	OBUS	9.2500e-004	0.00
tblFleetMix	SBUS	7.6600e-004	0.00
tblFleetMix	UBUS	1.2000e-004	0.00
tblOffRoadEquipment	LoadFactor	0.38	0.38
tblOffRoadEquipment	LoadFactor	0.38	0.38
tblOffRoadEquipment	LoadFactor	0.38	0.38
tblOffRoadEquipment	LoadFactor	0.42	0.42

Northstar #1 Project - MITIGATED - Imperial County, Summer

EMFAC Off-Model Adjustment Factors for Gasoline Light Duty Vehicle to Account for the SAFE Vehicle Rule Not Applied

tblOffRoadEquipment	LoadFactor	0.36	0.36
tblOffRoadEquipment	LoadFactor	0.38	0.38
tblOffRoadEquipment	LoadFactor	0.40	0.40
tblOffRoadEquipment	LoadFactor	0.50	0.50
tblOffRoadEquipment	OffRoadEquipmentType		Off-Highway Trucks
tblOffRoadEquipment	OffRoadEquipmentType		Off-Highway Trucks
tblOffRoadEquipment	OffRoadEquipmentType		Off-Highway Trucks
tblOffRoadEquipment	OffRoadEquipmentType		Pavers
tblOffRoadEquipment	OffRoadEquipmentType		Paving Equipment
tblOffRoadEquipment	OffRoadEquipmentType		Plate Compactors
tblOffRoadEquipment	OffRoadEquipmentType		Rollers
tblOffRoadEquipment	OffRoadEquipmentType		Rough Terrain Forklifts
tblOffRoadEquipment	OffRoadEquipmentType		Trenchers
tblOffRoadEquipment	OffRoadEquipmentUnitAmount	2.00	4.00
tblOffRoadEquipment	OffRoadEquipmentUnitAmount	3.00	0.00
tblOffRoadEquipment	OffRoadEquipmentUnitAmount	1.00	0.00
tblOffRoadEquipment	OffRoadEquipmentUnitAmount	1.00	3.00
tblOffRoadEquipment	OffRoadEquipmentUnitAmount	1.00	2.00
tblOffRoadEquipment	OffRoadEquipmentUnitAmount	3.00	2.00
tblOffRoadEquipment	OffRoadEquipmentUnitAmount	3.00	4.00
tblOffRoadEquipment	OffRoadEquipmentUnitAmount	2.00	4.00
tblOffRoadEquipment	OffRoadEquipmentUnitAmount	4.00	2.00
tblOnRoadDust	VendorPercentPave	50.00	100.00
tblOnRoadDust	WorkerPercentPave	50.00	100.00
tblOnRoadDust	WorkerPercentPave	50.00	100.00
tblOnRoadDust	WorkerPercentPave	50.00	100.00
tblProjectCharacteristics	UrbanizationLevel	Urban	Rural
tblRoadDust	RoadPercentPave	50	97.6
tblTripsAndVMT	VendorTripLength	11.90	47.00

Northstar #1 Project - MITIGATED - Imperial County, Summer

EMFAC Off-Model Adjustment Factors for Gasoline Light Duty Vehicle to Account for the SAFE Vehicle Rule Not Applied

tblTripsAndVMT	VendorTripNumber	2,049.00	10.00
tblTripsAndVMT	WorkerTripLength	10.20	47.00
tblTripsAndVMT	WorkerTripLength	10.20	47.00
tblTripsAndVMT	WorkerTripLength	10.20	47.00
tblTripsAndVMT	WorkerTripNumber	5,251.00	150.00
tblVehicleTrips	CC_TL	9.50	47.00
tblVehicleTrips	CC_TTP	0.00	100.00
tblVehicleTrips	CNW_TL	11.90	47.00
tblVehicleTrips	CW_TL	16.40	47.00
tblVehicleTrips	PR_TP	0.00	100.00
tblVehicleTrips	WD_TR	0.00	0.01

2.0 Emissions Summary

Northstar #1 Project - MITIGATED - Imperial County, Summer

EMFAC Off-Model Adjustment Factors for Gasoline Light Duty Vehicle to Account for the SAFE Vehicle Rule Not Applied

2.1 Overall Construction (Maximum Daily Emission)

Unmitigated Construction

	ROG	NOx	CO	SO2	Fugitive PM10	Exhaust PM10	PM10 Total	Fugitive PM2.5	Exhaust PM2.5	PM2.5 Total	Bio- CO2	NBio- CO2	Total CO2	CH4	N2O	CO2e
Year	lb/day										lb/day					
2023	7.2912	61.0501	72.8382	0.1721	18.2451	2.4862	20.7313	7.5145	2.2873	9.8018	0.0000	16,867.97 12	16,867.97 12	3.5860	0.2729	17,036.91 01
2024	7.0003	45.9154	70.8788	0.1705	5.7927	1.9571	7.7498	1.5456	1.8082	3.3538	0.0000	16,706.02 58	16,706.02 58	3.4932	0.2605	16,870.97 15
Maximum	7.2912	61.0501	72.8382	0.1721	18.2451	2.4862	20.7313	7.5145	2.2873	9.8018	0.0000	16,867.97 12	16,867.97 12	3.5860	0.2729	17,036.91 01

Mitigated Construction

	ROG	NOx	CO	SO2	Fugitive PM10	Exhaust PM10	PM10 Total	Fugitive PM2.5	Exhaust PM2.5	PM2.5 Total	Bio- CO2	NBio- CO2	Total CO2	CH4	N2O	CO2e
Year	lb/day										lb/day					
2023	7.2912	61.0501	72.8382	0.1721	8.9960	2.4862	11.4822	3.5899	2.2873	5.8772	0.0000	16,867.97 12	16,867.97 12	3.5860	0.2729	17,036.91 01
2024	7.0003	45.9154	70.8788	0.1705	5.7927	1.9571	7.7498	1.5456	1.8082	3.3538	0.0000	16,706.02 57	16,706.02 57	3.4932	0.2605	16,870.97 15
Maximum	7.2912	61.0501	72.8382	0.1721	8.9960	2.4862	11.4822	3.5899	2.2873	5.8772	0.0000	16,867.97 12	16,867.97 12	3.5860	0.2729	17,036.91 01

Northstar #1 Project - MITIGATED - Imperial County, Summer

EMFAC Off-Model Adjustment Factors for Gasoline Light Duty Vehicle to Account for the SAFE Vehicle Rule Not Applied

2.2 Overall Operational

Unmitigated Operational

	ROG	NOx	CO	SO2	Fugitive PM10	Exhaust PM10	PM10 Total	Fugitive PM2.5	Exhaust PM2.5	PM2.5 Total	Bio- CO2	NBio- CO2	Total CO2	CH4	N2O	CO2e
Category	lb/day										lb/day					
Area	5.8596	2.7000e-004	0.0293	0.0000		1.0000e-004	1.0000e-004		1.0000e-004	1.0000e-004		0.0628	0.0628	1.6000e-004		0.0669
Energy	0.0000	0.0000	0.0000	0.0000		0.0000	0.0000		0.0000	0.0000		0.0000	0.0000	0.0000	0.0000	0.0000
Mobile	0.0138	0.7763	0.1503	4.8000e-003	3.5357	0.0114	3.5470	0.3805	0.0109	0.3914		508.9185	508.9185	1.1100e-003	0.0800	532.7858
Total	5.8734	0.7766	0.1795	4.8000e-003	3.5357	0.0115	3.5471	0.3805	0.0110	0.3915		508.9814	508.9814	1.2700e-003	0.0800	532.8527

Mitigated Operational

	ROG	NOx	CO	SO2	Fugitive PM10	Exhaust PM10	PM10 Total	Fugitive PM2.5	Exhaust PM2.5	PM2.5 Total	Bio- CO2	NBio- CO2	Total CO2	CH4	N2O	CO2e
Category	lb/day										lb/day					
Area	5.8596	2.7000e-004	0.0293	0.0000		1.0000e-004	1.0000e-004		1.0000e-004	1.0000e-004		0.0628	0.0628	1.6000e-004		0.0669
Energy	0.0000	0.0000	0.0000	0.0000		0.0000	0.0000		0.0000	0.0000		0.0000	0.0000	0.0000	0.0000	0.0000
Mobile	0.0138	0.7763	0.1503	4.8000e-003	3.5357	0.0114	3.5470	0.3805	0.0109	0.3914		508.9185	508.9185	1.1100e-003	0.0800	532.7858
Total	5.8734	0.7766	0.1795	4.8000e-003	3.5357	0.0115	3.5471	0.3805	0.0110	0.3915		508.9814	508.9814	1.2700e-003	0.0800	532.8527

Northstar #1 Project - MITIGATED - Imperial County, Summer

EMFAC Off-Model Adjustment Factors for Gasoline Light Duty Vehicle to Account for the SAFE Vehicle Rule Not Applied

	ROG	NOx	CO	SO2	Fugitive PM10	Exhaust PM10	PM10 Total	Fugitive PM2.5	Exhaust PM2.5	PM2.5 Total	Bio- CO2	NBio-CO2	Total CO2	CH4	N2O	CO2e
Percent Reduction	0.00	0.00	0.00	0.00	0.00	0.00	0.00	0.00	0.00	0.00	0.00	0.00	0.00	0.00	0.00	0.00

3.0 Construction Detail

Construction Phase

Phase Number	Phase Name	Phase Type	Start Date	End Date	Num Days Week	Num Days	Phase Description
1	Site Preparation	Site Preparation	3/1/2023	5/23/2023	5	60	
2	Grading	Grading	5/24/2023	11/7/2023	5	120	
3	Building Construction	Building Construction	11/8/2023	3/5/2024	5	85	

Acres of Grading (Site Preparation Phase): 60

Acres of Grading (Grading Phase): 540

Acres of Paving: 287

Residential Indoor: 0; Residential Outdoor: 0; Non-Residential Indoor: 0; Non-Residential Outdoor: 0; Striped Parking Area: 0 (Architectural Coating – sqft)

OffRoad Equipment

Phase Name	Offroad Equipment Type	Amount	Usage Hours	Horse Power	Load Factor
Site Preparation	Off-Highway Trucks	1	8.00	402	0.38
Grading	Off-Highway Trucks	1	8.00	402	0.38
Building Construction	Cranes	1	7.00	231	0.29
Building Construction	Off-Highway Trucks	4	8.00	402	0.38
Grading	Excavators	4	8.00	158	0.38
Building Construction	Forklifts	0	8.00	89	0.20
Building Construction	Generator Sets	0	8.00	84	0.74
Grading	Graders	3	8.00	187	0.41

Northstar #1 Project - MITIGATED - Imperial County, Summer

EMFAC Off-Model Adjustment Factors for Gasoline Light Duty Vehicle to Account for the SAFE Vehicle Rule Not Applied

Building Construction	Pavers	1	8.00	130	0.42
Building Construction	Paving Equipment	2	8.00	132	0.36
Building Construction	Plate Compactors	4	8.00	8	0.43
Building Construction	Rollers	2	8.00	80	0.38
Grading	Rubber Tired Dozers	2	8.00	247	0.40
Site Preparation	Rubber Tired Dozers	2	8.00	247	0.40
Grading	Scrapers	2	8.00	367	0.48
Building Construction	Tractors/Loaders/Backhoes	4	7.00	97	0.37
Grading	Tractors/Loaders/Backhoes	4	8.00	97	0.37
Site Preparation	Tractors/Loaders/Backhoes	2	8.00	97	0.37
Building Construction	Welders	1	8.00	46	0.45
Building Construction	Rough Terrain Forklifts	4	8.00	100	0.40
Building Construction	Trenchers	2	8.00	78	0.50

Trips and VMT

Phase Name	Offroad Equipment Count	Worker Trip Number	Vendor Trip Number	Hauling Trip Number	Worker Trip Length	Vendor Trip Length	Hauling Trip Length	Worker Vehicle Class	Vendor Vehicle Class	Hauling Vehicle Class
Site Preparation	5	13.00	0.00	0.00	47.00	11.90	20.00	LD_Mix	HDT_Mix	HHDT
Grading	16	40.00	0.00	0.00	47.00	11.90	20.00	LD_Mix	HDT_Mix	HHDT
Building Construction	25	150.00	10.00	0.00	47.00	47.00	20.00	LD_Mix	HDT_Mix	HHDT

3.1 Mitigation Measures Construction

Water Exposed Area

Reduce Vehicle Speed on Unpaved Roads

Northstar #1 Project - MITIGATED - Imperial County, Summer

EMFAC Off-Model Adjustment Factors for Gasoline Light Duty Vehicle to Account for the SAFE Vehicle Rule Not Applied

3.2 Site Preparation - 2023

Unmitigated Construction On-Site

	ROG	NOx	CO	SO2	Fugitive PM10	Exhaust PM10	PM10 Total	Fugitive PM2.5	Exhaust PM2.5	PM2.5 Total	Bio- CO2	NBio- CO2	Total CO2	CH4	N2O	CO2e
Category	lb/day										lb/day					
Fugitive Dust					13.1047	0.0000	13.1047	6.7350	0.0000	6.7350			0.0000			0.0000
Off-Road	2.1784	20.9114	13.9803	0.0366		0.9231	0.9231		0.8493	0.8493		3,543.4424	3,543.4424	1.1460		3,572.0929
Total	2.1784	20.9114	13.9803	0.0366	13.1047	0.9231	14.0278	6.7350	0.8493	7.5842		3,543.4424	3,543.4424	1.1460		3,572.0929

Unmitigated Construction Off-Site

	ROG	NOx	CO	SO2	Fugitive PM10	Exhaust PM10	PM10 Total	Fugitive PM2.5	Exhaust PM2.5	PM2.5 Total	Bio- CO2	NBio- CO2	Total CO2	CH4	N2O	CO2e
Category	lb/day										lb/day					
Hauling	0.0000	0.0000	0.0000	0.0000	0.0000	0.0000	0.0000	0.0000	0.0000	0.0000		0.0000	0.0000	0.0000	0.0000	0.0000
Vendor	0.0000	0.0000	0.0000	0.0000	0.0000	0.0000	0.0000	0.0000	0.0000	0.0000		0.0000	0.0000	0.0000	0.0000	0.0000
Worker	0.1728	0.1128	1.8467	4.2300e-003	0.4643	2.0700e-003	0.4664	0.1231	1.9100e-003	0.1250		427.1074	427.1074	8.1900e-003	9.7600e-003	430.2211
Total	0.1728	0.1128	1.8467	4.2300e-003	0.4643	2.0700e-003	0.4664	0.1231	1.9100e-003	0.1250		427.1074	427.1074	8.1900e-003	9.7600e-003	430.2211

Northstar #1 Project - MITIGATED - Imperial County, Summer

EMFAC Off-Model Adjustment Factors for Gasoline Light Duty Vehicle to Account for the SAFE Vehicle Rule Not Applied

3.2 Site Preparation - 2023

Mitigated Construction On-Site

	ROG	NOx	CO	SO2	Fugitive PM10	Exhaust PM10	PM10 Total	Fugitive PM2.5	Exhaust PM2.5	PM2.5 Total	Bio- CO2	NBio- CO2	Total CO2	CH4	N2O	CO2e
Category	lb/day										lb/day					
Fugitive Dust					5.8971	0.0000	5.8971	3.0307	0.0000	3.0307			0.0000			0.0000
Off-Road	2.1784	20.9114	13.9803	0.0366		0.9231	0.9231		0.8493	0.8493	0.0000	3,543.442 3	3,543.442 3	1.1460		3,572.092 9
Total	2.1784	20.9114	13.9803	0.0366	5.8971	0.9231	6.8202	3.0307	0.8493	3.8800	0.0000	3,543.442 3	3,543.442 3	1.1460		3,572.092 9

Mitigated Construction Off-Site

	ROG	NOx	CO	SO2	Fugitive PM10	Exhaust PM10	PM10 Total	Fugitive PM2.5	Exhaust PM2.5	PM2.5 Total	Bio- CO2	NBio- CO2	Total CO2	CH4	N2O	CO2e
Category	lb/day										lb/day					
Hauling	0.0000	0.0000	0.0000	0.0000	0.0000	0.0000	0.0000	0.0000	0.0000	0.0000		0.0000	0.0000	0.0000	0.0000	0.0000
Vendor	0.0000	0.0000	0.0000	0.0000	0.0000	0.0000	0.0000	0.0000	0.0000	0.0000		0.0000	0.0000	0.0000	0.0000	0.0000
Worker	0.1728	0.1128	1.8467	4.2300e-003	0.4643	2.0700e-003	0.4664	0.1231	1.9100e-003	0.1250		427.1074	427.1074	8.1900e-003	9.7600e-003	430.2211
Total	0.1728	0.1128	1.8467	4.2300e-003	0.4643	2.0700e-003	0.4664	0.1231	1.9100e-003	0.1250		427.1074	427.1074	8.1900e-003	9.7600e-003	430.2211

Northstar #1 Project - MITIGATED - Imperial County, Summer

EMFAC Off-Model Adjustment Factors for Gasoline Light Duty Vehicle to Account for the SAFE Vehicle Rule Not Applied

3.3 Grading - 2023

Unmitigated Construction On-Site

	ROG	NOx	CO	SO2	Fugitive PM10	Exhaust PM10	PM10 Total	Fugitive PM2.5	Exhaust PM2.5	PM2.5 Total	Bio- CO2	NBio- CO2	Total CO2	CH4	N2O	CO2e
Category	lb/day										lb/day					
Fugitive Dust					16.8164	0.0000	16.8164	7.1358	0.0000	7.1358			0.0000			0.0000
Off-Road	5.9598	60.7032	48.8259	0.1137		2.4798	2.4798		2.2814	2.2814		11,009.84 10	11,009.84 10	3.5608		11,098.86 11
Total	5.9598	60.7032	48.8259	0.1137	16.8164	2.4798	19.2962	7.1358	2.2814	9.4172		11,009.84 10	11,009.84 10	3.5608		11,098.86 11

Unmitigated Construction Off-Site

	ROG	NOx	CO	SO2	Fugitive PM10	Exhaust PM10	PM10 Total	Fugitive PM2.5	Exhaust PM2.5	PM2.5 Total	Bio- CO2	NBio- CO2	Total CO2	CH4	N2O	CO2e
Category	lb/day										lb/day					
Hauling	0.0000	0.0000	0.0000	0.0000	0.0000	0.0000	0.0000	0.0000	0.0000	0.0000		0.0000	0.0000	0.0000	0.0000	0.0000
Vendor	0.0000	0.0000	0.0000	0.0000	0.0000	0.0000	0.0000	0.0000	0.0000	0.0000		0.0000	0.0000	0.0000	0.0000	0.0000
Worker	0.5316	0.3470	5.6822	0.0130	1.4287	6.3800e-003	1.4350	0.3788	5.8700e-003	0.3847		1,314.176 6	1,314.176 6	0.0252	0.0300	1,323.757 3
Total	0.5316	0.3470	5.6822	0.0130	1.4287	6.3800e-003	1.4350	0.3788	5.8700e-003	0.3847		1,314.176 6	1,314.176 6	0.0252	0.0300	1,323.757 3

Northstar #1 Project - MITIGATED - Imperial County, Summer

EMFAC Off-Model Adjustment Factors for Gasoline Light Duty Vehicle to Account for the SAFE Vehicle Rule Not Applied

3.3 Grading - 2023

Mitigated Construction On-Site

	ROG	NOx	CO	SO2	Fugitive PM10	Exhaust PM10	PM10 Total	Fugitive PM2.5	Exhaust PM2.5	PM2.5 Total	Bio- CO2	NBio- CO2	Total CO2	CH4	N2O	CO2e
Category	lb/day										lb/day					
Fugitive Dust					7.5674	0.0000	7.5674	3.2111	0.0000	3.2111			0.0000			0.0000
Off-Road	5.9598	60.7032	48.8259	0.1137		2.4798	2.4798		2.2814	2.2814	0.0000	11,009.84 10	11,009.84 10	3.5608		11,098.86 11
Total	5.9598	60.7032	48.8259	0.1137	7.5674	2.4798	10.0472	3.2111	2.2814	5.4925	0.0000	11,009.84 10	11,009.84 10	3.5608		11,098.86 11

Mitigated Construction Off-Site

	ROG	NOx	CO	SO2	Fugitive PM10	Exhaust PM10	PM10 Total	Fugitive PM2.5	Exhaust PM2.5	PM2.5 Total	Bio- CO2	NBio- CO2	Total CO2	CH4	N2O	CO2e
Category	lb/day										lb/day					
Hauling	0.0000	0.0000	0.0000	0.0000	0.0000	0.0000	0.0000	0.0000	0.0000	0.0000		0.0000	0.0000	0.0000	0.0000	0.0000
Vendor	0.0000	0.0000	0.0000	0.0000	0.0000	0.0000	0.0000	0.0000	0.0000	0.0000		0.0000	0.0000	0.0000	0.0000	0.0000
Worker	0.5316	0.3470	5.6822	0.0130	1.4287	6.3800e-003	1.4350	0.3788	5.8700e-003	0.3847		1,314.176 6	1,314.176 6	0.0252	0.0300	1,323.757 3
Total	0.5316	0.3470	5.6822	0.0130	1.4287	6.3800e-003	1.4350	0.3788	5.8700e-003	0.3847		1,314.176 6	1,314.176 6	0.0252	0.0300	1,323.757 3

Northstar #1 Project - MITIGATED - Imperial County, Summer

EMFAC Off-Model Adjustment Factors for Gasoline Light Duty Vehicle to Account for the SAFE Vehicle Rule Not Applied

3.4 Building Construction - 2023

Unmitigated Construction On-Site

	ROG	NOx	CO	SO2	Fugitive PM10	Exhaust PM10	PM10 Total	Fugitive PM2.5	Exhaust PM2.5	PM2.5 Total	Bio- CO2	NBio- CO2	Total CO2	CH4	N2O	CO2e
Category	lb/day										lb/day					
Off-Road	5.2299	45.8103	51.1124	0.1121		2.0654	2.0654		1.9077	1.9077		10,764.8165	10,764.8165	3.4068		10,849.9866
Total	5.2299	45.8103	51.1124	0.1121		2.0654	2.0654		1.9077	1.9077		10,764.8165	10,764.8165	3.4068		10,849.9866

Unmitigated Construction Off-Site

	ROG	NOx	CO	SO2	Fugitive PM10	Exhaust PM10	PM10 Total	Fugitive PM2.5	Exhaust PM2.5	PM2.5 Total	Bio- CO2	NBio- CO2	Total CO2	CH4	N2O	CO2e
Category	lb/day										lb/day					
Hauling	0.0000	0.0000	0.0000	0.0000	0.0000	0.0000	0.0000	0.0000	0.0000	0.0000		0.0000	0.0000	0.0000	0.0000	0.0000
Vendor	0.0679	1.4141	0.4175	0.0112	0.4352	0.0192	0.4544	0.1252	0.0183	0.1435		1,174.9924	1,174.9924	3.0900e-003	0.1603	1,222.8337
Worker	1.9935	1.3011	21.3084	0.0488	5.3575	0.0239	5.3814	1.4204	0.0220	1.4424		4,928.1623	4,928.1623	0.0945	0.1126	4,964.0898
Total	2.0614	2.7152	21.7258	0.0599	5.7927	0.0431	5.8357	1.5456	0.0404	1.5859		6,103.1547	6,103.1547	0.0976	0.2729	6,186.9235

Northstar #1 Project - MITIGATED - Imperial County, Summer

EMFAC Off-Model Adjustment Factors for Gasoline Light Duty Vehicle to Account for the SAFE Vehicle Rule Not Applied

3.4 Building Construction - 2023

Mitigated Construction On-Site

	ROG	NOx	CO	SO2	Fugitive PM10	Exhaust PM10	PM10 Total	Fugitive PM2.5	Exhaust PM2.5	PM2.5 Total	Bio- CO2	NBio- CO2	Total CO2	CH4	N2O	CO2e
Category	lb/day										lb/day					
Off-Road	5.2299	45.8103	51.1124	0.1121		2.0654	2.0654		1.9077	1.9077	0.0000	10,764.81 65	10,764.81 65	3.4068		10,849.98 66
Total	5.2299	45.8103	51.1124	0.1121		2.0654	2.0654		1.9077	1.9077	0.0000	10,764.81 65	10,764.81 65	3.4068		10,849.98 66

Mitigated Construction Off-Site

	ROG	NOx	CO	SO2	Fugitive PM10	Exhaust PM10	PM10 Total	Fugitive PM2.5	Exhaust PM2.5	PM2.5 Total	Bio- CO2	NBio- CO2	Total CO2	CH4	N2O	CO2e
Category	lb/day										lb/day					
Hauling	0.0000	0.0000	0.0000	0.0000	0.0000	0.0000	0.0000	0.0000	0.0000	0.0000		0.0000	0.0000	0.0000	0.0000	0.0000
Vendor	0.0679	1.4141	0.4175	0.0112	0.4352	0.0192	0.4544	0.1252	0.0183	0.1435		1,174.992 4	1,174.992 4	3.0900e- 003	0.1603	1,222.833 7
Worker	1.9935	1.3011	21.3084	0.0488	5.3575	0.0239	5.3814	1.4204	0.0220	1.4424		4,928.162 3	4,928.162 3	0.0945	0.1126	4,964.089 8
Total	2.0614	2.7152	21.7258	0.0599	5.7927	0.0431	5.8357	1.5456	0.0404	1.5859		6,103.154 7	6,103.154 7	0.0976	0.2729	6,186.923 5

Northstar #1 Project - MITIGATED - Imperial County, Summer

EMFAC Off-Model Adjustment Factors for Gasoline Light Duty Vehicle to Account for the SAFE Vehicle Rule Not Applied

3.4 Building Construction - 2024

Unmitigated Construction On-Site

	ROG	NOx	CO	SO2	Fugitive PM10	Exhaust PM10	PM10 Total	Fugitive PM2.5	Exhaust PM2.5	PM2.5 Total	Bio- CO2	NBio- CO2	Total CO2	CH4	N2O	CO2e
Category	lb/day										lb/day					
Off-Road	5.0777	43.3618	50.9456	0.1122		1.9154	1.9154		1.7691	1.7691		10,766.99 65	10,766.99 65	3.4061		10,852.14 77
Total	5.0777	43.3618	50.9456	0.1122		1.9154	1.9154		1.7691	1.7691		10,766.99 65	10,766.99 65	3.4061		10,852.14 77

Unmitigated Construction Off-Site

	ROG	NOx	CO	SO2	Fugitive PM10	Exhaust PM10	PM10 Total	Fugitive PM2.5	Exhaust PM2.5	PM2.5 Total	Bio- CO2	NBio- CO2	Total CO2	CH4	N2O	CO2e
Category	lb/day										lb/day					
Hauling	0.0000	0.0000	0.0000	0.0000	0.0000	0.0000	0.0000	0.0000	0.0000	0.0000		0.0000	0.0000	0.0000	0.0000	0.0000
Vendor	0.0642	1.4085	0.3859	0.0110	0.4352	0.0191	0.4543	0.1252	0.0183	0.1435		1,159.037 0	1,159.037 0	2.9300e- 003	0.1572	1,205.964 9
Worker	1.8584	1.1452	19.5473	0.0473	5.3575	0.0227	5.3801	1.4204	0.0209	1.4413		4,779.992 3	4,779.992 3	0.0842	0.1032	4,812.858 9
Total	1.9226	2.5537	19.9332	0.0583	5.7927	0.0418	5.8344	1.5456	0.0392	1.5847		5,939.029 3	5,939.029 3	0.0872	0.2605	6,018.823 8

Northstar #1 Project - MITIGATED - Imperial County, Summer

EMFAC Off-Model Adjustment Factors for Gasoline Light Duty Vehicle to Account for the SAFE Vehicle Rule Not Applied

3.4 Building Construction - 2024

Mitigated Construction On-Site

	ROG	NOx	CO	SO2	Fugitive PM10	Exhaust PM10	PM10 Total	Fugitive PM2.5	Exhaust PM2.5	PM2.5 Total	Bio- CO2	NBio- CO2	Total CO2	CH4	N2O	CO2e
Category	lb/day										lb/day					
Off-Road	5.0777	43.3618	50.9456	0.1122		1.9154	1.9154		1.7691	1.7691	0.0000	10,766.99 64	10,766.99 64	3.4061		10,852.14 77
Total	5.0777	43.3618	50.9456	0.1122		1.9154	1.9154		1.7691	1.7691	0.0000	10,766.99 64	10,766.99 64	3.4061		10,852.14 77

Mitigated Construction Off-Site

	ROG	NOx	CO	SO2	Fugitive PM10	Exhaust PM10	PM10 Total	Fugitive PM2.5	Exhaust PM2.5	PM2.5 Total	Bio- CO2	NBio- CO2	Total CO2	CH4	N2O	CO2e
Category	lb/day										lb/day					
Hauling	0.0000	0.0000	0.0000	0.0000	0.0000	0.0000	0.0000	0.0000	0.0000	0.0000		0.0000	0.0000	0.0000	0.0000	0.0000
Vendor	0.0642	1.4085	0.3859	0.0110	0.4352	0.0191	0.4543	0.1252	0.0183	0.1435		1,159.037 0	1,159.037 0	2.9300e- 003	0.1572	1,205.964 9
Worker	1.8584	1.1452	19.5473	0.0473	5.3575	0.0227	5.3801	1.4204	0.0209	1.4413		4,779.992 3	4,779.992 3	0.0842	0.1032	4,812.858 9
Total	1.9226	2.5537	19.9332	0.0583	5.7927	0.0418	5.8344	1.5456	0.0392	1.5847		5,939.029 3	5,939.029 3	0.0872	0.2605	6,018.823 8

Northstar #1 Project - MITIGATED - Imperial County, Summer

EMFAC Off-Model Adjustment Factors for Gasoline Light Duty Vehicle to Account for the SAFE Vehicle Rule Not Applied

4.0 Operational Detail - Mobile

4.1 Mitigation Measures Mobile

	ROG	NOx	CO	SO2	Fugitive PM10	Exhaust PM10	PM10 Total	Fugitive PM2.5	Exhaust PM2.5	PM2.5 Total	Bio- CO2	NBio- CO2	Total CO2	CH4	N2O	CO2e
Category	lb/day										lb/day					
Mitigated	0.0138	0.7763	0.1503	4.8000e-003	3.5357	0.0114	3.5470	0.3805	0.0109	0.3914		508.9185	508.9185	1.1100e-003	0.0800	532.7858
Unmitigated	0.0138	0.7763	0.1503	4.8000e-003	3.5357	0.0114	3.5470	0.3805	0.0109	0.3914		508.9185	508.9185	1.1100e-003	0.0800	532.7858

4.2 Trip Summary Information

Land Use	Average Daily Trip Rate			Unmitigated	Mitigated
	Weekday	Saturday	Sunday	Annual VMT	Annual VMT
Other Non-Asphalt Surfaces	4.02	0.00	0.00	49,100	49,100
Total	4.02	0.00	0.00	49,100	49,100

4.3 Trip Type Information

Land Use	Miles			Trip %			Trip Purpose %		
	H-W or C-W	H-S or C-C	H-O or C-NW	H-W or C-W	H-S or C-C	H-O or C-NW	Primary	Diverted	Pass-by
Other Non-Asphalt Surfaces	47.00	47.00	47.00	0.00	100.00	0.00	100	0	0

4.4 Fleet Mix

Land Use	LDA	LDT1	LDT2	MDV	LHD1	LHD2	MHD	HHD	OBUS	UBUS	MCY	SBUS	MH
Other Non-Asphalt Surfaces	0.000000	0.000000	0.000000	0.000000	0.000000	0.000000	0.000000	1.000000	0.000000	0.000000	0.000000	0.000000	0.000000

Northstar #1 Project - MITIGATED - Imperial County, Summer

EMFAC Off-Model Adjustment Factors for Gasoline Light Duty Vehicle to Account for the SAFE Vehicle Rule Not Applied

5.0 Energy Detail

Historical Energy Use: N

5.1 Mitigation Measures Energy

	ROG	NOx	CO	SO2	Fugitive PM10	Exhaust PM10	PM10 Total	Fugitive PM2.5	Exhaust PM2.5	PM2.5 Total	Bio- CO2	NBio- CO2	Total CO2	CH4	N2O	CO2e	
Category	lb/day										lb/day						
NaturalGas Mitigated	0.0000	0.0000	0.0000	0.0000		0.0000	0.0000		0.0000	0.0000		0.0000	0.0000	0.0000	0.0000	0.0000	0.0000
NaturalGas Unmitigated	0.0000	0.0000	0.0000	0.0000		0.0000	0.0000		0.0000	0.0000		0.0000	0.0000	0.0000	0.0000	0.0000	0.0000

5.2 Energy by Land Use - NaturalGas

Unmitigated

	NaturalGas Use	ROG	NOx	CO	SO2	Fugitive PM10	Exhaust PM10	PM10 Total	Fugitive PM2.5	Exhaust PM2.5	PM2.5 Total	Bio- CO2	NBio- CO2	Total CO2	CH4	N2O	CO2e
Land Use	kBTU/yr	lb/day										lb/day					
Other Non-Asphalt Surfaces	0	0.0000	0.0000	0.0000	0.0000		0.0000	0.0000		0.0000	0.0000		0.0000	0.0000	0.0000	0.0000	0.0000
Total		0.0000	0.0000	0.0000	0.0000		0.0000	0.0000		0.0000	0.0000		0.0000	0.0000	0.0000	0.0000	0.0000

Northstar #1 Project - MITIGATED - Imperial County, Summer

EMFAC Off-Model Adjustment Factors for Gasoline Light Duty Vehicle to Account for the SAFE Vehicle Rule Not Applied

5.2 Energy by Land Use - NaturalGas

Mitigated

	NaturalGas Use	ROG	NOx	CO	SO2	Fugitive PM10	Exhaust PM10	PM10 Total	Fugitive PM2.5	Exhaust PM2.5	PM2.5 Total	Bio- CO2	NBio- CO2	Total CO2	CH4	N2O	CO2e
Land Use	kBTU/yr	lb/day										lb/day					
Other Non-Asphalt Surfaces	0	0.0000	0.0000	0.0000	0.0000		0.0000	0.0000		0.0000	0.0000		0.0000	0.0000	0.0000	0.0000	0.0000
Total		0.0000	0.0000	0.0000	0.0000		0.0000	0.0000		0.0000	0.0000		0.0000	0.0000	0.0000	0.0000	0.0000

6.0 Area Detail

6.1 Mitigation Measures Area

	ROG	NOx	CO	SO2	Fugitive PM10	Exhaust PM10	PM10 Total	Fugitive PM2.5	Exhaust PM2.5	PM2.5 Total	Bio- CO2	NBio- CO2	Total CO2	CH4	N2O	CO2e
Category	lb/day										lb/day					
Mitigated	5.8596	2.7000e-004	0.0293	0.0000		1.0000e-004	1.0000e-004		1.0000e-004	1.0000e-004		0.0628	0.0628	1.6000e-004		0.0669
Unmitigated	5.8596	2.7000e-004	0.0293	0.0000		1.0000e-004	1.0000e-004		1.0000e-004	1.0000e-004		0.0628	0.0628	1.6000e-004		0.0669

Northstar #1 Project - MITIGATED - Imperial County, Summer

EMFAC Off-Model Adjustment Factors for Gasoline Light Duty Vehicle to Account for the SAFE Vehicle Rule Not Applied

6.2 Area by SubCategory

Unmitigated

	ROG	NOx	CO	SO2	Fugitive PM10	Exhaust PM10	PM10 Total	Fugitive PM2.5	Exhaust PM2.5	PM2.5 Total	Bio- CO2	NBio- CO2	Total CO2	CH4	N2O	CO2e
SubCategory	lb/day										lb/day					
Architectural Coating	1.4288					0.0000	0.0000		0.0000	0.0000			0.0000			0.0000
Consumer Products	4.4281					0.0000	0.0000		0.0000	0.0000			0.0000			0.0000
Landscaping	2.7000e-003	2.7000e-004	0.0293	0.0000		1.0000e-004	1.0000e-004		1.0000e-004	1.0000e-004		0.0628	0.0628	1.6000e-004		0.0669
Total	5.8596	2.7000e-004	0.0293	0.0000		1.0000e-004	1.0000e-004		1.0000e-004	1.0000e-004		0.0628	0.0628	1.6000e-004		0.0669

Northstar #1 Project - MITIGATED - Imperial County, Summer

EMFAC Off-Model Adjustment Factors for Gasoline Light Duty Vehicle to Account for the SAFE Vehicle Rule Not Applied

6.2 Area by SubCategory

Mitigated

	ROG	NOx	CO	SO2	Fugitive PM10	Exhaust PM10	PM10 Total	Fugitive PM2.5	Exhaust PM2.5	PM2.5 Total	Bio- CO2	NBio- CO2	Total CO2	CH4	N2O	CO2e
SubCategory	lb/day										lb/day					
Architectural Coating	1.4288					0.0000	0.0000		0.0000	0.0000			0.0000			0.0000
Consumer Products	4.4281					0.0000	0.0000		0.0000	0.0000			0.0000			0.0000
Landscaping	2.7000e-003	2.7000e-004	0.0293	0.0000		1.0000e-004	1.0000e-004		1.0000e-004	1.0000e-004		0.0628	0.0628	1.6000e-004		0.0669
Total	5.8596	2.7000e-004	0.0293	0.0000		1.0000e-004	1.0000e-004		1.0000e-004	1.0000e-004		0.0628	0.0628	1.6000e-004		0.0669

7.0 Water Detail

7.1 Mitigation Measures Water

Northstar #1 Project - MITIGATED - Imperial County, Summer

EMFAC Off-Model Adjustment Factors for Gasoline Light Duty Vehicle to Account for the SAFE Vehicle Rule Not Applied

8.0 Waste Detail

8.1 Mitigation Measures Waste

9.0 Operational Offroad

Equipment Type	Number	Hours/Day	Days/Year	Horse Power	Load Factor	Fuel Type
----------------	--------	-----------	-----------	-------------	-------------	-----------

10.0 Stationary Equipment

Fire Pumps and Emergency Generators

Equipment Type	Number	Hours/Day	Hours/Year	Horse Power	Load Factor	Fuel Type
----------------	--------	-----------	------------	-------------	-------------	-----------

Boilers

Equipment Type	Number	Heat Input/Day	Heat Input/Year	Boiler Rating	Fuel Type
----------------	--------	----------------	-----------------	---------------	-----------

User Defined Equipment

Equipment Type	Number
----------------	--------

11.0 Vegetation

Northstar #1 Project - UNMITIGATED - Imperial County, Winter

EMFAC Off-Model Adjustment Factors for Gasoline Light Duty Vehicle to Account for the SAFE Vehicle Rule Not Applied

**Northstar #1 Project - UNMITIGATED
Imperial County, Winter**

1.0 Project Characteristics

1.1 Land Usage

Land Uses	Size	Metric	Lot Acreage	Floor Surface Area	Population
Other Non-Asphalt Surfaces	287.00	Acre	287.00	12,501,720.00	0

1.2 Other Project Characteristics

Urbanization	Rural	Wind Speed (m/s)	3.4	Precipitation Freq (Days)	12
Climate Zone	15	Operational Year		2024	
Utility Company	Imperial Irrigation District				
CO2 Intensity (lb/MWhr)	189.98	CH4 Intensity (lb/MWhr)	0.033	N2O Intensity (lb/MWhr)	0.004

1.3 User Entered Comments & Non-Default Data

Project Characteristics -

Land Use -

Construction Phase - Days of construction based on previous Z Global solar generation facility projects in Imperial County

Off-road Equipment - Equipment derived from previous Z Global solar generation facilities in Imperial County

Off-road Equipment - Ibid

Off-road Equipment - Ibid

Grading -

Construction Off-road Equipment Mitigation - ICAPCD Regulation VIII applied.

Vehicle Trips - Assume 4 heavy duty trucks trips daily

Trips and VMT - Maximum 75 workers assumed. Commute miles derived from an averaged distance between the Project Site and Brawley and the Project Site and Palm Springs [47 miles]

On-road Fugitive Dust - 1.15 miles of Project access is unpaved. Equates to 2.4 percent of 47 mile route.

Northstar #1 Project - UNMITIGATED - Imperial County, Winter

EMFAC Off-Model Adjustment Factors for Gasoline Light Duty Vehicle to Account for the SAFE Vehicle Rule Not Applied

Road Dust - 1.15 miles of site access unpaved. Equates to 2.4 percent of the route

Fleet Mix - Assume 100% heavy duty truck fleet mix

Table Name	Column Name	Default Value	New Value
tblConstructionPhase	NumDays	4,650.00	85.00
tblConstructionPhase	NumDays	465.00	120.00
tblConstructionPhase	NumDays	180.00	60.00
tblConstructionPhase	PhaseEndDate	10/22/2043	3/5/2024
tblConstructionPhase	PhaseEndDate	12/25/2025	11/7/2023
tblConstructionPhase	PhaseEndDate	3/14/2024	5/23/2023
tblConstructionPhase	PhaseStartDate	12/26/2025	11/8/2023
tblConstructionPhase	PhaseStartDate	3/15/2024	5/24/2023
tblConstructionPhase	PhaseStartDate	7/7/2023	3/1/2023
tblFleetMix	HHD	0.02	1.00
tblFleetMix	LDA	0.53	0.00
tblFleetMix	LDT1	0.06	0.00
tblFleetMix	LDT2	0.18	0.00
tblFleetMix	LHD1	0.03	0.00
tblFleetMix	LHD2	6.8510e-003	0.00
tblFleetMix	MCY	0.02	0.00
tblFleetMix	MDV	0.15	0.00
tblFleetMix	MH	3.5040e-003	0.00
tblFleetMix	MHD	8.3160e-003	0.00
tblFleetMix	OBUS	9.2500e-004	0.00
tblFleetMix	SBUS	7.6600e-004	0.00
tblFleetMix	UBUS	1.2000e-004	0.00
tblOffRoadEquipment	LoadFactor	0.38	0.38
tblOffRoadEquipment	LoadFactor	0.38	0.38
tblOffRoadEquipment	LoadFactor	0.38	0.38
tblOffRoadEquipment	LoadFactor	0.42	0.42

Northstar #1 Project - UNMITIGATED - Imperial County, Winter

EMFAC Off-Model Adjustment Factors for Gasoline Light Duty Vehicle to Account for the SAFE Vehicle Rule Not Applied

tblOffRoadEquipment	LoadFactor	0.36	0.36
tblOffRoadEquipment	LoadFactor	0.38	0.38
tblOffRoadEquipment	LoadFactor	0.40	0.40
tblOffRoadEquipment	LoadFactor	0.50	0.50
tblOffRoadEquipment	OffRoadEquipmentType		Off-Highway Trucks
tblOffRoadEquipment	OffRoadEquipmentType		Off-Highway Trucks
tblOffRoadEquipment	OffRoadEquipmentType		Off-Highway Trucks
tblOffRoadEquipment	OffRoadEquipmentType		Pavers
tblOffRoadEquipment	OffRoadEquipmentType		Paving Equipment
tblOffRoadEquipment	OffRoadEquipmentType		Plate Compactors
tblOffRoadEquipment	OffRoadEquipmentType		Rollers
tblOffRoadEquipment	OffRoadEquipmentType		Rough Terrain Forklifts
tblOffRoadEquipment	OffRoadEquipmentType		Trenchers
tblOffRoadEquipment	OffRoadEquipmentUnitAmount	2.00	4.00
tblOffRoadEquipment	OffRoadEquipmentUnitAmount	3.00	0.00
tblOffRoadEquipment	OffRoadEquipmentUnitAmount	1.00	0.00
tblOffRoadEquipment	OffRoadEquipmentUnitAmount	1.00	3.00
tblOffRoadEquipment	OffRoadEquipmentUnitAmount	1.00	2.00
tblOffRoadEquipment	OffRoadEquipmentUnitAmount	3.00	2.00
tblOffRoadEquipment	OffRoadEquipmentUnitAmount	3.00	4.00
tblOffRoadEquipment	OffRoadEquipmentUnitAmount	2.00	4.00
tblOffRoadEquipment	OffRoadEquipmentUnitAmount	4.00	2.00
tblOnRoadDust	VendorPercentPave	50.00	97.60
tblOnRoadDust	WorkerPercentPave	50.00	97.60
tblOnRoadDust	WorkerPercentPave	50.00	97.60
tblOnRoadDust	WorkerPercentPave	50.00	97.60
tblProjectCharacteristics	UrbanizationLevel	Urban	Rural
tblRoadDust	RoadPercentPave	50	97.6
tblTripsAndVMT	VendorTripLength	11.90	47.00

Northstar #1 Project - UNMITIGATED - Imperial County, Winter

EMFAC Off-Model Adjustment Factors for Gasoline Light Duty Vehicle to Account for the SAFE Vehicle Rule Not Applied

tblTripsAndVMT	VendorTripNumber	2,049.00	10.00
tblTripsAndVMT	WorkerTripLength	10.20	47.00
tblTripsAndVMT	WorkerTripLength	10.20	47.00
tblTripsAndVMT	WorkerTripLength	10.20	47.00
tblTripsAndVMT	WorkerTripNumber	5,251.00	150.00
tblVehicleTrips	CC_TL	9.50	47.00
tblVehicleTrips	CC_TTP	0.00	100.00
tblVehicleTrips	CNW_TL	11.90	47.00
tblVehicleTrips	CW_TL	16.40	47.00
tblVehicleTrips	PR_TP	0.00	100.00
tblVehicleTrips	WD_TR	0.00	0.01

2.0 Emissions Summary

Northstar #1 Project - UNMITIGATED - Imperial County, Winter

EMFAC Off-Model Adjustment Factors for Gasoline Light Duty Vehicle to Account for the SAFE Vehicle Rule Not Applied

2.1 Overall Construction (Maximum Daily Emission)

Unmitigated Construction

	ROG	NOx	CO	SO2	Fugitive PM10	Exhaust PM10	PM10 Total	Fugitive PM2.5	Exhaust PM2.5	PM2.5 Total	Bio- CO2	NBio- CO2	Total CO2	CH4	N2O	CO2e
Year	lb/day										lb/day					
2023	7.1103	61.0704	65.6535	0.1646	271.2819	2.4862	273.3904	28.0207	2.2873	29.9688	0.0000	16,118.03 51	16,118.03 51	3.5822	0.2775	16,287.98 88
2024	6.8421	46.1363	64.2752	0.1633	271.2819	1.9571	273.2390	28.0207	1.8082	29.8289	0.0000	15,980.34 25	15,980.34 25	3.4807	0.2646	16,146.19 98
Maximum	7.1103	61.0704	65.6535	0.1646	271.2819	2.4862	273.3904	28.0207	2.2873	29.9688	0.0000	16,118.03 51	16,118.03 51	3.5822	0.2775	16,287.98 88

Mitigated Construction

	ROG	NOx	CO	SO2	Fugitive PM10	Exhaust PM10	PM10 Total	Fugitive PM2.5	Exhaust PM2.5	PM2.5 Total	Bio- CO2	NBio- CO2	Total CO2	CH4	N2O	CO2e
Year	lb/day										lb/day					
2023	7.1103	61.0704	65.6535	0.1646	271.2819	2.4862	273.3904	28.0207	2.2873	29.9688	0.0000	16,118.03 51	16,118.03 51	3.5822	0.2775	16,287.98 88
2024	6.8421	46.1363	64.2752	0.1633	271.2819	1.9571	273.2390	28.0207	1.8082	29.8289	0.0000	15,980.34 25	15,980.34 25	3.4807	0.2646	16,146.19 98
Maximum	7.1103	61.0704	65.6535	0.1646	271.2819	2.4862	273.3904	28.0207	2.2873	29.9688	0.0000	16,118.03 51	16,118.03 51	3.5822	0.2775	16,287.98 88

Northstar #1 Project - UNMITIGATED - Imperial County, Winter

EMFAC Off-Model Adjustment Factors for Gasoline Light Duty Vehicle to Account for the SAFE Vehicle Rule Not Applied

2.2 Overall Operational

Unmitigated Operational

	ROG	NOx	CO	SO2	Fugitive PM10	Exhaust PM10	PM10 Total	Fugitive PM2.5	Exhaust PM2.5	PM2.5 Total	Bio- CO2	NBio- CO2	Total CO2	CH4	N2O	CO2e
Category	lb/day										lb/day					
Area	5.8596	2.7000e-004	0.0293	0.0000		1.0000e-004	1.0000e-004		1.0000e-004	1.0000e-004		0.0628	0.0628	1.6000e-004		0.0669
Energy	0.0000	0.0000	0.0000	0.0000		0.0000	0.0000		0.0000	0.0000		0.0000	0.0000	0.0000	0.0000	0.0000
Mobile	0.0129	0.8587	0.1530	4.8100e-003	3.5357	0.0114	3.5471	0.3805	0.0109	0.3914		509.3617	509.3617	1.0700e-003	0.0801	533.2495
Total	5.8725	0.8589	0.1823	4.8100e-003	3.5357	0.0115	3.5472	0.3805	0.0110	0.3915		509.4245	509.4245	1.2300e-003	0.0801	533.3165

Mitigated Operational

	ROG	NOx	CO	SO2	Fugitive PM10	Exhaust PM10	PM10 Total	Fugitive PM2.5	Exhaust PM2.5	PM2.5 Total	Bio- CO2	NBio- CO2	Total CO2	CH4	N2O	CO2e
Category	lb/day										lb/day					
Area	5.8596	2.7000e-004	0.0293	0.0000		1.0000e-004	1.0000e-004		1.0000e-004	1.0000e-004		0.0628	0.0628	1.6000e-004		0.0669
Energy	0.0000	0.0000	0.0000	0.0000		0.0000	0.0000		0.0000	0.0000		0.0000	0.0000	0.0000	0.0000	0.0000
Mobile	0.0129	0.8587	0.1530	4.8100e-003	3.5357	0.0114	3.5471	0.3805	0.0109	0.3914		509.3617	509.3617	1.0700e-003	0.0801	533.2495
Total	5.8725	0.8589	0.1823	4.8100e-003	3.5357	0.0115	3.5472	0.3805	0.0110	0.3915		509.4245	509.4245	1.2300e-003	0.0801	533.3165

Northstar #1 Project - UNMITIGATED - Imperial County, Winter

EMFAC Off-Model Adjustment Factors for Gasoline Light Duty Vehicle to Account for the SAFE Vehicle Rule Not Applied

	ROG	NOx	CO	SO2	Fugitive PM10	Exhaust PM10	PM10 Total	Fugitive PM2.5	Exhaust PM2.5	PM2.5 Total	Bio- CO2	NBio-CO2	Total CO2	CH4	N2O	CO2e
Percent Reduction	0.00	0.00	0.00	0.00	0.00	0.00	0.00	0.00	0.00	0.00	0.00	0.00	0.00	0.00	0.00	0.00

3.0 Construction Detail

Construction Phase

Phase Number	Phase Name	Phase Type	Start Date	End Date	Num Days Week	Num Days	Phase Description
1	Site Preparation	Site Preparation	3/1/2023	5/23/2023	5	60	
2	Grading	Grading	5/24/2023	11/7/2023	5	120	
3	Building Construction	Building Construction	11/8/2023	3/5/2024	5	85	

Acres of Grading (Site Preparation Phase): 60

Acres of Grading (Grading Phase): 540

Acres of Paving: 287

Residential Indoor: 0; Residential Outdoor: 0; Non-Residential Indoor: 0; Non-Residential Outdoor: 0; Striped Parking Area: 0 (Architectural Coating – sqft)

OffRoad Equipment

Phase Name	Offroad Equipment Type	Amount	Usage Hours	Horse Power	Load Factor
Site Preparation	Off-Highway Trucks	1	8.00	402	0.38
Grading	Off-Highway Trucks	1	8.00	402	0.38
Building Construction	Cranes	1	7.00	231	0.29
Building Construction	Off-Highway Trucks	4	8.00	402	0.38
Grading	Excavators	4	8.00	158	0.38
Building Construction	Forklifts	0	8.00	89	0.20
Building Construction	Generator Sets	0	8.00	84	0.74
Grading	Graders	3	8.00	187	0.41

Northstar #1 Project - UNMITIGATED - Imperial County, Winter

EMFAC Off-Model Adjustment Factors for Gasoline Light Duty Vehicle to Account for the SAFE Vehicle Rule Not Applied

Building Construction	Pavers	1	8.00	130	0.42
Building Construction	Paving Equipment	2	8.00	132	0.36
Building Construction	Plate Compactors	4	8.00	8	0.43
Building Construction	Rollers	2	8.00	80	0.38
Grading	Rubber Tired Dozers	2	8.00	247	0.40
Site Preparation	Rubber Tired Dozers	2	8.00	247	0.40
Grading	Scrapers	2	8.00	367	0.48
Building Construction	Tractors/Loaders/Backhoes	4	7.00	97	0.37
Grading	Tractors/Loaders/Backhoes	4	8.00	97	0.37
Site Preparation	Tractors/Loaders/Backhoes	2	8.00	97	0.37
Building Construction	Welders	1	8.00	46	0.45
Building Construction	Rough Terrain Forklifts	4	8.00	100	0.40
Building Construction	Trenchers	2	8.00	78	0.50

Trips and VMT

Phase Name	Offroad Equipment Count	Worker Trip Number	Vendor Trip Number	Hauling Trip Number	Worker Trip Length	Vendor Trip Length	Hauling Trip Length	Worker Vehicle Class	Vendor Vehicle Class	Hauling Vehicle Class
Site Preparation	5	13.00	0.00	0.00	47.00	11.90	20.00	LD_Mix	HDT_Mix	HHDT
Grading	16	40.00	0.00	0.00	47.00	11.90	20.00	LD_Mix	HDT_Mix	HHDT
Building Construction	25	150.00	10.00	0.00	47.00	47.00	20.00	LD_Mix	HDT_Mix	HHDT

3.1 Mitigation Measures Construction

Water Exposed Area

Reduce Vehicle Speed on Unpaved Roads

Northstar #1 Project - UNMITIGATED - Imperial County, Winter

EMFAC Off-Model Adjustment Factors for Gasoline Light Duty Vehicle to Account for the SAFE Vehicle Rule Not Applied

3.2 Site Preparation - 2023

Unmitigated Construction On-Site

	ROG	NOx	CO	SO2	Fugitive PM10	Exhaust PM10	PM10 Total	Fugitive PM2.5	Exhaust PM2.5	PM2.5 Total	Bio- CO2	NBio- CO2	Total CO2	CH4	N2O	CO2e
Category	lb/day										lb/day					
Fugitive Dust					13.1047	0.0000	13.1047	6.7350	0.0000	6.7350			0.0000			0.0000
Off-Road	2.1784	20.9114	13.9803	0.0366		0.9231	0.9231		0.8493	0.8493		3,543.4424	3,543.4424	1.1460		3,572.0929
Total	2.1784	20.9114	13.9803	0.0366	13.1047	0.9231	14.0278	6.7350	0.8493	7.5842		3,543.4424	3,543.4424	1.1460		3,572.0929

Unmitigated Construction Off-Site

	ROG	NOx	CO	SO2	Fugitive PM10	Exhaust PM10	PM10 Total	Fugitive PM2.5	Exhaust PM2.5	PM2.5 Total	Bio- CO2	NBio- CO2	Total CO2	CH4	N2O	CO2e
Category	lb/day										lb/day					
Hauling	0.0000	0.0000	0.0000	0.0000	0.0000	0.0000	0.0000	0.0000	0.0000	0.0000		0.0000	0.0000	0.0000	0.0000	0.0000
Vendor	0.0000	0.0000	0.0000	0.0000	0.0000	0.0000	0.0000	0.0000	0.0000	0.0000		0.0000	0.0000	0.0000	0.0000	0.0000
Worker	0.1572	0.1194	1.2241	3.5800e-003	22.0353	2.0700e-003	22.0374	2.2742	1.9100e-003	2.2761		362.0667	362.0667	6.9500e-003	0.0101	365.2545
Total	0.1572	0.1194	1.2241	3.5800e-003	22.0353	2.0700e-003	22.0374	2.2742	1.9100e-003	2.2761		362.0667	362.0667	6.9500e-003	0.0101	365.2545

Northstar #1 Project - UNMITIGATED - Imperial County, Winter

EMFAC Off-Model Adjustment Factors for Gasoline Light Duty Vehicle to Account for the SAFE Vehicle Rule Not Applied

3.2 Site Preparation - 2023

Mitigated Construction On-Site

	ROG	NOx	CO	SO2	Fugitive PM10	Exhaust PM10	PM10 Total	Fugitive PM2.5	Exhaust PM2.5	PM2.5 Total	Bio- CO2	NBio- CO2	Total CO2	CH4	N2O	CO2e
Category	lb/day										lb/day					
Fugitive Dust					5.8971	0.0000	5.8971	3.0307	0.0000	3.0307			0.0000			0.0000
Off-Road	2.1784	20.9114	13.9803	0.0366		0.9231	0.9231		0.8493	0.8493	0.0000	3,543.442 3	3,543.442 3	1.1460		3,572.092 9
Total	2.1784	20.9114	13.9803	0.0366	5.8971	0.9231	6.8202	3.0307	0.8493	3.8800	0.0000	3,543.442 3	3,543.442 3	1.1460		3,572.092 9

Mitigated Construction Off-Site

	ROG	NOx	CO	SO2	Fugitive PM10	Exhaust PM10	PM10 Total	Fugitive PM2.5	Exhaust PM2.5	PM2.5 Total	Bio- CO2	NBio- CO2	Total CO2	CH4	N2O	CO2e
Category	lb/day										lb/day					
Hauling	0.0000	0.0000	0.0000	0.0000	0.0000	0.0000	0.0000	0.0000	0.0000	0.0000		0.0000	0.0000	0.0000	0.0000	0.0000
Vendor	0.0000	0.0000	0.0000	0.0000	0.0000	0.0000	0.0000	0.0000	0.0000	0.0000		0.0000	0.0000	0.0000	0.0000	0.0000
Worker	0.1572	0.1194	1.2241	3.5800e-003	22.0353	2.0700e-003	22.0374	2.2742	1.9100e-003	2.2761		362.0667	362.0667	6.9500e-003	0.0101	365.2545
Total	0.1572	0.1194	1.2241	3.5800e-003	22.0353	2.0700e-003	22.0374	2.2742	1.9100e-003	2.2761		362.0667	362.0667	6.9500e-003	0.0101	365.2545

Northstar #1 Project - UNMITIGATED - Imperial County, Winter

EMFAC Off-Model Adjustment Factors for Gasoline Light Duty Vehicle to Account for the SAFE Vehicle Rule Not Applied

3.3 Grading - 2023

Unmitigated Construction On-Site

	ROG	NOx	CO	SO2	Fugitive PM10	Exhaust PM10	PM10 Total	Fugitive PM2.5	Exhaust PM2.5	PM2.5 Total	Bio- CO2	NBio- CO2	Total CO2	CH4	N2O	CO2e
Category	lb/day										lb/day					
Fugitive Dust					16.8164	0.0000	16.8164	7.1358	0.0000	7.1358			0.0000			0.0000
Off-Road	5.9598	60.7032	48.8259	0.1137		2.4798	2.4798		2.2814	2.2814		11,009.84 10	11,009.84 10	3.5608		11,098.86 11
Total	5.9598	60.7032	48.8259	0.1137	16.8164	2.4798	19.2962	7.1358	2.2814	9.4172		11,009.84 10	11,009.84 10	3.5608		11,098.86 11

Unmitigated Construction Off-Site

	ROG	NOx	CO	SO2	Fugitive PM10	Exhaust PM10	PM10 Total	Fugitive PM2.5	Exhaust PM2.5	PM2.5 Total	Bio- CO2	NBio- CO2	Total CO2	CH4	N2O	CO2e
Category	lb/day										lb/day					
Hauling	0.0000	0.0000	0.0000	0.0000	0.0000	0.0000	0.0000	0.0000	0.0000	0.0000		0.0000	0.0000	0.0000	0.0000	0.0000
Vendor	0.0000	0.0000	0.0000	0.0000	0.0000	0.0000	0.0000	0.0000	0.0000	0.0000		0.0000	0.0000	0.0000	0.0000	0.0000
Worker	0.4836	0.3673	3.7664	0.0110	67.8010	6.3800e-003	67.8073	6.9975	5.8700e-003	7.0034		1,114.051 5	1,114.051 5	0.0214	0.0311	1,123.859 9
Total	0.4836	0.3673	3.7664	0.0110	67.8010	6.3800e-003	67.8073	6.9975	5.8700e-003	7.0034		1,114.051 5	1,114.051 5	0.0214	0.0311	1,123.859 9

Northstar #1 Project - UNMITIGATED - Imperial County, Winter

EMFAC Off-Model Adjustment Factors for Gasoline Light Duty Vehicle to Account for the SAFE Vehicle Rule Not Applied

3.3 Grading - 2023

Mitigated Construction On-Site

	ROG	NOx	CO	SO2	Fugitive PM10	Exhaust PM10	PM10 Total	Fugitive PM2.5	Exhaust PM2.5	PM2.5 Total	Bio- CO2	NBio- CO2	Total CO2	CH4	N2O	CO2e
Category	lb/day										lb/day					
Fugitive Dust					7.5674	0.0000	7.5674	3.2111	0.0000	3.2111			0.0000			0.0000
Off-Road	5.9598	60.7032	48.8259	0.1137		2.4798	2.4798		2.2814	2.2814	0.0000	11,009.84 10	11,009.84 10	3.5608		11,098.86 11
Total	5.9598	60.7032	48.8259	0.1137	7.5674	2.4798	10.0472	3.2111	2.2814	5.4925	0.0000	11,009.84 10	11,009.84 10	3.5608		11,098.86 11

Mitigated Construction Off-Site

	ROG	NOx	CO	SO2	Fugitive PM10	Exhaust PM10	PM10 Total	Fugitive PM2.5	Exhaust PM2.5	PM2.5 Total	Bio- CO2	NBio- CO2	Total CO2	CH4	N2O	CO2e
Category	lb/day										lb/day					
Hauling	0.0000	0.0000	0.0000	0.0000	0.0000	0.0000	0.0000	0.0000	0.0000	0.0000		0.0000	0.0000	0.0000	0.0000	0.0000
Vendor	0.0000	0.0000	0.0000	0.0000	0.0000	0.0000	0.0000	0.0000	0.0000	0.0000		0.0000	0.0000	0.0000	0.0000	0.0000
Worker	0.4836	0.3673	3.7664	0.0110	67.8010	6.3800e-003	67.8073	6.9975	5.8700e-003	7.0034		1,114.051 5	1,114.051 5	0.0214	0.0311	1,123.859 9
Total	0.4836	0.3673	3.7664	0.0110	67.8010	6.3800e-003	67.8073	6.9975	5.8700e-003	7.0034		1,114.051 5	1,114.051 5	0.0214	0.0311	1,123.859 9

Northstar #1 Project - UNMITIGATED - Imperial County, Winter

EMFAC Off-Model Adjustment Factors for Gasoline Light Duty Vehicle to Account for the SAFE Vehicle Rule Not Applied

3.4 Building Construction - 2023

Unmitigated Construction On-Site

	ROG	NOx	CO	SO2	Fugitive PM10	Exhaust PM10	PM10 Total	Fugitive PM2.5	Exhaust PM2.5	PM2.5 Total	Bio- CO2	NBio- CO2	Total CO2	CH4	N2O	CO2e
Category	lb/day										lb/day					
Off-Road	5.2299	45.8103	51.1124	0.1121		2.0654	2.0654		1.9077	1.9077		10,764.8165	10,764.8165	3.4068		10,849.9866
Total	5.2299	45.8103	51.1124	0.1121		2.0654	2.0654		1.9077	1.9077		10,764.8165	10,764.8165	3.4068		10,849.9866

Unmitigated Construction Off-Site

	ROG	NOx	CO	SO2	Fugitive PM10	Exhaust PM10	PM10 Total	Fugitive PM2.5	Exhaust PM2.5	PM2.5 Total	Bio- CO2	NBio- CO2	Total CO2	CH4	N2O	CO2e
Category	lb/day										lb/day					
Hauling	0.0000	0.0000	0.0000	0.0000	0.0000	0.0000	0.0000	0.0000	0.0000	0.0000		0.0000	0.0000	0.0000	0.0000	0.0000
Vendor	0.0670	1.5719	0.4173	0.0112	17.0283	0.0192	17.0475	1.7799	0.0183	1.7982		1,175.5256	1,175.5256	3.0000e-003	0.1608	1,223.5274
Worker	1.8134	1.3772	14.1239	0.0413	254.2536	0.0239	254.2775	26.2408	0.0220	26.2628		4,177.6930	4,177.6930	0.0802	0.1167	4,214.4748
Total	1.8804	2.9490	14.5411	0.0525	271.2819	0.0431	271.3250	28.0207	0.0404	28.0610		5,353.2186	5,353.2186	0.0832	0.2775	5,438.0021

Northstar #1 Project - UNMITIGATED - Imperial County, Winter

EMFAC Off-Model Adjustment Factors for Gasoline Light Duty Vehicle to Account for the SAFE Vehicle Rule Not Applied

3.4 Building Construction - 2023

Mitigated Construction On-Site

	ROG	NOx	CO	SO2	Fugitive PM10	Exhaust PM10	PM10 Total	Fugitive PM2.5	Exhaust PM2.5	PM2.5 Total	Bio- CO2	NBio- CO2	Total CO2	CH4	N2O	CO2e
Category	lb/day										lb/day					
Off-Road	5.2299	45.8103	51.1124	0.1121		2.0654	2.0654		1.9077	1.9077	0.0000	10,764.81 65	10,764.81 65	3.4068		10,849.98 66
Total	5.2299	45.8103	51.1124	0.1121		2.0654	2.0654		1.9077	1.9077	0.0000	10,764.81 65	10,764.81 65	3.4068		10,849.98 66

Mitigated Construction Off-Site

	ROG	NOx	CO	SO2	Fugitive PM10	Exhaust PM10	PM10 Total	Fugitive PM2.5	Exhaust PM2.5	PM2.5 Total	Bio- CO2	NBio- CO2	Total CO2	CH4	N2O	CO2e
Category	lb/day										lb/day					
Hauling	0.0000	0.0000	0.0000	0.0000	0.0000	0.0000	0.0000	0.0000	0.0000	0.0000		0.0000	0.0000	0.0000	0.0000	0.0000
Vendor	0.0670	1.5719	0.4173	0.0112	17.0283	0.0192	17.0475	1.7799	0.0183	1.7982		1,175.525 6	1,175.525 6	3.0000e- 003	0.1608	1,223.527 4
Worker	1.8134	1.3772	14.1239	0.0413	254.2536	0.0239	254.2775	26.2408	0.0220	26.2628		4,177.693 0	4,177.693 0	0.0802	0.1167	4,214.474 8
Total	1.8804	2.9490	14.5411	0.0525	271.2819	0.0431	271.3250	28.0207	0.0404	28.0610		5,353.218 6	5,353.218 6	0.0832	0.2775	5,438.002 1

Northstar #1 Project - UNMITIGATED - Imperial County, Winter

EMFAC Off-Model Adjustment Factors for Gasoline Light Duty Vehicle to Account for the SAFE Vehicle Rule Not Applied

3.4 Building Construction - 2024

Unmitigated Construction On-Site

	ROG	NOx	CO	SO2	Fugitive PM10	Exhaust PM10	PM10 Total	Fugitive PM2.5	Exhaust PM2.5	PM2.5 Total	Bio- CO2	NBio- CO2	Total CO2	CH4	N2O	CO2e
Category	lb/day										lb/day					
Off-Road	5.0777	43.3618	50.9456	0.1122		1.9154	1.9154		1.7691	1.7691		10,766.99 65	10,766.99 65	3.4061		10,852.14 77
Total	5.0777	43.3618	50.9456	0.1122		1.9154	1.9154		1.7691	1.7691		10,766.99 65	10,766.99 65	3.4061		10,852.14 77

Unmitigated Construction Off-Site

	ROG	NOx	CO	SO2	Fugitive PM10	Exhaust PM10	PM10 Total	Fugitive PM2.5	Exhaust PM2.5	PM2.5 Total	Bio- CO2	NBio- CO2	Total CO2	CH4	N2O	CO2e
Category	lb/day										lb/day					
Hauling	0.0000	0.0000	0.0000	0.0000	0.0000	0.0000	0.0000	0.0000	0.0000	0.0000		0.0000	0.0000	0.0000	0.0000	0.0000
Vendor	0.0634	1.5647	0.3872	0.0110	17.0283	0.0191	17.0474	1.7799	0.0183	1.7982		1,159.572 6	1,159.572 6	2.8500e- 003	0.1577	1,206.647 6
Worker	1.7010	1.2098	12.9425	0.0401	254.2536	0.0227	254.2763	26.2408	0.0209	26.2617		4,053.773 4	4,053.773 4	0.0718	0.1068	4,087.404 6
Total	1.7644	2.7745	13.3296	0.0511	271.2819	0.0418	271.3237	28.0207	0.0392	28.0598		5,213.346 0	5,213.346 0	0.0747	0.2646	5,294.052 1

Northstar #1 Project - UNMITIGATED - Imperial County, Winter

EMFAC Off-Model Adjustment Factors for Gasoline Light Duty Vehicle to Account for the SAFE Vehicle Rule Not Applied

3.4 Building Construction - 2024

Mitigated Construction On-Site

	ROG	NOx	CO	SO2	Fugitive PM10	Exhaust PM10	PM10 Total	Fugitive PM2.5	Exhaust PM2.5	PM2.5 Total	Bio- CO2	NBio- CO2	Total CO2	CH4	N2O	CO2e
Category	lb/day										lb/day					
Off-Road	5.0777	43.3618	50.9456	0.1122		1.9154	1.9154		1.7691	1.7691	0.0000	10,766.99 64	10,766.99 64	3.4061		10,852.14 77
Total	5.0777	43.3618	50.9456	0.1122		1.9154	1.9154		1.7691	1.7691	0.0000	10,766.99 64	10,766.99 64	3.4061		10,852.14 77

Mitigated Construction Off-Site

	ROG	NOx	CO	SO2	Fugitive PM10	Exhaust PM10	PM10 Total	Fugitive PM2.5	Exhaust PM2.5	PM2.5 Total	Bio- CO2	NBio- CO2	Total CO2	CH4	N2O	CO2e
Category	lb/day										lb/day					
Hauling	0.0000	0.0000	0.0000	0.0000	0.0000	0.0000	0.0000	0.0000	0.0000	0.0000		0.0000	0.0000	0.0000	0.0000	0.0000
Vendor	0.0634	1.5647	0.3872	0.0110	17.0283	0.0191	17.0474	1.7799	0.0183	1.7982		1,159.572 6	1,159.572 6	2.8500e- 003	0.1577	1,206.647 6
Worker	1.7010	1.2098	12.9425	0.0401	254.2536	0.0227	254.2763	26.2408	0.0209	26.2617		4,053.773 4	4,053.773 4	0.0718	0.1068	4,087.404 6
Total	1.7644	2.7745	13.3296	0.0511	271.2819	0.0418	271.3237	28.0207	0.0392	28.0598		5,213.346 0	5,213.346 0	0.0747	0.2646	5,294.052 1

Northstar #1 Project - UNMITIGATED - Imperial County, Winter

EMFAC Off-Model Adjustment Factors for Gasoline Light Duty Vehicle to Account for the SAFE Vehicle Rule Not Applied

4.0 Operational Detail - Mobile

4.1 Mitigation Measures Mobile

	ROG	NOx	CO	SO2	Fugitive PM10	Exhaust PM10	PM10 Total	Fugitive PM2.5	Exhaust PM2.5	PM2.5 Total	Bio- CO2	NBio- CO2	Total CO2	CH4	N2O	CO2e
Category	lb/day										lb/day					
Mitigated	0.0129	0.8587	0.1530	4.8100e-003	3.5357	0.0114	3.5471	0.3805	0.0109	0.3914		509.3617	509.3617	1.0700e-003	0.0801	533.2495
Unmitigated	0.0129	0.8587	0.1530	4.8100e-003	3.5357	0.0114	3.5471	0.3805	0.0109	0.3914		509.3617	509.3617	1.0700e-003	0.0801	533.2495

4.2 Trip Summary Information

Land Use	Average Daily Trip Rate			Unmitigated	Mitigated
	Weekday	Saturday	Sunday	Annual VMT	Annual VMT
Other Non-Asphalt Surfaces	4.02	0.00	0.00	49,100	49,100
Total	4.02	0.00	0.00	49,100	49,100

4.3 Trip Type Information

Land Use	Miles			Trip %			Trip Purpose %		
	H-W or C-W	H-S or C-C	H-O or C-NW	H-W or C-W	H-S or C-C	H-O or C-NW	Primary	Diverted	Pass-by
Other Non-Asphalt Surfaces	47.00	47.00	47.00	0.00	100.00	0.00	100	0	0

4.4 Fleet Mix

Land Use	LDA	LDT1	LDT2	MDV	LHD1	LHD2	MHD	HHD	OBUS	UBUS	MCY	SBUS	MH
Other Non-Asphalt Surfaces	0.000000	0.000000	0.000000	0.000000	0.000000	0.000000	0.000000	1.000000	0.000000	0.000000	0.000000	0.000000	0.000000

Northstar #1 Project - UNMITIGATED - Imperial County, Winter

EMFAC Off-Model Adjustment Factors for Gasoline Light Duty Vehicle to Account for the SAFE Vehicle Rule Not Applied

5.0 Energy Detail

Historical Energy Use: N

5.1 Mitigation Measures Energy

	ROG	NOx	CO	SO2	Fugitive PM10	Exhaust PM10	PM10 Total	Fugitive PM2.5	Exhaust PM2.5	PM2.5 Total	Bio- CO2	NBio- CO2	Total CO2	CH4	N2O	CO2e
Category	lb/day										lb/day					
NaturalGas Mitigated	0.0000	0.0000	0.0000	0.0000		0.0000	0.0000		0.0000	0.0000		0.0000	0.0000	0.0000	0.0000	0.0000
NaturalGas Unmitigated	0.0000	0.0000	0.0000	0.0000		0.0000	0.0000		0.0000	0.0000		0.0000	0.0000	0.0000	0.0000	0.0000

5.2 Energy by Land Use - NaturalGas

Unmitigated

	NaturalGas Use	ROG	NOx	CO	SO2	Fugitive PM10	Exhaust PM10	PM10 Total	Fugitive PM2.5	Exhaust PM2.5	PM2.5 Total	Bio- CO2	NBio- CO2	Total CO2	CH4	N2O	CO2e
Land Use	kBTU/yr	lb/day										lb/day					
Other Non-Asphalt Surfaces	0	0.0000	0.0000	0.0000	0.0000		0.0000	0.0000		0.0000	0.0000		0.0000	0.0000	0.0000	0.0000	0.0000
Total		0.0000	0.0000	0.0000	0.0000		0.0000	0.0000		0.0000	0.0000		0.0000	0.0000	0.0000	0.0000	0.0000

Northstar #1 Project - UNMITIGATED - Imperial County, Winter

EMFAC Off-Model Adjustment Factors for Gasoline Light Duty Vehicle to Account for the SAFE Vehicle Rule Not Applied

5.2 Energy by Land Use - NaturalGas

Mitigated

	NaturalGas Use	ROG	NOx	CO	SO2	Fugitive PM10	Exhaust PM10	PM10 Total	Fugitive PM2.5	Exhaust PM2.5	PM2.5 Total	Bio- CO2	NBio- CO2	Total CO2	CH4	N2O	CO2e
Land Use	kBTU/yr	lb/day										lb/day					
Other Non-Asphalt Surfaces	0	0.0000	0.0000	0.0000	0.0000		0.0000	0.0000		0.0000	0.0000		0.0000	0.0000	0.0000	0.0000	0.0000
Total		0.0000	0.0000	0.0000	0.0000		0.0000	0.0000		0.0000	0.0000		0.0000	0.0000	0.0000	0.0000	0.0000

6.0 Area Detail

6.1 Mitigation Measures Area

	ROG	NOx	CO	SO2	Fugitive PM10	Exhaust PM10	PM10 Total	Fugitive PM2.5	Exhaust PM2.5	PM2.5 Total	Bio- CO2	NBio- CO2	Total CO2	CH4	N2O	CO2e
Category	lb/day										lb/day					
Mitigated	5.8596	2.7000e-004	0.0293	0.0000		1.0000e-004	1.0000e-004		1.0000e-004	1.0000e-004		0.0628	0.0628	1.6000e-004		0.0669
Unmitigated	5.8596	2.7000e-004	0.0293	0.0000		1.0000e-004	1.0000e-004		1.0000e-004	1.0000e-004		0.0628	0.0628	1.6000e-004		0.0669

Northstar #1 Project - UNMITIGATED - Imperial County, Winter

EMFAC Off-Model Adjustment Factors for Gasoline Light Duty Vehicle to Account for the SAFE Vehicle Rule Not Applied

6.2 Area by SubCategory

Unmitigated

	ROG	NOx	CO	SO2	Fugitive PM10	Exhaust PM10	PM10 Total	Fugitive PM2.5	Exhaust PM2.5	PM2.5 Total	Bio- CO2	NBio- CO2	Total CO2	CH4	N2O	CO2e
SubCategory	lb/day										lb/day					
Architectural Coating	1.4288					0.0000	0.0000		0.0000	0.0000			0.0000			0.0000
Consumer Products	4.4281					0.0000	0.0000		0.0000	0.0000			0.0000			0.0000
Landscaping	2.7000e-003	2.7000e-004	0.0293	0.0000		1.0000e-004	1.0000e-004		1.0000e-004	1.0000e-004		0.0628	0.0628	1.6000e-004		0.0669
Total	5.8596	2.7000e-004	0.0293	0.0000		1.0000e-004	1.0000e-004		1.0000e-004	1.0000e-004		0.0628	0.0628	1.6000e-004		0.0669

Northstar #1 Project - UNMITIGATED - Imperial County, Winter

EMFAC Off-Model Adjustment Factors for Gasoline Light Duty Vehicle to Account for the SAFE Vehicle Rule Not Applied

6.2 Area by SubCategory

Mitigated

	ROG	NOx	CO	SO2	Fugitive PM10	Exhaust PM10	PM10 Total	Fugitive PM2.5	Exhaust PM2.5	PM2.5 Total	Bio- CO2	NBio- CO2	Total CO2	CH4	N2O	CO2e
SubCategory	lb/day										lb/day					
Architectural Coating	1.4288					0.0000	0.0000		0.0000	0.0000			0.0000			0.0000
Consumer Products	4.4281					0.0000	0.0000		0.0000	0.0000			0.0000			0.0000
Landscaping	2.7000e-003	2.7000e-004	0.0293	0.0000		1.0000e-004	1.0000e-004		1.0000e-004	1.0000e-004		0.0628	0.0628	1.6000e-004		0.0669
Total	5.8596	2.7000e-004	0.0293	0.0000		1.0000e-004	1.0000e-004		1.0000e-004	1.0000e-004		0.0628	0.0628	1.6000e-004		0.0669

7.0 Water Detail

7.1 Mitigation Measures Water

Northstar #1 Project - UNMITIGATED - Imperial County, Winter

EMFAC Off-Model Adjustment Factors for Gasoline Light Duty Vehicle to Account for the SAFE Vehicle Rule Not Applied

8.0 Waste Detail

8.1 Mitigation Measures Waste

9.0 Operational Offroad

Equipment Type	Number	Hours/Day	Days/Year	Horse Power	Load Factor	Fuel Type
----------------	--------	-----------	-----------	-------------	-------------	-----------

10.0 Stationary Equipment

Fire Pumps and Emergency Generators

Equipment Type	Number	Hours/Day	Hours/Year	Horse Power	Load Factor	Fuel Type
----------------	--------	-----------	------------	-------------	-------------	-----------

Boilers

Equipment Type	Number	Heat Input/Day	Heat Input/Year	Boiler Rating	Fuel Type
----------------	--------	----------------	-----------------	---------------	-----------

User Defined Equipment

Equipment Type	Number
----------------	--------

11.0 Vegetation

Northstar #1 Project - MITIGATED - Imperial County, Winter

EMFAC Off-Model Adjustment Factors for Gasoline Light Duty Vehicle to Account for the SAFE Vehicle Rule Not Applied

Northstar #1 Project - MITIGATED

Imperial County, Winter

1.0 Project Characteristics

1.1 Land Usage

Land Uses	Size	Metric	Lot Acreage	Floor Surface Area	Population
Other Non-Asphalt Surfaces	287.00	Acre	287.00	12,501,720.00	0

1.2 Other Project Characteristics

Urbanization	Rural	Wind Speed (m/s)	3.4	Precipitation Freq (Days)	12
Climate Zone	15			Operational Year	2024
Utility Company	Imperial Irrigation District				
CO2 Intensity (lb/MWhr)	189.98	CH4 Intensity (lb/MWhr)	0.033	N2O Intensity (lb/MWhr)	0.004

1.3 User Entered Comments & Non-Default Data

Project Characteristics -

Land Use -

Construction Phase - Days of construction based on previous Z Global solar generation facility projects in Imperial County

Off-road Equipment - Equipment derived from previous Z Global solar generation facilities in Imperial County

Off-road Equipment - Ibid

Off-road Equipment - Ibid

Grading -

Construction Off-road Equipment Mitigation - ICAPCD Regulation VIII applied.

Vehicle Trips - Assume 4 heavy duty trucks trips daily

Trips and VMT - Maximum 75 workers assumed. Commute miles derived from an averaged distance between the Project Site and Brawley and the Project Site and Palm Springs [47 miles]

On-road Fugitive Dust - Mitigation Measure AQ-1

Northstar #1 Project - MITIGATED - Imperial County, Winter

EMFAC Off-Model Adjustment Factors for Gasoline Light Duty Vehicle to Account for the SAFE Vehicle Rule Not Applied

Road Dust - 1.15 miles of site access unpaved. Equates to 2.4 percent of the route

Fleet Mix - Assume 100% heavy duty truck fleet mix

Table Name	Column Name	Default Value	New Value
tblConstructionPhase	NumDays	4,650.00	85.00
tblConstructionPhase	NumDays	465.00	120.00
tblConstructionPhase	NumDays	180.00	60.00
tblConstructionPhase	PhaseEndDate	10/22/2043	3/5/2024
tblConstructionPhase	PhaseEndDate	12/25/2025	11/7/2023
tblConstructionPhase	PhaseEndDate	3/14/2024	5/23/2023
tblConstructionPhase	PhaseStartDate	12/26/2025	11/8/2023
tblConstructionPhase	PhaseStartDate	3/15/2024	5/24/2023
tblConstructionPhase	PhaseStartDate	7/7/2023	3/1/2023
tblFleetMix	HHD	0.02	1.00
tblFleetMix	LDA	0.53	0.00
tblFleetMix	LDT1	0.06	0.00
tblFleetMix	LDT2	0.18	0.00
tblFleetMix	LHD1	0.03	0.00
tblFleetMix	LHD2	6.8510e-003	0.00
tblFleetMix	MCY	0.02	0.00
tblFleetMix	MDV	0.15	0.00
tblFleetMix	MH	3.5040e-003	0.00
tblFleetMix	MHD	8.3160e-003	0.00
tblFleetMix	OBUS	9.2500e-004	0.00
tblFleetMix	SBUS	7.6600e-004	0.00
tblFleetMix	UBUS	1.2000e-004	0.00
tblOffRoadEquipment	LoadFactor	0.38	0.38
tblOffRoadEquipment	LoadFactor	0.38	0.38
tblOffRoadEquipment	LoadFactor	0.38	0.38
tblOffRoadEquipment	LoadFactor	0.42	0.42

Northstar #1 Project - MITIGATED - Imperial County, Winter

EMFAC Off-Model Adjustment Factors for Gasoline Light Duty Vehicle to Account for the SAFE Vehicle Rule Not Applied

tblOffRoadEquipment	LoadFactor	0.36	0.36
tblOffRoadEquipment	LoadFactor	0.38	0.38
tblOffRoadEquipment	LoadFactor	0.40	0.40
tblOffRoadEquipment	LoadFactor	0.50	0.50
tblOffRoadEquipment	OffRoadEquipmentType		Off-Highway Trucks
tblOffRoadEquipment	OffRoadEquipmentType		Off-Highway Trucks
tblOffRoadEquipment	OffRoadEquipmentType		Off-Highway Trucks
tblOffRoadEquipment	OffRoadEquipmentType		Pavers
tblOffRoadEquipment	OffRoadEquipmentType		Paving Equipment
tblOffRoadEquipment	OffRoadEquipmentType		Plate Compactors
tblOffRoadEquipment	OffRoadEquipmentType		Rollers
tblOffRoadEquipment	OffRoadEquipmentType		Rough Terrain Forklifts
tblOffRoadEquipment	OffRoadEquipmentType		Trenchers
tblOffRoadEquipment	OffRoadEquipmentUnitAmount	2.00	4.00
tblOffRoadEquipment	OffRoadEquipmentUnitAmount	3.00	0.00
tblOffRoadEquipment	OffRoadEquipmentUnitAmount	1.00	0.00
tblOffRoadEquipment	OffRoadEquipmentUnitAmount	1.00	3.00
tblOffRoadEquipment	OffRoadEquipmentUnitAmount	1.00	2.00
tblOffRoadEquipment	OffRoadEquipmentUnitAmount	3.00	2.00
tblOffRoadEquipment	OffRoadEquipmentUnitAmount	3.00	4.00
tblOffRoadEquipment	OffRoadEquipmentUnitAmount	2.00	4.00
tblOffRoadEquipment	OffRoadEquipmentUnitAmount	4.00	2.00
tblOnRoadDust	VendorPercentPave	50.00	100.00
tblOnRoadDust	WorkerPercentPave	50.00	100.00
tblOnRoadDust	WorkerPercentPave	50.00	100.00
tblOnRoadDust	WorkerPercentPave	50.00	100.00
tblProjectCharacteristics	UrbanizationLevel	Urban	Rural
tblRoadDust	RoadPercentPave	50	97.6
tblTripsAndVMT	VendorTripLength	11.90	47.00

Northstar #1 Project - MITIGATED - Imperial County, Winter

EMFAC Off-Model Adjustment Factors for Gasoline Light Duty Vehicle to Account for the SAFE Vehicle Rule Not Applied

tblTripsAndVMT	VendorTripNumber	2,049.00	10.00
tblTripsAndVMT	WorkerTripLength	10.20	47.00
tblTripsAndVMT	WorkerTripLength	10.20	47.00
tblTripsAndVMT	WorkerTripLength	10.20	47.00
tblTripsAndVMT	WorkerTripNumber	5,251.00	150.00
tblVehicleTrips	CC_TL	9.50	47.00
tblVehicleTrips	CC_TTP	0.00	100.00
tblVehicleTrips	CNW_TL	11.90	47.00
tblVehicleTrips	CW_TL	16.40	47.00
tblVehicleTrips	PR_TP	0.00	100.00
tblVehicleTrips	WD_TR	0.00	0.01

2.0 Emissions Summary

Northstar #1 Project - MITIGATED - Imperial County, Winter

EMFAC Off-Model Adjustment Factors for Gasoline Light Duty Vehicle to Account for the SAFE Vehicle Rule Not Applied

2.1 Overall Construction (Maximum Daily Emission)

Unmitigated Construction

	ROG	NOx	CO	SO2	Fugitive PM10	Exhaust PM10	PM10 Total	Fugitive PM2.5	Exhaust PM2.5	PM2.5 Total	Bio- CO2	NBio- CO2	Total CO2	CH4	N2O	CO2e
Year	lb/day										lb/day					
2023	7.1103	61.0704	65.6535	0.1646	18.2451	2.4862	20.7313	7.5145	2.2873	9.8018	0.0000	16,118.03 51	16,118.03 51	3.5822	0.2775	16,287.98 88
2024	6.8421	46.1363	64.2752	0.1633	5.7927	1.9571	7.7498	1.5456	1.8082	3.3538	0.0000	15,980.34 25	15,980.34 25	3.4807	0.2646	16,146.19 98
Maximum	7.1103	61.0704	65.6535	0.1646	18.2451	2.4862	20.7313	7.5145	2.2873	9.8018	0.0000	16,118.03 51	16,118.03 51	3.5822	0.2775	16,287.98 88

Mitigated Construction

	ROG	NOx	CO	SO2	Fugitive PM10	Exhaust PM10	PM10 Total	Fugitive PM2.5	Exhaust PM2.5	PM2.5 Total	Bio- CO2	NBio- CO2	Total CO2	CH4	N2O	CO2e
Year	lb/day										lb/day					
2023	7.1103	61.0704	65.6535	0.1646	8.9960	2.4862	11.4822	3.5899	2.2873	5.8772	0.0000	16,118.03 51	16,118.03 51	3.5822	0.2775	16,287.98 88
2024	6.8421	46.1363	64.2752	0.1633	5.7927	1.9571	7.7498	1.5456	1.8082	3.3538	0.0000	15,980.34 25	15,980.34 25	3.4807	0.2646	16,146.19 98
Maximum	7.1103	61.0704	65.6535	0.1646	8.9960	2.4862	11.4822	3.5899	2.2873	5.8772	0.0000	16,118.03 51	16,118.03 51	3.5822	0.2775	16,287.98 88

Northstar #1 Project - MITIGATED - Imperial County, Winter

EMFAC Off-Model Adjustment Factors for Gasoline Light Duty Vehicle to Account for the SAFE Vehicle Rule Not Applied

2.2 Overall Operational

Unmitigated Operational

	ROG	NOx	CO	SO2	Fugitive PM10	Exhaust PM10	PM10 Total	Fugitive PM2.5	Exhaust PM2.5	PM2.5 Total	Bio- CO2	NBio- CO2	Total CO2	CH4	N2O	CO2e
Category	lb/day										lb/day					
Area	5.8596	2.7000e-004	0.0293	0.0000		1.0000e-004	1.0000e-004		1.0000e-004	1.0000e-004		0.0628	0.0628	1.6000e-004		0.0669
Energy	0.0000	0.0000	0.0000	0.0000		0.0000	0.0000		0.0000	0.0000		0.0000	0.0000	0.0000	0.0000	0.0000
Mobile	0.0129	0.8587	0.1530	4.8100e-003	3.5357	0.0114	3.5471	0.3805	0.0109	0.3914		509.3617	509.3617	1.0700e-003	0.0801	533.2495
Total	5.8725	0.8589	0.1823	4.8100e-003	3.5357	0.0115	3.5472	0.3805	0.0110	0.3915		509.4245	509.4245	1.2300e-003	0.0801	533.3165

Mitigated Operational

	ROG	NOx	CO	SO2	Fugitive PM10	Exhaust PM10	PM10 Total	Fugitive PM2.5	Exhaust PM2.5	PM2.5 Total	Bio- CO2	NBio- CO2	Total CO2	CH4	N2O	CO2e
Category	lb/day										lb/day					
Area	5.8596	2.7000e-004	0.0293	0.0000		1.0000e-004	1.0000e-004		1.0000e-004	1.0000e-004		0.0628	0.0628	1.6000e-004		0.0669
Energy	0.0000	0.0000	0.0000	0.0000		0.0000	0.0000		0.0000	0.0000		0.0000	0.0000	0.0000	0.0000	0.0000
Mobile	0.0129	0.8587	0.1530	4.8100e-003	3.5357	0.0114	3.5471	0.3805	0.0109	0.3914		509.3617	509.3617	1.0700e-003	0.0801	533.2495
Total	5.8725	0.8589	0.1823	4.8100e-003	3.5357	0.0115	3.5472	0.3805	0.0110	0.3915		509.4245	509.4245	1.2300e-003	0.0801	533.3165

Northstar #1 Project - MITIGATED - Imperial County, Winter

EMFAC Off-Model Adjustment Factors for Gasoline Light Duty Vehicle to Account for the SAFE Vehicle Rule Not Applied

	ROG	NOx	CO	SO2	Fugitive PM10	Exhaust PM10	PM10 Total	Fugitive PM2.5	Exhaust PM2.5	PM2.5 Total	Bio- CO2	NBio-CO2	Total CO2	CH4	N2O	CO2e
Percent Reduction	0.00	0.00	0.00	0.00	0.00	0.00	0.00	0.00	0.00	0.00	0.00	0.00	0.00	0.00	0.00	0.00

3.0 Construction Detail

Construction Phase

Phase Number	Phase Name	Phase Type	Start Date	End Date	Num Days Week	Num Days	Phase Description
1	Site Preparation	Site Preparation	3/1/2023	5/23/2023	5	60	
2	Grading	Grading	5/24/2023	11/7/2023	5	120	
3	Building Construction	Building Construction	11/8/2023	3/5/2024	5	85	

Acres of Grading (Site Preparation Phase): 60

Acres of Grading (Grading Phase): 540

Acres of Paving: 287

Residential Indoor: 0; Residential Outdoor: 0; Non-Residential Indoor: 0; Non-Residential Outdoor: 0; Striped Parking Area: 0 (Architectural Coating – sqft)

OffRoad Equipment

Phase Name	Offroad Equipment Type	Amount	Usage Hours	Horse Power	Load Factor
Site Preparation	Off-Highway Trucks	1	8.00	402	0.38
Grading	Off-Highway Trucks	1	8.00	402	0.38
Building Construction	Cranes	1	7.00	231	0.29
Building Construction	Off-Highway Trucks	4	8.00	402	0.38
Grading	Excavators	4	8.00	158	0.38
Building Construction	Forklifts	0	8.00	89	0.20
Building Construction	Generator Sets	0	8.00	84	0.74
Grading	Graders	3	8.00	187	0.41

Northstar #1 Project - MITIGATED - Imperial County, Winter

EMFAC Off-Model Adjustment Factors for Gasoline Light Duty Vehicle to Account for the SAFE Vehicle Rule Not Applied

Building Construction	Pavers	1	8.00	130	0.42
Building Construction	Paving Equipment	2	8.00	132	0.36
Building Construction	Plate Compactors	4	8.00	8	0.43
Building Construction	Rollers	2	8.00	80	0.38
Grading	Rubber Tired Dozers	2	8.00	247	0.40
Site Preparation	Rubber Tired Dozers	2	8.00	247	0.40
Grading	Scrapers	2	8.00	367	0.48
Building Construction	Tractors/Loaders/Backhoes	4	7.00	97	0.37
Grading	Tractors/Loaders/Backhoes	4	8.00	97	0.37
Site Preparation	Tractors/Loaders/Backhoes	2	8.00	97	0.37
Building Construction	Welders	1	8.00	46	0.45
Building Construction	Rough Terrain Forklifts	4	8.00	100	0.40
Building Construction	Trenchers	2	8.00	78	0.50

Trips and VMT

Phase Name	Offroad Equipment Count	Worker Trip Number	Vendor Trip Number	Hauling Trip Number	Worker Trip Length	Vendor Trip Length	Hauling Trip Length	Worker Vehicle Class	Vendor Vehicle Class	Hauling Vehicle Class
Site Preparation	5	13.00	0.00	0.00	47.00	11.90	20.00	LD_Mix	HDT_Mix	HHDT
Grading	16	40.00	0.00	0.00	47.00	11.90	20.00	LD_Mix	HDT_Mix	HHDT
Building Construction	25	150.00	10.00	0.00	47.00	47.00	20.00	LD_Mix	HDT_Mix	HHDT

3.1 Mitigation Measures Construction

Water Exposed Area

Reduce Vehicle Speed on Unpaved Roads

Northstar #1 Project - MITIGATED - Imperial County, Winter

EMFAC Off-Model Adjustment Factors for Gasoline Light Duty Vehicle to Account for the SAFE Vehicle Rule Not Applied

3.2 Site Preparation - 2023

Unmitigated Construction On-Site

	ROG	NOx	CO	SO2	Fugitive PM10	Exhaust PM10	PM10 Total	Fugitive PM2.5	Exhaust PM2.5	PM2.5 Total	Bio- CO2	NBio- CO2	Total CO2	CH4	N2O	CO2e
Category	lb/day										lb/day					
Fugitive Dust					13.1047	0.0000	13.1047	6.7350	0.0000	6.7350			0.0000			0.0000
Off-Road	2.1784	20.9114	13.9803	0.0366		0.9231	0.9231		0.8493	0.8493		3,543.4424	3,543.4424	1.1460		3,572.0929
Total	2.1784	20.9114	13.9803	0.0366	13.1047	0.9231	14.0278	6.7350	0.8493	7.5842		3,543.4424	3,543.4424	1.1460		3,572.0929

Unmitigated Construction Off-Site

	ROG	NOx	CO	SO2	Fugitive PM10	Exhaust PM10	PM10 Total	Fugitive PM2.5	Exhaust PM2.5	PM2.5 Total	Bio- CO2	NBio- CO2	Total CO2	CH4	N2O	CO2e
Category	lb/day										lb/day					
Hauling	0.0000	0.0000	0.0000	0.0000	0.0000	0.0000	0.0000	0.0000	0.0000	0.0000		0.0000	0.0000	0.0000	0.0000	0.0000
Vendor	0.0000	0.0000	0.0000	0.0000	0.0000	0.0000	0.0000	0.0000	0.0000	0.0000		0.0000	0.0000	0.0000	0.0000	0.0000
Worker	0.1572	0.1194	1.2241	3.5800e-003	0.4643	2.0700e-003	0.4664	0.1231	1.9100e-003	0.1250		362.0667	362.0667	6.9500e-003	0.0101	365.2545
Total	0.1572	0.1194	1.2241	3.5800e-003	0.4643	2.0700e-003	0.4664	0.1231	1.9100e-003	0.1250		362.0667	362.0667	6.9500e-003	0.0101	365.2545

Northstar #1 Project - MITIGATED - Imperial County, Winter

EMFAC Off-Model Adjustment Factors for Gasoline Light Duty Vehicle to Account for the SAFE Vehicle Rule Not Applied

3.2 Site Preparation - 2023

Mitigated Construction On-Site

	ROG	NOx	CO	SO2	Fugitive PM10	Exhaust PM10	PM10 Total	Fugitive PM2.5	Exhaust PM2.5	PM2.5 Total	Bio- CO2	NBio- CO2	Total CO2	CH4	N2O	CO2e
Category	lb/day										lb/day					
Fugitive Dust					5.8971	0.0000	5.8971	3.0307	0.0000	3.0307			0.0000			0.0000
Off-Road	2.1784	20.9114	13.9803	0.0366		0.9231	0.9231		0.8493	0.8493	0.0000	3,543.442 3	3,543.442 3	1.1460		3,572.092 9
Total	2.1784	20.9114	13.9803	0.0366	5.8971	0.9231	6.8202	3.0307	0.8493	3.8800	0.0000	3,543.442 3	3,543.442 3	1.1460		3,572.092 9

Mitigated Construction Off-Site

	ROG	NOx	CO	SO2	Fugitive PM10	Exhaust PM10	PM10 Total	Fugitive PM2.5	Exhaust PM2.5	PM2.5 Total	Bio- CO2	NBio- CO2	Total CO2	CH4	N2O	CO2e
Category	lb/day										lb/day					
Hauling	0.0000	0.0000	0.0000	0.0000	0.0000	0.0000	0.0000	0.0000	0.0000	0.0000		0.0000	0.0000	0.0000	0.0000	0.0000
Vendor	0.0000	0.0000	0.0000	0.0000	0.0000	0.0000	0.0000	0.0000	0.0000	0.0000		0.0000	0.0000	0.0000	0.0000	0.0000
Worker	0.1572	0.1194	1.2241	3.5800e-003	0.4643	2.0700e-003	0.4664	0.1231	1.9100e-003	0.1250		362.0667	362.0667	6.9500e-003	0.0101	365.2545
Total	0.1572	0.1194	1.2241	3.5800e-003	0.4643	2.0700e-003	0.4664	0.1231	1.9100e-003	0.1250		362.0667	362.0667	6.9500e-003	0.0101	365.2545

Northstar #1 Project - MITIGATED - Imperial County, Winter

EMFAC Off-Model Adjustment Factors for Gasoline Light Duty Vehicle to Account for the SAFE Vehicle Rule Not Applied

3.3 Grading - 2023

Unmitigated Construction On-Site

	ROG	NOx	CO	SO2	Fugitive PM10	Exhaust PM10	PM10 Total	Fugitive PM2.5	Exhaust PM2.5	PM2.5 Total	Bio- CO2	NBio- CO2	Total CO2	CH4	N2O	CO2e
Category	lb/day										lb/day					
Fugitive Dust					16.8164	0.0000	16.8164	7.1358	0.0000	7.1358			0.0000			0.0000
Off-Road	5.9598	60.7032	48.8259	0.1137		2.4798	2.4798		2.2814	2.2814		11,009.84 10	11,009.84 10	3.5608		11,098.86 11
Total	5.9598	60.7032	48.8259	0.1137	16.8164	2.4798	19.2962	7.1358	2.2814	9.4172		11,009.84 10	11,009.84 10	3.5608		11,098.86 11

Unmitigated Construction Off-Site

	ROG	NOx	CO	SO2	Fugitive PM10	Exhaust PM10	PM10 Total	Fugitive PM2.5	Exhaust PM2.5	PM2.5 Total	Bio- CO2	NBio- CO2	Total CO2	CH4	N2O	CO2e
Category	lb/day										lb/day					
Hauling	0.0000	0.0000	0.0000	0.0000	0.0000	0.0000	0.0000	0.0000	0.0000	0.0000		0.0000	0.0000	0.0000	0.0000	0.0000
Vendor	0.0000	0.0000	0.0000	0.0000	0.0000	0.0000	0.0000	0.0000	0.0000	0.0000		0.0000	0.0000	0.0000	0.0000	0.0000
Worker	0.4836	0.3673	3.7664	0.0110	1.4287	6.3800e-003	1.4350	0.3788	5.8700e-003	0.3847		1,114.051 5	1,114.051 5	0.0214	0.0311	1,123.859 9
Total	0.4836	0.3673	3.7664	0.0110	1.4287	6.3800e-003	1.4350	0.3788	5.8700e-003	0.3847		1,114.051 5	1,114.051 5	0.0214	0.0311	1,123.859 9

Northstar #1 Project - MITIGATED - Imperial County, Winter

EMFAC Off-Model Adjustment Factors for Gasoline Light Duty Vehicle to Account for the SAFE Vehicle Rule Not Applied

3.3 Grading - 2023

Mitigated Construction On-Site

	ROG	NOx	CO	SO2	Fugitive PM10	Exhaust PM10	PM10 Total	Fugitive PM2.5	Exhaust PM2.5	PM2.5 Total	Bio- CO2	NBio- CO2	Total CO2	CH4	N2O	CO2e
Category	lb/day										lb/day					
Fugitive Dust					7.5674	0.0000	7.5674	3.2111	0.0000	3.2111			0.0000			0.0000
Off-Road	5.9598	60.7032	48.8259	0.1137		2.4798	2.4798		2.2814	2.2814	0.0000	11,009.84 10	11,009.84 10	3.5608		11,098.86 11
Total	5.9598	60.7032	48.8259	0.1137	7.5674	2.4798	10.0472	3.2111	2.2814	5.4925	0.0000	11,009.84 10	11,009.84 10	3.5608		11,098.86 11

Mitigated Construction Off-Site

	ROG	NOx	CO	SO2	Fugitive PM10	Exhaust PM10	PM10 Total	Fugitive PM2.5	Exhaust PM2.5	PM2.5 Total	Bio- CO2	NBio- CO2	Total CO2	CH4	N2O	CO2e
Category	lb/day										lb/day					
Hauling	0.0000	0.0000	0.0000	0.0000	0.0000	0.0000	0.0000	0.0000	0.0000	0.0000		0.0000	0.0000	0.0000	0.0000	0.0000
Vendor	0.0000	0.0000	0.0000	0.0000	0.0000	0.0000	0.0000	0.0000	0.0000	0.0000		0.0000	0.0000	0.0000	0.0000	0.0000
Worker	0.4836	0.3673	3.7664	0.0110	1.4287	6.3800e-003	1.4350	0.3788	5.8700e-003	0.3847		1,114.051 5	1,114.051 5	0.0214	0.0311	1,123.859 9
Total	0.4836	0.3673	3.7664	0.0110	1.4287	6.3800e-003	1.4350	0.3788	5.8700e-003	0.3847		1,114.051 5	1,114.051 5	0.0214	0.0311	1,123.859 9

Northstar #1 Project - MITIGATED - Imperial County, Winter

EMFAC Off-Model Adjustment Factors for Gasoline Light Duty Vehicle to Account for the SAFE Vehicle Rule Not Applied

3.4 Building Construction - 2023

Unmitigated Construction On-Site

	ROG	NOx	CO	SO2	Fugitive PM10	Exhaust PM10	PM10 Total	Fugitive PM2.5	Exhaust PM2.5	PM2.5 Total	Bio- CO2	NBio- CO2	Total CO2	CH4	N2O	CO2e
Category	lb/day										lb/day					
Off-Road	5.2299	45.8103	51.1124	0.1121		2.0654	2.0654		1.9077	1.9077		10,764.8165	10,764.8165	3.4068		10,849.9866
Total	5.2299	45.8103	51.1124	0.1121		2.0654	2.0654		1.9077	1.9077		10,764.8165	10,764.8165	3.4068		10,849.9866

Unmitigated Construction Off-Site

	ROG	NOx	CO	SO2	Fugitive PM10	Exhaust PM10	PM10 Total	Fugitive PM2.5	Exhaust PM2.5	PM2.5 Total	Bio- CO2	NBio- CO2	Total CO2	CH4	N2O	CO2e
Category	lb/day										lb/day					
Hauling	0.0000	0.0000	0.0000	0.0000	0.0000	0.0000	0.0000	0.0000	0.0000	0.0000		0.0000	0.0000	0.0000	0.0000	0.0000
Vendor	0.0670	1.5719	0.4173	0.0112	0.4352	0.0192	0.4544	0.1252	0.0183	0.1435		1,175.5256	1,175.5256	3.0000e-003	0.1608	1,223.5274
Worker	1.8134	1.3772	14.1239	0.0413	5.3575	0.0239	5.3814	1.4204	0.0220	1.4424		4,177.6930	4,177.6930	0.0802	0.1167	4,214.4748
Total	1.8804	2.9490	14.5411	0.0525	5.7927	0.0431	5.8357	1.5456	0.0404	1.5859		5,353.2186	5,353.2186	0.0832	0.2775	5,438.0021

Northstar #1 Project - MITIGATED - Imperial County, Winter

EMFAC Off-Model Adjustment Factors for Gasoline Light Duty Vehicle to Account for the SAFE Vehicle Rule Not Applied

3.4 Building Construction - 2023

Mitigated Construction On-Site

	ROG	NOx	CO	SO2	Fugitive PM10	Exhaust PM10	PM10 Total	Fugitive PM2.5	Exhaust PM2.5	PM2.5 Total	Bio- CO2	NBio- CO2	Total CO2	CH4	N2O	CO2e
Category	lb/day										lb/day					
Off-Road	5.2299	45.8103	51.1124	0.1121		2.0654	2.0654		1.9077	1.9077	0.0000	10,764.81 65	10,764.81 65	3.4068		10,849.98 66
Total	5.2299	45.8103	51.1124	0.1121		2.0654	2.0654		1.9077	1.9077	0.0000	10,764.81 65	10,764.81 65	3.4068		10,849.98 66

Mitigated Construction Off-Site

	ROG	NOx	CO	SO2	Fugitive PM10	Exhaust PM10	PM10 Total	Fugitive PM2.5	Exhaust PM2.5	PM2.5 Total	Bio- CO2	NBio- CO2	Total CO2	CH4	N2O	CO2e
Category	lb/day										lb/day					
Hauling	0.0000	0.0000	0.0000	0.0000	0.0000	0.0000	0.0000	0.0000	0.0000	0.0000		0.0000	0.0000	0.0000	0.0000	0.0000
Vendor	0.0670	1.5719	0.4173	0.0112	0.4352	0.0192	0.4544	0.1252	0.0183	0.1435		1,175.525 6	1,175.525 6	3.0000e- 003	0.1608	1,223.527 4
Worker	1.8134	1.3772	14.1239	0.0413	5.3575	0.0239	5.3814	1.4204	0.0220	1.4424		4,177.693 0	4,177.693 0	0.0802	0.1167	4,214.474 8
Total	1.8804	2.9490	14.5411	0.0525	5.7927	0.0431	5.8357	1.5456	0.0404	1.5859		5,353.218 6	5,353.218 6	0.0832	0.2775	5,438.002 1

Northstar #1 Project - MITIGATED - Imperial County, Winter

EMFAC Off-Model Adjustment Factors for Gasoline Light Duty Vehicle to Account for the SAFE Vehicle Rule Not Applied

3.4 Building Construction - 2024

Unmitigated Construction On-Site

	ROG	NOx	CO	SO2	Fugitive PM10	Exhaust PM10	PM10 Total	Fugitive PM2.5	Exhaust PM2.5	PM2.5 Total	Bio- CO2	NBio- CO2	Total CO2	CH4	N2O	CO2e
Category	lb/day										lb/day					
Off-Road	5.0777	43.3618	50.9456	0.1122		1.9154	1.9154		1.7691	1.7691		10,766.99 65	10,766.99 65	3.4061		10,852.14 77
Total	5.0777	43.3618	50.9456	0.1122		1.9154	1.9154		1.7691	1.7691		10,766.99 65	10,766.99 65	3.4061		10,852.14 77

Unmitigated Construction Off-Site

	ROG	NOx	CO	SO2	Fugitive PM10	Exhaust PM10	PM10 Total	Fugitive PM2.5	Exhaust PM2.5	PM2.5 Total	Bio- CO2	NBio- CO2	Total CO2	CH4	N2O	CO2e
Category	lb/day										lb/day					
Hauling	0.0000	0.0000	0.0000	0.0000	0.0000	0.0000	0.0000	0.0000	0.0000	0.0000		0.0000	0.0000	0.0000	0.0000	0.0000
Vendor	0.0634	1.5647	0.3872	0.0110	0.4352	0.0191	0.4543	0.1252	0.0183	0.1435		1,159.572 6	1,159.572 6	2.8500e- 003	0.1577	1,206.647 6
Worker	1.7010	1.2098	12.9425	0.0401	5.3575	0.0227	5.3801	1.4204	0.0209	1.4413		4,053.773 4	4,053.773 4	0.0718	0.1068	4,087.404 6
Total	1.7644	2.7745	13.3296	0.0511	5.7927	0.0418	5.8344	1.5456	0.0392	1.5847		5,213.346 0	5,213.346 0	0.0747	0.2646	5,294.052 1

Northstar #1 Project - MITIGATED - Imperial County, Winter

EMFAC Off-Model Adjustment Factors for Gasoline Light Duty Vehicle to Account for the SAFE Vehicle Rule Not Applied

3.4 Building Construction - 2024

Mitigated Construction On-Site

	ROG	NOx	CO	SO2	Fugitive PM10	Exhaust PM10	PM10 Total	Fugitive PM2.5	Exhaust PM2.5	PM2.5 Total	Bio- CO2	NBio- CO2	Total CO2	CH4	N2O	CO2e
Category	lb/day										lb/day					
Off-Road	5.0777	43.3618	50.9456	0.1122		1.9154	1.9154		1.7691	1.7691	0.0000	10,766.99 64	10,766.99 64	3.4061		10,852.14 77
Total	5.0777	43.3618	50.9456	0.1122		1.9154	1.9154		1.7691	1.7691	0.0000	10,766.99 64	10,766.99 64	3.4061		10,852.14 77

Mitigated Construction Off-Site

	ROG	NOx	CO	SO2	Fugitive PM10	Exhaust PM10	PM10 Total	Fugitive PM2.5	Exhaust PM2.5	PM2.5 Total	Bio- CO2	NBio- CO2	Total CO2	CH4	N2O	CO2e
Category	lb/day										lb/day					
Hauling	0.0000	0.0000	0.0000	0.0000	0.0000	0.0000	0.0000	0.0000	0.0000	0.0000		0.0000	0.0000	0.0000	0.0000	0.0000
Vendor	0.0634	1.5647	0.3872	0.0110	0.4352	0.0191	0.4543	0.1252	0.0183	0.1435		1,159.572 6	1,159.572 6	2.8500e- 003	0.1577	1,206.647 6
Worker	1.7010	1.2098	12.9425	0.0401	5.3575	0.0227	5.3801	1.4204	0.0209	1.4413		4,053.773 4	4,053.773 4	0.0718	0.1068	4,087.404 6
Total	1.7644	2.7745	13.3296	0.0511	5.7927	0.0418	5.8344	1.5456	0.0392	1.5847		5,213.346 0	5,213.346 0	0.0747	0.2646	5,294.052 1

Northstar #1 Project - MITIGATED - Imperial County, Winter

EMFAC Off-Model Adjustment Factors for Gasoline Light Duty Vehicle to Account for the SAFE Vehicle Rule Not Applied

4.0 Operational Detail - Mobile

4.1 Mitigation Measures Mobile

	ROG	NOx	CO	SO2	Fugitive PM10	Exhaust PM10	PM10 Total	Fugitive PM2.5	Exhaust PM2.5	PM2.5 Total	Bio- CO2	NBio- CO2	Total CO2	CH4	N2O	CO2e
Category	lb/day										lb/day					
Mitigated	0.0129	0.8587	0.1530	4.8100e-003	3.5357	0.0114	3.5471	0.3805	0.0109	0.3914		509.3617	509.3617	1.0700e-003	0.0801	533.2495
Unmitigated	0.0129	0.8587	0.1530	4.8100e-003	3.5357	0.0114	3.5471	0.3805	0.0109	0.3914		509.3617	509.3617	1.0700e-003	0.0801	533.2495

4.2 Trip Summary Information

Land Use	Average Daily Trip Rate			Unmitigated	Mitigated
	Weekday	Saturday	Sunday	Annual VMT	Annual VMT
Other Non-Asphalt Surfaces	4.02	0.00	0.00	49,100	49,100
Total	4.02	0.00	0.00	49,100	49,100

4.3 Trip Type Information

Land Use	Miles			Trip %			Trip Purpose %		
	H-W or C-W	H-S or C-C	H-O or C-NW	H-W or C-W	H-S or C-C	H-O or C-NW	Primary	Diverted	Pass-by
Other Non-Asphalt Surfaces	47.00	47.00	47.00	0.00	100.00	0.00	100	0	0

4.4 Fleet Mix

Land Use	LDA	LDT1	LDT2	MDV	LHD1	LHD2	MHD	HHD	OBUS	UBUS	MCY	SBUS	MH
Other Non-Asphalt Surfaces	0.000000	0.000000	0.000000	0.000000	0.000000	0.000000	0.000000	1.000000	0.000000	0.000000	0.000000	0.000000	0.000000

Northstar #1 Project - MITIGATED - Imperial County, Winter

EMFAC Off-Model Adjustment Factors for Gasoline Light Duty Vehicle to Account for the SAFE Vehicle Rule Not Applied

5.0 Energy Detail

Historical Energy Use: N

5.1 Mitigation Measures Energy

	ROG	NOx	CO	SO2	Fugitive PM10	Exhaust PM10	PM10 Total	Fugitive PM2.5	Exhaust PM2.5	PM2.5 Total	Bio- CO2	NBio- CO2	Total CO2	CH4	N2O	CO2e
Category	lb/day										lb/day					
NaturalGas Mitigated	0.0000	0.0000	0.0000	0.0000		0.0000	0.0000		0.0000	0.0000		0.0000	0.0000	0.0000	0.0000	0.0000
NaturalGas Unmitigated	0.0000	0.0000	0.0000	0.0000		0.0000	0.0000		0.0000	0.0000		0.0000	0.0000	0.0000	0.0000	0.0000

5.2 Energy by Land Use - NaturalGas

Unmitigated

	NaturalGas Use	ROG	NOx	CO	SO2	Fugitive PM10	Exhaust PM10	PM10 Total	Fugitive PM2.5	Exhaust PM2.5	PM2.5 Total	Bio- CO2	NBio- CO2	Total CO2	CH4	N2O	CO2e
Land Use	kBTU/yr	lb/day										lb/day					
Other Non-Asphalt Surfaces	0	0.0000	0.0000	0.0000	0.0000		0.0000	0.0000		0.0000	0.0000		0.0000	0.0000	0.0000	0.0000	0.0000
Total		0.0000	0.0000	0.0000	0.0000		0.0000	0.0000		0.0000	0.0000		0.0000	0.0000	0.0000	0.0000	0.0000

Northstar #1 Project - MITIGATED - Imperial County, Winter

EMFAC Off-Model Adjustment Factors for Gasoline Light Duty Vehicle to Account for the SAFE Vehicle Rule Not Applied

5.2 Energy by Land Use - NaturalGas

Mitigated

	NaturalGas Use	ROG	NOx	CO	SO2	Fugitive PM10	Exhaust PM10	PM10 Total	Fugitive PM2.5	Exhaust PM2.5	PM2.5 Total	Bio- CO2	NBio- CO2	Total CO2	CH4	N2O	CO2e
Land Use	kBTU/yr	lb/day										lb/day					
Other Non-Asphalt Surfaces	0	0.0000	0.0000	0.0000	0.0000		0.0000	0.0000		0.0000	0.0000		0.0000	0.0000	0.0000	0.0000	0.0000
Total		0.0000	0.0000	0.0000	0.0000		0.0000	0.0000		0.0000	0.0000		0.0000	0.0000	0.0000	0.0000	0.0000

6.0 Area Detail

6.1 Mitigation Measures Area

	ROG	NOx	CO	SO2	Fugitive PM10	Exhaust PM10	PM10 Total	Fugitive PM2.5	Exhaust PM2.5	PM2.5 Total	Bio- CO2	NBio- CO2	Total CO2	CH4	N2O	CO2e
Category	lb/day										lb/day					
Mitigated	5.8596	2.7000e-004	0.0293	0.0000		1.0000e-004	1.0000e-004		1.0000e-004	1.0000e-004		0.0628	0.0628	1.6000e-004		0.0669
Unmitigated	5.8596	2.7000e-004	0.0293	0.0000		1.0000e-004	1.0000e-004		1.0000e-004	1.0000e-004		0.0628	0.0628	1.6000e-004		0.0669

Northstar #1 Project - MITIGATED - Imperial County, Winter

EMFAC Off-Model Adjustment Factors for Gasoline Light Duty Vehicle to Account for the SAFE Vehicle Rule Not Applied

6.2 Area by SubCategory

Unmitigated

	ROG	NOx	CO	SO2	Fugitive PM10	Exhaust PM10	PM10 Total	Fugitive PM2.5	Exhaust PM2.5	PM2.5 Total	Bio- CO2	NBio- CO2	Total CO2	CH4	N2O	CO2e
SubCategory	lb/day										lb/day					
Architectural Coating	1.4288					0.0000	0.0000		0.0000	0.0000			0.0000			0.0000
Consumer Products	4.4281					0.0000	0.0000		0.0000	0.0000			0.0000			0.0000
Landscaping	2.7000e-003	2.7000e-004	0.0293	0.0000		1.0000e-004	1.0000e-004		1.0000e-004	1.0000e-004		0.0628	0.0628	1.6000e-004		0.0669
Total	5.8596	2.7000e-004	0.0293	0.0000		1.0000e-004	1.0000e-004		1.0000e-004	1.0000e-004		0.0628	0.0628	1.6000e-004		0.0669

Northstar #1 Project - MITIGATED - Imperial County, Winter

EMFAC Off-Model Adjustment Factors for Gasoline Light Duty Vehicle to Account for the SAFE Vehicle Rule Not Applied

6.2 Area by SubCategory

Mitigated

	ROG	NOx	CO	SO2	Fugitive PM10	Exhaust PM10	PM10 Total	Fugitive PM2.5	Exhaust PM2.5	PM2.5 Total	Bio- CO2	NBio- CO2	Total CO2	CH4	N2O	CO2e
SubCategory	lb/day										lb/day					
Architectural Coating	1.4288					0.0000	0.0000		0.0000	0.0000			0.0000			0.0000
Consumer Products	4.4281					0.0000	0.0000		0.0000	0.0000			0.0000			0.0000
Landscaping	2.7000e-003	2.7000e-004	0.0293	0.0000		1.0000e-004	1.0000e-004		1.0000e-004	1.0000e-004		0.0628	0.0628	1.6000e-004		0.0669
Total	5.8596	2.7000e-004	0.0293	0.0000		1.0000e-004	1.0000e-004		1.0000e-004	1.0000e-004		0.0628	0.0628	1.6000e-004		0.0669

7.0 Water Detail

7.1 Mitigation Measures Water

Northstar #1 Project - MITIGATED - Imperial County, Winter

EMFAC Off-Model Adjustment Factors for Gasoline Light Duty Vehicle to Account for the SAFE Vehicle Rule Not Applied

8.0 Waste Detail

8.1 Mitigation Measures Waste

9.0 Operational Offroad

Equipment Type	Number	Hours/Day	Days/Year	Horse Power	Load Factor	Fuel Type
----------------	--------	-----------	-----------	-------------	-------------	-----------

10.0 Stationary Equipment

Fire Pumps and Emergency Generators

Equipment Type	Number	Hours/Day	Hours/Year	Horse Power	Load Factor	Fuel Type
----------------	--------	-----------	------------	-------------	-------------	-----------

Boilers

Equipment Type	Number	Heat Input/Day	Heat Input/Year	Boiler Rating	Fuel Type
----------------	--------	----------------	-----------------	---------------	-----------

User Defined Equipment

Equipment Type	Number
----------------	--------

11.0 Vegetation

Northstar #1 Project - MITIGATED - Imperial County, Annual

EMFAC Off-Model Adjustment Factors for Gasoline Light Duty Vehicle to Account for the SAFE Vehicle Rule Not Applied

Northstar #1 Project - MITIGATED

Imperial County, Annual

1.0 Project Characteristics

1.1 Land Usage

Land Uses	Size	Metric	Lot Acreage	Floor Surface Area	Population
Other Non-Asphalt Surfaces	287.00	Acre	287.00	12,501,720.00	0

1.2 Other Project Characteristics

Urbanization	Rural	Wind Speed (m/s)	3.4	Precipitation Freq (Days)	12
Climate Zone	15	Operational Year		2024	
Utility Company	Imperial Irrigation District				
CO2 Intensity (lb/MWhr)	189.98	CH4 Intensity (lb/MWhr)	0.033	N2O Intensity (lb/MWhr)	0.004

1.3 User Entered Comments & Non-Default Data

Project Characteristics -

Land Use -

Construction Phase - Days of construction based on previous Z Global solar generation facility projects in Imperial County

Off-road Equipment - Equipment derived from previous Z Global solar generation facilities in Imperial County

Off-road Equipment - Ibid

Off-road Equipment - Ibid

Grading -

Construction Off-road Equipment Mitigation - ICAPCD Regulation VIII applied.

Vehicle Trips - Assume 4 heavy duty trucks trips daily

Trips and VMT - Maximum 75 workers assumed. Commute miles derived from an averaged distance between the Project Site and Brawley and the Project Site and Palm Springs [47 miles]

On-road Fugitive Dust - Mitigation Measure AQ-1

Northstar #1 Project - MITIGATED - Imperial County, Annual

EMFAC Off-Model Adjustment Factors for Gasoline Light Duty Vehicle to Account for the SAFE Vehicle Rule Not Applied

Road Dust - 1.15 miles of site access unpaved. Equates to 2.4 percent of the route

Fleet Mix - Assume 100% heavy duty truck fleet mix

Table Name	Column Name	Default Value	New Value
tblConstructionPhase	NumDays	4,650.00	85.00
tblConstructionPhase	NumDays	465.00	120.00
tblConstructionPhase	NumDays	180.00	60.00
tblConstructionPhase	PhaseEndDate	10/22/2043	3/5/2024
tblConstructionPhase	PhaseEndDate	12/25/2025	11/7/2023
tblConstructionPhase	PhaseEndDate	3/14/2024	5/23/2023
tblConstructionPhase	PhaseStartDate	12/26/2025	11/8/2023
tblConstructionPhase	PhaseStartDate	3/15/2024	5/24/2023
tblConstructionPhase	PhaseStartDate	7/7/2023	3/1/2023
tblFleetMix	HHD	0.02	1.00
tblFleetMix	LDA	0.53	0.00
tblFleetMix	LDT1	0.06	0.00
tblFleetMix	LDT2	0.18	0.00
tblFleetMix	LHD1	0.03	0.00
tblFleetMix	LHD2	6.8510e-003	0.00
tblFleetMix	MCY	0.02	0.00
tblFleetMix	MDV	0.15	0.00
tblFleetMix	MH	3.5040e-003	0.00
tblFleetMix	MHD	8.3160e-003	0.00
tblFleetMix	OBUS	9.2500e-004	0.00
tblFleetMix	SBUS	7.6600e-004	0.00
tblFleetMix	UBUS	1.2000e-004	0.00
tblOffRoadEquipment	LoadFactor	0.38	0.38
tblOffRoadEquipment	LoadFactor	0.38	0.38
tblOffRoadEquipment	LoadFactor	0.38	0.38
tblOffRoadEquipment	LoadFactor	0.42	0.42

Northstar #1 Project - MITIGATED - Imperial County, Annual

EMFAC Off-Model Adjustment Factors for Gasoline Light Duty Vehicle to Account for the SAFE Vehicle Rule Not Applied

tblOffRoadEquipment	LoadFactor	0.36	0.36
tblOffRoadEquipment	LoadFactor	0.38	0.38
tblOffRoadEquipment	LoadFactor	0.40	0.40
tblOffRoadEquipment	LoadFactor	0.50	0.50
tblOffRoadEquipment	OffRoadEquipmentType		Off-Highway Trucks
tblOffRoadEquipment	OffRoadEquipmentType		Off-Highway Trucks
tblOffRoadEquipment	OffRoadEquipmentType		Off-Highway Trucks
tblOffRoadEquipment	OffRoadEquipmentType		Pavers
tblOffRoadEquipment	OffRoadEquipmentType		Paving Equipment
tblOffRoadEquipment	OffRoadEquipmentType		Plate Compactors
tblOffRoadEquipment	OffRoadEquipmentType		Rollers
tblOffRoadEquipment	OffRoadEquipmentType		Rough Terrain Forklifts
tblOffRoadEquipment	OffRoadEquipmentType		Trenchers
tblOffRoadEquipment	OffRoadEquipmentUnitAmount	2.00	4.00
tblOffRoadEquipment	OffRoadEquipmentUnitAmount	3.00	0.00
tblOffRoadEquipment	OffRoadEquipmentUnitAmount	1.00	0.00
tblOffRoadEquipment	OffRoadEquipmentUnitAmount	1.00	3.00
tblOffRoadEquipment	OffRoadEquipmentUnitAmount	1.00	2.00
tblOffRoadEquipment	OffRoadEquipmentUnitAmount	3.00	2.00
tblOffRoadEquipment	OffRoadEquipmentUnitAmount	3.00	4.00
tblOffRoadEquipment	OffRoadEquipmentUnitAmount	2.00	4.00
tblOffRoadEquipment	OffRoadEquipmentUnitAmount	4.00	2.00
tblOnRoadDust	VendorPercentPave	50.00	100.00
tblOnRoadDust	WorkerPercentPave	50.00	100.00
tblOnRoadDust	WorkerPercentPave	50.00	100.00
tblOnRoadDust	WorkerPercentPave	50.00	100.00
tblProjectCharacteristics	UrbanizationLevel	Urban	Rural
tblRoadDust	RoadPercentPave	50	97.6
tblTripsAndVMT	VendorTripLength	11.90	47.00

Northstar #1 Project - MITIGATED - Imperial County, Annual

EMFAC Off-Model Adjustment Factors for Gasoline Light Duty Vehicle to Account for the SAFE Vehicle Rule Not Applied

tblTripsAndVMT	VendorTripNumber	2,049.00	10.00
tblTripsAndVMT	WorkerTripLength	10.20	47.00
tblTripsAndVMT	WorkerTripLength	10.20	47.00
tblTripsAndVMT	WorkerTripLength	10.20	47.00
tblTripsAndVMT	WorkerTripNumber	5,251.00	150.00
tblVehicleTrips	CC_TL	9.50	47.00
tblVehicleTrips	CC_TTP	0.00	100.00
tblVehicleTrips	CNW_TL	11.90	47.00
tblVehicleTrips	CW_TL	16.40	47.00
tblVehicleTrips	PR_TP	0.00	100.00
tblVehicleTrips	WD_TR	0.00	0.01

2.0 Emissions Summary

Northstar #1 Project - MITIGATED - Imperial County, Annual

EMFAC Off-Model Adjustment Factors for Gasoline Light Duty Vehicle to Account for the SAFE Vehicle Rule Not Applied

2.1 Overall Construction

Unmitigated Construction

	ROG	NOx	CO	SO2	Fugitive PM10	Exhaust PM10	PM10 Total	Fugitive PM2.5	Exhaust PM2.5	PM2.5 Total	Bio- CO2	NBio- CO2	Total CO2	CH4	N2O	CO2e
Year	tons/yr										MT/yr					
2023	0.5902	5.2204	4.9541	0.0119	1.6104	0.2170	1.8273	0.6856	0.1998	0.8854	0.0000	1,054.5283	1,054.5283	0.2867	6.7300e-003	1,063.7018
2024	0.1598	1.0833	1.5651	3.9100e-003	0.1352	0.0460	0.1812	0.0361	0.0425	0.0786	0.0000	347.0307	347.0307	0.0743	5.6300e-003	350.5654
Maximum	0.5902	5.2204	4.9541	0.0119	1.6104	0.2170	1.8273	0.6856	0.1998	0.8854	0.0000	1,054.5283	1,054.5283	0.2867	6.7300e-003	1,063.7018

Mitigated Construction

	ROG	NOx	CO	SO2	Fugitive PM10	Exhaust PM10	PM10 Total	Fugitive PM2.5	Exhaust PM2.5	PM2.5 Total	Bio- CO2	NBio- CO2	Total CO2	CH4	N2O	CO2e
Year	tons/yr										MT/yr					
2023	0.5902	5.2204	4.9541	0.0119	0.8392	0.2170	1.0562	0.3390	0.1998	0.5388	0.0000	1,054.5272	1,054.5272	0.2867	6.7300e-003	1,063.7008
2024	0.1598	1.0833	1.5651	3.9100e-003	0.1352	0.0460	0.1812	0.0361	0.0425	0.0786	0.0000	347.0304	347.0304	0.0743	5.6300e-003	350.5651
Maximum	0.5902	5.2204	4.9541	0.0119	0.8392	0.2170	1.0562	0.3390	0.1998	0.5388	0.0000	1,054.5272	1,054.5272	0.2867	6.7300e-003	1,063.7008

Northstar #1 Project - MITIGATED - Imperial County, Annual

EMFAC Off-Model Adjustment Factors for Gasoline Light Duty Vehicle to Account for the SAFE Vehicle Rule Not Applied

	ROG	NOx	CO	SO2	Fugitive PM10	Exhaust PM10	PM10 Total	Fugitive PM2.5	Exhaust PM2.5	PM2.5 Total	Bio- CO2	NBio-CO2	Total CO2	CH4	N2O	CO2e
Percent Reduction	0.00	0.00	0.00	0.00	44.18	0.00	38.40	48.03	0.00	35.96	0.00	0.00	0.00	0.00	0.00	0.00

Quarter	Start Date	End Date	Maximum Unmitigated ROG + NOX (tons/quarter)	Maximum Mitigated ROG + NOX (tons/quarter)
4	2-13-2023	5-12-2023	0.6093	0.6093
5	5-13-2023	8-12-2023	2.0457	2.0457
6	8-13-2023	11-12-2023	2.1980	2.1980
7	11-13-2023	2-12-2024	1.7913	1.7913
8	2-13-2024	5-12-2024	0.4163	0.4163
		Highest	2.1980	2.1980

2.2 Overall Operational

Unmitigated Operational

	ROG	NOx	CO	SO2	Fugitive PM10	Exhaust PM10	PM10 Total	Fugitive PM2.5	Exhaust PM2.5	PM2.5 Total	Bio- CO2	NBio- CO2	Total CO2	CH4	N2O	CO2e
Category	tons/yr										MT/yr					
Area	1.0691	2.0000e-005	2.6300e-003	0.0000		1.0000e-005	1.0000e-005		1.0000e-005	1.0000e-005	0.0000	5.1300e-003	5.1300e-003	1.0000e-005	0.0000	5.4600e-003
Energy	0.0000	0.0000	0.0000	0.0000		0.0000	0.0000		0.0000	0.0000	0.0000	0.0000	0.0000	0.0000	0.0000	0.0000
Mobile	1.7400e-003	0.1099	0.0197	6.2000e-004	0.4595	1.4800e-003	0.4610	0.0494	1.4100e-003	0.0509	0.0000	59.9693	59.9693	1.3000e-004	9.4300e-003	62.7818
Waste						0.0000	0.0000		0.0000	0.0000	0.0000	0.0000	0.0000	0.0000	0.0000	0.0000
Water						0.0000	0.0000		0.0000	0.0000	0.0000	0.0000	0.0000	0.0000	0.0000	0.0000
Total	1.0709	0.1099	0.0223	6.2000e-004	0.4595	1.4900e-003	0.4610	0.0494	1.4200e-003	0.0509	0.0000	59.9745	59.9745	1.4000e-004	9.4300e-003	62.7873

Northstar #1 Project - MITIGATED - Imperial County, Annual

EMFAC Off-Model Adjustment Factors for Gasoline Light Duty Vehicle to Account for the SAFE Vehicle Rule Not Applied

2.2 Overall Operational

Mitigated Operational

	ROG	NOx	CO	SO2	Fugitive PM10	Exhaust PM10	PM10 Total	Fugitive PM2.5	Exhaust PM2.5	PM2.5 Total	Bio- CO2	NBio- CO2	Total CO2	CH4	N2O	CO2e
Category	tons/yr										MT/yr					
Area	1.0691	2.0000e-005	2.6300e-003	0.0000		1.0000e-005	1.0000e-005		1.0000e-005	1.0000e-005	0.0000	5.1300e-003	5.1300e-003	1.0000e-005	0.0000	5.4600e-003
Energy	0.0000	0.0000	0.0000	0.0000		0.0000	0.0000		0.0000	0.0000	0.0000	0.0000	0.0000	0.0000	0.0000	0.0000
Mobile	1.7400e-003	0.1099	0.0197	6.2000e-004	0.4595	1.4800e-003	0.4610	0.0494	1.4100e-003	0.0509	0.0000	59.9693	59.9693	1.3000e-004	9.4300e-003	62.7818
Waste						0.0000	0.0000		0.0000	0.0000	0.0000	0.0000	0.0000	0.0000	0.0000	0.0000
Water						0.0000	0.0000		0.0000	0.0000	0.0000	0.0000	0.0000	0.0000	0.0000	0.0000
Total	1.0709	0.1099	0.0223	6.2000e-004	0.4595	1.4900e-003	0.4610	0.0494	1.4200e-003	0.0509	0.0000	59.9745	59.9745	1.4000e-004	9.4300e-003	62.7873

	ROG	NOx	CO	SO2	Fugitive PM10	Exhaust PM10	PM10 Total	Fugitive PM2.5	Exhaust PM2.5	PM2.5 Total	Bio- CO2	NBio- CO2	Total CO2	CH4	N2O	CO2e
Percent Reduction	0.00	0.00	0.00	0.00	0.00	0.00	0.00	0.00	0.00	0.00	0.00	0.00	0.00	0.00	0.00	0.00

3.0 Construction Detail

Construction Phase

Phase Number	Phase Name	Phase Type	Start Date	End Date	Num Days Week	Num Days	Phase Description
1	Site Preparation	Site Preparation	3/1/2023	5/23/2023	5	60	
2	Grading	Grading	5/24/2023	11/7/2023	5	120	
3	Building Construction	Building Construction	11/8/2023	3/5/2024	5	85	

Northstar #1 Project - MITIGATED - Imperial County, Annual

EMFAC Off-Model Adjustment Factors for Gasoline Light Duty Vehicle to Account for the SAFE Vehicle Rule Not Applied

Acres of Grading (Site Preparation Phase): 60

Acres of Grading (Grading Phase): 540

Acres of Paving: 287

Residential Indoor: 0; Residential Outdoor: 0; Non-Residential Indoor: 0; Non-Residential Outdoor: 0; Striped Parking Area: 0 (Architectural Coating – sqft)

OffRoad Equipment

Phase Name	Offroad Equipment Type	Amount	Usage Hours	Horse Power	Load Factor
Site Preparation	Off-Highway Trucks	1	8.00	402	0.38
Grading	Off-Highway Trucks	1	8.00	402	0.38
Building Construction	Cranes	1	7.00	231	0.29
Building Construction	Off-Highway Trucks	4	8.00	402	0.38
Grading	Excavators	4	8.00	158	0.38
Building Construction	Forklifts	0	8.00	89	0.20
Building Construction	Generator Sets	0	8.00	84	0.74
Grading	Graders	3	8.00	187	0.41
Building Construction	Pavers	1	8.00	130	0.42
Building Construction	Paving Equipment	2	8.00	132	0.36
Building Construction	Plate Compactors	4	8.00	8	0.43
Building Construction	Rollers	2	8.00	80	0.38
Grading	Rubber Tired Dozers	2	8.00	247	0.40
Site Preparation	Rubber Tired Dozers	2	8.00	247	0.40
Grading	Scrapers	2	8.00	367	0.48
Building Construction	Tractors/Loaders/Backhoes	4	7.00	97	0.37
Grading	Tractors/Loaders/Backhoes	4	8.00	97	0.37
Site Preparation	Tractors/Loaders/Backhoes	2	8.00	97	0.37
Building Construction	Welders	1	8.00	46	0.45
Building Construction	Rough Terrain Forklifts	4	8.00	100	0.40

Northstar #1 Project - MITIGATED - Imperial County, Annual

EMFAC Off-Model Adjustment Factors for Gasoline Light Duty Vehicle to Account for the SAFE Vehicle Rule Not Applied

Building Construction	Trenchers	2	8.00	78	0.50
-----------------------	-----------	---	------	----	------

Trips and VMT

Phase Name	Offroad Equipment Count	Worker Trip Number	Vendor Trip Number	Hauling Trip Number	Worker Trip Length	Vendor Trip Length	Hauling Trip Length	Worker Vehicle Class	Vendor Vehicle Class	Hauling Vehicle Class
Site Preparation	5	13.00	0.00	0.00	47.00	11.90	20.00	LD_Mix	HDT_Mix	HHDT
Grading	16	40.00	0.00	0.00	47.00	11.90	20.00	LD_Mix	HDT_Mix	HHDT
Building Construction	25	150.00	10.00	0.00	47.00	47.00	20.00	LD_Mix	HDT_Mix	HHDT

3.1 Mitigation Measures Construction

Water Exposed Area

Reduce Vehicle Speed on Unpaved Roads

3.2 Site Preparation - 2023

Unmitigated Construction On-Site

	ROG	NOx	CO	SO2	Fugitive PM10	Exhaust PM10	PM10 Total	Fugitive PM2.5	Exhaust PM2.5	PM2.5 Total	Bio- CO2	NBio- CO2	Total CO2	CH4	N2O	CO2e
Category	tons/yr										MT/yr					
Fugitive Dust					0.3931	0.0000	0.3931	0.2021	0.0000	0.2021	0.0000	0.0000	0.0000	0.0000	0.0000	0.0000
Off-Road	0.0654	0.6273	0.4194	1.1000e-003		0.0277	0.0277		0.0255	0.0255	0.0000	96.4367	96.4367	0.0312	0.0000	97.2164
Total	0.0654	0.6273	0.4194	1.1000e-003	0.3931	0.0277	0.4208	0.2021	0.0255	0.2275	0.0000	96.4367	96.4367	0.0312	0.0000	97.2164

Northstar #1 Project - MITIGATED - Imperial County, Annual

EMFAC Off-Model Adjustment Factors for Gasoline Light Duty Vehicle to Account for the SAFE Vehicle Rule Not Applied

3.2 Site Preparation - 2023

Unmitigated Construction Off-Site

	ROG	NOx	CO	SO2	Fugitive PM10	Exhaust PM10	PM10 Total	Fugitive PM2.5	Exhaust PM2.5	PM2.5 Total	Bio- CO2	NBio- CO2	Total CO2	CH4	N2O	CO2e
Category	tons/yr										MT/yr					
Hauling	0.0000	0.0000	0.0000	0.0000	0.0000	0.0000	0.0000	0.0000	0.0000	0.0000	0.0000	0.0000	0.0000	0.0000	0.0000	0.0000
Vendor	0.0000	0.0000	0.0000	0.0000	0.0000	0.0000	0.0000	0.0000	0.0000	0.0000	0.0000	0.0000	0.0000	0.0000	0.0000	0.0000
Worker	4.6100e-003	3.5300e-003	0.0433	1.2000e-004	0.0138	6.0000e-005	0.0139	3.6700e-003	6.0000e-005	3.7300e-003	0.0000	10.5804	10.5804	2.0000e-004	2.7000e-004	10.6671
Total	4.6100e-003	3.5300e-003	0.0433	1.2000e-004	0.0138	6.0000e-005	0.0139	3.6700e-003	6.0000e-005	3.7300e-003	0.0000	10.5804	10.5804	2.0000e-004	2.7000e-004	10.6671

Mitigated Construction On-Site

	ROG	NOx	CO	SO2	Fugitive PM10	Exhaust PM10	PM10 Total	Fugitive PM2.5	Exhaust PM2.5	PM2.5 Total	Bio- CO2	NBio- CO2	Total CO2	CH4	N2O	CO2e
Category	tons/yr										MT/yr					
Fugitive Dust					0.1769	0.0000	0.1769	0.0909	0.0000	0.0909	0.0000	0.0000	0.0000	0.0000	0.0000	0.0000
Off-Road	0.0654	0.6273	0.4194	1.1000e-003		0.0277	0.0277		0.0255	0.0255	0.0000	96.4366	96.4366	0.0312	0.0000	97.2163
Total	0.0654	0.6273	0.4194	1.1000e-003	0.1769	0.0277	0.2046	0.0909	0.0255	0.1164	0.0000	96.4366	96.4366	0.0312	0.0000	97.2163

Northstar #1 Project - MITIGATED - Imperial County, Annual

EMFAC Off-Model Adjustment Factors for Gasoline Light Duty Vehicle to Account for the SAFE Vehicle Rule Not Applied

3.2 Site Preparation - 2023

Mitigated Construction Off-Site

	ROG	NOx	CO	SO2	Fugitive PM10	Exhaust PM10	PM10 Total	Fugitive PM2.5	Exhaust PM2.5	PM2.5 Total	Bio- CO2	NBio- CO2	Total CO2	CH4	N2O	CO2e
Category	tons/yr										MT/yr					
Hauling	0.0000	0.0000	0.0000	0.0000	0.0000	0.0000	0.0000	0.0000	0.0000	0.0000	0.0000	0.0000	0.0000	0.0000	0.0000	0.0000
Vendor	0.0000	0.0000	0.0000	0.0000	0.0000	0.0000	0.0000	0.0000	0.0000	0.0000	0.0000	0.0000	0.0000	0.0000	0.0000	0.0000
Worker	4.6100e-003	3.5300e-003	0.0433	1.2000e-004	0.0138	6.0000e-005	0.0139	3.6700e-003	6.0000e-005	3.7300e-003	0.0000	10.5804	10.5804	2.0000e-004	2.7000e-004	10.6671
Total	4.6100e-003	3.5300e-003	0.0433	1.2000e-004	0.0138	6.0000e-005	0.0139	3.6700e-003	6.0000e-005	3.7300e-003	0.0000	10.5804	10.5804	2.0000e-004	2.7000e-004	10.6671

3.3 Grading - 2023

Unmitigated Construction On-Site

	ROG	NOx	CO	SO2	Fugitive PM10	Exhaust PM10	PM10 Total	Fugitive PM2.5	Exhaust PM2.5	PM2.5 Total	Bio- CO2	NBio- CO2	Total CO2	CH4	N2O	CO2e
Category	tons/yr										MT/yr					
Fugitive Dust					1.0090	0.0000	1.0090	0.4281	0.0000	0.4281	0.0000	0.0000	0.0000	0.0000	0.0000	0.0000
Off-Road	0.3576	3.6422	2.9296	6.8200e-003		0.1488	0.1488		0.1369	0.1369	0.0000	599.2776	599.2776	0.1938	0.0000	604.1231
Total	0.3576	3.6422	2.9296	6.8200e-003	1.0090	0.1488	1.1578	0.4281	0.1369	0.5650	0.0000	599.2776	599.2776	0.1938	0.0000	604.1231

Northstar #1 Project - MITIGATED - Imperial County, Annual

EMFAC Off-Model Adjustment Factors for Gasoline Light Duty Vehicle to Account for the SAFE Vehicle Rule Not Applied

3.3 Grading - 2023

Unmitigated Construction Off-Site

	ROG	NOx	CO	SO2	Fugitive PM10	Exhaust PM10	PM10 Total	Fugitive PM2.5	Exhaust PM2.5	PM2.5 Total	Bio- CO2	NBio- CO2	Total CO2	CH4	N2O	CO2e
Category	tons/yr										MT/yr					
Hauling	0.0000	0.0000	0.0000	0.0000	0.0000	0.0000	0.0000	0.0000	0.0000	0.0000	0.0000	0.0000	0.0000	0.0000	0.0000	0.0000
Vendor	0.0000	0.0000	0.0000	0.0000	0.0000	0.0000	0.0000	0.0000	0.0000	0.0000	0.0000	0.0000	0.0000	0.0000	0.0000	0.0000
Worker	0.0284	0.0217	0.2664	7.1000e-004	0.0851	3.8000e-004	0.0855	0.0226	3.5000e-004	0.0229	0.0000	65.1104	65.1104	1.2300e-003	1.6900e-003	65.6439
Total	0.0284	0.0217	0.2664	7.1000e-004	0.0851	3.8000e-004	0.0855	0.0226	3.5000e-004	0.0229	0.0000	65.1104	65.1104	1.2300e-003	1.6900e-003	65.6439

Mitigated Construction On-Site

	ROG	NOx	CO	SO2	Fugitive PM10	Exhaust PM10	PM10 Total	Fugitive PM2.5	Exhaust PM2.5	PM2.5 Total	Bio- CO2	NBio- CO2	Total CO2	CH4	N2O	CO2e
Category	tons/yr										MT/yr					
Fugitive Dust					0.4540	0.0000	0.4540	0.1927	0.0000	0.1927	0.0000	0.0000	0.0000	0.0000	0.0000	0.0000
Off-Road	0.3576	3.6422	2.9296	6.8200e-003		0.1488	0.1488		0.1369	0.1369	0.0000	599.2769	599.2769	0.1938	0.0000	604.1223
Total	0.3576	3.6422	2.9296	6.8200e-003	0.4540	0.1488	0.6028	0.1927	0.1369	0.3296	0.0000	599.2769	599.2769	0.1938	0.0000	604.1223

Northstar #1 Project - MITIGATED - Imperial County, Annual

EMFAC Off-Model Adjustment Factors for Gasoline Light Duty Vehicle to Account for the SAFE Vehicle Rule Not Applied

3.3 Grading - 2023

Mitigated Construction Off-Site

	ROG	NOx	CO	SO2	Fugitive PM10	Exhaust PM10	PM10 Total	Fugitive PM2.5	Exhaust PM2.5	PM2.5 Total	Bio- CO2	NBio- CO2	Total CO2	CH4	N2O	CO2e
Category	tons/yr										MT/yr					
Hauling	0.0000	0.0000	0.0000	0.0000	0.0000	0.0000	0.0000	0.0000	0.0000	0.0000	0.0000	0.0000	0.0000	0.0000	0.0000	0.0000
Vendor	0.0000	0.0000	0.0000	0.0000	0.0000	0.0000	0.0000	0.0000	0.0000	0.0000	0.0000	0.0000	0.0000	0.0000	0.0000	0.0000
Worker	0.0284	0.0217	0.2664	7.1000e-004	0.0851	3.8000e-004	0.0855	0.0226	3.5000e-004	0.0229	0.0000	65.1104	65.1104	1.2300e-003	1.6900e-003	65.6439
Total	0.0284	0.0217	0.2664	7.1000e-004	0.0851	3.8000e-004	0.0855	0.0226	3.5000e-004	0.0229	0.0000	65.1104	65.1104	1.2300e-003	1.6900e-003	65.6439

3.4 Building Construction - 2023

Unmitigated Construction On-Site

	ROG	NOx	CO	SO2	Fugitive PM10	Exhaust PM10	PM10 Total	Fugitive PM2.5	Exhaust PM2.5	PM2.5 Total	Bio- CO2	NBio- CO2	Total CO2	CH4	N2O	CO2e
Category	tons/yr										MT/yr					
Off-Road	0.0994	0.8704	0.9711	2.1300e-003		0.0392	0.0392		0.0363	0.0363	0.0000	185.5479	185.5479	0.0587	0.0000	187.0159
Total	0.0994	0.8704	0.9711	2.1300e-003		0.0392	0.0392		0.0363	0.0363	0.0000	185.5479	185.5479	0.0587	0.0000	187.0159

Northstar #1 Project - MITIGATED - Imperial County, Annual

EMFAC Off-Model Adjustment Factors for Gasoline Light Duty Vehicle to Account for the SAFE Vehicle Rule Not Applied

3.4 Building Construction - 2023

Unmitigated Construction Off-Site

	ROG	NOx	CO	SO2	Fugitive PM10	Exhaust PM10	PM10 Total	Fugitive PM2.5	Exhaust PM2.5	PM2.5 Total	Bio- CO2	NBio- CO2	Total CO2	CH4	N2O	CO2e
Category	tons/yr										MT/yr					
Hauling	0.0000	0.0000	0.0000	0.0000	0.0000	0.0000	0.0000	0.0000	0.0000	0.0000	0.0000	0.0000	0.0000	0.0000	0.0000	0.0000
Vendor	1.2500e-003	0.0294	7.9400e-003	2.1000e-004	8.2200e-003	3.6000e-004	8.5800e-003	2.3700e-003	3.5000e-004	2.7100e-003	0.0000	20.2566	20.2566	5.0000e-005	2.7700e-003	21.0832
Worker	0.0337	0.0258	0.3163	8.4000e-004	0.1011	4.5000e-004	0.1015	0.0268	4.2000e-004	0.0272	0.0000	77.3186	77.3186	1.4600e-003	2.0000e-003	77.9521
Total	0.0349	0.0553	0.3243	1.0500e-003	0.1093	8.1000e-004	0.1101	0.0292	7.7000e-004	0.0299	0.0000	97.5753	97.5753	1.5100e-003	4.7700e-003	99.0354

Mitigated Construction On-Site

	ROG	NOx	CO	SO2	Fugitive PM10	Exhaust PM10	PM10 Total	Fugitive PM2.5	Exhaust PM2.5	PM2.5 Total	Bio- CO2	NBio- CO2	Total CO2	CH4	N2O	CO2e
Category	tons/yr										MT/yr					
Off-Road	0.0994	0.8704	0.9711	2.1300e-003		0.0392	0.0392		0.0363	0.0363	0.0000	185.5477	185.5477	0.0587	0.0000	187.0157
Total	0.0994	0.8704	0.9711	2.1300e-003		0.0392	0.0392		0.0363	0.0363	0.0000	185.5477	185.5477	0.0587	0.0000	187.0157

Northstar #1 Project - MITIGATED - Imperial County, Annual

EMFAC Off-Model Adjustment Factors for Gasoline Light Duty Vehicle to Account for the SAFE Vehicle Rule Not Applied

3.4 Building Construction - 2023

Mitigated Construction Off-Site

	ROG	NOx	CO	SO2	Fugitive PM10	Exhaust PM10	PM10 Total	Fugitive PM2.5	Exhaust PM2.5	PM2.5 Total	Bio- CO2	NBio- CO2	Total CO2	CH4	N2O	CO2e
Category	tons/yr										MT/yr					
Hauling	0.0000	0.0000	0.0000	0.0000	0.0000	0.0000	0.0000	0.0000	0.0000	0.0000	0.0000	0.0000	0.0000	0.0000	0.0000	0.0000
Vendor	1.2500e-003	0.0294	7.9400e-003	2.1000e-004	8.2200e-003	3.6000e-004	8.5800e-003	2.3700e-003	3.5000e-004	2.7100e-003	0.0000	20.2566	20.2566	5.0000e-005	2.7700e-003	21.0832
Worker	0.0337	0.0258	0.3163	8.4000e-004	0.1011	4.5000e-004	0.1015	0.0268	4.2000e-004	0.0272	0.0000	77.3186	77.3186	1.4600e-003	2.0000e-003	77.9521
Total	0.0349	0.0553	0.3243	1.0500e-003	0.1093	8.1000e-004	0.1101	0.0292	7.7000e-004	0.0299	0.0000	97.5753	97.5753	1.5100e-003	4.7700e-003	99.0354

3.4 Building Construction - 2024

Unmitigated Construction On-Site

	ROG	NOx	CO	SO2	Fugitive PM10	Exhaust PM10	PM10 Total	Fugitive PM2.5	Exhaust PM2.5	PM2.5 Total	Bio- CO2	NBio- CO2	Total CO2	CH4	N2O	CO2e
Category	tons/yr										MT/yr					
Off-Road	0.1193	1.0190	1.1972	2.6400e-003		0.0450	0.0450		0.0416	0.0416	0.0000	229.5399	229.5399	0.0726	0.0000	231.3552
Total	0.1193	1.0190	1.1972	2.6400e-003		0.0450	0.0450		0.0416	0.0416	0.0000	229.5399	229.5399	0.0726	0.0000	231.3552

Northstar #1 Project - MITIGATED - Imperial County, Annual

EMFAC Off-Model Adjustment Factors for Gasoline Light Duty Vehicle to Account for the SAFE Vehicle Rule Not Applied

3.4 Building Construction - 2024

Unmitigated Construction Off-Site

	ROG	NOx	CO	SO2	Fugitive PM10	Exhaust PM10	PM10 Total	Fugitive PM2.5	Exhaust PM2.5	PM2.5 Total	Bio- CO2	NBio- CO2	Total CO2	CH4	N2O	CO2e
Category	tons/yr										MT/yr					
Hauling	0.0000	0.0000	0.0000	0.0000	0.0000	0.0000	0.0000	0.0000	0.0000	0.0000	0.0000	0.0000	0.0000	0.0000	0.0000	0.0000
Vendor	1.4600e-003	0.0363	9.0900e-003	2.6000e-004	0.0102	4.5000e-004	0.0106	2.9300e-003	4.3000e-004	3.3600e-003	0.0000	24.7141	24.7141	6.0000e-005	3.3600e-003	25.7168
Worker	0.0390	0.0281	0.3588	1.0100e-003	0.1250	5.3000e-004	0.1255	0.0332	4.9000e-004	0.0337	0.0000	92.7767	92.7767	1.6200e-003	2.2700e-003	93.4934
Total	0.0404	0.0643	0.3679	1.2700e-003	0.1352	9.8000e-004	0.1362	0.0361	9.2000e-004	0.0370	0.0000	117.4908	117.4908	1.6800e-003	5.6300e-003	119.2102

Mitigated Construction On-Site

	ROG	NOx	CO	SO2	Fugitive PM10	Exhaust PM10	PM10 Total	Fugitive PM2.5	Exhaust PM2.5	PM2.5 Total	Bio- CO2	NBio- CO2	Total CO2	CH4	N2O	CO2e
Category	tons/yr										MT/yr					
Off-Road	0.1193	1.0190	1.1972	2.6400e-003		0.0450	0.0450		0.0416	0.0416	0.0000	229.5396	229.5396	0.0726	0.0000	231.3549
Total	0.1193	1.0190	1.1972	2.6400e-003		0.0450	0.0450		0.0416	0.0416	0.0000	229.5396	229.5396	0.0726	0.0000	231.3549

Northstar #1 Project - MITIGATED - Imperial County, Annual

EMFAC Off-Model Adjustment Factors for Gasoline Light Duty Vehicle to Account for the SAFE Vehicle Rule Not Applied

3.4 Building Construction - 2024

Mitigated Construction Off-Site

	ROG	NOx	CO	SO2	Fugitive PM10	Exhaust PM10	PM10 Total	Fugitive PM2.5	Exhaust PM2.5	PM2.5 Total	Bio- CO2	NBio- CO2	Total CO2	CH4	N2O	CO2e
Category	tons/yr										MT/yr					
Hauling	0.0000	0.0000	0.0000	0.0000	0.0000	0.0000	0.0000	0.0000	0.0000	0.0000	0.0000	0.0000	0.0000	0.0000	0.0000	0.0000
Vendor	1.4600e-003	0.0363	9.0900e-003	2.6000e-004	0.0102	4.5000e-004	0.0106	2.9300e-003	4.3000e-004	3.3600e-003	0.0000	24.7141	24.7141	6.0000e-005	3.3600e-003	25.7168
Worker	0.0390	0.0281	0.3588	1.0100e-003	0.1250	5.3000e-004	0.1255	0.0332	4.9000e-004	0.0337	0.0000	92.7767	92.7767	1.6200e-003	2.2700e-003	93.4934
Total	0.0404	0.0643	0.3679	1.2700e-003	0.1352	9.8000e-004	0.1362	0.0361	9.2000e-004	0.0370	0.0000	117.4908	117.4908	1.6800e-003	5.6300e-003	119.2102

Northstar #1 Project - MITIGATED - Imperial County, Annual

EMFAC Off-Model Adjustment Factors for Gasoline Light Duty Vehicle to Account for the SAFE Vehicle Rule Not Applied

4.0 Operational Detail - Mobile

4.1 Mitigation Measures Mobile

	ROG	NOx	CO	SO2	Fugitive PM10	Exhaust PM10	PM10 Total	Fugitive PM2.5	Exhaust PM2.5	PM2.5 Total	Bio- CO2	NBio- CO2	Total CO2	CH4	N2O	CO2e
Category	tons/yr										MT/yr					
Mitigated	1.7400e-003	0.1099	0.0197	6.2000e-004	0.4595	1.4800e-003	0.4610	0.0494	1.4100e-003	0.0509	0.0000	59.9693	59.9693	1.3000e-004	9.4300e-003	62.7818
Unmitigated	1.7400e-003	0.1099	0.0197	6.2000e-004	0.4595	1.4800e-003	0.4610	0.0494	1.4100e-003	0.0509	0.0000	59.9693	59.9693	1.3000e-004	9.4300e-003	62.7818

4.2 Trip Summary Information

Land Use	Average Daily Trip Rate			Unmitigated	Mitigated
	Weekday	Saturday	Sunday	Annual VMT	Annual VMT
Other Non-Asphalt Surfaces	4.02	0.00	0.00	49,100	49,100
Total	4.02	0.00	0.00	49,100	49,100

4.3 Trip Type Information

Land Use	Miles			Trip %			Trip Purpose %		
	H-W or C-W	H-S or C-C	H-O or C-NW	H-W or C-W	H-S or C-C	H-O or C-NW	Primary	Diverted	Pass-by
Other Non-Asphalt Surfaces	47.00	47.00	47.00	0.00	100.00	0.00	100	0	0

4.4 Fleet Mix

Land Use	LDA	LDT1	LDT2	MDV	LHD1	LHD2	MHD	HHD	OBUS	UBUS	MCY	SBUS	MH
Other Non-Asphalt Surfaces	0.000000	0.000000	0.000000	0.000000	0.000000	0.000000	0.000000	1.000000	0.000000	0.000000	0.000000	0.000000	0.000000

Northstar #1 Project - MITIGATED - Imperial County, Annual

EMFAC Off-Model Adjustment Factors for Gasoline Light Duty Vehicle to Account for the SAFE Vehicle Rule Not Applied

5.0 Energy Detail

Historical Energy Use: N

5.1 Mitigation Measures Energy

	ROG	NOx	CO	SO2	Fugitive PM10	Exhaust PM10	PM10 Total	Fugitive PM2.5	Exhaust PM2.5	PM2.5 Total	Bio- CO2	NBio- CO2	Total CO2	CH4	N2O	CO2e
Category	tons/yr										MT/yr					
Electricity Mitigated						0.0000	0.0000		0.0000	0.0000	0.0000	0.0000	0.0000	0.0000	0.0000	0.0000
Electricity Unmitigated						0.0000	0.0000		0.0000	0.0000	0.0000	0.0000	0.0000	0.0000	0.0000	0.0000
NaturalGas Mitigated	0.0000	0.0000	0.0000	0.0000		0.0000	0.0000		0.0000	0.0000	0.0000	0.0000	0.0000	0.0000	0.0000	0.0000
NaturalGas Unmitigated	0.0000	0.0000	0.0000	0.0000		0.0000	0.0000		0.0000	0.0000	0.0000	0.0000	0.0000	0.0000	0.0000	0.0000

Northstar #1 Project - MITIGATED - Imperial County, Annual

EMFAC Off-Model Adjustment Factors for Gasoline Light Duty Vehicle to Account for the SAFE Vehicle Rule Not Applied

5.3 Energy by Land Use - Electricity

Unmitigated

	Electricity Use	Total CO2	CH4	N2O	CO2e
Land Use	kWh/yr	MT/yr			
Other Non-Asphalt Surfaces	0	0.0000	0.0000	0.0000	0.0000
Total		0.0000	0.0000	0.0000	0.0000

Mitigated

	Electricity Use	Total CO2	CH4	N2O	CO2e
Land Use	kWh/yr	MT/yr			
Other Non-Asphalt Surfaces	0	0.0000	0.0000	0.0000	0.0000
Total		0.0000	0.0000	0.0000	0.0000

6.0 Area Detail

6.1 Mitigation Measures Area

Northstar #1 Project - MITIGATED - Imperial County, Annual

EMFAC Off-Model Adjustment Factors for Gasoline Light Duty Vehicle to Account for the SAFE Vehicle Rule Not Applied

	ROG	NOx	CO	SO2	Fugitive PM10	Exhaust PM10	PM10 Total	Fugitive PM2.5	Exhaust PM2.5	PM2.5 Total	Bio- CO2	NBio- CO2	Total CO2	CH4	N2O	CO2e
Category	tons/yr										MT/yr					
Mitigated	1.0691	2.0000e-005	2.6300e-003	0.0000		1.0000e-005	1.0000e-005		1.0000e-005	1.0000e-005	0.0000	5.1300e-003	5.1300e-003	1.0000e-005	0.0000	5.4600e-003
Unmitigated	1.0691	2.0000e-005	2.6300e-003	0.0000		1.0000e-005	1.0000e-005		1.0000e-005	1.0000e-005	0.0000	5.1300e-003	5.1300e-003	1.0000e-005	0.0000	5.4600e-003

6.2 Area by SubCategory

Unmitigated

	ROG	NOx	CO	SO2	Fugitive PM10	Exhaust PM10	PM10 Total	Fugitive PM2.5	Exhaust PM2.5	PM2.5 Total	Bio- CO2	NBio- CO2	Total CO2	CH4	N2O	CO2e
SubCategory	tons/yr										MT/yr					
Architectural Coating	0.2608					0.0000	0.0000		0.0000	0.0000	0.0000	0.0000	0.0000	0.0000	0.0000	0.0000
Consumer Products	0.8081					0.0000	0.0000		0.0000	0.0000	0.0000	0.0000	0.0000	0.0000	0.0000	0.0000
Landscaping	2.4000e-004	2.0000e-005	2.6300e-003	0.0000		1.0000e-005	1.0000e-005		1.0000e-005	1.0000e-005	0.0000	5.1300e-003	5.1300e-003	1.0000e-005	0.0000	5.4600e-003
Total	1.0691	2.0000e-005	2.6300e-003	0.0000		1.0000e-005	1.0000e-005		1.0000e-005	1.0000e-005	0.0000	5.1300e-003	5.1300e-003	1.0000e-005	0.0000	5.4600e-003

Northstar #1 Project - MITIGATED - Imperial County, Annual

EMFAC Off-Model Adjustment Factors for Gasoline Light Duty Vehicle to Account for the SAFE Vehicle Rule Not Applied

6.2 Area by SubCategory

Mitigated

	ROG	NOx	CO	SO2	Fugitive PM10	Exhaust PM10	PM10 Total	Fugitive PM2.5	Exhaust PM2.5	PM2.5 Total	Bio- CO2	NBio- CO2	Total CO2	CH4	N2O	CO2e
SubCategory	tons/yr										MT/yr					
Architectural Coating	0.2608					0.0000	0.0000		0.0000	0.0000	0.0000	0.0000	0.0000	0.0000	0.0000	0.0000
Consumer Products	0.8081					0.0000	0.0000		0.0000	0.0000	0.0000	0.0000	0.0000	0.0000	0.0000	0.0000
Landscaping	2.4000e-004	2.0000e-005	2.6300e-003	0.0000		1.0000e-005	1.0000e-005		1.0000e-005	1.0000e-005	0.0000	5.1300e-003	5.1300e-003	1.0000e-005	0.0000	5.4600e-003
Total	1.0691	2.0000e-005	2.6300e-003	0.0000		1.0000e-005	1.0000e-005		1.0000e-005	1.0000e-005	0.0000	5.1300e-003	5.1300e-003	1.0000e-005	0.0000	5.4600e-003

7.0 Water Detail

7.1 Mitigation Measures Water

Northstar #1 Project - MITIGATED - Imperial County, Annual

EMFAC Off-Model Adjustment Factors for Gasoline Light Duty Vehicle to Account for the SAFE Vehicle Rule Not Applied

	Total CO2	CH4	N2O	CO2e
Category	MT/yr			
Mitigated	0.0000	0.0000	0.0000	0.0000
Unmitigated	0.0000	0.0000	0.0000	0.0000

7.2 Water by Land Use

Unmitigated

	Indoor/Outdoor Use	Total CO2	CH4	N2O	CO2e
Land Use	Mgal	MT/yr			
Other Non-Asphalt Surfaces	0 / 0	0.0000	0.0000	0.0000	0.0000
Total		0.0000	0.0000	0.0000	0.0000

Northstar #1 Project - MITIGATED - Imperial County, Annual

EMFAC Off-Model Adjustment Factors for Gasoline Light Duty Vehicle to Account for the SAFE Vehicle Rule Not Applied

7.2 Water by Land Use

Mitigated

	Indoor/Outdoor Use	Total CO2	CH4	N2O	CO2e
Land Use	Mgal	MT/yr			
Other Non-Asphalt Surfaces	0 / 0	0.0000	0.0000	0.0000	0.0000
Total		0.0000	0.0000	0.0000	0.0000

8.0 Waste Detail

8.1 Mitigation Measures Waste

Category/Year

	Total CO2	CH4	N2O	CO2e
	MT/yr			
Mitigated	0.0000	0.0000	0.0000	0.0000
Unmitigated	0.0000	0.0000	0.0000	0.0000

Northstar #1 Project - MITIGATED - Imperial County, Annual

EMFAC Off-Model Adjustment Factors for Gasoline Light Duty Vehicle to Account for the SAFE Vehicle Rule Not Applied

8.2 Waste by Land Use

Unmitigated

	Waste Disposed	Total CO2	CH4	N2O	CO2e
Land Use	tons	MT/yr			
Other Non-Asphalt Surfaces	0	0.0000	0.0000	0.0000	0.0000
Total		0.0000	0.0000	0.0000	0.0000

Mitigated

	Waste Disposed	Total CO2	CH4	N2O	CO2e
Land Use	tons	MT/yr			
Other Non-Asphalt Surfaces	0	0.0000	0.0000	0.0000	0.0000
Total		0.0000	0.0000	0.0000	0.0000

9.0 Operational Offroad

Equipment Type	Number	Hours/Day	Days/Year	Horse Power	Load Factor	Fuel Type
----------------	--------	-----------	-----------	-------------	-------------	-----------

Northstar #1 Project - MITIGATED - Imperial County, Annual

EMFAC Off-Model Adjustment Factors for Gasoline Light Duty Vehicle to Account for the SAFE Vehicle Rule Not Applied

10.0 Stationary Equipment

Fire Pumps and Emergency Generators

Equipment Type	Number	Hours/Day	Hours/Year	Horse Power	Load Factor	Fuel Type
----------------	--------	-----------	------------	-------------	-------------	-----------

Boilers

Equipment Type	Number	Heat Input/Day	Heat Input/Year	Boiler Rating	Fuel Type
----------------	--------	----------------	-----------------	---------------	-----------

User Defined Equipment

Equipment Type	Number
----------------	--------

11.0 Vegetation

Northstar #1 Project - UNMITIGATED - Imperial County, Annual

EMFAC Off-Model Adjustment Factors for Gasoline Light Duty Vehicle to Account for the SAFE Vehicle Rule Not Applied

**Northstar #1 Project - UNMITIGATED
Imperial County, Annual**

1.0 Project Characteristics

1.1 Land Usage

Land Uses	Size	Metric	Lot Acreage	Floor Surface Area	Population
Other Non-Asphalt Surfaces	287.00	Acre	287.00	12,501,720.00	0

1.2 Other Project Characteristics

Urbanization	Rural	Wind Speed (m/s)	3.4	Precipitation Freq (Days)	12
Climate Zone	15			Operational Year	2024
Utility Company	Imperial Irrigation District				
CO2 Intensity (lb/MWhr)	189.98	CH4 Intensity (lb/MWhr)	0.033	N2O Intensity (lb/MWhr)	0.004

1.3 User Entered Comments & Non-Default Data

Project Characteristics -

Land Use -

Construction Phase - Days of construction based on previous Z Global solar generation facility projects in Imperial County

Off-road Equipment - Equipment derived from previous Z Global solar generation facilities in Imperial County

Off-road Equipment - Ibid

Off-road Equipment - Ibid

Grading -

Construction Off-road Equipment Mitigation - ICAPCD Regulation VIII applied.

Vehicle Trips - Assume 4 heavy duty trucks trips daily

Trips and VMT - Maximum 75 workers assumed. Commute miles derived from an averaged distance between the Project Site and Brawley and the Project Site and Palm Springs [47 miles]

On-road Fugitive Dust - 1.15 miles of Project access is unpaved. Equates to 2.4 percent of 47 mile route.

Northstar #1 Project - UNMITIGATED - Imperial County, Annual

EMFAC Off-Model Adjustment Factors for Gasoline Light Duty Vehicle to Account for the SAFE Vehicle Rule Not Applied

Road Dust - 1.15 miles of site access unpaved. Equates to 2.4 percent of the route

Fleet Mix - Assume 100% heavy duty truck fleet mix

Table Name	Column Name	Default Value	New Value
tblConstructionPhase	NumDays	4,650.00	85.00
tblConstructionPhase	NumDays	465.00	120.00
tblConstructionPhase	NumDays	180.00	60.00
tblConstructionPhase	PhaseEndDate	10/22/2043	3/5/2024
tblConstructionPhase	PhaseEndDate	12/25/2025	11/7/2023
tblConstructionPhase	PhaseEndDate	3/14/2024	5/23/2023
tblConstructionPhase	PhaseStartDate	12/26/2025	11/8/2023
tblConstructionPhase	PhaseStartDate	3/15/2024	5/24/2023
tblConstructionPhase	PhaseStartDate	7/7/2023	3/1/2023
tblFleetMix	HHD	0.02	1.00
tblFleetMix	LDA	0.53	0.00
tblFleetMix	LDT1	0.06	0.00
tblFleetMix	LDT2	0.18	0.00
tblFleetMix	LHD1	0.03	0.00
tblFleetMix	LHD2	6.8510e-003	0.00
tblFleetMix	MCY	0.02	0.00
tblFleetMix	MDV	0.15	0.00
tblFleetMix	MH	3.5040e-003	0.00
tblFleetMix	MHD	8.3160e-003	0.00
tblFleetMix	OBUS	9.2500e-004	0.00
tblFleetMix	SBUS	7.6600e-004	0.00
tblFleetMix	UBUS	1.2000e-004	0.00
tblOffRoadEquipment	LoadFactor	0.38	0.38
tblOffRoadEquipment	LoadFactor	0.38	0.38
tblOffRoadEquipment	LoadFactor	0.38	0.38
tblOffRoadEquipment	LoadFactor	0.42	0.42

Northstar #1 Project - UNMITIGATED - Imperial County, Annual

EMFAC Off-Model Adjustment Factors for Gasoline Light Duty Vehicle to Account for the SAFE Vehicle Rule Not Applied

tblOffRoadEquipment	LoadFactor	0.36	0.36
tblOffRoadEquipment	LoadFactor	0.38	0.38
tblOffRoadEquipment	LoadFactor	0.40	0.40
tblOffRoadEquipment	LoadFactor	0.50	0.50
tblOffRoadEquipment	OffRoadEquipmentType		Off-Highway Trucks
tblOffRoadEquipment	OffRoadEquipmentType		Off-Highway Trucks
tblOffRoadEquipment	OffRoadEquipmentType		Off-Highway Trucks
tblOffRoadEquipment	OffRoadEquipmentType		Pavers
tblOffRoadEquipment	OffRoadEquipmentType		Paving Equipment
tblOffRoadEquipment	OffRoadEquipmentType		Plate Compactors
tblOffRoadEquipment	OffRoadEquipmentType		Rollers
tblOffRoadEquipment	OffRoadEquipmentType		Rough Terrain Forklifts
tblOffRoadEquipment	OffRoadEquipmentType		Trenchers
tblOffRoadEquipment	OffRoadEquipmentUnitAmount	2.00	4.00
tblOffRoadEquipment	OffRoadEquipmentUnitAmount	3.00	0.00
tblOffRoadEquipment	OffRoadEquipmentUnitAmount	1.00	0.00
tblOffRoadEquipment	OffRoadEquipmentUnitAmount	1.00	3.00
tblOffRoadEquipment	OffRoadEquipmentUnitAmount	1.00	2.00
tblOffRoadEquipment	OffRoadEquipmentUnitAmount	3.00	2.00
tblOffRoadEquipment	OffRoadEquipmentUnitAmount	3.00	4.00
tblOffRoadEquipment	OffRoadEquipmentUnitAmount	2.00	4.00
tblOffRoadEquipment	OffRoadEquipmentUnitAmount	4.00	2.00
tblOnRoadDust	VendorPercentPave	50.00	97.60
tblOnRoadDust	WorkerPercentPave	50.00	97.60
tblOnRoadDust	WorkerPercentPave	50.00	97.60
tblOnRoadDust	WorkerPercentPave	50.00	97.60
tblProjectCharacteristics	UrbanizationLevel	Urban	Rural
tblRoadDust	RoadPercentPave	50	97.6
tblTripsAndVMT	VendorTripLength	11.90	47.00

Northstar #1 Project - UNMITIGATED - Imperial County, Annual

EMFAC Off-Model Adjustment Factors for Gasoline Light Duty Vehicle to Account for the SAFE Vehicle Rule Not Applied

tblTripsAndVMT	VendorTripNumber	2,049.00	10.00
tblTripsAndVMT	WorkerTripLength	10.20	47.00
tblTripsAndVMT	WorkerTripLength	10.20	47.00
tblTripsAndVMT	WorkerTripLength	10.20	47.00
tblTripsAndVMT	WorkerTripNumber	5,251.00	150.00
tblVehicleTrips	CC_TL	9.50	47.00
tblVehicleTrips	CC_TTP	0.00	100.00
tblVehicleTrips	CNW_TL	11.90	47.00
tblVehicleTrips	CW_TL	16.40	47.00
tblVehicleTrips	PR_TP	0.00	100.00
tblVehicleTrips	WD_TR	0.00	0.01

2.0 Emissions Summary

Northstar #1 Project - UNMITIGATED - Imperial County, Annual

EMFAC Off-Model Adjustment Factors for Gasoline Light Duty Vehicle to Account for the SAFE Vehicle Rule Not Applied

2.1 Overall Construction

Unmitigated Construction

	ROG	NOx	CO	SO2	Fugitive PM10	Exhaust PM10	PM10 Total	Fugitive PM2.5	Exhaust PM2.5	PM2.5 Total	Bio- CO2	NBio- CO2	Total CO2	CH4	N2O	CO2e
Year	tons/yr										MT/yr					
2023	0.5902	5.2204	4.9541	0.0119	10.9660	0.2170	11.1830	1.6186	0.1998	1.8183	0.0000	1,054.5283	1,054.5283	0.2867	6.7300e-003	1,063.7018
2024	0.1598	1.0833	1.5651	3.9100e-003	6.1690	0.0460	6.2150	0.6378	0.0425	0.6803	0.0000	347.0307	347.0307	0.0743	5.6300e-003	350.5654
Maximum	0.5902	5.2204	4.9541	0.0119	10.9660	0.2170	11.1830	1.6186	0.1998	1.8183	0.0000	1,054.5283	1,054.5283	0.2867	6.7300e-003	1,063.7018

Mitigated Construction

	ROG	NOx	CO	SO2	Fugitive PM10	Exhaust PM10	PM10 Total	Fugitive PM2.5	Exhaust PM2.5	PM2.5 Total	Bio- CO2	NBio- CO2	Total CO2	CH4	N2O	CO2e
Year	tons/yr										MT/yr					
2023	0.5902	5.2204	4.9541	0.0119	10.1948	0.2170	10.4118	1.2720	0.1998	1.4717	0.0000	1,054.5272	1,054.5272	0.2867	6.7300e-003	1,063.7008
2024	0.1598	1.0833	1.5651	3.9100e-003	6.1690	0.0460	6.2150	0.6378	0.0425	0.6803	0.0000	347.0304	347.0304	0.0743	5.6300e-003	350.5651
Maximum	0.5902	5.2204	4.9541	0.0119	10.1948	0.2170	10.4118	1.2720	0.1998	1.4717	0.0000	1,054.5272	1,054.5272	0.2867	6.7300e-003	1,063.7008

Northstar #1 Project - UNMITIGATED - Imperial County, Annual

EMFAC Off-Model Adjustment Factors for Gasoline Light Duty Vehicle to Account for the SAFE Vehicle Rule Not Applied

	ROG	NOx	CO	SO2	Fugitive PM10	Exhaust PM10	PM10 Total	Fugitive PM2.5	Exhaust PM2.5	PM2.5 Total	Bio- CO2	NBio-CO2	Total CO2	CH4	N2O	CO2e
Percent Reduction	0.00	0.00	0.00	0.00	4.50	0.00	4.43	15.36	0.00	13.87	0.00	0.00	0.00	0.00	0.00	0.00

Quarter	Start Date	End Date	Maximum Unmitigated ROG + NOX (tons/quarter)	Maximum Mitigated ROG + NOX (tons/quarter)
4	2-13-2023	5-12-2023	0.6093	0.6093
5	5-13-2023	8-12-2023	2.0457	2.0457
6	8-13-2023	11-12-2023	2.1980	2.1980
7	11-13-2023	2-12-2024	1.7913	1.7913
8	2-13-2024	5-12-2024	0.4163	0.4163
		Highest	2.1980	2.1980

2.2 Overall Operational

Unmitigated Operational

	ROG	NOx	CO	SO2	Fugitive PM10	Exhaust PM10	PM10 Total	Fugitive PM2.5	Exhaust PM2.5	PM2.5 Total	Bio- CO2	NBio- CO2	Total CO2	CH4	N2O	CO2e
Category	tons/yr										MT/yr					
Area	1.0691	2.0000e-005	2.6300e-003	0.0000		1.0000e-005	1.0000e-005		1.0000e-005	1.0000e-005	0.0000	5.1300e-003	5.1300e-003	1.0000e-005	0.0000	5.4600e-003
Energy	0.0000	0.0000	0.0000	0.0000		0.0000	0.0000		0.0000	0.0000	0.0000	0.0000	0.0000	0.0000	0.0000	0.0000
Mobile	1.7400e-003	0.1099	0.0197	6.2000e-004	0.4595	1.4800e-003	0.4610	0.0494	1.4100e-003	0.0509	0.0000	59.9693	59.9693	1.3000e-004	9.4300e-003	62.7818
Waste						0.0000	0.0000		0.0000	0.0000	0.0000	0.0000	0.0000	0.0000	0.0000	0.0000
Water						0.0000	0.0000		0.0000	0.0000	0.0000	0.0000	0.0000	0.0000	0.0000	0.0000
Total	1.0709	0.1099	0.0223	6.2000e-004	0.4595	1.4900e-003	0.4610	0.0494	1.4200e-003	0.0509	0.0000	59.9745	59.9745	1.4000e-004	9.4300e-003	62.7873

Northstar #1 Project - UNMITIGATED - Imperial County, Annual

EMFAC Off-Model Adjustment Factors for Gasoline Light Duty Vehicle to Account for the SAFE Vehicle Rule Not Applied

2.2 Overall Operational

Mitigated Operational

	ROG	NOx	CO	SO2	Fugitive PM10	Exhaust PM10	PM10 Total	Fugitive PM2.5	Exhaust PM2.5	PM2.5 Total	Bio- CO2	NBio- CO2	Total CO2	CH4	N2O	CO2e
Category	tons/yr										MT/yr					
Area	1.0691	2.0000e-005	2.6300e-003	0.0000		1.0000e-005	1.0000e-005		1.0000e-005	1.0000e-005	0.0000	5.1300e-003	5.1300e-003	1.0000e-005	0.0000	5.4600e-003
Energy	0.0000	0.0000	0.0000	0.0000		0.0000	0.0000		0.0000	0.0000	0.0000	0.0000	0.0000	0.0000	0.0000	0.0000
Mobile	1.7400e-003	0.1099	0.0197	6.2000e-004	0.4595	1.4800e-003	0.4610	0.0494	1.4100e-003	0.0509	0.0000	59.9693	59.9693	1.3000e-004	9.4300e-003	62.7818
Waste						0.0000	0.0000		0.0000	0.0000	0.0000	0.0000	0.0000	0.0000	0.0000	0.0000
Water						0.0000	0.0000		0.0000	0.0000	0.0000	0.0000	0.0000	0.0000	0.0000	0.0000
Total	1.0709	0.1099	0.0223	6.2000e-004	0.4595	1.4900e-003	0.4610	0.0494	1.4200e-003	0.0509	0.0000	59.9745	59.9745	1.4000e-004	9.4300e-003	62.7873

	ROG	NOx	CO	SO2	Fugitive PM10	Exhaust PM10	PM10 Total	Fugitive PM2.5	Exhaust PM2.5	PM2.5 Total	Bio- CO2	NBio- CO2	Total CO2	CH4	N2O	CO2e
Percent Reduction	0.00	0.00	0.00	0.00	0.00	0.00	0.00	0.00	0.00	0.00	0.00	0.00	0.00	0.00	0.00	0.00

3.0 Construction Detail

Construction Phase

Phase Number	Phase Name	Phase Type	Start Date	End Date	Num Days Week	Num Days	Phase Description
1	Site Preparation	Site Preparation	3/1/2023	5/23/2023	5	60	
2	Grading	Grading	5/24/2023	11/7/2023	5	120	
3	Building Construction	Building Construction	11/8/2023	3/5/2024	5	85	

Northstar #1 Project - UNMITIGATED - Imperial County, Annual

EMFAC Off-Model Adjustment Factors for Gasoline Light Duty Vehicle to Account for the SAFE Vehicle Rule Not Applied

Acres of Grading (Site Preparation Phase): 60

Acres of Grading (Grading Phase): 540

Acres of Paving: 287

Residential Indoor: 0; Residential Outdoor: 0; Non-Residential Indoor: 0; Non-Residential Outdoor: 0; Striped Parking Area: 0 (Architectural Coating – sqft)

OffRoad Equipment

Phase Name	Offroad Equipment Type	Amount	Usage Hours	Horse Power	Load Factor
Site Preparation	Off-Highway Trucks	1	8.00	402	0.38
Grading	Off-Highway Trucks	1	8.00	402	0.38
Building Construction	Cranes	1	7.00	231	0.29
Building Construction	Off-Highway Trucks	4	8.00	402	0.38
Grading	Excavators	4	8.00	158	0.38
Building Construction	Forklifts	0	8.00	89	0.20
Building Construction	Generator Sets	0	8.00	84	0.74
Grading	Graders	3	8.00	187	0.41
Building Construction	Pavers	1	8.00	130	0.42
Building Construction	Paving Equipment	2	8.00	132	0.36
Building Construction	Plate Compactors	4	8.00	8	0.43
Building Construction	Rollers	2	8.00	80	0.38
Grading	Rubber Tired Dozers	2	8.00	247	0.40
Site Preparation	Rubber Tired Dozers	2	8.00	247	0.40
Grading	Scrapers	2	8.00	367	0.48
Building Construction	Tractors/Loaders/Backhoes	4	7.00	97	0.37
Grading	Tractors/Loaders/Backhoes	4	8.00	97	0.37
Site Preparation	Tractors/Loaders/Backhoes	2	8.00	97	0.37
Building Construction	Welders	1	8.00	46	0.45
Building Construction	Rough Terrain Forklifts	4	8.00	100	0.40

Northstar #1 Project - UNMITIGATED - Imperial County, Annual

EMFAC Off-Model Adjustment Factors for Gasoline Light Duty Vehicle to Account for the SAFE Vehicle Rule Not Applied

Building Construction	Trenchers	2	8.00	78	0.50
-----------------------	-----------	---	------	----	------

Trips and VMT

Phase Name	Offroad Equipment Count	Worker Trip Number	Vendor Trip Number	Hauling Trip Number	Worker Trip Length	Vendor Trip Length	Hauling Trip Length	Worker Vehicle Class	Vendor Vehicle Class	Hauling Vehicle Class
Site Preparation	5	13.00	0.00	0.00	47.00	11.90	20.00	LD_Mix	HDT_Mix	HHDT
Grading	16	40.00	0.00	0.00	47.00	11.90	20.00	LD_Mix	HDT_Mix	HHDT
Building Construction	25	150.00	10.00	0.00	47.00	47.00	20.00	LD_Mix	HDT_Mix	HHDT

3.1 Mitigation Measures Construction

Water Exposed Area

Reduce Vehicle Speed on Unpaved Roads

3.2 Site Preparation - 2023

Unmitigated Construction On-Site

	ROG	NOx	CO	SO2	Fugitive PM10	Exhaust PM10	PM10 Total	Fugitive PM2.5	Exhaust PM2.5	PM2.5 Total	Bio- CO2	NBio- CO2	Total CO2	CH4	N2O	CO2e
Category	tons/yr										MT/yr					
Fugitive Dust					0.3931	0.0000	0.3931	0.2021	0.0000	0.2021	0.0000	0.0000	0.0000	0.0000	0.0000	0.0000
Off-Road	0.0654	0.6273	0.4194	1.1000e-003		0.0277	0.0277		0.0255	0.0255	0.0000	96.4367	96.4367	0.0312	0.0000	97.2164
Total	0.0654	0.6273	0.4194	1.1000e-003	0.3931	0.0277	0.4208	0.2021	0.0255	0.2275	0.0000	96.4367	96.4367	0.0312	0.0000	97.2164

Northstar #1 Project - UNMITIGATED - Imperial County, Annual

EMFAC Off-Model Adjustment Factors for Gasoline Light Duty Vehicle to Account for the SAFE Vehicle Rule Not Applied

3.2 Site Preparation - 2023

Unmitigated Construction Off-Site

	ROG	NOx	CO	SO2	Fugitive PM10	Exhaust PM10	PM10 Total	Fugitive PM2.5	Exhaust PM2.5	PM2.5 Total	Bio- CO2	NBio- CO2	Total CO2	CH4	N2O	CO2e
Category	tons/yr										MT/yr					
Hauling	0.0000	0.0000	0.0000	0.0000	0.0000	0.0000	0.0000	0.0000	0.0000	0.0000	0.0000	0.0000	0.0000	0.0000	0.0000	0.0000
Vendor	0.0000	0.0000	0.0000	0.0000	0.0000	0.0000	0.0000	0.0000	0.0000	0.0000	0.0000	0.0000	0.0000	0.0000	0.0000	0.0000
Worker	4.6100e-003	3.5300e-003	0.0433	1.2000e-004	0.6397	6.0000e-005	0.6397	0.0661	6.0000e-005	0.0661	0.0000	10.5804	10.5804	2.0000e-004	2.7000e-004	10.6671
Total	4.6100e-003	3.5300e-003	0.0433	1.2000e-004	0.6397	6.0000e-005	0.6397	0.0661	6.0000e-005	0.0661	0.0000	10.5804	10.5804	2.0000e-004	2.7000e-004	10.6671

Mitigated Construction On-Site

	ROG	NOx	CO	SO2	Fugitive PM10	Exhaust PM10	PM10 Total	Fugitive PM2.5	Exhaust PM2.5	PM2.5 Total	Bio- CO2	NBio- CO2	Total CO2	CH4	N2O	CO2e
Category	tons/yr										MT/yr					
Fugitive Dust					0.1769	0.0000	0.1769	0.0909	0.0000	0.0909	0.0000	0.0000	0.0000	0.0000	0.0000	0.0000
Off-Road	0.0654	0.6273	0.4194	1.1000e-003		0.0277	0.0277		0.0255	0.0255	0.0000	96.4366	96.4366	0.0312	0.0000	97.2163
Total	0.0654	0.6273	0.4194	1.1000e-003	0.1769	0.0277	0.2046	0.0909	0.0255	0.1164	0.0000	96.4366	96.4366	0.0312	0.0000	97.2163

Northstar #1 Project - UNMITIGATED - Imperial County, Annual

EMFAC Off-Model Adjustment Factors for Gasoline Light Duty Vehicle to Account for the SAFE Vehicle Rule Not Applied

3.2 Site Preparation - 2023

Mitigated Construction Off-Site

	ROG	NOx	CO	SO2	Fugitive PM10	Exhaust PM10	PM10 Total	Fugitive PM2.5	Exhaust PM2.5	PM2.5 Total	Bio- CO2	NBio- CO2	Total CO2	CH4	N2O	CO2e
Category	tons/yr										MT/yr					
Hauling	0.0000	0.0000	0.0000	0.0000	0.0000	0.0000	0.0000	0.0000	0.0000	0.0000	0.0000	0.0000	0.0000	0.0000	0.0000	0.0000
Vendor	0.0000	0.0000	0.0000	0.0000	0.0000	0.0000	0.0000	0.0000	0.0000	0.0000	0.0000	0.0000	0.0000	0.0000	0.0000	0.0000
Worker	4.6100e-003	3.5300e-003	0.0433	1.2000e-004	0.6397	6.0000e-005	0.6397	0.0661	6.0000e-005	0.0661	0.0000	10.5804	10.5804	2.0000e-004	2.7000e-004	10.6671
Total	4.6100e-003	3.5300e-003	0.0433	1.2000e-004	0.6397	6.0000e-005	0.6397	0.0661	6.0000e-005	0.0661	0.0000	10.5804	10.5804	2.0000e-004	2.7000e-004	10.6671

3.3 Grading - 2023

Unmitigated Construction On-Site

	ROG	NOx	CO	SO2	Fugitive PM10	Exhaust PM10	PM10 Total	Fugitive PM2.5	Exhaust PM2.5	PM2.5 Total	Bio- CO2	NBio- CO2	Total CO2	CH4	N2O	CO2e
Category	tons/yr										MT/yr					
Fugitive Dust					1.0090	0.0000	1.0090	0.4281	0.0000	0.4281	0.0000	0.0000	0.0000	0.0000	0.0000	0.0000
Off-Road	0.3576	3.6422	2.9296	6.8200e-003		0.1488	0.1488		0.1369	0.1369	0.0000	599.2776	599.2776	0.1938	0.0000	604.1231
Total	0.3576	3.6422	2.9296	6.8200e-003	1.0090	0.1488	1.1578	0.4281	0.1369	0.5650	0.0000	599.2776	599.2776	0.1938	0.0000	604.1231

Northstar #1 Project - UNMITIGATED - Imperial County, Annual

EMFAC Off-Model Adjustment Factors for Gasoline Light Duty Vehicle to Account for the SAFE Vehicle Rule Not Applied

3.3 Grading - 2023

Unmitigated Construction Off-Site

	ROG	NOx	CO	SO2	Fugitive PM10	Exhaust PM10	PM10 Total	Fugitive PM2.5	Exhaust PM2.5	PM2.5 Total	Bio- CO2	NBio- CO2	Total CO2	CH4	N2O	CO2e
Category	tons/yr										MT/yr					
Hauling	0.0000	0.0000	0.0000	0.0000	0.0000	0.0000	0.0000	0.0000	0.0000	0.0000	0.0000	0.0000	0.0000	0.0000	0.0000	0.0000
Vendor	0.0000	0.0000	0.0000	0.0000	0.0000	0.0000	0.0000	0.0000	0.0000	0.0000	0.0000	0.0000	0.0000	0.0000	0.0000	0.0000
Worker	0.0284	0.0217	0.2664	7.1000e-004	3.9365	3.8000e-004	3.9369	0.4066	3.5000e-004	0.4070	0.0000	65.1104	65.1104	1.2300e-003	1.6900e-003	65.6439
Total	0.0284	0.0217	0.2664	7.1000e-004	3.9365	3.8000e-004	3.9369	0.4066	3.5000e-004	0.4070	0.0000	65.1104	65.1104	1.2300e-003	1.6900e-003	65.6439

Mitigated Construction On-Site

	ROG	NOx	CO	SO2	Fugitive PM10	Exhaust PM10	PM10 Total	Fugitive PM2.5	Exhaust PM2.5	PM2.5 Total	Bio- CO2	NBio- CO2	Total CO2	CH4	N2O	CO2e
Category	tons/yr										MT/yr					
Fugitive Dust					0.4540	0.0000	0.4540	0.1927	0.0000	0.1927	0.0000	0.0000	0.0000	0.0000	0.0000	0.0000
Off-Road	0.3576	3.6422	2.9296	6.8200e-003		0.1488	0.1488		0.1369	0.1369	0.0000	599.2769	599.2769	0.1938	0.0000	604.1223
Total	0.3576	3.6422	2.9296	6.8200e-003	0.4540	0.1488	0.6028	0.1927	0.1369	0.3296	0.0000	599.2769	599.2769	0.1938	0.0000	604.1223

Northstar #1 Project - UNMITIGATED - Imperial County, Annual

EMFAC Off-Model Adjustment Factors for Gasoline Light Duty Vehicle to Account for the SAFE Vehicle Rule Not Applied

3.3 Grading - 2023

Mitigated Construction Off-Site

	ROG	NOx	CO	SO2	Fugitive PM10	Exhaust PM10	PM10 Total	Fugitive PM2.5	Exhaust PM2.5	PM2.5 Total	Bio- CO2	NBio- CO2	Total CO2	CH4	N2O	CO2e
Category	tons/yr										MT/yr					
Hauling	0.0000	0.0000	0.0000	0.0000	0.0000	0.0000	0.0000	0.0000	0.0000	0.0000	0.0000	0.0000	0.0000	0.0000	0.0000	0.0000
Vendor	0.0000	0.0000	0.0000	0.0000	0.0000	0.0000	0.0000	0.0000	0.0000	0.0000	0.0000	0.0000	0.0000	0.0000	0.0000	0.0000
Worker	0.0284	0.0217	0.2664	7.1000e-004	3.9365	3.8000e-004	3.9369	0.4066	3.5000e-004	0.4070	0.0000	65.1104	65.1104	1.2300e-003	1.6900e-003	65.6439
Total	0.0284	0.0217	0.2664	7.1000e-004	3.9365	3.8000e-004	3.9369	0.4066	3.5000e-004	0.4070	0.0000	65.1104	65.1104	1.2300e-003	1.6900e-003	65.6439

3.4 Building Construction - 2023

Unmitigated Construction On-Site

	ROG	NOx	CO	SO2	Fugitive PM10	Exhaust PM10	PM10 Total	Fugitive PM2.5	Exhaust PM2.5	PM2.5 Total	Bio- CO2	NBio- CO2	Total CO2	CH4	N2O	CO2e
Category	tons/yr										MT/yr					
Off-Road	0.0994	0.8704	0.9711	2.1300e-003		0.0392	0.0392		0.0363	0.0363	0.0000	185.5479	185.5479	0.0587	0.0000	187.0159
Total	0.0994	0.8704	0.9711	2.1300e-003		0.0392	0.0392		0.0363	0.0363	0.0000	185.5479	185.5479	0.0587	0.0000	187.0159

Northstar #1 Project - UNMITIGATED - Imperial County, Annual

EMFAC Off-Model Adjustment Factors for Gasoline Light Duty Vehicle to Account for the SAFE Vehicle Rule Not Applied

3.4 Building Construction - 2023

Unmitigated Construction Off-Site

	ROG	NOx	CO	SO2	Fugitive PM10	Exhaust PM10	PM10 Total	Fugitive PM2.5	Exhaust PM2.5	PM2.5 Total	Bio- CO2	NBio- CO2	Total CO2	CH4	N2O	CO2e
Category	tons/yr										MT/yr					
Hauling	0.0000	0.0000	0.0000	0.0000	0.0000	0.0000	0.0000	0.0000	0.0000	0.0000	0.0000	0.0000	0.0000	0.0000	0.0000	0.0000
Vendor	1.2500e-003	0.0294	7.9400e-003	2.1000e-004	0.3131	3.6000e-004	0.3135	0.0328	3.5000e-004	0.0331	0.0000	20.2566	20.2566	5.0000e-005	2.7700e-003	21.0832
Worker	0.0337	0.0258	0.3163	8.4000e-004	4.6746	4.5000e-004	4.6750	0.4829	4.2000e-004	0.4833	0.0000	77.3186	77.3186	1.4600e-003	2.0000e-003	77.9521
Total	0.0349	0.0553	0.3243	1.0500e-003	4.9877	8.1000e-004	4.9885	0.5157	7.7000e-004	0.5164	0.0000	97.5753	97.5753	1.5100e-003	4.7700e-003	99.0354

Mitigated Construction On-Site

	ROG	NOx	CO	SO2	Fugitive PM10	Exhaust PM10	PM10 Total	Fugitive PM2.5	Exhaust PM2.5	PM2.5 Total	Bio- CO2	NBio- CO2	Total CO2	CH4	N2O	CO2e
Category	tons/yr										MT/yr					
Off-Road	0.0994	0.8704	0.9711	2.1300e-003		0.0392	0.0392		0.0363	0.0363	0.0000	185.5477	185.5477	0.0587	0.0000	187.0157
Total	0.0994	0.8704	0.9711	2.1300e-003		0.0392	0.0392		0.0363	0.0363	0.0000	185.5477	185.5477	0.0587	0.0000	187.0157

Northstar #1 Project - UNMITIGATED - Imperial County, Annual

EMFAC Off-Model Adjustment Factors for Gasoline Light Duty Vehicle to Account for the SAFE Vehicle Rule Not Applied

3.4 Building Construction - 2023

Mitigated Construction Off-Site

	ROG	NOx	CO	SO2	Fugitive PM10	Exhaust PM10	PM10 Total	Fugitive PM2.5	Exhaust PM2.5	PM2.5 Total	Bio- CO2	NBio- CO2	Total CO2	CH4	N2O	CO2e
Category	tons/yr										MT/yr					
Hauling	0.0000	0.0000	0.0000	0.0000	0.0000	0.0000	0.0000	0.0000	0.0000	0.0000	0.0000	0.0000	0.0000	0.0000	0.0000	0.0000
Vendor	1.2500e-003	0.0294	7.9400e-003	2.1000e-004	0.3131	3.6000e-004	0.3135	0.0328	3.5000e-004	0.0331	0.0000	20.2566	20.2566	5.0000e-005	2.7700e-003	21.0832
Worker	0.0337	0.0258	0.3163	8.4000e-004	4.6746	4.5000e-004	4.6750	0.4829	4.2000e-004	0.4833	0.0000	77.3186	77.3186	1.4600e-003	2.0000e-003	77.9521
Total	0.0349	0.0553	0.3243	1.0500e-003	4.9877	8.1000e-004	4.9885	0.5157	7.7000e-004	0.5164	0.0000	97.5753	97.5753	1.5100e-003	4.7700e-003	99.0354

3.4 Building Construction - 2024

Unmitigated Construction On-Site

	ROG	NOx	CO	SO2	Fugitive PM10	Exhaust PM10	PM10 Total	Fugitive PM2.5	Exhaust PM2.5	PM2.5 Total	Bio- CO2	NBio- CO2	Total CO2	CH4	N2O	CO2e
Category	tons/yr										MT/yr					
Off-Road	0.1193	1.0190	1.1972	2.6400e-003		0.0450	0.0450		0.0416	0.0416	0.0000	229.5399	229.5399	0.0726	0.0000	231.3552
Total	0.1193	1.0190	1.1972	2.6400e-003		0.0450	0.0450		0.0416	0.0416	0.0000	229.5399	229.5399	0.0726	0.0000	231.3552

Northstar #1 Project - UNMITIGATED - Imperial County, Annual

EMFAC Off-Model Adjustment Factors for Gasoline Light Duty Vehicle to Account for the SAFE Vehicle Rule Not Applied

3.4 Building Construction - 2024

Unmitigated Construction Off-Site

	ROG	NOx	CO	SO2	Fugitive PM10	Exhaust PM10	PM10 Total	Fugitive PM2.5	Exhaust PM2.5	PM2.5 Total	Bio- CO2	NBio- CO2	Total CO2	CH4	N2O	CO2e
Category	tons/yr										MT/yr					
Hauling	0.0000	0.0000	0.0000	0.0000	0.0000	0.0000	0.0000	0.0000	0.0000	0.0000	0.0000	0.0000	0.0000	0.0000	0.0000	0.0000
Vendor	1.4600e-003	0.0363	9.0900e-003	2.6000e-004	0.3873	4.5000e-004	0.3877	0.0405	4.3000e-004	0.0410	0.0000	24.7141	24.7141	6.0000e-005	3.3600e-003	25.7168
Worker	0.0390	0.0281	0.3588	1.0100e-003	5.7817	5.3000e-004	5.7822	0.5973	4.9000e-004	0.5977	0.0000	92.7767	92.7767	1.6200e-003	2.2700e-003	93.4934
Total	0.0404	0.0643	0.3679	1.2700e-003	6.1690	9.8000e-004	6.1700	0.6378	9.2000e-004	0.6387	0.0000	117.4908	117.4908	1.6800e-003	5.6300e-003	119.2102

Mitigated Construction On-Site

	ROG	NOx	CO	SO2	Fugitive PM10	Exhaust PM10	PM10 Total	Fugitive PM2.5	Exhaust PM2.5	PM2.5 Total	Bio- CO2	NBio- CO2	Total CO2	CH4	N2O	CO2e
Category	tons/yr										MT/yr					
Off-Road	0.1193	1.0190	1.1972	2.6400e-003		0.0450	0.0450		0.0416	0.0416	0.0000	229.5396	229.5396	0.0726	0.0000	231.3549
Total	0.1193	1.0190	1.1972	2.6400e-003		0.0450	0.0450		0.0416	0.0416	0.0000	229.5396	229.5396	0.0726	0.0000	231.3549

Northstar #1 Project - UNMITIGATED - Imperial County, Annual

EMFAC Off-Model Adjustment Factors for Gasoline Light Duty Vehicle to Account for the SAFE Vehicle Rule Not Applied

3.4 Building Construction - 2024

Mitigated Construction Off-Site

	ROG	NOx	CO	SO2	Fugitive PM10	Exhaust PM10	PM10 Total	Fugitive PM2.5	Exhaust PM2.5	PM2.5 Total	Bio- CO2	NBio- CO2	Total CO2	CH4	N2O	CO2e
Category	tons/yr										MT/yr					
Hauling	0.0000	0.0000	0.0000	0.0000	0.0000	0.0000	0.0000	0.0000	0.0000	0.0000	0.0000	0.0000	0.0000	0.0000	0.0000	0.0000
Vendor	1.4600e-003	0.0363	9.0900e-003	2.6000e-004	0.3873	4.5000e-004	0.3877	0.0405	4.3000e-004	0.0410	0.0000	24.7141	24.7141	6.0000e-005	3.3600e-003	25.7168
Worker	0.0390	0.0281	0.3588	1.0100e-003	5.7817	5.3000e-004	5.7822	0.5973	4.9000e-004	0.5977	0.0000	92.7767	92.7767	1.6200e-003	2.2700e-003	93.4934
Total	0.0404	0.0643	0.3679	1.2700e-003	6.1690	9.8000e-004	6.1700	0.6378	9.2000e-004	0.6387	0.0000	117.4908	117.4908	1.6800e-003	5.6300e-003	119.2102

Northstar #1 Project - UNMITIGATED - Imperial County, Annual

EMFAC Off-Model Adjustment Factors for Gasoline Light Duty Vehicle to Account for the SAFE Vehicle Rule Not Applied

4.0 Operational Detail - Mobile

4.1 Mitigation Measures Mobile

	ROG	NOx	CO	SO2	Fugitive PM10	Exhaust PM10	PM10 Total	Fugitive PM2.5	Exhaust PM2.5	PM2.5 Total	Bio- CO2	NBio- CO2	Total CO2	CH4	N2O	CO2e
Category	tons/yr										MT/yr					
Mitigated	1.7400e-003	0.1099	0.0197	6.2000e-004	0.4595	1.4800e-003	0.4610	0.0494	1.4100e-003	0.0509	0.0000	59.9693	59.9693	1.3000e-004	9.4300e-003	62.7818
Unmitigated	1.7400e-003	0.1099	0.0197	6.2000e-004	0.4595	1.4800e-003	0.4610	0.0494	1.4100e-003	0.0509	0.0000	59.9693	59.9693	1.3000e-004	9.4300e-003	62.7818

4.2 Trip Summary Information

Land Use	Average Daily Trip Rate			Unmitigated	Mitigated
	Weekday	Saturday	Sunday	Annual VMT	Annual VMT
Other Non-Asphalt Surfaces	4.02	0.00	0.00	49,100	49,100
Total	4.02	0.00	0.00	49,100	49,100

4.3 Trip Type Information

Land Use	Miles			Trip %			Trip Purpose %		
	H-W or C-W	H-S or C-C	H-O or C-NW	H-W or C-W	H-S or C-C	H-O or C-NW	Primary	Diverted	Pass-by
Other Non-Asphalt Surfaces	47.00	47.00	47.00	0.00	100.00	0.00	100	0	0

4.4 Fleet Mix

Land Use	LDA	LDT1	LDT2	MDV	LHD1	LHD2	MHD	HHD	OBUS	UBUS	MCY	SBUS	MH
Other Non-Asphalt Surfaces	0.000000	0.000000	0.000000	0.000000	0.000000	0.000000	0.000000	1.000000	0.000000	0.000000	0.000000	0.000000	0.000000

Northstar #1 Project - UNMITIGATED - Imperial County, Annual

EMFAC Off-Model Adjustment Factors for Gasoline Light Duty Vehicle to Account for the SAFE Vehicle Rule Not Applied

5.0 Energy Detail

Historical Energy Use: N

5.1 Mitigation Measures Energy

	ROG	NOx	CO	SO2	Fugitive PM10	Exhaust PM10	PM10 Total	Fugitive PM2.5	Exhaust PM2.5	PM2.5 Total	Bio- CO2	NBio- CO2	Total CO2	CH4	N2O	CO2e
Category	tons/yr										MT/yr					
Electricity Mitigated						0.0000	0.0000		0.0000	0.0000	0.0000	0.0000	0.0000	0.0000	0.0000	0.0000
Electricity Unmitigated						0.0000	0.0000		0.0000	0.0000	0.0000	0.0000	0.0000	0.0000	0.0000	0.0000
NaturalGas Mitigated	0.0000	0.0000	0.0000	0.0000		0.0000	0.0000		0.0000	0.0000	0.0000	0.0000	0.0000	0.0000	0.0000	0.0000
NaturalGas Unmitigated	0.0000	0.0000	0.0000	0.0000		0.0000	0.0000		0.0000	0.0000	0.0000	0.0000	0.0000	0.0000	0.0000	0.0000

Northstar #1 Project - UNMITIGATED - Imperial County, Annual

EMFAC Off-Model Adjustment Factors for Gasoline Light Duty Vehicle to Account for the SAFE Vehicle Rule Not Applied

5.3 Energy by Land Use - Electricity

Unmitigated

	Electricity Use	Total CO2	CH4	N2O	CO2e
Land Use	kWh/yr	MT/yr			
Other Non-Asphalt Surfaces	0	0.0000	0.0000	0.0000	0.0000
Total		0.0000	0.0000	0.0000	0.0000

Mitigated

	Electricity Use	Total CO2	CH4	N2O	CO2e
Land Use	kWh/yr	MT/yr			
Other Non-Asphalt Surfaces	0	0.0000	0.0000	0.0000	0.0000
Total		0.0000	0.0000	0.0000	0.0000

6.0 Area Detail

6.1 Mitigation Measures Area

Northstar #1 Project - UNMITIGATED - Imperial County, Annual

EMFAC Off-Model Adjustment Factors for Gasoline Light Duty Vehicle to Account for the SAFE Vehicle Rule Not Applied

	ROG	NOx	CO	SO2	Fugitive PM10	Exhaust PM10	PM10 Total	Fugitive PM2.5	Exhaust PM2.5	PM2.5 Total	Bio- CO2	NBio- CO2	Total CO2	CH4	N2O	CO2e
Category	tons/yr										MT/yr					
Mitigated	1.0691	2.0000e-005	2.6300e-003	0.0000		1.0000e-005	1.0000e-005		1.0000e-005	1.0000e-005	0.0000	5.1300e-003	5.1300e-003	1.0000e-005	0.0000	5.4600e-003
Unmitigated	1.0691	2.0000e-005	2.6300e-003	0.0000		1.0000e-005	1.0000e-005		1.0000e-005	1.0000e-005	0.0000	5.1300e-003	5.1300e-003	1.0000e-005	0.0000	5.4600e-003

6.2 Area by SubCategory

Unmitigated

	ROG	NOx	CO	SO2	Fugitive PM10	Exhaust PM10	PM10 Total	Fugitive PM2.5	Exhaust PM2.5	PM2.5 Total	Bio- CO2	NBio- CO2	Total CO2	CH4	N2O	CO2e
SubCategory	tons/yr										MT/yr					
Architectural Coating	0.2608					0.0000	0.0000		0.0000	0.0000	0.0000	0.0000	0.0000	0.0000	0.0000	0.0000
Consumer Products	0.8081					0.0000	0.0000		0.0000	0.0000	0.0000	0.0000	0.0000	0.0000	0.0000	0.0000
Landscaping	2.4000e-004	2.0000e-005	2.6300e-003	0.0000		1.0000e-005	1.0000e-005		1.0000e-005	1.0000e-005	0.0000	5.1300e-003	5.1300e-003	1.0000e-005	0.0000	5.4600e-003
Total	1.0691	2.0000e-005	2.6300e-003	0.0000		1.0000e-005	1.0000e-005		1.0000e-005	1.0000e-005	0.0000	5.1300e-003	5.1300e-003	1.0000e-005	0.0000	5.4600e-003

Northstar #1 Project - UNMITIGATED - Imperial County, Annual

EMFAC Off-Model Adjustment Factors for Gasoline Light Duty Vehicle to Account for the SAFE Vehicle Rule Not Applied

6.2 Area by SubCategory

Mitigated

	ROG	NOx	CO	SO2	Fugitive PM10	Exhaust PM10	PM10 Total	Fugitive PM2.5	Exhaust PM2.5	PM2.5 Total	Bio- CO2	NBio- CO2	Total CO2	CH4	N2O	CO2e
SubCategory	tons/yr										MT/yr					
Architectural Coating	0.2608					0.0000	0.0000		0.0000	0.0000	0.0000	0.0000	0.0000	0.0000	0.0000	0.0000
Consumer Products	0.8081					0.0000	0.0000		0.0000	0.0000	0.0000	0.0000	0.0000	0.0000	0.0000	0.0000
Landscaping	2.4000e-004	2.0000e-005	2.6300e-003	0.0000		1.0000e-005	1.0000e-005		1.0000e-005	1.0000e-005	0.0000	5.1300e-003	5.1300e-003	1.0000e-005	0.0000	5.4600e-003
Total	1.0691	2.0000e-005	2.6300e-003	0.0000		1.0000e-005	1.0000e-005		1.0000e-005	1.0000e-005	0.0000	5.1300e-003	5.1300e-003	1.0000e-005	0.0000	5.4600e-003

7.0 Water Detail

7.1 Mitigation Measures Water

Northstar #1 Project - UNMITIGATED - Imperial County, Annual

EMFAC Off-Model Adjustment Factors for Gasoline Light Duty Vehicle to Account for the SAFE Vehicle Rule Not Applied

	Total CO2	CH4	N2O	CO2e
Category	MT/yr			
Mitigated	0.0000	0.0000	0.0000	0.0000
Unmitigated	0.0000	0.0000	0.0000	0.0000

7.2 Water by Land Use

Unmitigated

	Indoor/Outdoor Use	Total CO2	CH4	N2O	CO2e
Land Use	Mgal	MT/yr			
Other Non-Asphalt Surfaces	0 / 0	0.0000	0.0000	0.0000	0.0000
Total		0.0000	0.0000	0.0000	0.0000

Northstar #1 Project - UNMITIGATED - Imperial County, Annual

EMFAC Off-Model Adjustment Factors for Gasoline Light Duty Vehicle to Account for the SAFE Vehicle Rule Not Applied

7.2 Water by Land Use

Mitigated

	Indoor/Outdoor Use	Total CO2	CH4	N2O	CO2e
Land Use	Mgal	MT/yr			
Other Non-Asphalt Surfaces	0 / 0	0.0000	0.0000	0.0000	0.0000
Total		0.0000	0.0000	0.0000	0.0000

8.0 Waste Detail

8.1 Mitigation Measures Waste

Category/Year

	Total CO2	CH4	N2O	CO2e
	MT/yr			
Mitigated	0.0000	0.0000	0.0000	0.0000
Unmitigated	0.0000	0.0000	0.0000	0.0000

Northstar #1 Project - UNMITIGATED - Imperial County, Annual

EMFAC Off-Model Adjustment Factors for Gasoline Light Duty Vehicle to Account for the SAFE Vehicle Rule Not Applied

8.2 Waste by Land Use

Unmitigated

	Waste Disposed	Total CO2	CH4	N2O	CO2e
Land Use	tons	MT/yr			
Other Non-Asphalt Surfaces	0	0.0000	0.0000	0.0000	0.0000
Total		0.0000	0.0000	0.0000	0.0000

Mitigated

	Waste Disposed	Total CO2	CH4	N2O	CO2e
Land Use	tons	MT/yr			
Other Non-Asphalt Surfaces	0	0.0000	0.0000	0.0000	0.0000
Total		0.0000	0.0000	0.0000	0.0000

9.0 Operational Offroad

Equipment Type	Number	Hours/Day	Days/Year	Horse Power	Load Factor	Fuel Type
----------------	--------	-----------	-----------	-------------	-------------	-----------

Northstar #1 Project - UNMITIGATED - Imperial County, Annual

EMFAC Off-Model Adjustment Factors for Gasoline Light Duty Vehicle to Account for the SAFE Vehicle Rule Not Applied

10.0 Stationary Equipment

Fire Pumps and Emergency Generators

Equipment Type	Number	Hours/Day	Hours/Year	Horse Power	Load Factor	Fuel Type
----------------	--------	-----------	------------	-------------	-------------	-----------

Boilers

Equipment Type	Number	Heat Input/Day	Heat Input/Year	Boiler Rating	Fuel Type
----------------	--------	----------------	-----------------	---------------	-----------

User Defined Equipment

Equipment Type	Number
----------------	--------

11.0 Vegetation

Renewable Energy Emissions Displacement

Table A-1. Renewable Energy Generator Specifications

Megawatt Project	50
Operational Time ¹	25
Annual Hours of Generation ¹	2,190
Annual Kilowatt Hours	109,500,000
Heat Rate ²	9,313
Btu Displaced ³	1,019,773,500,000

Notes:

¹ The Project is assumed to generate electricity 25 percent of the time available (2,190 hours annually).

² Heat Rate indicate the energy generator efficiency of existing fossil-fuel based energy generators. The heat rate of a power plant measures the amount of fuel used to generate one unit of electricity. Power plants with lower heat rates are more efficient than plants with higher heat rates. The CEC's "Updated Thermal Power Plant Efficiency Measures and Operational Characteristics for Production Cost Modeling" (2019) estimates heat rates and operating ranges for thermal power plants supplying energy to California. the average heat rate of power plant types are as follows:

Table A-2. Heat Rates

Steam Boiler Fueled by Coal:	10,800
Steam Boiler Fueled by Natural Gas:	10,200
Gas Turbine:	10,100
Combined Natural Gas Boiler & Turbine:	7,640

Omitting steam boilers fueled by coal since so little of California's energy is derived from coal, the average heat rate =

9313

³ The annual kilowatt hours multiplied by the average heat rate of existing fossil fuel based energy generators equals the amount of Btu displaced from fossil fuel production, as shown in Table A-3.

Table A-3. Btu Displacement

Annual Kilowatt Hours	109,500,000
Average Heat Rate	9,313
Btu Displaced from Fossil Fuel Based Energy Production	1,019,773,500,000

Energy consumption in California is predominately derived from natural gas, followed by renewables, nuclear, unspecified nonrenewable sources, and coal, as shown in Table A-4.

Table A-4. California Energy Mix (percentages)

Natural Gas	37.06
Coal	2.74
Renewables (not including hydroelectric generators)	33.09
Nuclear	9.33
Unspecified nonrenewable sources	5.36

Source: California Energy Commission. 2021. "2020 Total System Electric Generation." <https://www.energy.ca.gov/data-reports/energy-almanac/california-electricity-data/2020-total-system-electric-generation>

For the purposes of this analysis, the percentage of California energy derived from natural gas is added to unspecified nonrenewable sources. Table A-5 identifies the displaced Btu attributable to displaced natural gas and displaced coal.

Table A-5. Btu Displacement by Fossil Fuel Type - Annually

Natural Gas & Unspecified Nonrenewable Sources	432,587,918,700
Coal	27,941,793,900

The heat content of coal is assumed at 24 million Btu per ton of coal burned. Table A-6 shows the tons of displaced burned coal based on this heat content.

Table A-6. Tons of Displaced Burned Coal - Annually

Displaced Coal Burn	1,164
---------------------	-------

Table A-7. Emissions Displacement - Tons per Year⁴

Natural Gas	
Nitrogen Oxide	1.07
Carbon Monoxide	0.32
Coarse Particulate Matter	1.02
Fine Particulate Matter	0.41
Sulfur Dioxide	0.74

Coal	
Nitrogen Oxide	6.99
Carbon Monoxide	0.29
Coarse Particulate Matter	0.05
Fine Particulate Matter	0.03
Sulfur Dioxide	0.33

Table A-8. Total Combined Emissions Displacement - Tons per Year

Natural Gas & Coal	
Nitrogen Oxide	8.06
Carbon Monoxide	0.62
Coarse Particulate Matter	1.07
Fine Particulate Matter	0.45
Sulfur Dioxide	1.07

Table A-9. Total Combined Emissions Displacement over the Life of the Project (30 years) - Tons per Year

Natural Gas & Coal	
Nitrogen Oxide	241.68
Carbon Monoxide	18.47
Coarse Particulate Matter	31.96
Fine Particulate Matter	13.38
Sulfur Dioxide	32.02

⁴Source: Displaced emissions calculated by ECORP Consulting using U.S. EPA's AP-42 Fifth Edition Compilation of Air Emissions Factors 1995; 2015.

Noise Impact Assessment for the North Star 1 Project

County of Imperial, California

Prepared For:

ZGlobal
604 Sutter Street, Suite 250
Folsom, California 95630

Prepared By:

 **ECORP Consulting, Inc.**
ENVIRONMENTAL CONSULTANTS
2525 Warren Drive
Rocklin, California 95677

February 28, 2023

CONTENTS

1.0	INTRODUCTION	1
1.1	Project Overview.....	1
1.2	Project Location.....	1
1.3	Applicable Land Use Regulations	1
1.4	Project Construction	4
2.0	ENVIRONMENTAL NOISE AND GROUNDBORNE VIBRATION ANALYSIS.....	4
2.1	Fundamentals of Noise and Environmental Sound.....	4
2.1.1	Addition of Decibels.....	4
2.1.2	Sound Propagation and Attenuation	4
2.1.3	Noise Descriptors	6
2.1.4	Human Response to Noise.....	8
2.1.5	Effects of Noise on People.....	9
2.2	Fundamentals of Environmental Groundborne Vibration	10
2.2.1	Vibration Sources and Characteristics.....	10
3.0	EXISTING ENVIRONMENTAL NOISE SETTING.....	11
3.1	Noise Sensitive Land Uses	11
3.2	Existing Ambient Noise Environment	11
4.0	REGULATORY FRAMEWORK.....	13
4.1	Federal.....	13
4.1.1	Occupational Safety and Health Act of 1970	13
4.1.2	Federal Interagency Commission on Noise	13
4.2	State	14
4.2.1	State of California General Plan Guidelines	14
4.2.2	State Office of Planning and Research Noise Element Guidelines	14
4.2.3	California Department of Transportation	14
4.3	Local	14
4.3.1	Imperial County General Plan Noise Element.....	14
5.0	IMPACT ASSESSMENT	17
5.1	Thresholds of Significance.....	17
5.2	Methodology	18
5.3	Impact Analysis	19
5.3.1	Would the Project Result in Short-Term Construction-Generated Noise in Excess of County Standards?	19
5.3.2	Would the Project Result in a Substantial Permanent Increase in Ambient Noise Levels in Excess of County Standards During Operations?	21

5.3.3	Would the Project Expose Structures to Substantial Groundborne Vibration During Construction?.....	23
5.3.4	Would the Project Expose Structures to Substantial Groundborne Vibration During Operations?	24
5.3.5	Would the Project Expose People Residing or Working in the Project area to Excessive Airport Noise?.....	24
5.3.6	Cumulative Noise	25
6.0	REFERENCES.....	26

LIST OF TABLES

Table 1.	Common Acoustical Descriptors.....	7
Table 2.	Human Reaction and Damage to Buildings for Continuous or Frequent Intermittent Vibration Levels	11
Table 3.	ANSI Standard 12.9-2013/Part 3 A-weighted Sound Levels Corresponding to Land Use and Population Density.....	12
Table 4.	County of Imperial Property Line Noise Standards	15
Table 5.	County of Imperial Noise/Land Use Compatibility Guidelines.....	16
Table 6.	Construction Average (dBA) Noise Levels at Nearest Receptor	20
Table 7.	Modeled Operational Noise Levels at Nearest Sensitive Receptor.....	23
Table 8.	Representative Vibration Source Levels for Construction Equipment	23
Table 9.	Construction Vibration Levels at 350 Feet.....	24

LIST OF FIGURES

Figure 1.	Project Regional Map.....	2
Figure 2.	Project Vicinity Map.....	3
Figure 3.	Common Noise Levels.....	5
Figure 4.	Project Onsite Noise Source Propagation Map.....	22

APPENDICES

- Appendix A - Federal Highway Administration Highway Roadway Construction Noise Outputs – Project Construction Noise
- Appendix B – SoundPLAN 3-D Noise Model Outputs – Project Onsite Noise

LIST OF ACRONYMS AND ABBREVIATIONS

Term	Definition
APN	Assessor's Parcel Number
Aqueduct	Imperial Irrigation District Aqueduct
BLM	Bureau of Land Management
CEQA	California Environmental Quality Act
County	Imperial County
CNEL	Community Noise Equivalent Level
CUP	Conditional Use Permit
dB	Decibel
dBA	Decibel is A-weighted
FHWA	Federal Highway Administration
FTA	Federal Transit Administration
HSAT	Horizontal Single Axis Tracker
IID	Imperial Irrigation District
L _{eq}	Measure of ambient noise
MWAC	Mega Watt Alternating Current
MWH	Mega Watts Per Hour
OPR	Office of Planning and Research
OSHA	Federal Occupational Safety and Health Administration
OSHPD	Office of State Health Planning and Development
PPV	Peak particle velocity
PV	Photovoltaic
Project	North Star 1 Project
RE Overlay Zone	Renewable Energy and Transmission Overlay Zone
RMS	Root mean square
S-2	Open Space/Preservation
SR	State Route

1.0 INTRODUCTION

This report documents the results of a Noise Impact Assessment completed for the North Star 1 Project (Project), which includes the construction of a nominal 50-megawatt (MW) alternating current solar photovoltaic (PV) energy generation system with an integrated 75 MW battery storage system spanning approximately 287 acres of land in the County of Imperial, California. This report was prepared as a comparison of predicted Project noise levels to noise standards promulgated by the County of Imperial General Plan Noise Element. The purpose of this report is to estimate Project-generated noise and to determine the level of impact the Project would have on the environment.

1.1 Project Overview

The Project proposes to construct a nominal 50 MW alternating current PV energy generation system, accompanied by a 75 MW battery storage, utilizing either thin film or crystalline solar PV technology modules mounted horizontal single-axis tracker (HSAT) systems. The PV module arrays would be mounted on racks supported by driven piles. The individual PV systems would be arranged in large arrays by placing them in columns spaced approximately 10 feet apart to maximize operational performance and to allow access for panel cleaning and maintenance. Operational water supply for the Project would be trucked in from offsite over the life of the Project.

1.2 Project Location

The total combined Project Site spans approximately 287 acres and is located 6.1 miles north of the unincorporated community of Niland, and approximately 8.2 miles east of the community of Bombay Beach, between the East Highline Canal and Coachella Canal (Figures 1 and 2). The irregular shaped site is bound by vacant desert lands to the west, north, and east, and agricultural land to the south. The Project Site is currently characterized by flat and undeveloped desert landscape.

1.3 Applicable Land Use Regulations

The proposed site is within an S-2 (Open Space/Preservation) area as designated by the Imperial County General Plan and is zoned S-2 (Open Space/Preservation). Pursuant to Section 91703.02 (Conditional Use Permits), Renewable Energy Projects must be located within the Renewable Energy and Transmission Overlay Zone (RE Overlay Zone) and may be permitted only through the issuance of a Conditional Use Permit (CUP) as approved by the Approving Authority unless otherwise allowed by applicable law. An amendment to the County's General Plan, with a zone change to include and classify the Project Site within the RE Overlay Zone; and a CUP to allow construction and operation of the solar energy generation facility with battery storage within the RE Overlay Zone, will be required for Project implementation.

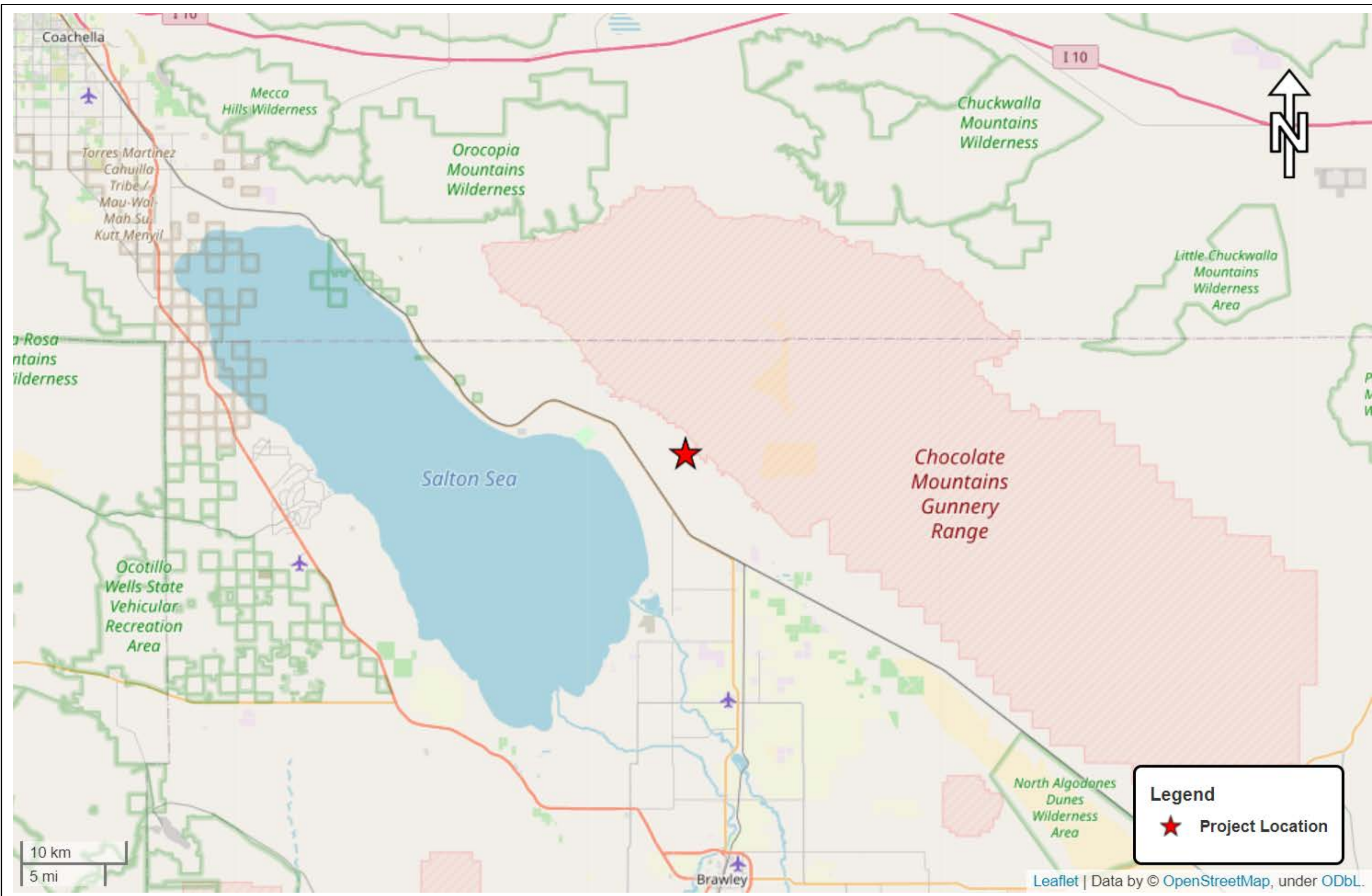

Map Date: 5/12/2022
 Photo (or Base) Source: ECORP Consulting, Inc.

Figure 1. Project Regional Map

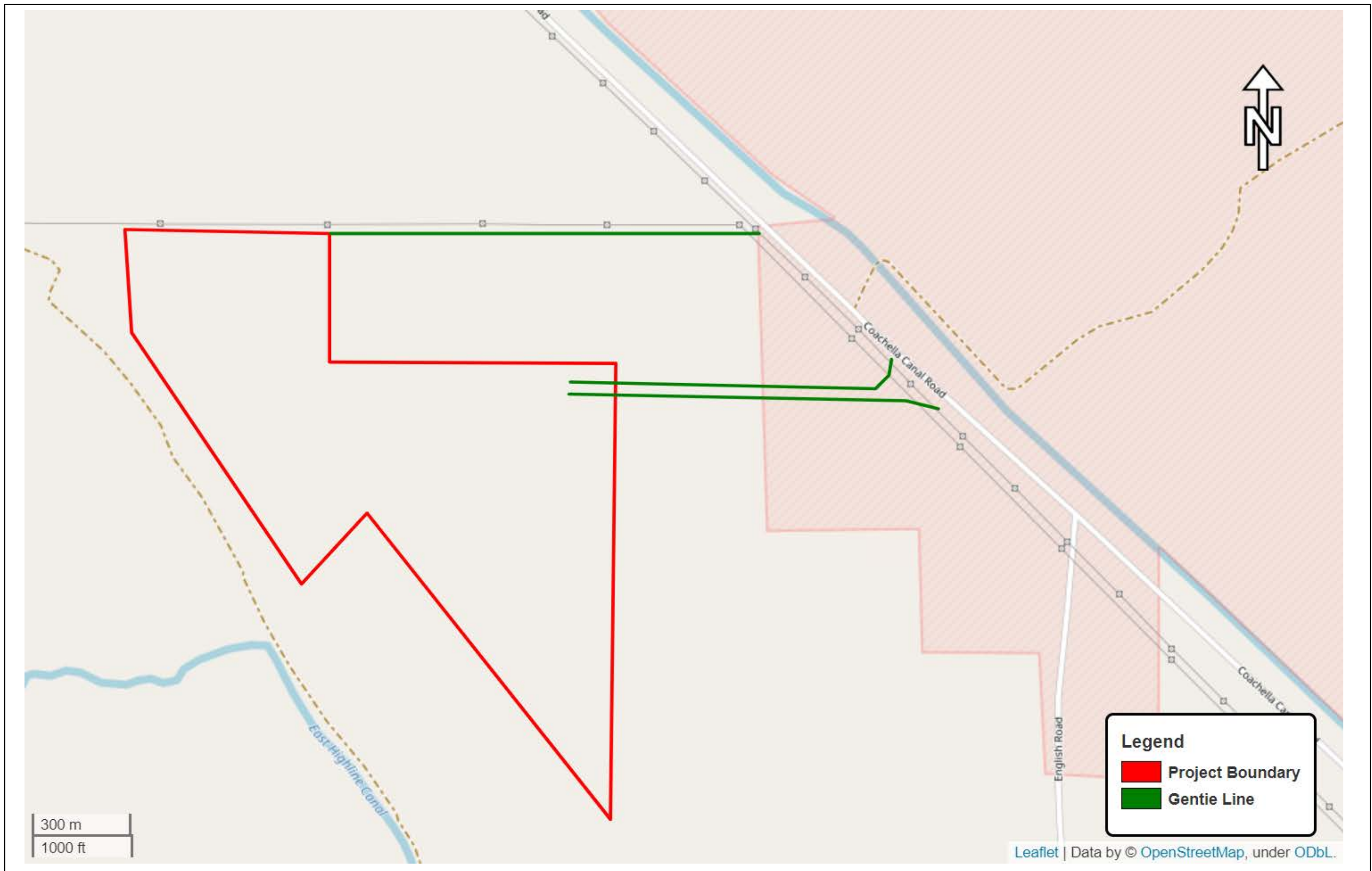

Map Date: 5/12/2022
 Photo (or Base) Source: ECORP Consulting, Inc.

Figure 2. Project Vicinity Map

1.4 Project Construction

Construction activities would involve site preparation and grubbing, grading of the Project Area to establish access roads and pads for electrical equipment (inverters and step-up transformers), trenching for underground electrical collection lines, and the installation of solar equipment and security fencing. The construction of the Project is estimated to take approximately 12 months. A temporary, portable construction supply container would be located at the Project Site at the beginning of construction and removed at the end of construction. Onsite parking would be provided for all construction workers.

2.0 ENVIRONMENTAL NOISE AND GROUNDBORNE VIBRATION ANALYSIS

2.1 Fundamentals of Noise and Environmental Sound

2.1.1 Addition of Decibels

The decibel (dB) scale is logarithmic, not linear, and therefore sound levels cannot be added or subtracted through ordinary arithmetic. Two sound levels 10 dB apart differ in acoustic energy by a factor of 10. When the standard logarithmic decibel is A-weighted (dBA), an increase of 10 dBA is generally perceived as a doubling in loudness. For example, a 70-dBA sound is half as loud as an 80-dBA sound and twice as loud as a 60-dBA sound. When two identical sources are each producing sound of the same loudness, the resulting sound level at a given distance would be three dB higher than one source under the same conditions (Federal Transit Administration [FTA] 2018). For example, a 65-dB source of sound, such as a truck, when joined by another 65 dB source results in a sound amplitude of 68 dB, not 130 dB (i.e., doubling the source strength increases the sound pressure by three dB). Under the decibel scale, three sources of equal loudness together would produce an increase of five dB.

Typical noise levels associated with common noise sources are depicted in Figure 3.

2.1.2 Sound Propagation and Attenuation

Noise can be generated by a number of sources, including mobile sources such as automobiles, trucks and airplanes, and stationary sources such as construction sites, machinery, and industrial operations. Sound spreads (propagates) uniformly outward in a spherical pattern, and the sound level decreases (attenuates) at a rate of approximately 6 dB (dBA) for each doubling of distance from a stationary or point source (FHWA 2017). Sound from a line source, such as a highway, propagates outward in a cylindrical pattern, often referred to as cylindrical spreading. Sound levels attenuate at a rate of approximately 3 dBA for each doubling of distance from a line source, such as a roadway, depending on ground surface characteristics (Federal Highway Administration [FHWA] 2017). No excess attenuation is assumed for hard surfaces like a parking lot or a body of water. Soft surfaces, such as soft dirt or grass, can absorb sound, so an excess ground-attenuation value of 1.5 dBA per doubling of distance is normally assumed. For line sources, an overall attenuation rate of three dB per doubling of distance is assumed (FHWA 2011).

Common Outdoor Activities	Noise Level (dBA)	Common Indoor Activities
<u>Jet Fly-over at 300m (1000 ft)</u>	110	<u>Rock Band</u>
<u>Gas Lawn Mower at 1 m (3 ft)</u>	100	
<u>Diesel Truck at 15 m (50 ft), at 80 km (50 mph)</u>	90	<u>Food Blender at 1 m (3 ft)</u>
<u>Noisy Urban Area, Daytime</u>	80	<u>Garbage Disposal at 1 m (3 ft)</u>
<u>Gas Lawn Mower, 30 m (100 ft)</u>	70	<u>Vacuum Cleaner at 3 m (10 ft)</u>
<u>Commercial Area</u>		<u>Normal Speech at 1 m (3 ft)</u>
<u>Heavy Traffic at 90 m (300 ft)</u>	60	<u>Large Business Office</u>
<u>Quiet Urban Daytime</u>	50	<u>Dishwasher Next Room</u>
<u>Quiet Urban Nighttime</u>	40	<u>Theater, Large Conference Room (Background)</u>
<u>Quiet Suburban Nighttime</u>		<u>Library</u>
<u>Quiet Rural Nighttime</u>	30	<u>Bedroom at Night,</u>
	20	<u>Concert Hall (Background)</u>
	10	<u>Broadcast/Recording Studio</u>
<u>Lowest Threshold of Human Hearing</u>	0	<u>Lowest Threshold of Human Hearing</u>

Source: California Department of Transportation (Caltrans) 2020a

Noise levels may also be reduced by intervening structures; generally, a single row of detached buildings between the receptor and the noise source reduces the noise level by about five dBA (FHWA 2006), while a solid wall or berm generally reduces noise levels by 10 to 20 dBA (FHWA 2011). However, noise barriers or enclosures specifically designed to reduce site-specific construction noise can provide a sound reduction 35 dBA or greater (Western Electro-Acoustic Laboratory, Inc. 2000). To achieve the most potent noise-reducing effect, a noise enclosure/barrier must physically fit in the available space, must completely break the "line of sight" between the noise source and the receptors, must be free of degrading holes or gaps, and must not be flanked by nearby reflective surfaces. Noise barriers must be sizable enough to cover the entire noise source and extend lengthwise and vertically as far as feasibly possible to be most effective. The limiting factor for a noise barrier is not the component of noise transmitted through the material, but rather the amount of noise flanking around and over the barrier. In general, barriers contribute to decreasing noise levels only when the structure breaks the "line of sight" between the source and the receiver.

The manner in which older homes in California were constructed generally provides a reduction of exterior-to-interior noise levels of about 20 to 25 dBA with closed windows (Caltrans 2002). The exterior-to-interior reduction of newer residential units is generally 30 dBA or more (Harris Miller, Miller & Hanson Inc. 2006). Generally, in exterior noise environments ranging from 60 dBA Community Noise Equivalent Level (CNEL) to 65 dBA CNEL, interior noise levels can typically be maintained below 45 dBA, a typical residential interior noise standard, with the incorporation of an adequate forced air mechanical ventilation system in each residential building, and standard thermal-pane residential windows/doors with a minimum rating of Sound Transmission Class (STC) 28. (STC is an integer rating of how well a building partition attenuates airborne sound. In the U.S., it is widely used to rate interior partitions, ceilings, floors, doors, windows, and exterior wall configurations). In exterior noise environments of 65 dBA CNEL or greater, a combination of forced-air mechanical ventilation and sound-rated construction methods is often required to meet the interior noise level limit. Attaining the necessary noise reduction from exterior to interior spaces is readily achievable in noise environments less than 75 dBA CNEL with proper wall construction techniques following California Building Code methods, the selections of proper windows and doors, and the incorporation of forced-air mechanical ventilation systems.

2.1.3 Noise Descriptors

The decibel scale alone does not adequately characterize how humans perceive noise. The dominant frequencies of a sound have a substantial effect on the human response to that sound. Several rating scales have been developed to analyze the adverse effect of community noise on people. Because environmental noise fluctuates over time, these scales consider that the effect of noise on people is largely dependent on the total acoustical energy content of the noise, as well as the time of day when the noise occurs. The noise descriptors most often encountered when dealing with traffic, community, and environmental noise include the average hourly noise level (in L_{eq}) and the average daily noise levels/community noise equivalent level (in L_{dn} /CNEL). The L_{eq} is a measure of ambient noise, while the L_{dn} and CNEL are measures of community noise. Each is applicable to this analysis and defined as follows:

- **Equivalent Noise Level (L_{eq})** is the average acoustic energy content of noise for a stated period of time. Thus, the L_{eq} of a time-varying noise and that of a steady noise are the same if they

deliver the same acoustic energy to the ear during exposure. For evaluating community impacts, this rating scale does not vary, regardless of whether the noise occurs during the day or the night.

- **Day-Night Average (L_{dn})** is a 24-hour average L_{eq} with a 10-dBA “weighting” added to noise during the hours of 10:00 pm to 7:00 am to account for noise sensitivity in the nighttime. The logarithmic effect of these additions is that a 60 dBA 24-hour L_{eq} would result in a measurement of 66.4 dBA L_{dn} .
- **Community Noise Equivalent Level (CNEL)** is a 24-hour average L_{eq} with a 5-dBA weighting during the hours of 7:00 pm to 10:00 pm and a 10-dBA weighting added to noise during the hours of 10:00 pm to 7:00 am to account for noise sensitivity in the evening and nighttime, respectively.

Table 1 provides a list of other common acoustical descriptors.

Table 1. Common Acoustical Descriptors	
Descriptor	Definition
Decibel, dB	A unit describing the amplitude of sound, equal to 20 times the logarithm to the base 10 of the ratio of the pressure of the sound measured to the reference pressure. The reference pressure for air is 20.
Sound Pressure Level	Sound pressure is the sound force per unit area, usually expressed in micropascals (or 20 micronewtons per square meter), where 1 pascal is the pressure resulting from a force of 1 newton exerted over an area of 1 square meter. The sound pressure level is expressed in decibels as 20 times the logarithm to the base 10 of the ratio between the pressures exerted by the sound to a reference sound pressure (e.g., 20 micropascals). Sound pressure level is the quantity that is directly measured by a sound level meter.
Frequency, Hertz (Hz)	The number of complete pressure fluctuations per second above and below atmospheric pressure. Normal human hearing is between 20 Hz and 20,000 Hz. Infrasonic sounds are below 20 Hz and ultrasonic sounds are above 20,000 Hz.
A-Weighted Sound Level, dBA	The sound pressure level in decibels as measured on a sound level meter using the A-weighting filter network. The A-weighting filter de-emphasizes the very low and very high-frequency components of the sound in a manner similar to the frequency response of the human ear and correlates well with subjective reactions to noise.
Equivalent Noise Level, L_{eq}	The average acoustic energy content of noise for a stated period of time. Thus, the L_{eq} of a time-varying noise and that of a steady noise are the same if they deliver the same acoustic energy to the ear during exposure. For evaluating community impacts, this rating scale does not vary, regardless of whether the noise occurs during the day or the night.
L_{max} , L_{min}	The maximum and minimum A-weighted noise level during the measurement period.
L_{01} , L_{10} , L_{50} , L_{90}	The A-weighted noise levels that are exceeded 1%, 10%, 50%, and 90% of the time during the measurement period.
Day/Night Noise Level, L_{dn} or DNL	A 24-hour average L_{eq} with a 10 dBA “weighting” added to noise during the hours of 10:00 p.m. to 7:00 a.m. to account for noise sensitivity in the nighttime. The logarithmic effect of these additions is that a 60 dBA 24-hour L_{eq} would result in a measurement of 66.4 dBA L_{dn} .

Table 1. Common Acoustical Descriptors	
Descriptor	Definition
Community Noise Equivalent Level, CNEL	A 24-hour average Leq with a 5 dBA "weighting" during the hours of 7:00 p.m. to 10:00 p.m. and a 10 dBA "weighting" added to noise during the hours of 10:00 p.m. to 7:00 a.m. to account for noise sensitivity in the evening and nighttime, respectively. The logarithmic effect of these additions is that a 60 dBA 24-hour Leq would result in a measurement of 66.7 dBA CNEL.
Ambient Noise Level	The composite of noise from all sources near and far. The normal or existing level of environmental noise at a given location.
Intrusive	That noise which intrudes over and above the existing ambient noise at a given location. The relative intrusiveness of a sound depends on its amplitude, duration, frequency, and time of occurrence and tonal or informational content, as well as the prevailing ambient noise level.
Decibel, dB	A unit describing the amplitude of sound, equal to 20 times the logarithm to the base 10 of the ratio of the pressure of the sound measured to the reference pressure. The reference pressure for air is 20.

The A-weighted decibel sound level scale gives greater weight to the frequencies of sound to which the human ear is most sensitive. Because sound levels can vary markedly over a short period of time, a method for describing either the average character of the sound or the statistical behavior of the variations must be utilized. Most commonly, environmental sounds are described in terms of an average level that has the same acoustical energy as the summation of all the time-varying events.

The scientific instrument used to measure noise is the sound level meter. Sound level meters can accurately measure environmental noise levels to within about ±1 dBA. Various computer models are used to predict environmental noise levels from sources, such as roadways and airports. The accuracy of the predicted models depends on the distance between the receptor and the noise source. Close to the noise source, the models are accurate to within about ±1 to 2 dBA.

2.1.4 Human Response to Noise

The human response to environmental noise is subjective and varies considerably from individual to individual. Noise in the community has often been cited as a health problem, not in terms of actual physiological damage, such as hearing impairment, but in terms of inhibiting general well-being and contributing to undue stress and annoyance. The health effects of noise in the community arise from interference with human activities, including sleep, speech, recreation, and tasks that demand concentration or coordination. Hearing loss can occur at the highest noise intensity levels.

Noise environments and consequences of human activities are usually well represented by median noise levels during the day or night or over a 24-hour period. Environmental noise levels are generally considered low when the CNEL is below 60 dBA, moderate in the 60 to 70 dBA range, and high above 70 dBA. Examples of low daytime levels are isolated, natural settings with noise levels as low as 20 dBA and quiet, suburban, residential streets with noise levels around 40 dBA. Noise levels above 45 dBA at night can disrupt sleep. Examples of moderate-level noise environments are urban residential or semi-

commercial areas (typically 55 to 60 dBA) and commercial locations (typically 60 dBA). People may consider louder environments adverse, but most will accept the higher levels associated with noisier urban residential or residential-commercial areas (60 to 75 dBA) or dense urban or industrial areas (65 to 80 dBA). Regarding increases in A-weighted noise levels (dBA), the following relationships should be noted in understanding this analysis:

- Except in carefully controlled laboratory experiments, a change of 1 dBA cannot be perceived by humans.
- Outside of the laboratory, a 3-dBA change is considered a just-perceivable difference.
- A change in level of at least 5 dBA is required before any noticeable change in community response would be expected. An increase of 5 dBA is typically considered substantial.
- A 10-dBA change is subjectively heard as an approximate doubling in loudness and would almost certainly cause an adverse change in community response.

2.1.5 Effects of Noise on People

2.1.5.1 Hearing Loss

While physical damage to the ear from an intense noise impulse is rare, a degradation of auditory acuity can occur even within a community noise environment. Hearing loss occurs mainly due to chronic exposure to excessive noise but may be due to a single event such as an explosion. Natural hearing loss associated with aging may also be accelerated from chronic exposure to loud noise.

The Occupational Safety and Health Administration (OSHA) has a noise exposure standard that is set at the noise threshold where hearing loss may occur from long-term exposures. The maximum allowable level is 90 dBA averaged over eight hours. If the noise is above 90 dBA, the allowable exposure time is correspondingly shorter.

2.1.5.2 Annoyance

Attitude surveys are used for measuring the annoyance felt in a community for noises intruding into homes or affecting outdoor activity areas. In these surveys, it was determined that causes for annoyance include interference with speech, radio and television, house vibrations, and interference with sleep and rest. The L_{dn} as a measure of noise has been found to provide a valid correlation of noise level and the percentage of people annoyed. People have been asked to judge the annoyance caused by aircraft noise and ground transportation noise. There continues to be disagreement about the relative annoyance of these different sources.

2.2 Fundamentals of Environmental Groundborne Vibration

2.2.1 Vibration Sources and Characteristics

Sources of earthborne vibrations include natural phenomena (e.g., earthquakes, volcanic eruptions, sea waves, landslides) or manmade causes (explosions, machinery, traffic, trains, construction equipment, etc.). Vibration sources may be continuous (e.g., factory machinery) or transient (e.g., explosions).

Ground vibration consists of rapidly fluctuating motions or waves with an average motion of zero. Several different methods are typically used to quantify vibration amplitude. One is the peak particle velocity (PPV); another is the root mean square (RMS) velocity. The PPV is defined as the maximum instantaneous positive or negative peak of the vibration wave. The RMS velocity is defined as the average of the squared amplitude of the signal. The PPV and RMS vibration velocity amplitudes are used to evaluate human response to vibration.

PPV is generally accepted as the most appropriate descriptor for evaluating the potential for building damage. For human response, however, an average vibration amplitude is more appropriate because it takes time for the human body to respond to the excitation (the human body responds to an average vibration amplitude, not a peak amplitude). Because the average particle velocity over time is zero, the RMS amplitude is typically used to assess human response. The RMS value is the average of the amplitude squared over time, typically a 1- sec. period (FTA 2018).

Table 2 displays the reactions of people and the effects on buildings produced by continuous vibration levels. The annoyance levels shown in the table should be interpreted with care since vibration may be found to be annoying at much lower levels than those listed, depending on the level of activity or the sensitivity of the individual. To sensitive individuals, vibrations approaching the threshold of perception can be annoying. Low-level vibrations frequently cause irritating secondary vibration, such as a slight rattling of windows, doors, or stacked dishes. The rattling sound can give rise to exaggerated vibration complaints, even though there is very little risk of actual structural damage. In high-noise environments, which are more prevalent where groundborne vibration approaches perceptible levels, this rattling phenomenon may also be produced by loud airborne environmental noise causing induced vibration in exterior doors and windows.

Ground vibration can be a concern in instances where buildings shake, and substantial rumblings occur. However, it is unusual for vibration from typical urban sources such as buses and heavy trucks to be perceptible. For instance, heavy-duty trucks generally generate groundborne vibration velocity levels of 0.006 PPV at 50 feet under typical circumstances, which as identified in Table 2 is considered very unlikely to cause damage to buildings of any type. Common sources for groundborne vibration are planes, trains, and construction activities such as earth-moving which requires the use of heavy-duty earth moving equipment.

Table 2. Human Reaction and Damage to Buildings for Continuous or Frequent Intermittent Vibration Levels			
Peak Particle Velocity (inches/second)	Approximate Vibration Velocity Level (VdB)	Human Reaction	Effect on Buildings
0.006–0.019	64–74	Range of threshold of perception	Vibrations unlikely to cause damage of any type
0.08	87	Vibrations readily perceptible	Recommended upper level to which ruins and ancient monuments should be subjected
0.1	92	Level at which continuous vibrations may begin to annoy people, particularly those involved in vibration sensitive activities	Virtually no risk of architectural damage to normal buildings
0.2	94	Vibrations may begin to annoy people in buildings	Threshold at which there is a risk of architectural damage to normal dwellings
0.4–0.6	98–104	Vibrations considered unpleasant by people subjected to continuous vibrations and unacceptable to some people walking on bridges	Architectural damage and possibly minor structural damage

Source: Caltrans 2020b

3.0 EXISTING ENVIRONMENTAL NOISE SETTING

3.1 Noise Sensitive Land Uses

Noise-sensitive land uses are generally considered to include those uses where noise exposure could result in health-related risks to individuals, as well as places where quiet is an essential element of their intended purpose. Residential dwellings are of primary concern because of the potential for increased and prolonged exposure of individuals to both interior and exterior noise levels. Additional land uses such as hospitals, historic sites, cemeteries, and certain recreation areas are considered sensitive to increases in exterior noise levels. Schools, churches, hotels, libraries, and other places where low interior noise levels are essential are also considered noise-sensitive land uses.

The nearest existing noise-sensitive land use to the Project Site is a single-family residence located approximately 450 feet from the western boundary of the North Star 1 Project boundary.

3.2 Existing Ambient Noise Environment

The American National Standards Institute (ANSI) Standard 12.9-2013/Part 3 “Quantities and Procedures for Description and Measurement of Environmental Sound – Part 3: Short-Term Measurements with an

Observer Present” provides a table of approximate background sound levels in L_{dn} , daytime L_{eq} , and nighttime L_{eq} , based on land use and population density. The ANSI standard estimation divides land uses into six distinct categories. Descriptions of these land use categories, along with the typical daytime and nighttime levels, are provided in Table 3. At times, one could reasonably expect the occurrence of periods that are both louder and quieter than the levels listed in the table. ANSI notes, “95% prediction interval [confidence interval] is on the order of +/- 10 dB.” The majority of the Project Area would be considered ambient noise Category 5 or 6.

Table 3. ANSI Standard 12.9-2013/Part 3 A-weighted Sound Levels Corresponding to Land Use and Population Density						
Category	Land Use	Description	People per Square Mile	Typical L_{dn}	Daytime L_{eq}	Nighttime L_{eq}
1	Noisy Commercial & Industrial Areas and Very Noisy Residential Areas	Very heavy traffic conditions, such as in busy, downtown commercial areas; at intersections for mass transportation or other vehicles, including elevated trains, heavy motor trucks, and other heavy traffic; and at street corners where many motor buses and heavy trucks accelerate.	63,840	67 dBA	66 dBA	58 dBA
2	Moderate Commercial & Industrial Areas and Noisy Residential Areas	Heavy traffic areas with conditions similar to Category 1, but with somewhat less traffic; routes of relatively heavy or fast automobile traffic, but where heavy truck traffic is not extremely dense.	20,000	62 dBA	61 dBA	54 dBA
3	Quiet Commercial, Industrial Areas and Normal Urban & Noisy Suburban Residential Areas	Light traffic conditions where no mass-transportation vehicles and relatively few automobiles and trucks pass, and where these vehicles generally travel at moderate speeds; residential areas and commercial streets, and intersections, with little traffic, compose this category.	6,384	57 dBA	55 dBA	49 dBA
4	Quiet Urban & Normal Suburban Residential Areas	These areas are similar to Category 3, but for this group, the background is either distant traffic or is unidentifiable; typically, the population density	2,000	52 dBA	50 dBA	44 dBA

Table 3. ANSI Standard 12.9-2013/Part 3 A-weighted Sound Levels Corresponding to Land Use and Population Density						
		is one-third the density of Category 3.				
5	Quiet Residential Areas	These areas are isolated, far from significant sources of sound, and may be situated in shielded areas, such as a small wooded valley.	638	47 dBA	45 dBA	39 dBA
6	Very Quiet Sparse Suburban or rural Residential Areas	These areas are similar to Category 4 but are usually in sparse suburban or rural areas; and, for this group, there are few if any nearby sources of sound.	200	42 dBA	40 dBA	34 dBA

Source: The American National Standards Institute (ANSI) 2013

4.0 REGULATORY FRAMEWORK

4.1 Federal

4.1.1 Occupational Safety and Health Act of 1970

OSHA regulates onsite noise levels and protects workers from occupational noise exposure. To protect hearing, worker noise exposure is limited to 90 decibels with A-weighting (dBA) over an eight-hour work shift (29 Code of Regulations 1910.95). Employers are required to develop a hearing conservation program when employees are exposed to noise levels exceeding 85 dBA. These programs include provision of hearing protection devices and testing employees for hearing loss on a periodic basis.

4.1.2 Federal Interagency Commission on Noise

The 2000 Federal Interagency Commission on Noise (FICON) findings provide guidance as to the significance of changes in ambient noise levels due to transportation noise sources. FICON recommendations are based on studies that relate aircraft and traffic noise levels to the percentage of persons highly annoyed by the noise. FICON's measure of substantial increase for transportation noise exposure is as follows:

- If the existing ambient noise levels at existing noise-sensitive land uses (e.g. residential, etc.) are less than 60 dBA CNEL and the Project creates a readily perceptible 5 dBA CNEL or greater Project-related noise level increase and the resulting noise level would exceed acceptable exterior noise standards; or
- If the existing noise levels range from 60 to 65 dBA CNEL and the Project creates a barely perceptible 3 dBA CNEL or greater Project-related noise level increase and the resulting noise level would exceed acceptable exterior noise standards; or

- If the existing noise levels already exceed 65 dBA CNEL, and the Project creates a community noise level increase of greater than 1.5 dBA CNEL.

4.2 State

4.2.1 State of California General Plan Guidelines

The State of California regulates vehicular and freeway noise affecting classrooms, sets standards for sound transmission and occupational noise control, and identifies noise insulation standards and airport noise/land-use compatibility criteria. The State of California General Plan Guidelines (State of California 2003), published by the Governor's Office of Planning and Research (OPR), also provides guidance for the acceptability of projects within specific CNEL/ L_{dn} contours. The guidelines also present adjustment factors that may be used in order to arrive at noise acceptability standards that reflect the noise control goals of the community, the particular community's sensitivity to noise, and the community's assessment of the relative importance of noise pollution.

4.2.2 State Office of Planning and Research Noise Element Guidelines

The State OPR *Noise Element Guidelines* include recommended exterior and interior noise level standards for local jurisdictions to identify and prevent the creation of incompatible land uses due to noise. The Noise Element Guidelines contain a Land Use Compatibility table that describes the compatibility of various land uses with a range of environmental noise levels in terms of the CNEL.

4.2.3 California Department of Transportation

In 2020, the California Department of Transportation (Caltrans) published the Transportation and Construction Vibration Manual (Caltrans 2020b). The manual provides general guidance on vibration issues associated with the construction and operation of projects concerning human perception and structural damage. Table 2 above presents recommendations for levels of vibration that could result in damage to structures exposed to continuous vibration.

4.3 Local

4.3.1 Imperial County General Plan Noise Element

The County of Imperial General Plan Noise Element establishes maximum allowable average-hourly noise limits for various land use designations (refer to Table 4). These noise standards are to be applied at the property line of the noise-generating land use. In instances where the adjoining land use designations differ from that of the noise-generating land use, the more restrictive noise standard shall apply. Where the ambient noise level is equal to or exceeds the property line noise standard, the increase of the existing or proposed noise shall not exceed 3 dBA L_{eq} , which is a just-perceivable increase in noise. L_{eq} is defined as the average acoustic energy content of noise for a stated period of time. Thus, the L_{eq} of a time-varying noise and that of a steady noise are the same if they deliver the same acoustic energy to the ear during exposure.

Table 4. County of Imperial Property Line Noise Standards		
Land Use Zone	Time Period	Average-Hourly Noise Level (dBA L_{eq})
Residential	7 a.m. - 10 p.m. 10 p.m. - 7 a.m.	50 45
Multi-residential	7 a.m. - 10 p.m. 10 p.m. - 7 a.m.	55 50
Commercial	7 a.m. - 10 p.m. 10 p.m. - 7 a.m.	60 55
Light Industrial/Industrial Park	Any time	70
General Industrial	Any time	75

Source: Imperial County 2015.

Notes: When the noise-generating property and the receiving property have different uses, the more restrictive standard shall apply. When the ambient noise level is equal to or exceeds the Property Line noise standard, the increase of the existing or proposed noise shall not exceed 3 dBA L_{eq}.

4.3.1.1 Construction Noise Standards

Construction noise, from a single piece of equipment or a combination of equipment, shall not exceed 75 dB L_{eq}, when averaged over an 8-hour period, and measured at the nearest sensitive receptor. This standard assumes a construction period, relative to an individual sensitive receptor of days or weeks. In cases of extended length construction times, the standard may be tightened so as not to exceed 75 dB L_{eq} when averaged over a 1-hour period.

Construction equipment operations are required to be limited to the hours of 7:00 a.m. to 7:00 p.m., Monday through Friday, and 9:00 a.m. to 5:00 p.m. Saturday. No commercial construction operations are permitted on Sunday or holidays. In cases of a person constructing or modifying a residence for himself/herself, and if the work is not being performed as a business, construction equipment operations may be performed on Sundays and holidays between the hours of 9:00 a.m. and 5:00 p.m. Such non-commercial construction activities may be further restricted where disturbing, excessive, or offensive noise causes discomfort or annoyance to reasonable persons of normal sensitivity residing in an area.

4.3.1.2 Significant Increase of Ambient Noise Levels

The increase of noise levels generally results in an adverse impact to the noise environment. The Noise/Land Use Compatibility Guidelines are not intended to allow the increase of ambient noise levels up to the maximum without consideration of feasible noise reduction measures. The following guidelines are established by the County of Imperial for the evaluation of significant noise impact.

- If the future noise level after a project is completed will be within the "normally acceptable" noise levels shown in the Noise/Land Use Compatibility Guidelines, but will result in an increase of 5 dB

CNEL or greater, the project will have a potentially significant noise impact and mitigation measures must be considered.

- If the future noise level after a project is completed will be greater than the "normally acceptable" noise levels shown in the Noise/Land Use Compatibility Guidelines, a noise increase of 3 dB CNEL or greater shall be considered a potentially significant noise impact and mitigation measures must be considered.

4.3.1.3 Noise/Land use Compatibility

The Imperial County General Plan Noise Element Noise/Land Use Compatibility Standards defines the acceptability of a land use in a specified noise environment. Table 5 provides the County of Imperial Noise/Land Use Compatibility Guidelines. When an acoustical analysis is performed, conformance of the proposed project with the Noise/Land Use Compatibility Guidelines will be used to evaluate potential noise impact and will provide criteria for environmental impact findings and conditions for project approval.

Table 5. County of Imperial Noise/Land Use Compatibility Guidelines		
Land Use Category	Community Noise Exposure L_{dn} or CNEL, dB	Acceptability
Residential	< 60	Normally Acceptable
	60 - 70	Conditionally Acceptable
	70 - 75	Normally Unacceptable
	> 75	Clearly Unacceptable
Transient Lodging-Motels, Hotels	< 60	Normally Acceptable
	60 - 75	Conditionally Acceptable
	75 - 80	Normally Unacceptable
	> 80	Clearly Unacceptable
Schools, Libraries, Churches, Hospitals, Nursing Homes	< 60	Normally Acceptable
	60 - 70	Conditionally Acceptable
	70 - 80	Normally Unacceptable
	> 80	Clearly Unacceptable
Auditoriums, Concert Halls, Amphitheaters	< 70	Conditionally Acceptable
	> 70	Clearly Unacceptable
Sports Arenas, Outdoor Spectator Sports	< 70	Conditionally Acceptable
	70 - 75	Normally Unacceptable
	> 75	Clearly Unacceptable

Table 5. County of Imperial Noise/Land Use Compatibility Guidelines		
Land Use Category	Community Noise Exposure L_{dn} or CNEL, dB	Acceptability
Playgrounds, Neighborhood Parks	< 70	Normally Acceptable
	70 - 75	Normally Unacceptable
	> 75	Clearly Unacceptable
Golf Courses, Riding Stables, Water Recreation, Cemeteries	< 70	Normally Acceptable
	70 - 80	Normally Unacceptable
	> 80	Clearly Unacceptable
Office Buildings, Business Commercial and Professional	< 65	Normally Acceptable
	65 - 75	Conditionally Acceptable
	75 - 80	Normally Unacceptable
	> 80	Clearly Unacceptable
Industrial, Manufacturing Utilities, Agriculture	< 70	Normally Acceptable
	70 - 75	Conditionally Acceptable
	75 - 80	Normally Unacceptable
	> 80	Clearly Unacceptable

Source: Imperial County 2015.

Notes: Interpretation (For Land Use Planning Purposes):

Normally Acceptable: Specified land use is satisfactory, based upon the assumption that any buildings involved are of normal conventional construction, without any special noise insulation requirements.

Conditionally Acceptable: New construction or development should be undertaken only after a detailed analysis of the noise reduction requirements is made and needed noise insulation features included in the design

Normally Unacceptable: New construction or development should be discouraged. If new construction or development does proceed, a detailed analysis of the noise reduction requirements must be made and needed noise insulation features included in the design.

Clearly Unacceptable: New construction or development clearly should not be undertaken.

5.0 IMPACT ASSESSMENT

5.1 Thresholds of Significance

The impact analysis provided below is based on the following California Environmental Quality Act Guidelines Appendix G thresholds of significance. The Project would result in a significant noise-related impact if it would produce:

- 1) Generation of a substantial temporary or permanent increase in ambient noise levels in the vicinity of the project in excess of standards established in the local general plan or noise ordinance, or applicable standards of other agencies.
- 2) Generation of excessive groundborne vibration or groundborne noise levels.

- 3) For a project located within the vicinity of a private airstrip or an airport land use plan or, where such a plan has not been adopted, within two miles of a public airport or public use airport, would the project expose people residing or working in the project area to excessive noise levels.

In order to evaluate the potential health-related effects (physical damage to the ear and mental damage from lack of sleep or focus) from construction noise, such noise generated by the Project is compared against the construction-related noise level threshold established by the County. For purposes of this analysis, Project construction noise is compared to the County's construction noise standard of 75 dBA, when averaged over an eight-hour period and measured at the nearest sensitive receptor. The increase in transportation-related noise is compared to the FICON recommendation for evaluating the impact of increased traffic noise. Noise generated onsite is compared against the County's property line standards identified in Table 4.

5.2 Methodology

This analysis of the existing and future noise environments is based on empirical observations. Predicted construction noise levels were calculated utilizing the FHWA's Roadway Construction Noise Model (2006). Groundborne vibration levels associated with construction-related activities for the Project have been evaluated utilizing typical groundborne vibration levels associated with construction equipment. Potential groundborne vibration impacts related to structural damage and human annoyance were evaluated, taking into account the distance from construction activities to nearby structures and typically applied criteria for structural damage and human annoyance.

In order to estimate the worst-case operational noise levels that may occur at the nearest noise-sensitive receptor, onsite operational noise levels have been calculated with the SoundPLAN 3D noise model (which predicts noise propagation from a noise source based on the location, noise level, and frequency spectra of the noise sources as well as the geometry and reflective properties of the local terrain, buildings, and barriers), coupled with noise measurements that were taken by ECORP Consulting, Inc. (ECORP) at an existing solar energy generation facility. Specifically, ECORP conducted a 30-minute reference noise measurement within the IVC solar generation facility in Imperial County with a Larson Davis SoundExpert LxT precision sound-level meter, which satisfies the American National Standards Institute for general environmental noise measurement instrumentation. This reference measurement identified an ambient noise environment of 47.1 dBA at the existing solar energy generation facility (see Attachment D). Therefore, a noise level of 47.1 dBA was employed as the reference noise level in the SoundPLAN 3D noise model to determine noise-level propagation associated with Project operations.

5.3 Impact Analysis

5.3.1 Would the Project Result in Short-Term Construction-Generated Noise in Excess of County Standards?

Onsite Solar and Battery Storage Facilities Construction Noise

Construction noise associated with the Proposed Project would be temporary and would vary depending on the nature of the activities being performed. Noise generated would primarily be associated with the operation of off-road equipment for onsite construction activities as well as construction vehicle traffic on area roadways. Construction noise typically occurs intermittently and varies depending on the nature or phase of construction (e.g., land clearing, grading, excavation, paving). Noise generated by construction equipment, including earth movers, pile drivers, and portable generators, can reach high levels. Typical operating cycles for these types of construction equipment may involve one or two minutes of full power operation followed by three to four minutes at lower power settings. Other primary sources of acoustical disturbance would be random incidents, which would last less than one minute (such as dropping large pieces of equipment or the hydraulic movement of machinery lifts). During construction, exterior noise levels could negatively affect sensitive land uses in the vicinity of the construction site.

The nearest existing noise-sensitive land use to the Project Site is a single-family residence located approximately 450 feet from the western boundary of the North Star 1 Project boundary. As previously described, the County's General Plan Noise Element states construction equipment operation shall be limited to the hours of 7:00 a.m. to 7:00 p.m., Monday through Friday, and 9:00 a.m. to 5:00 p.m. on Saturdays. No commercial construction operations are permitted on Sundays or holidays. Construction noise, from a single piece of equipment or a combination of equipment, shall not exceed 75 dB L_{eq} , when averaged over an eight-hour period, and measured at the nearest sensitive receptor. This standard, established by the County to prevent physical and mental damage consistent with exposure to excessive noise, assumes a construction period, relative to an individual sensitive receptor of days or weeks. In cases of extended length construction times, the standard may be tightened so as not to exceed 75 dB L_{eq} when averaged over a one-hour period.

The anticipated short-term construction noise levels generated for the necessary construction equipment during the onsite solar and battery storage facility component of the Proposed Project are presented in Table 6.

Table 6. Construction Average (dBA) Noise Levels at Nearest Receptor			
Equipment	Estimated Exterior Construction Noise Level at Existing Residences	Construction Noise Standards (dBA L_{eq})	Exceeds Standards?
Site Preparation			
Off-Highway Truck	53.4	75	No
Rubber Tired Dozers (2)	58.6 (each)	75	No
Tractors/Loaders/Backhoes (2)	60.9 (each)	75	No
Combined Site Preparation Equipment	66.2	75	No
Grading			
Excavators (4)	57.6 (each)	75	No
Graders (3)	61.9 (each)	75	No
Rubber Tired Dozers (2)	58.6 (each)	75	No
Scrapers (2)	60.5 (each)	75	No
Tractors/Loaders/Backhoes (4)	60.9 (each)	75	No
Combined Grading Equipment	72.0	75	No
Facility Construction			
Crane	53.5	75	No
Off-Highway Trucks (4)	53.4 (each)		
Paver	55.1	75	No
Paving Equipment (2)	63.4 (each)	75	No
Plate Compactors (4)	57.2 (each)	75	No
Rollers (2)	53.9 (each)	75	No
Rough Terrain Forklifts (4)	60.3 (each)	75	No
Tractors/Loaders/Backhoes (4)	60.9 (each)	75	No
Trenchers (2)	58.3 (each)		
Welder	50.9	75	No
Combined Construction, Trenching, & Paving	71.8	75	No

Source: Construction noise levels were calculated by ECORP Consulting using the FHWA Roadway Noise Construction Model (FHWA 2006). Refer to Attachment A for Model Data Outputs.

Notes: Construction equipment used during construction derived from the California Emission Estimator Model (CalEEMod) 2020.4.0. CalEEMod contains default construction equipment and usage parameters for typical construction projects based on several construction surveys conducted in order to identify such parameters. The nearest residence is located approximately 450 feet from the Project boundary.

L_{eq} = The equivalent energy noise level, is the average acoustic energy content of noise for a stated period of time. Thus, the L_{eq} of a time-varying noise and that of a steady noise are the same if they deliver the same acoustic energy to the ear during exposure. For evaluating community impacts, this rating scale does not vary, regardless of whether the noise occurs during the day or the night.

As shown in Table 6, no individual or cumulative pieces of construction equipment would exceed the 75 dBA County construction noise standard during any phase of construction at the nearby noise-sensitive receptors.

5.3.2 Would the Project Result in a Substantial Permanent Increase in Ambient Noise Levels in Excess of County Standards During Operations?

As previously described, noise-sensitive land uses are locations where people reside or where the presence of unwanted sound could adversely affect the use of the land. Residences, schools, hospitals, guest lodging, libraries, and some passive recreation areas would each be considered noise-sensitive and may warrant unique measures for protection from intruding noise. The nearest existing noise-sensitive land use to the Project Site is a single-family residence located approximately 450 feet from the western boundary of the North Star 1 Project boundary.

Operational Offsite Traffic Noise

Project operations would result in minimal additional traffic on adjacent roadways. The only visitors to the site would be that of water deliveries, repair or maintenance workers, whose presence at the site would be necessary infrequently and inconsistently. According to the California Department of Transportation (Caltrans) *Technical Noise Supplement to the Traffic Noise Analysis Protocol* (2013), doubling of traffic on a roadway is required to result in an increase of 3 dB (outside of the laboratory, a 3-dBA change is considered a just-perceivable difference). The Proposed Project would not result in a doubling of traffic on vicinity roadways, and therefore its contribution to existing traffic noise would not be perceptible.

Operational Onsite Noise

As previously stated, noise sensitive land uses are locations where people reside or where the presence of unwanted sound could adversely affect the use of the land. Residences, schools, hospitals, guest lodging, libraries, and some passive recreation areas would each be considered noise-sensitive and may warrant unique measures for protection from intruding noise. The nearest existing noise-sensitive land use to the Project Site is a single-family residence located approximately 450 feet from the western boundary of the North Star 1 Project boundary.

The main stationary operational noise associated with the Project would be from the proposed transformers, inverters, substation, and transmission lines. Project operations have been calculated using the SoundPLAN 3D noise model. As previously stated, a noise level of 47.1 dBA was employed as the reference noise level in the SoundPLAN 3D noise model to determine noise-level propagation associated with the Project operations. The results of this model can be found in Attachment B. Table 7 shows the predicted Project noise levels at the nearest noise-sensitive land uses in the Project vicinity, as predicted by SoundPLAN (Figure 4.)

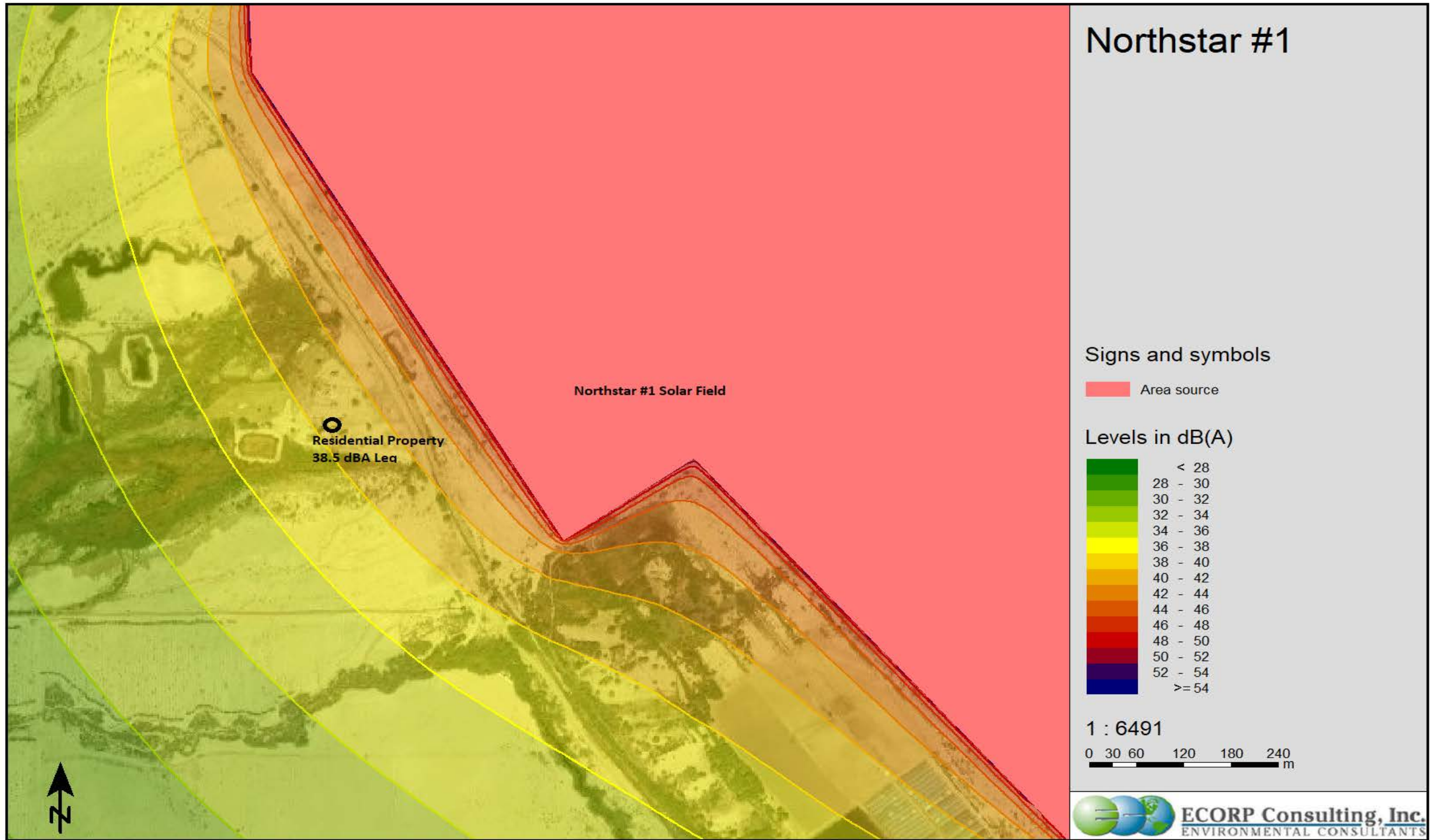

Map Date: 6/3/2022
 Photo (or Base) Source: SoundPLAN 5.1

Figure 4. Project Onsite Noise Source Propagation

Location	Modeled Operational Noise Attributed to Project (L_{eq} dBA)	County Daytime Standard (L_{eq} dB)	County Nighttime Standard (L_{eq} dB)	Exceed Standard?
Residence located west of Project Site, 450 feet from the western boundary	38.5	50.0	45.0	No

Source: Stationary source noise levels were modeled by ECORP using SoundPLAN 3D noise model. Refer to Attachment B for noise modeling assumptions and results.

Note: Reference noise measurement used to calculate Project onsite noise propagation identified at 47.1 dBA, per 30-minute measurements taken at a solar generation facility in Imperial County.

As shown in Table 7, Project operational noise would not exceed County daytime or nighttime standards.

5.3.3 Would the Project Expose Structures to Substantial Groundborne Vibration During Construction?

Excessive groundborne vibration impacts result from continuously occurring vibration levels. Increases in groundborne vibration levels attributable to the Project would be primarily associated with short-term construction-related activities. Construction on the Project Site would have the potential to result in varying degrees of temporary groundborne vibration, depending on the specific construction equipment used and the operations involved. Ground vibration generated by construction equipment spreads through the ground and diminishes in magnitude with increases in distance.

Construction-related ground vibration is normally associated with impact equipment such as pile drivers, jackhammers, and the operation of some heavy-duty construction equipment, such as dozers and trucks. Pile drivers would be necessary during Project construction. Vibration decreases rapidly with distance and construction activities would occur throughout the Project Site and would not be concentrated at the point closest to sensitive receptors. Groundborne vibration levels associated with typical construction equipment at 25 feet distant are summarized in Table 8.

Equipment Type	Peak Particle Velocity at 25 Feet (inches per second)
Large Bulldozer	0.089
Pile Driver	0.170
Loaded Trucks	0.076
Hoe Ram	0.089
Jackhammer	0.035
Small Bulldozer/Tractor	0.003
Vibratory Roller	0.210

Source: FTA 2018; Caltrans 2020b

The County of Imperial does not regulate vibrations associated with construction. However, a discussion of construction vibration is included for full disclosure purposes. For comparison purposes, the Caltrans (2020b) recommended standard of 0.2 inch per second PPV with respect to the prevention of structural damage for older residential buildings is used as a threshold. This is also the level at which vibrations may begin to annoy people in buildings. Consistent with FTA recommendations for calculating construction vibration, construction vibration was measured from the center of the Project Site (FTA 2018). The nearest structure of concern to the construction site, with regard to groundborne vibrations, are solar panels located approximately 350 feet below the Project Site.

Based on the representative vibration levels presented for various construction equipment types in Table 8 and the construction vibration assessment methodology published by the FTA (2018), it is possible to estimate the potential project construction vibration levels. The FTA provides the following equation:

$$[PPV_{\text{equip}} = PPV_{\text{ref}} \times (25/D)^{1.5}]$$

Table 9 presents the expected Project related vibration levels at a distance of 350 feet.

Table 9. Construction Vibration Levels at 350 Feet							
Receiver PPV Levels (in/sec)¹					Peak Vibration	Threshold	Exceed Threshold
Large Bulldozer, Caisson Drilling, & Hoe Ram	Loaded Trucks	Jackhammer	Pile Driver	Vibratory Roller			
0.002	0.002	0.001	0.003	0.004	0.004	0.2	No

Notes: ¹Based on the Vibration Source Levels of Construction Equipment included on Table 8 (FTA 2018). Distance to the nearest structure of concern is approximately 350 feet measured from Project Site boundary.

As shown in Table 9, vibration as a result of construction activities would not exceed 0.2 PPV at the nearest structure. Thus, project construction would not exceed the recommended threshold.

5.3.4 Would the Project Expose Structures to Substantial Groundborne Vibration During Operations?

Project operations would not include the use of any large-scale stationary equipment that would result in excessive vibration levels. Therefore, the project would not result groundborne vibration impacts during operations.

5.3.5 Would the Project Expose People Residing or Working in the Project area to Excessive Airport Noise?

The Project Site is located approximately 38 miles north of the El Centro Airport in El Centro and 15 miles north of the Calipatria Municipal Airport in Calipatria. The Imperial County Airport Land Use Commission

has established a set of land use compatibility criteria for lands surrounding the airports in Imperial County in the Imperial County Airport Land Use Compatibility Plan (1996). As identified in the Imperial County Airport Land Use Compatibility Maps, the Proposed Project Site lays outside of the noise contours of all airports. Therefore, the Project would not expose Project workers to excessive airport noise.

5.3.6 Cumulative Noise

5.3.6.1 *Would the Project Contribute to Cumulatively Considerable Noise During Construction?*

Construction activities associated with the Proposed Project and other construction projects in the area may overlap, resulting in construction noise in the area. However, construction noise impacts primarily affect the areas adjacent to the construction site. Construction noise for the Project was determined to be less than significant following compliance with County noise standards. Cumulative development in the vicinity of the Project Site could result in elevated construction noise levels at sensitive receptors in the Project vicinity. However, each project would be required to comply with the applicable noise limitations on construction. Therefore, the Project would not contribute to cumulative impacts during construction.

5.3.6.2 *Would the Project Contribute to Cumulatively Considerable Noise from Offsite Traffic?*

As described previously, Project operations would result in extremely minimal additional traffic on adjacent roadways. The only visitors to the site would be that of water deliveries, repair or maintenance work that would be done infrequently. Thus, any cumulative noise impacts from project-related traffic would be minimal. Therefore, the Project's contribution to cumulative noise impacts from traffic would be less than significant.

5.3.6.3 *Would the Project Contribute to Cumulatively Considerable Noise from Stationary Sources?*

Cumulative noise impacts would primarily be associated with the transformers, inverters, substation, and transmission lines from the solar facility. Long-term noise sources associated with development at the Project, combined with other cumulative projects, could cause local noise-level increases. Noise levels associated with the Proposed Project and related cumulative projects together could result in higher noise levels than considered separately. However, noise increase as a result of the Project would not be perceivable and would not exceed County standards.

6.0 REFERENCES

- California Department of Transportation (Caltrans). 2020a. IS/EA Annotated Outline.
<http://www.dot.ca.gov/ser/vol1/sec4/ch31ea/chap31ea.htm>.
- _____. 2020b. Transportation and Construction Vibration Guidance Manual.
- _____. 2018. Traffic Census Program: 2017 Traffic Volumes. <https://dot.ca.gov/programs/traffic-operations/census>
- _____. 2013. Technical Noise Supplement to the Traffic Noise Analysis Protocol.
- County of Imperial. 2015. General Plan Noise Element.
- _____. 2008. General Plan Circulation and Scenic Highways Element.
- _____. 1996. Imperial County Airport Land Use Compatibility Plan.
- Federal Highway Administration (FHWA). 2017. *Construction Noise Handbook*.
https://www.fhwa.dot.gov/Environment/noise/construction_noise/handbook/handbook02.cfm.
- _____. 2011. Effective Noise Control During Nighttime Construction. Available online at:
http://ops.fhwa.dot.gov/wz/workshops/accessible/schexnayder_paper.htm.
- _____. 2006. Roadway Construction Noise Model.
- Federal Transit Administration (FTA). 2018. Transit Noise and Vibration Impact Assessment.
- Harris Miller, Miller & Hanson Inc. 2006. Transit Noise and Vibration Impact Assessment, Final Report.
- Office of Planning and Research(OPR). 2003. State of California General Plan Guidelines.
- Western Electro-Acoustic Laboratory, Inc. 2000. Sound Transmission Sound Test Laboratory Report No. TL 96-186.

LIST OF APPENDICES

Appendix A - Federal Highway Administration Highway Roadway Construction Noise Outputs –
Project Construction Noise

Appendix B – SoundPLAN 3-D Noise Model Outputs – Project Onsite Noise

APPENDIX A

Federal Highway Administration Highway Roadway Construction Noise Outputs – Project
Construction Noise

Roadway Construction Noise Model (RCNM), Version 1.1

Report date: 5/27/2022
 Case Description: **Site Preparation**

Description **Land Use**
 Site Preparation Residential

Description	Impact Device	Usage(%)	Equipment		Receptor Distance (feet)
			Spec Lmax (dBA)	Actual Lmax (dBA)	
Dump Truck	No	40		76.5	450
Dozer	No	40		81.7	450
Dozer	No	40		81.7	450
Tractor	No	40	84		450
Tractor	No	40	84		450

Results

Calculated (dBA)

Equipment	*Lmax	Leq
Dump Truck	57.4	53.4
Dozer	62.6	58.6
Dozer	62.6	58.6
Tractor	64.9	60.9
Tractor	64.9	60.9
Total	64.9	66.2

*Calculated Lmax is the Loudest value.

Roadway Construction Noise Model (RCNM),Version 1.1

Report date: 5/27/2022
 Case Description: Grading

Description **Land Use**
 Grading Residential

Description	Impact Device	Usage(%)	Equipment		Receptor Distance (feet)
			Spec Lmax (dBA)	Actual Lmax (dBA)	
Excavator	No	40		80.7	450
Excavator	No	40		80.7	450
Excavator	No	40		80.7	450
Excavator	No	40		80.7	450
Grader	No	40	85		450
Grader	No	40	85		450
Grader	No	40	85		450
Dozer	No	40		81.7	450
Dozer	No	40		81.7	450
Scraper	No	40		83.6	450
Scraper	No	40		83.6	450
Tractor	No	40	84		450
Tractor	No	40	84		450
Tractor	No	40	84		450
Tractor	No	40	84		450

Results

Calculated (dBA)

Equipment	*Lmax	Leq
Excavator	61.6	57.6
Excavator	61.6	57.6
Excavator	61.6	57.6
Excavator	61.6	57.6
Grader	65.9	61.9
Grader	65.9	61.9
Grader	65.9	61.9
Dozer	62.6	58.6
Dozer	62.6	58.6
Scraper	64.5	60.5
Scraper	64.5	60.5
Tractor	64.9	60.9
Tractor	64.9	60.9

Tractor		64.9	60.9
Tractor		64.9	60.9
	Total	65.9	72

*Calculated Lmax is the Loudest value.

Roadway Construction Noise Model (RCNM),V

Report date: 5/27/2022
 Case Description: Facility Construction

Description **Land Use**
 Facility Construction Residential

Description	Impact Device	Usage(%)	Equipment		Receptor Distance (feet)
			Spec Lmax (dBA)	Actual Lmax (dBA)	
Crane	No	16		80.6	450
Dump Truck	No	40		76.5	450
Dump Truck	No	40		76.5	450
Dump Truck	No	40		76.5	450
Dump Truck	No	40		76.5	450
Paver	No	50		77.2	450
Pavement Scarafier	No	20		89.5	450
Pavement Scarafier	No	20		89.5	450
Compactor (ground)	No	20		83.2	450
Compactor (ground)	No	20		83.2	450
Compactor (ground)	No	20		83.2	450
Compactor (ground)	No	20		83.2	450
Roller	No	20		80	450
Roller	No	20		80	450
Gradall	No	40		83.4	450
Gradall	No	40		83.4	450
Gradall	No	40		83.4	450
Gradall	No	40		83.4	450
Tractor	No	40	84		450
Tractor	No	40	84		450

Results

Calculated (dBA)

Equipment	*Lmax	Leq
Crane	61.5	53.5
Dump Truck	57.4	53.4
Dump Truck	57.4	53.4
Dump Truck	57.4	53.4
Dump Truck	57.4	53.4
Paver	58.1	55.1
Pavement Scarafier	70.4	63.4
Pavement Scarafier	70.4	63.4

Compactor (ground)	64.1	57.2
Compactor (ground)	64.1	57.2
Compactor (ground)	64.1	57.2
Compactor (ground)	64.1	57.2
Roller	60.9	53.9
Roller	60.9	53.9
Gradall	64.3	60.3
Gradall	64.3	60.3
Gradall	64.3	60.3
Gradall	64.3	60.3
Tractor	64.9	60.9
Tractor	64.9	60.9
Total	70.4	71.8

*Calculated Lmax is the Loudest value.

Roadway Construction Noise Model (RCNM),V

Report date: 5/27/2022
 Case Description: Facility Construction cont'd

Description **Land Use**
 Facility Construction Residential

Description	Impact Device	Usage(%)	Equipment		Receptor Distance (feet)
			Spec Lmax (dBA)	Actual Lmax (dBA)	
Tractor	No	40	84		450
Tractor	No	40	84		450
Slurry Trenching Machine	No	50		80.4	450
Slurry Trenching Machine	No	50		80.4	450
Welder / Torch	No	40		74	450

Results

Calculated (dBA)

Equipment	*Lmax	Leq
Tractor	64.9	60.9
Tractor	64.9	60.9
Slurry Trenching Machine	61.3	58.3
Slurry Trenching Machine	61.3	58.3
Welder / Torch	54.9	50.9
Total	64.9	66

*Calculated Lmax is the Loudest value.

SoundPLAN Outputs – Onsite Project Noise

SoundPLAN
Output Source Information

Number	Receiver Name	Floor	Level at Receiver
1	Residence Located West of Project Site	Ground Floor	38.5 dBA

Number	Noise Source Information	Citation	Level at Source
1	Project Site Solar Facility	ECORP reference measurement	47.1 @ Source

Visual Resources Impact Assessment for the North Star 1 Project

Imperial County, California

Prepared For:

ZGlobal, Inc.
604 Sutter Street, Suite 250
Folsom, California 95630

Prepared By:



ECORP Consulting, Inc.
ENVIRONMENTAL CONSULTANTS

2525 Warren Drive
Rocklin, California 95677

March 14, 2023

CONTENTS

1.0 INTRODUCTION 1

2.0 AFFECTED ENVIRONMENT..... 2

 2.1 Regulatory Framework..... 2

 2.1.1 Federal 2

 2.1.2 State..... 6

 2.1.3 Local..... 6

 2.2 Regional Setting 8

 2.3 Existing Visual Character of the Project Area..... 8

 2.4 Local Character..... 9

 2.4.1 Scenic Highways 9

 2.4.2 Scenic Vistas 9

 2.4.3 Principal Viewpoints..... 9

 2.5 KOP Identification 9

3.0 METHODOLOGY..... 10

 3.1 Introduction..... 10

 3.2 Visual Character 10

 3.3 Viewer Sensitivity 10

 3.4 Contrast Rating 11

 3.5 Solar Panel Glare Potential 12

4.0 IMPACT ASSESSMENT 13

 4.1 Thresholds of Significance..... 13

 4.2 Contrast Rating Analysis..... 14

 4.3 Solar Glare Analysis 15

 4.4 Impact Analysis 15

 4.5 Mitigation Measures 16

5.0 REFERENCES..... 17

LIST OF TABLES

Table 1. Project Consistency with the Conservation and Open Space, Land Use and Circulation & Scenic Highways..... 7

LIST OF FIGURES

Figure 1. Project and KOP Location.....3
Figure 2. View from KOP 1.....4
Figure 3. Viewshed Analysis5

APPENDICES

- Appendix A – Contrast Rating Worksheets
- Appendix B – Glare Analysis Report

LIST OF ACRONYMS AND ABBREVIATIONS

Term	Definition
APN	Assessor’s Parcel Number
BESS	Battery Electric Storage System
BLM	Bureau of Land Management
Caltrans	California Department of Transportation
County	Imperial County
CUP	Conditional Use Permit
DOC	Department of Conservation
FAA	Federal Aviation Administration
KOP	Key Observation Point
MW	Megawatt
msl	Mean Sea Level
PG&E	Pacific Gas & Electric Company
PV	Photovoltaic
Project	North Star 1 Solar Energy System and Battery Electric Storage System
RE Overlay Zone	County’s Renewable Energy and Transmission Element
SES	Solar Energy System

1.0 INTRODUCTION

ZGlobal, Inc., through its wholly owned subsidiary North Star 1 SES, LLC (Applicant), is proposing development of the North Star 1 Solar Energy System (SES) and Battery Electric Storage System (BESS, Project), approximately 7 miles north of the community of Niland, California in Imperial County (County), California. ECORP Consulting, Inc. has been contracted to assess potential impacts to aesthetics and visual resources from construction and operation of the Proposed Project, assess potential glare-related safety hazards, and document the results of both efforts in this report. This Visual Resources Impact Assessment discusses existing conditions on the Proposed Project site, applicable regulations, potential impacts, and the need for mitigation measures to reduce or avoid adverse impacts anticipated from implementation of the Proposed Project, as applicable. The glare hazard analysis consists of identifying locations that could experience glare conditions during Project operations using a computer model and assessing the potential severity of the hazard.

The Proposed Project includes a 50-megawatt (MW) solar field, consisting of solar photovoltaic (PV) modules mounted on Horizontal Single-Axis Tracker systems with mounting racks supported by driven piles, and a 75-MW BESS. The solar field consists of 110,250 modules on 3,675 strings and associated collector and inverter facilities. It would connect offsite to the Pacific Gas & Electric Company (PG&E) grid through a gen-tie line to PG&E's 161 kilovolts N transmission line near the Coachella Canal. The projected lifespan of the Proposed Project is 20 years. The Project Area will be restored to pre-Project conditions following decommissioning.

The Proposed Project site is in a remote area (Figure 1). It is located on approximately 288 acres of vacant land on two parcels in Imperial County, California (Assessor's Parcel Number [APN] 003-110-005, and 003-110-007, 112, and 176 acres, respectively). Agricultural production is the primary human use near the Proposed Project. The site is currently vacant undeveloped land. It is surrounded by Open Space to the north, east, and west and active agriculture is to the south.

The site is within an Imperial County General Plan-designated Agricultural area and is zoned S-2 (Open Space/Preservation), which allows solar generating facilities with a Conditional Use Permit (CUP). The California Department of Conservation's (DOC) Imperial County Important Farmland Map categorizes the parcels, for the Proposed Project, as *Other Land*, indicating that they are not considered important farmland under any category, which includes Prime Farmland, Farmland of Statewide Importance, Unique Farmland, and Farmland of Local Importance (DOC 2018).

Parcel 110-005 is located within the County's Renewable Energy and Transmission Element (RE Overlay Zone). Parcel 110-007 is not located within the RE Overlay Zone (Imperial County 2015a). An amendment to the County's General Plan is needed to include the entire Proposed Project site within the RE Overlay Zone, and a CUP is needed to allow construction and operation of the Project within the RE Overlay Zone.

The Proposed Project site, at an elevation range of approximately 60 feet below Mean Sea Level (msl) to 15 feet above msl, consists of vacant, undeveloped Sonoran Desert scrub. The vicinity of the Proposed Project Area is characterized by open and vast views with flat to undulating topography. There is a mixed semi-desert landscape to the north, east, and west. There are smooth dirt and soft sand dunes that lead to

distant mountain forms to the north and east. Agricultural croplands dominate the landscape to the south. Vegetation in the geometric agricultural fields is defined by distinct edges of exposed soils, with consistent groupings of bright yellow to dark green colors and a smooth, carpet-like texture.

Highway 111 is approximately 2.6 miles to the west. Local unpaved roads provide access to the Proposed Project Site from Highway 111. The Union Pacific Railroad is located immediately to the east of Highway 111. The Salton Sea is approximately 3.25 miles west of the Proposed Project. The East Highline Canal is just west of the site. Approximately 1 mile to the east of the Proposed Project site are Coachella Canal Road, the Coachella Canal and Gas Line Road. The Coachella Canal is a 122-mile aqueduct that conveys Colorado River water from the All-American Canal, through the Imperial Valley, to the Coachella Valley for irrigation purposes. Both the Highline and Coachella canals are used only for irrigation.

The overall character of the immediate landscape is natural open space to the north, west and east and agricultural to the south. The most notable natural features in the landscape are the ranges in the background to the north and east of the Proposed Project site (Chocolate Mountains). The dark grey, subdued formations of the Chocolate Mountains, approximately 2.5 miles to the east of the Proposed Project Site, are approximately 2,000 feet above msl and are visible along the horizon from the site. Agricultural development to the south of the Proposed Project largely contributes to the human-made changes in the natural landscape. Rural residences and agricultural structures, located on subdivided land, are scattered throughout the area. The existing human-made features in the landscape are primarily geometric-shape. Transmission lines run throughout the general area and consist of vertical, continuous, galvanized, grey to silver (metallic) conductors and light brown to dark brown (wood) poles or metallic lattice structures. There is a network of light tan to dark tan, dirt access roads throughout the general area. The roads can contribute contrast with the existing agricultural fields, during the active agricultural season. Figures 1, 2 and 3 show Project and Key Observation Point (KOP) locations, view from KOP 1, and viewshed analysis, respectively.

2.0 AFFECTED ENVIRONMENT

2.1 Regulatory Framework

2.1.1 Federal

There are no federal laws or regulations that apply to this Visual Resources Impact Assessment, though it includes an analysis following the Bureau of Land Management (BLM) Visual Resources Inventory class system to describe the existing scenic values in the environment. The BLM's process is often applied to non-BLM visual assessments to provide Project proponents and authorizing agencies a consistent and translatable methodology for understanding visual impacts from proposed projects.

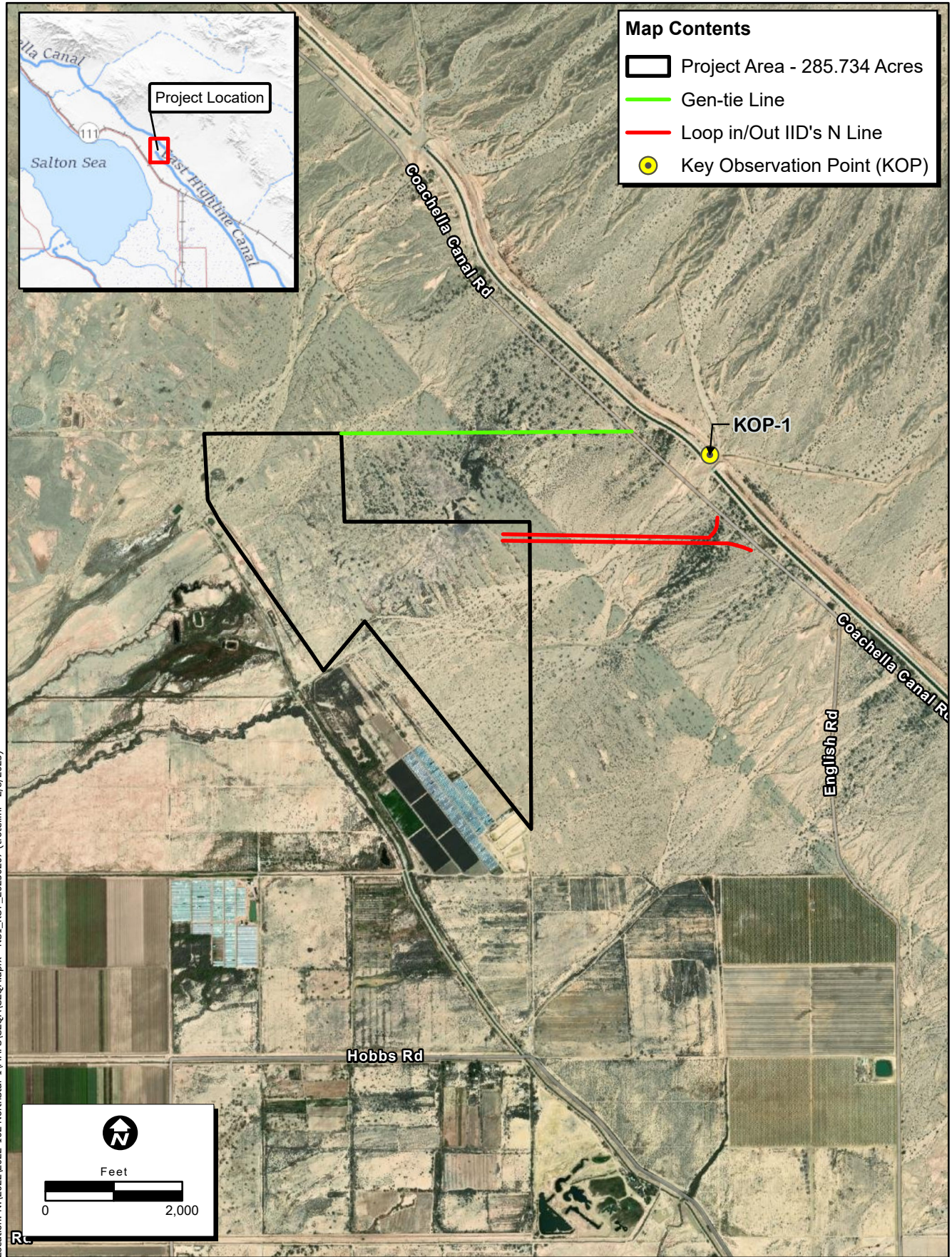

Figure 1. Project and KOP Location



ECORP Consulting, Inc.
ENVIRONMENTAL CONSULTANTS

Figure 2. View from KOP 1

2022-102/NorthStar 1

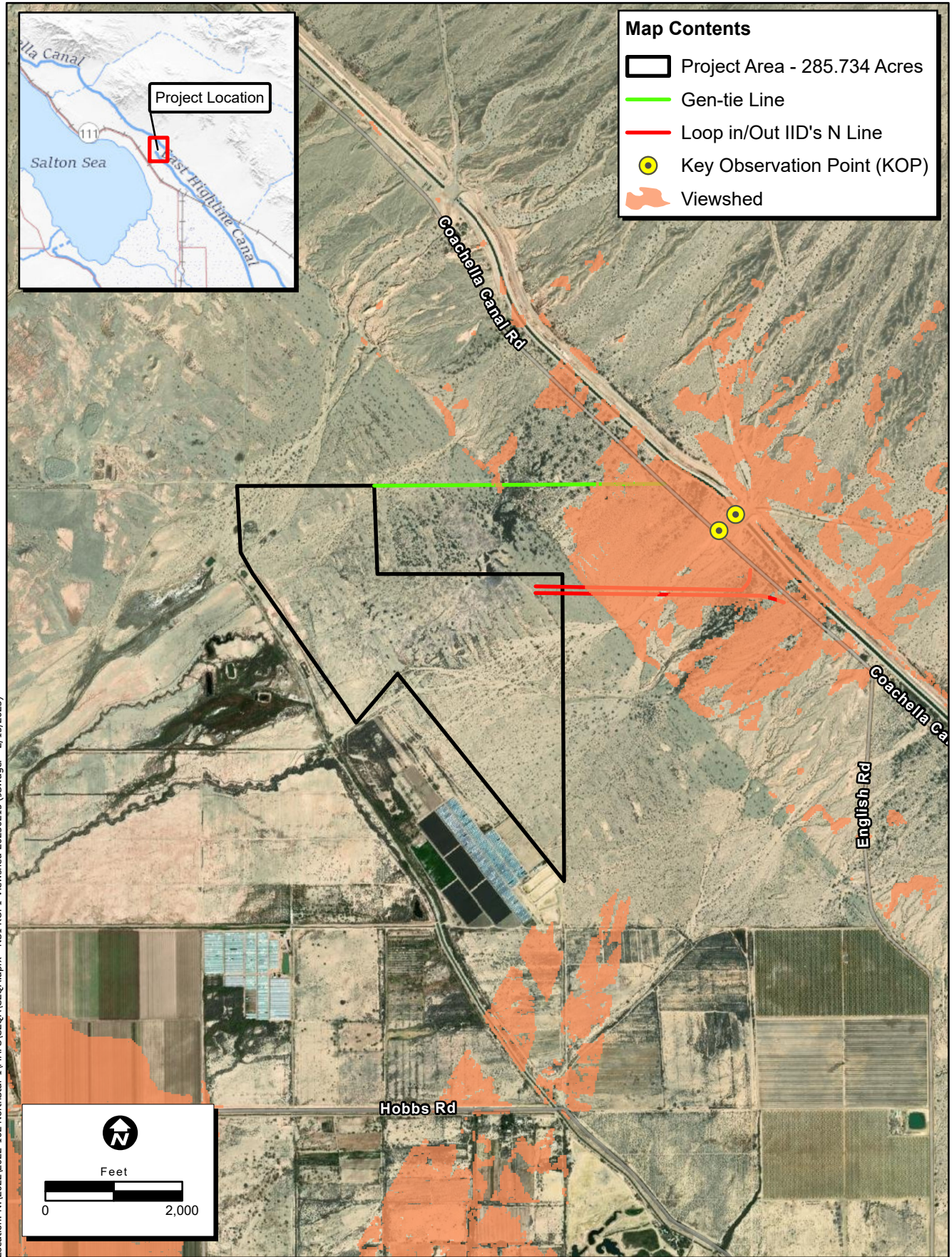

Figure 3. Viewshed Analysis

Visual resource inventory classes are assigned through the inventory process, based on several factors including type of users, amount of use, public interest, adjacent land uses, special areas, and other factors. Classes I and II are assigned to most valued resources, with Class I reserved for those areas where a management decision has been made previously to maintain a natural landscape. This includes areas such as national wilderness areas, the wild section of national wild and scenic rivers, and other congressionally and administratively designated areas where decisions have been made to preserve a natural landscape. Classes II, III, and IV are assigned based on a combination of scenic quality, sensitivity level, and distance zones. This is accomplished by combining the three overlays for scenic quality, sensitivity levels, and distance zones, and using the guidelines to assign the proper class. Class III represents a moderate value, and Class IV is of least value. Inventory classes are informational in nature and provide the basis for considering visual values in the Resource Management Plan process. They do not establish management direction and should not be used as a basis for constraining or limiting surface disturbing activities.

2.1.2 State

The California Department of Transportation (Caltrans) manages the California Scenic Highway Program. The goal of the program is to preserve and protect scenic highway corridors from changes that would affect the aesthetic value of the land adjacent to the scenic corridor.

2.1.3 Local

The Proposed Project site is under the Imperial County jurisdiction and subject to the County Development Code and General Plan guidelines. Section 92407.01 of the Development Code includes development criteria for facilities located within 0.5 mile of a designated scenic highway. There are no designated scenic highways within 0.5 mile of the Proposed Project Site.

The County General Plan does not specifically contain a visual element; however, it addresses related topics in the following General Plan Sections:

- Land Use Element;
- Circulation & Scenic Highways Element;
- Conservation and Open Space Element; and
- Renewable Energy and Transmission Element.

In addition, the Renewable Energy and Transmission Element (Imperial County 2015a) includes specific goals, policies, and standards for renewable energy and, specifically, solar projects. Table 1 provides an analysis of the Proposed Project's consistency with the Conservation and Open Space, Land Use, and Circulation & Scenic Highway elements (Imperial County 2015b).

Table 1. Project Consistency with the Conservation and Open Space, Land Use and Circulation & Scenic Highways		
General Plan Policies	Consistency with General Plan	Analysis
Conservation and Open Space Element		
Goal 5: The aesthetic character of the region shall be protected and enhanced to provide a pleasing environment for residential, commercial, recreational, and tourist activity.	Yes	The Proposed Project would result in changes to the visual character of the Project Site, which is currently characterized as desert landscape. However, the Project Site does not contain high levels of visual character or quality, and the Project will be screened with a fence designed to blend with the landscape; therefore, the Proposed Project would not result in a significant deterioration in the visual character of the Proposed Project Site or Project vicinity.
Objective 5.1: Encourage the preservation and enhancement of the natural beauty of the desert and mountain landscape.	Yes	See discussion regarding Goal 5.
Goal 7: The aesthetic character of the region shall be protected and enhanced to provide a pleasing environment for residential, commercial, recreational, and tourist activity.	Yes	See discussion regarding Goal 5. There is no residential or commercial development near the Proposed Project, and the Project Area is not used for recreational activities.
Land Use Element		
Goal 3: Achieve balanced economic and residential growth while preserving the unique natural, scenic, and agricultural resources of Imperial County.	Yes	See discussion regarding Objective 4.3.
Objective 3.4: Protect/improve the aesthetics of Imperial County and its communities.	Yes	The Proposed Project would result in changes to the visual character of the Project Site, which is currently characterized as a desert landscape. The Project Site does not contain high levels of visual character or quality, and the Project will be screened with a fence designed to blend with the landscape; therefore, the Project would not result in a significant deterioration in the visual character of the Project Site or vicinity.
Circulation and Scenic Highways Element		
Objective 4.3: Protect areas of outstanding scenic beauty along any scenic highways and protect the aesthetics of those areas.	Yes	The Proposed Project is not sited in the vicinity of a designated scenic highway.

Table 1. Project Consistency with the Conservation and Open Space, Land Use and Circulation & Scenic Highways		
General Plan Policies	Consistency with General Plan	Analysis
Objective 4.5: Develop standards for aesthetically valuable sites. Design review may be required so that structures, facilities, and activities are properly merged with the surrounding environment.	Yes	The Project has been designed to avoid impacts to scenic resources.
Policy 9 (b): The County shall emphasize protection of scenic highway resources in all County actions affecting land use.	Yes	There are no scenic highways in the Project vicinity.

Source: Imperial County General Plan (2015).

2.2 Regional Setting

The Proposed Project Site is located approximately 7 miles north of the community of Niland, California in Imperial County, California. It is approximately 2.5 miles east of Highway 111 and 0.5 mile west of Coachella Canal and Gas Line roads. Local unpaved roads provide access to the Proposed Project site from Highway 111. The Union Pacific Railroad is located immediately to the east of Highway 111. The Salton Sea is approximately 3.25 miles west of the Proposed Project. The Coachella Canal is a 122-mile aqueduct that conveys Colorado River water from the All-American Canal, through the Imperial Valley, to the Coachella Valley for irrigation purposes. The East Highline Canal is just west of the site. Both the Coachella and Highline canals are used only for irrigation.

2.3 Existing Visual Character of the Project Area

The overall character of the immediate landscape is agricultural to the south and natural open space to the north, east, and south. Agricultural areas include rectangular fields and associated structures and ponds and canals. Paved and dirt roads run throughout the Project Area. Transmission lines (i.e., wood poles) are found to the west and south of the site. High-power transmission lines (steel towers/poles) are located just to the west of the Coachella Canal Road, Coachella Canal, and Gas Line Road (approximately 0.5 mile east of the Proposed Project Site).

The Proposed Project vicinity is characterized by open and vast views with flat to undulating topography. There is desert landscape to the north, east, and west; smooth dirt and soft sand dunes that lead to distant mountain form to the north and east; and agricultural cropland dominates the landscape to the south. The most notable natural features in the landscape are the textured dirt and sand with sparse desert vegetation on the foreground, and soft, light tan, scenic sand dunes leading to mountain ranges in the background. The dark gray, subdued formations of the Chocolate Mountains approximately 6 miles to the east of the Proposed Project vicinity are approximately 2,000 feet above msl and are visible along the horizon. The Salton Sea is approximately 3 miles to the west of the Project Site.

Vegetation in the geometric agricultural fields is defined by distinct edges of exposed soils, with consistent groupings of bright yellow to dark green colors and a smooth, carpet-like texture. The vegetation to the north, east, and west is consistent and includes low-profile desert shrubs that are light khaki to dark brown.

The existing natural landscape is a valued resource because of its unspoiled nature and panoramic view, especially of the mountains and dunes in the background, which can be seen by motorists along local roads and agricultural workers in the vicinity. The foreground view (Figure 3), consisting of comparatively monotonous desert scrub habitat, is less valued because of the lack of distinguishing or interesting features, as evidenced by the lack of turnouts allowing motorists to stop and enjoy the view at the Proposed Project site. Though not on federal land, the Project Site would be given a Class III designation under the BLM's Visual Resources Inventory classification system, representing an overall moderate value.

2.4 Local Character

2.4.1 Scenic Highways

There are no state-designated or eligible scenic highways in the vicinity of the Project Site. Highway 111 is not a scenic route according to the List of Officially Designated State Scenic Highways from Caltrans (2023).

2.4.2 Scenic Vistas

There are neither Caltrans-designated vista points in the Project vicinity, nor any formal or informal turnouts along the highway near the Project Site.

2.4.3 Principal Viewpoints

There are no established viewpoints in the Proposed Project vicinity.

2.5 KOP Identification

The analysis identified KOP, KOP 1, along travel routes or other surrounding areas within approximately 1 mile of the Proposed Project, where views of the site are available (Figure 1). Figure 2 is a photograph showing the view from KOP 1, west toward the Project location.

The KOP is:

KOP 1: **“Siphon 13”:** A low bridge over the Coachella Canal connecting Coachella Canal Road (to the west of Siphon 13) with Gas Line Road (to the east of Siphon 13). It is approximately 0.5 mile from the Proposed Project Area. It represents the view for local road travelers east of the Proposed Project area. The Proposed Project gen-tie line connecting the Project to an existing PG&E transmission adjacent to Coachella Canal would be perceivable from this KOP based on viewer perspective, though other Project components, including the solar fields and BESS structures would not be visible from KOP 1 due to topography (Figure 3). The gen-tie would be similar in form, line, color, and texture to the existing transmission lines along

the canal. The Proposed Project site would be surrounded by a 6-foot chain link fence with light-colored slats, which would block direct view of the site. The color of the fence slats would provide minimal contrast with the existing, surrounding landscape.

No other KOPs were identified because the Project Site in general is not visible from any nearby location where people could see Project components, as verified during site visits in the area and with viewshed analysis software.

3.0 METHODOLOGY

3.1 Introduction

The process of visual resource assessment provides a means for determining visual values and the possible effects of a proposed project on sensitive receptors (e.g., nearby residents, drivers and passengers, and pilots) from a KOP. This assessment is made based on various factors, including how a proposed project will impact adjacent land uses, public interest, and amount and type of use.

ECORP's assessments of existing visual conditions are based on professional judgment. As discussed in Section 2.5, the analysis identified one KOP, KOP 1 (Figures 1 and 2). Aerial images and photographs were used to document and understand the existing landscape character and compare that with the Proposed Project. A modified version of BLM's contrast rating worksheet (Form 8400-4) was used to determine the contrast rating for the Proposed Project. ECORP conducted a glare analysis to determine the potential for significant glint or glare from solar panels and other built-Project components that may affect residents, motorists, or airborne travelers.

3.2 Visual Character

A visual resources impact assessment is a process for describing the visual character of a project, determining the visibility of the project in the surrounding landscape, and describing the visual magnitude of the project when seen from various viewpoints. The process may include an evaluation of the visual contrast to a project within the existing landscape. Although it is a relatively straightforward and objective process, there may be differences in judgement. The process for assessing visual impacts is different than assigning social values to people and places affected by those visual impacts. For example, though people may agree that views within a designated national park must be protected, and a view of an active landfill does not, there is no objective process for making this determination (Palmer 2019).

3.3 Viewer Sensitivity

The consideration of viewer sensitivity is a critical component when assessing impact to visual resources. Both the BLM and the U.S. Forest Service conduct inventories on federal land when identifying visual resources, preparing visual resource management plans, and determining acceptable levels of change to visual impact. To determine sensitivity levels, the agencies consider objective factors such as amount of use, designation as a special area, and demonstrated public interest. In particular, the degree of public

importance placed on landscapes viewed from travel ways and use areas are measures used to determine levels of concern.

Visual sensitivity varies with the types of users. Visual receptors most sensitive to change usually include residents at home, those engaged in outdoor recreation, or residents or visitors using public rights-of-ways where interest is focused on particular landscapes or views. Workers passing through an area on a regular basis may not be as sensitive to change compared to recreational sightseers who may be highly sensitive. Visual receptors less sensitive to change include, for example, people at their place of work where the setting is not important to the quality of working life, or people engaged in travel, recreational, or sporting activities where appreciation of landscape views is not involved. Travelers on roads usually fall into an intermediate category of moderate sensitivity to change. However, where travel involves recognized scenic routes, such as those through national parks or monuments, awareness of viewers is likely particularly high (Palmer 2019). Additional detail is provided in Section 2.1.1.

Other than the Project gen-tie line, the Proposed Project is not located on federal land. However, it has been applied to this assessment for all Project components because the process described above has become an industry standard.

A viewshed analysis is a computational delineation that identifies the visible terrain from a given location. The analysis conducted for the Proposed Project shows that, except for the transmission gen-tie line, the Project is not visible from KOP 1. Therefore, the impact assessment (Section 4.0) is based on the impact created by the transmission gen-tie line instead of the entire Proposed Project.

3.4 Contrast Rating

Contrast is the difference in form, color, and light between elements and can be used to determine the degree to which a project or activity affects the visual quality of a landscape, depending on the visual contrasts created. Changes in contrast can affect viewer sensitivity. A higher degree of contrast creates a greater visual impact.

The federal BLM developed a contrast rating system for federal lands, which has become an industry standard. The rating system includes an analysis of the potential visual impact of a proposed project compared to the existing environmental setting as seen from a KOP. To properly assess the contrasts between the proposed and existing situation, it is necessary to break each down into basic features and elements, allowing for accurate identification of proposed features that may cause contrast (BLM 1986).

Features include:

- Landform/Water Features (e.g., roads, mining, gravel pits, landfills, water impoundments)
- Vegetative Features (e.g., timber harvests, grazing systems, vegetative manipulations)
- Structural Features (e.g., transmission lines, generation plants, oil and gas developments, recreation facilities, water tanks, buildings)
- Degrees of contrast criteria, for elements, include:

- None: The element contrast is not visible or perceived.
- Weak: The element contrast can be seen but does not attract attention.
- Moderate: The element contrast begins to attract attention and begins to dominate the characteristic landscape.
- Strong: If the element contrast demands attention, will not be overlooked, and is dominant in the landscape.

Assessing contrast also includes consideration of the following:

- Form: Contrast in form results from changes in the shape and mass of landforms or structures. The degree of change depends on how dissimilar the introduced forms are to those continuing to exist in the landscape.
- Line: Contrasts in line results from changes in edge types and interruption or introduction of edges, bands, and silhouette lines. New lines may differ in their sub-elements (i.e., boldness, complexity, and orientation) from existing lines.
- Color: Changes in value and hue tend to create the greatest contrast. Other factors such as chroma, reflectivity, color temperature, also increase the contrast.
- Texture. Noticeable contrast in texture usually stems from differences in the grain, density, and internal contrast. Other factors such as irregularity and directional patterns of texture may affect the rating.

The following distances zones were used for evaluating impact on the existing setting from KOPs:

- Foreground – up to 0.5 mile
- Midground – 0.5 to 3 miles
- Background – 3 to 5 miles

3.5 Solar Panel Glare Potential

Glint and glare are unwanted reflections of the sun's rays from a reflective surface. This can present a nuisance and, under some circumstances, a safety hazard. Therefore, solar developments can receive objections due to potential impacts caused by glint and glare. The Federal Aviation Administration (FAA) defines glint as a momentary flash of light and can be experienced by an observer passing a solar panel such as a motorist, and glare as a continuous source of excessive brightness that can be experienced by a stationary observer located in the path of reflected sunlight from the face of a solar panel (FAA 2022).

Glare can be hazardous for motorist, pilots, and other observers as a continuous source of excessive brightness. When light reflects off a surface, it can become polarized and produce a blinding glare or less severe effects such as ocular after-imaging. While all types of solar panels can cause solar glare, the intensity and duration depend on the design. Smooth glass solar panels and light-textured panels cause

the most intense glare while deeply textured panels (e.g., matted, non-reflective) has less intense glare but can cause glare for longer periods.

A solar panel comprises numerous solar cells. A solar cell differs from a typical reflective surface in that its surface is microscopically irregular and designed to trap the rays of sunlight for the purposes of energy production. The intent of solar technology is to increase efficiency by absorbing as much light as possible, which further reduces reflection and glare. A common misconception about solar PV panels is that they inherently cause or create *too much* glare, posing a nuisance to sensitive receptors and a safety risk for pilots. In certain situations, the glass surfaces of solar PV systems can produce glint (a momentary flash of bright light) and glare (a reflection of bright light for a longer duration); however, light absorption, rather than reflection, is central to the function of a solar PV panel so that it may absorb solar radiation and convert it to electricity. Solar PV panels are constructed of dark-colored (usually blue or black) materials and are covered with anti-reflective coatings. Modern PV panels reflect as little as 2 percent of incoming sunlight, which is less than soil and wood shingles (Day and Mow 2018).

Despite their low potential to create glare, PV panels can reflect sunlight skyward toward the light source, creating a potential glare impact for aircraft in the area. The effect is similar to what a motorist experiences when the sun is low in the sky and the car passes between the sun and a glass-fronted building that has been treated with an anti-reflective coating. If the motorist is heading directly toward the building, the glare would shine in the motorist's eyes. Otherwise, the motorist would have to rotate his or her head to observe the glare off to the side. Because aircraft typically travel at a higher rate of speed than vehicles, the effect is momentary, lasting only if the angle between the sun, water body, and aircraft is maintained. Unless an aircraft were descending at an angle sloped directly at the solar array with the sun directly behind the aircraft, any glare that might occur from solar panels would be below the pilot's horizon.

4.0 IMPACT ASSESSMENT

4.1 Thresholds of Significance

Except as provided in Public Resources Code Section 21099, a project would be considered to have a significant impact if it would meet any of the following criteria:

1. Have a substantial adverse effect on a scenic vista?
2. Substantially damage scenic resources, including, but not limited to trees, rock outcroppings, and historic buildings within a state scenic highway?
3. Substantially degrade the existing visual character or quality of public views of the site and its surroundings? (Public views are those that are experienced from publicly accessible vantage point). If the Project is in an urbanized area, would the Project conflict with applicable zoning and other regulations governing scenic quality?
4. Create a new source of substantial light or glare, which would adversely affect day or nighttime views in the area?

4.2 Contrast Rating Analysis

As described in section 2.5, the sole KOP, KOP 1, was identified for the Proposed Project (Figures 1 and 2). The view from KOP 1 is that seen from Siphon 13 at an elevation bridge over the Coachella Canal, looking west, approximately 0.5 mile from the site. The view from KOP 1 is currently characterized by broad, panoramic views of flat, consistent, and horizontal terrain in the foreground, midground and background. The terrain is smooth and consistent, with fine smooth soils. Additionally, irregular lines from shrubs and light brown-dark soils are found throughout the area. As noted above in Section 3.3, the Proposed Project is not seen from KOP 1 except for the proposed gen-tie transmission line.

The changes that affect contrast when compared to the current environmental setting and as viewed at KOP 1 are:

- Landforms – Currently, various agricultural plots and associated buildings and other structures exist just south of the Project Site, and open space desert scrub exist in all other directions. The Proposed Project would add structures (i.e., solar arrays, BESS, 0.5-mile gen-tie line) in the foreground and midground. Except for the gen-tie line, structures are expected to not exceed 10 feet in height. Because only the proposed transmission gen-tie line would be visible from KOP 1, and there are existing transmission lines in the Project Area viewable from KOP 1, this would result in a weak change in contrast.
- Lines – Lines in the existing setting, to the north, east and west are currently defined by irregular broken shrubs and local road surfaces. New lines would be generated by the gen-tie line (i.e., transmission poles and sagging conductor wires). Addition of the new lines from the vertical lines by the transmission poles of the proposed gen-tie line and elevated lines from the conductor wires would be noticeable in foreground and midground. Because of the existing transmission structures and conductors seen from KOP 1, this would result in a weak change in contrast.
- Color – Light brown/dark brown soils, light tan-brown desert shrubs currently dominate the view. Because the gen-tie structures and conductors would be similar to those visible in the existing view, the change in color contrast at KOP 1.
- Texture – Current views from KOP 1 towards to Project site consist of smooth, consistent terrain with fine, smooth soils and smooth low laying clusters of shrubs. The Proposed Project would add transmission line structures and conductors similar to those already visible from KOP 1. Therefore, construction of the Proposed Project would result in a weak texture contrast from KOP 1 because existing transmission lines run throughout the general area.

Overall, the impact from the change in contrast from the Proposed Project would have a weak impact when viewed from KOP 1.

The completed contrast rating form is provided in Appendix A.

4.3 Solar Glare Analysis

The glare analysis shows that the Proposed Project is predicted to emit medium (yellow) glare with the potential for temporary after-image up to 995 minutes (16.6 hours) annually. Eight receptors were evaluated for annual potential glare from the Proposed Project, with two showing potential for glare. Two may experience glare. The first receptor, motorists traveling northwest on Wilkins Road, in the vicinity of the Proposed Project, may experience 156 minutes (2.6 hours) of medium glare between approximately 6:00 a.m. to 7:00 a.m. mid-February to mid-April and September to mid-December, when the modules are fully rotated to the east and west, respectively. The glare would be experienced as a momentary glint for motorists. The second receptor, at a stationary observation point just west of the midpoint of the western boundary of the Proposed Project, may experience up to 830 minutes (13.8 hours) between 5:00 a.m. and 7:00 a.m. throughout the year, when the modules are fully to the west. The duration is 0 to 5 minutes early and late in the year and up to 7 minutes in mid-year. This road is lightly traveled, and therefore glare exposure would be minimal.

Results of the solar glare modeling are provided in Appendix B.

4.4 Impact Analysis

1. Would the Project have a substantial adverse effect on a scenic vista?

There are no designated scenic vistas in the Proposed Project vicinity. Therefore, no impacts to scenic vistas would occur. No mitigation would be required.

2. Would the Project substantially damage scenic resources, including, but not limited to trees, rock outcroppings, and historic buildings within a state scenic highway?

There are no designated or eligible scenic highways in the Proposed Project vicinity. The Proposed Project would result in changes to the visual character (i.e., line, color, and texture) of the Proposed Project Site, which is currently characterized as desert landscape to the north, east and south and agricultural land to the south. The existing, natural landscape is a valued, important, beautiful, and scenic resource, including views of the Chocolate Mountains in the background. With the addition of structures (e.g., solar arrays, gen-tie line) to an area where there are currently none, the change in contrast in the foreground is strong. However, other than the proposed transmission gen-tie line that is visible from KOP 1, the Project site is generally not visible from nearby roads or residences, and therefore the contrast associated with the introduction of the proposed new line, which is similar to existing lines, is weak.

Impacts to sensitive receptors from the Proposed Project would be temporary or lessened because:

- Based on the results of the viewshed analysis, viewers generally cannot see the Proposed Project;
- The lifespan of the Proposed Project is 20 years, with full restoration after closure, addressing the change in contrast from the Proposed Project in the long-term.

- With the growing need to improve renewable resources, sensitive receptors are likely to consider the Proposed Project as an interesting technology to see, rather than objectionable.

This results in a less than significant impact. No mitigation would be required.

3. Would the Project substantially degrade the existing visual character or quality of public views of the site and its surroundings? (Public views are those that are experienced from publicly accessible vantage point). If the project is in an urbanized area, would the Project conflict with applicable zoning and other regulations governing scenic quality?

See discussion under Criterion 2. There are no public viewpoints in the Proposed Project Site and it is not in an urbanized area. Impacts under this criterion would be less than significant. No mitigation would be required.

4. Would the Project create a new source of substantial light or glare, which would adversely affect day or nighttime views in the area?

The Project would not include any substantial source of nighttime light in the vicinity of the Project Site. Any lighting required for safety and security within the Project Site would be hooded and oriented downward so as not to spill over into adjacent parcels.

As discussed in Section 4.3, the glare analysis for the Proposed Project concluded that glint that may be experienced by northeast-bound motorists on Wilkins Road. Motorists, which are not stationary receptors, may experience momentary glint for short periods between 6:00 a.m. and 7:00 a.m., early and late in the year. Receptors just west of the Proposed Project boundary may experience glare during those same times. Potential receptors nearby can be represented by agricultural workers conducting day-to-day activities. Workers may experience momentary and temporary glare while conducting their activities.

Given the brief period glare would be produced or experienced, and that few people would regularly experience glint or glare, these effects are considered less than significant. No mitigation is required.

4.5 Mitigation Measures

The analysis, in this section shows less than significant impact for the four criteria. Therefore, no mitigation measures are required.

5.0 REFERENCES

- Bureau of Land Management (BLM). 2018. Form 8400-4. Available online at: <https://www.blm.gov/sites/blm.gov/files/8400-004.pdf>. June.
- _____. 1986. *Manual 8431 – Visual Resource Contrast Rating*. January.
- California Department of Transportation (Caltrans). 2023. *California Scenic Highways*. Available online at: <https://maps.conservation.ca.gov/DLRP/CIFF/>.
- Imperial County. 2015. Imperial County General Plan *Renewable Energy and Transmission Element County of Imperial County*. Available online at: <https://www.icpds.com/planning/land-use-documents/general-plan>.
- Day, Megan and Benjamin Mow. 2018. *Research and Analysis Demonstrate the Lack of Impacts of Glare from Photovoltaic Modules*. July. Available online at: <https://www.nrel.gov/state-local-tribal/blog/posts/research-and-analysis-demonstrate-the-lack-of-impacts-of-glare-from-photovoltaic-modules.html>
- Department of Conservation. 2016. *Imperial County Important Farmland Map*. Available online at: <https://maps.conservation.ca.gov/DLRP/CIFF/>.
- Federal Aviation Administration. 2022. Technical Guidance for Evaluating Selected Solar Technologies on Airports. Available online at: <https://hmmh.com/projects/faa-technical-guidance-for-solar-technologies-on-airports/>
- Palmer, James F. English, Donald B.K. *An Index of Viewer Sensitivity to Scenery While Engaged in Recreation Activities on U.S. National Forests*. 2019. Available online at: <https://www.sciencedirect.com/science/article/pii/S0169204618306285?via%3Dihub>.

LIST OF APPENDICES

Appendix A – Contrast Rating Worksheets

Appendix B – Glare Analysis Report

APPENDIX A

Contrast Rating Worksheets

VISUAL CONTRAST RATING WORKSHEET NORTH STAR 1, KOP 1

Date: 2/07/2023

Project Name: North Star 1 SES and BESS	Key Observation Point Number: KOP1
Project Type: Solar Facility	Key Observation Point Name: Siphon 13
Evaluator's Names: Marilyn Blume	Photo Number: Figure 2

CHARACTERISTIC LANDSCAPE DESCRIPTION

	1. LAND/WATER	2. VEGETATION	3. STRUCTURES
FORM	Endless, broad, flat, vast open terrain; Coachella Canal	Sonoran Scrub	Coachella Canal
LINE	Irregular lines from shrubs throughout area; linear canal	Irregular, broken shrubs in foreground	Coachella Canal
COLOR	Light brown-dark brown soils; gray canal; blue water	Light brown/dark brown soils, light tan-brown desert shrubs	Coachella Canal
TEXTURE	Smooth, consistent terrain; fine, smooth soils; smooth, concrete-lined canal	Smooth, low laying clusters of shrubs	Coachella Canal

PROPOSED ACTIVITY DESCRIPTION

	1. LAND/WATER	2. VEGETATION	3. STRUCTURES
FORM	No perceived change	No perceived change	Thin, horizontal, regular edge for solar arrays Geometric isolation Rectangular battery storage Transmission interconnection
LINE	No perceived change	No perceived change	Horizontal line from solar array edge Horizontal and vertical lines from battery storage Horizontal line to transmission line
COLOR	No perceived change	No perceived change	Dark subdued grey to blue black solar arrays Light grey earthtones from battery storage Muted reflective grey transmission line
TEXTURE	No perceived change	No perceived change	Matte surfaces on solar arrays, BESS and gen-tie line

DEGREE OF CONTRAST		FEATURES											
		LAND/WATER BODY (1)				VEGETATION (2)				STRUCTURES (3)			
		Strong	Moderate	Weak	None	Strong	Moderate	Weak	None	Strong	Moderate	Weak	None
ELEMENTS	Form				X				X	X			
	Line				X				X		X		
	Color				X				X			X	
	Texture				X				X		X		

Recommended Mitigation Measures

Materials and surface treatments for structures and roads should repeat and/or blend with the existing form, line, color, and texture of the surrounding landscape. For example, if the project will be viewed against an earthen or other non-sky background, appropriately colored materials should be selected to help blend structures with the project’s backdrop.

Unless safety or functional requirements preclude it, all structures should be color treated to reduce contrasts with existing landscape.

Materials, coatings, or paints that have little or no reflectivity should be used on structures. Semi-gloss finishes should be used rather than flat or gloss finishes. Substation equipment should be specified with a low-reflectivity, neutral finish. Insulators at substations should be non-reflective. The surfaces of substation structures should be given low reflectivity finishes with neutral colors to minimize the contrast of the structures with their backdrops. Security fence surrounding the substations should have a dulled, darkened finish to reduce contrast.

Electric transmission towers should be color treated to reduce contrasts with the existing landscape. Monopole towers should have a low-reflectivity treatment. Where transmission facilities using monopole towers are located within the same ROW or corridor, the color treatment should match the existing facilities within the ROW, unless they contrast with the visual backdrop.

Notes

APPENDIX B

Glare Analysis Report

FORGESOLAR GLARE ANALYSIS

Project: Northstar #1

Proposed construction of a nominal 50 MW alternating current PV energy generation system, accompanied by a 75 MW battery storage, utilizing either thin film or crystalline solar PV technology modules mounted either on fixed frames or horizontal single-axis tracker (HSAT) systems.

Site configuration: **Northstar 1**

Client: ZGlobal

Created 29 Jul, 2022

Updated 09 Nov, 2022

Time-step 1 minute

Timezone offset UTC-8

Site ID 73350.12915

Category 10 MW to 100 MW

DNI peaks at 1,000.0 W/m²

Ocular transmission coefficient 0.5

Pupil diameter 0.002 m

Eye focal length 0.017 m

Sun subtended angle 9.3 mrad

Methodology V2

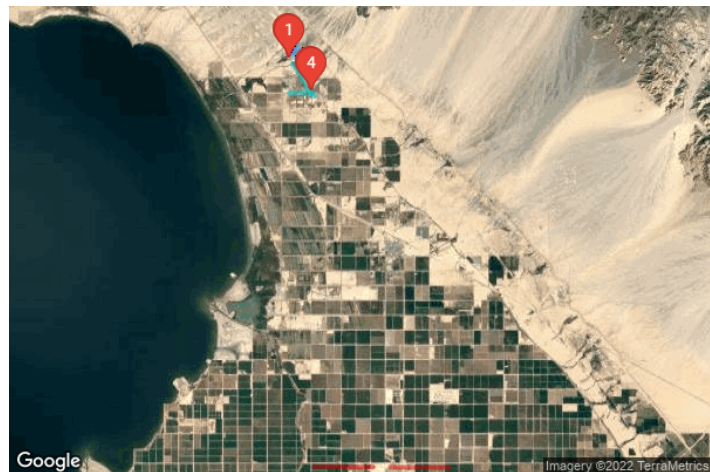

Summary of Results Glare with potential for temporary after-image predicted

PV Array	Tilt °	Orient °	Annual Green Glare		Annual Yellow Glare		Energy kWh
			min	hr	min	hr	
PV2	SA tracking	SA tracking	0	0.0	995	16.6	139,700,000.0

Total annual glare received by each receptor; may include duplicate times of glare from multiple reflective surfaces.

Receptor	Annual Green Glare		Annual Yellow Glare	
	min	hr	min	hr
Hobbs Road	0	0.0	0	0.0
Wilkins Road	0	0.0	156	2.6
Calpatría Airport - FP 26	0	0.0	0	0.0
Calpatría Airport - FP 8	0	0.0	0	0.0
OP 1	0	0.0	830	13.8
OP 2	0	0.0	9	0.1
OP 3	0	0.0	0	0.0
OP 4	0	0.0	0	0.0

Component Data

PV Arrays

Name: PV2
Axis tracking: Single-axis rotation
Backtracking: Shade-slope
Tracking axis orientation: 180.0°
Max tracking angle: 90.0°
Resting angle: 0.0°
Ground Coverage Ratio: 0.5
Rated power: 50000.0 kW
Panel material: Light textured glass without AR coating
Reflectivity: Vary with sun
Slope error: correlate with material



Vertex	Latitude (°)	Longitude (°)	Ground elevation (ft)	Height above ground (ft)	Total elevation (ft)
1	33.335827	-115.571441	-25.29	1.00	-24.29
2	33.335835	-115.564559	11.58	1.00	12.58
3	33.332455	-115.564553	-10.93	1.00	-9.93
4	33.332458	-115.562531	3.45	1.00	4.45
5	33.325753	-115.562519	-25.82	1.00	-24.82
6	33.325751	-115.564442	-36.20	1.00	-35.20
7	33.328542	-115.564447	-26.01	1.00	-25.01
8	33.328539	-115.566469	-34.25	1.00	-33.25
9	33.330255	-115.566472	-28.72	1.00	-27.72
10	33.330252	-115.568494	-38.35	1.00	-37.35
11	33.332505	-115.568498	-29.95	1.00	-28.95
12	33.332502	-115.570618	-38.72	1.00	-37.72
13	33.331914	-115.570617	-43.89	1.00	-42.89
14	33.331911	-115.572540	-57.19	1.00	-56.19
15	33.333038	-115.572543	-50.22	1.00	-49.22
16	33.333035	-115.574564	-60.73	1.00	-59.73
17	33.335955	-115.574579	-49.30	1.00	-48.30
18	33.335954	-115.575386	-57.20	1.00	-56.20
19	33.336492	-115.575387	-54.22	1.00	-53.22
20	33.336489	-115.577409	-67.19	1.00	-66.19
21	33.339276	-115.577414	-47.57	1.00	-46.57
22	33.339284	-115.571447	-11.73	1.00	-10.73

Route Receptors

Name: Hobbs Road
Path type: Two-way
Observer view angle: 50.0°



Vertex	Latitude (°)	Longitude (°)	Ground elevation (ft)	Height above ground (ft)	Total elevation (ft)
1	33.314496	-115.562949	-67.38	0.00	-67.38
2	33.314505	-115.575394	-119.82	0.00	-119.82

Name: Wilkins Road
Path type: Two-way
Observer view angle: 50.0°



Vertex	Latitude (°)	Longitude (°)	Ground elevation (ft)	Height above ground (ft)	Total elevation (ft)
1	33.313258	-115.561027	-66.32	0.00	-66.32
2	33.314236	-115.562197	-65.45	0.00	-65.45
3	33.314487	-115.562486	-65.69	0.00	-65.69
4	33.314540	-115.562808	-67.48	0.00	-67.48
5	33.315885	-115.564096	-70.03	0.00	-70.03
6	33.319821	-115.567207	-68.03	0.00	-68.03
7	33.321139	-115.568098	-67.61	0.00	-67.61
8	33.322493	-115.568559	-69.17	0.00	-69.17
9	33.322977	-115.568774	-69.51	0.00	-69.51
10	33.326697	-115.571649	-68.73	0.00	-68.73
11	33.327209	-115.572129	-68.57	0.00	-68.57
12	33.328393	-115.572998	-69.81	0.00	-69.81
13	33.328877	-115.573523	-71.55	0.00	-71.55

Flight Path Receptors

Name: Calpatria Airport - FP 26

Description:

Threshold height: 50 ft

Direction: 270.3°

Glide slope: 3.0°

Pilot view restricted? Yes

Vertical view: 30.0°

Azimuthal view: 50.0°



Point	Latitude (°)	Longitude (°)	Ground elevation (ft)	Height above ground (ft)	Total elevation (ft)
Threshold	33.131288	-115.516448	-182.17	50.00	-132.17
Two-mile	33.131141	-115.481882	-164.62	585.87	421.25

Name: Calpatria Airport - FP 8

Description:

Threshold height: 50 ft

Direction: 90.4°

Glide slope: 3.0°

Pilot view restricted? Yes

Vertical view: 30.0°

Azimuthal view: 50.0°



Point	Latitude (°)	Longitude (°)	Ground elevation (ft)	Height above ground (ft)	Total elevation (ft)
Threshold	33.131397	-115.526582	-186.65	50.00	-136.65
Two-mile	33.131573	-115.561148	-197.69	614.46	416.77

Discrete Observation Point Receptors

Name	ID	Latitude (°)	Longitude (°)	Elevation (ft)	Height (ft)
OP 1	1	33.331680	-115.575638	-73.15	0.00
OP 2	2	33.332310	-115.576028	-68.21	0.00
OP 3	3	33.315900	-115.563135	-60.31	0.00
OP 4	4	33.315510	-115.562642	-59.80	0.00

Glare Analysis Results

Summary of Results Glare with potential for temporary after-image predicted

PV Array	Tilt	Orient	Annual Green Glare		Annual Yellow Glare		Energy
	°	°	min	hr	min	hr	kWh
PV2	SA tracking	SA tracking	0	0.0	995	16.6	139,700,000.0

Total annual glare received by each receptor; may include duplicate times of glare from multiple reflective surfaces.

Receptor	Annual Green Glare		Annual Yellow Glare	
	min	hr	min	hr
Hobbs Road	0	0.0	0	0.0
Wilkins Road	0	0.0	156	2.6
Calpatría Airport - FP 26	0	0.0	0	0.0
Calpatría Airport - FP 8	0	0.0	0	0.0
OP 1	0	0.0	830	13.8
OP 2	0	0.0	9	0.1
OP 3	0	0.0	0	0.0
OP 4	0	0.0	0	0.0

PV: PV2 potential temporary after-image

Receptor results ordered by category of glare

Receptor	Annual Green Glare		Annual Yellow Glare	
	min	hr	min	hr
Wilkins Road	0	0.0	156	2.6
Hobbs Road	0	0.0	0	0.0
Calpatría Airport - FP 26	0	0.0	0	0.0
Calpatría Airport - FP 8	0	0.0	0	0.0
OP 1	0	0.0	830	13.8
OP 2	0	0.0	9	0.1
OP 3	0	0.0	0	0.0
OP 4	0	0.0	0	0.0

PV2 and Wilkins Road

Receptor type: Route
 156 minutes of yellow glare
 0 minutes of green glare

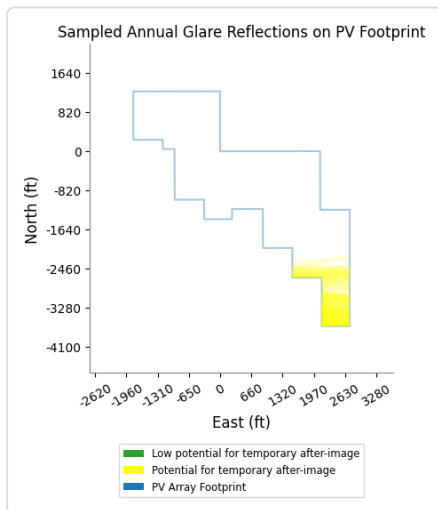
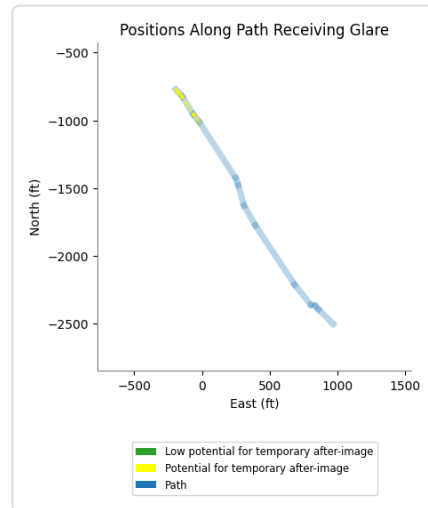
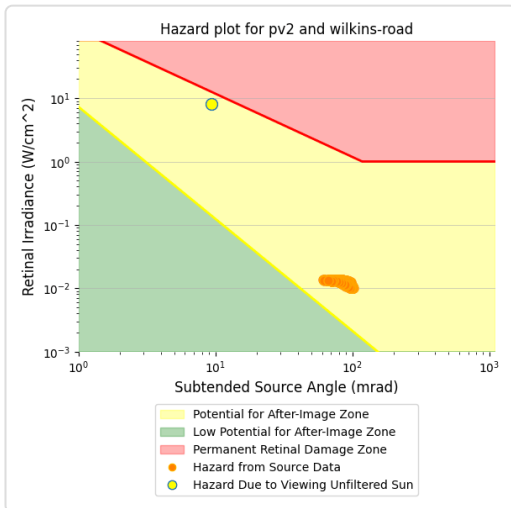
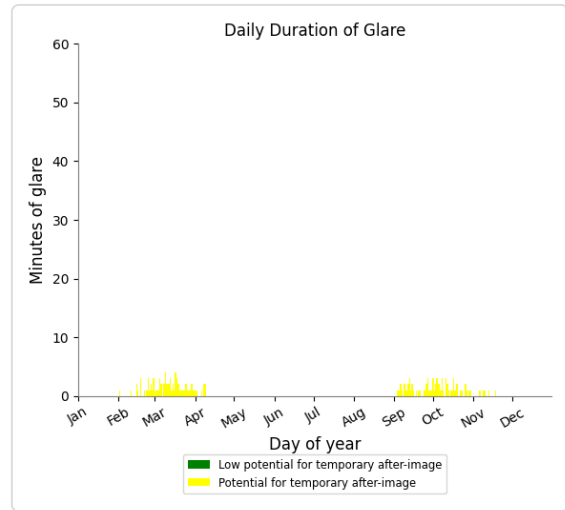
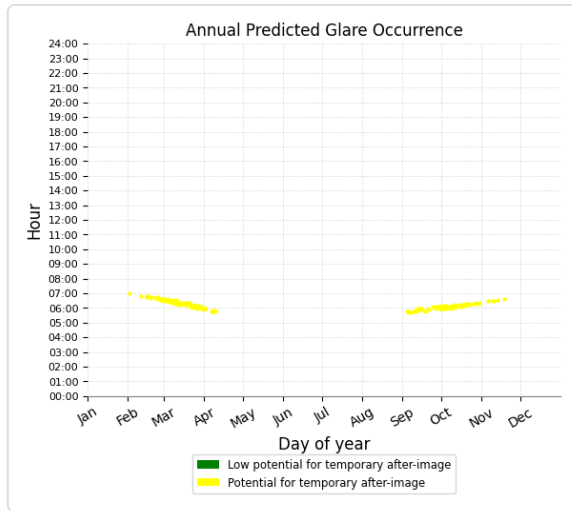

PV2 and Hobbs Road

Receptor type: Route
 No glare found

PV2 and Calpatria Airport - FP

26

Receptor type: 2-mile Flight Path
 No glare found

PV2 and Calpatria Airport - FP

8

Receptor type: 2-mile Flight Path
 No glare found

PV2 and OP 1

Receptor type: Observation Point
 830 minutes of yellow glare
 0 minutes of green glare

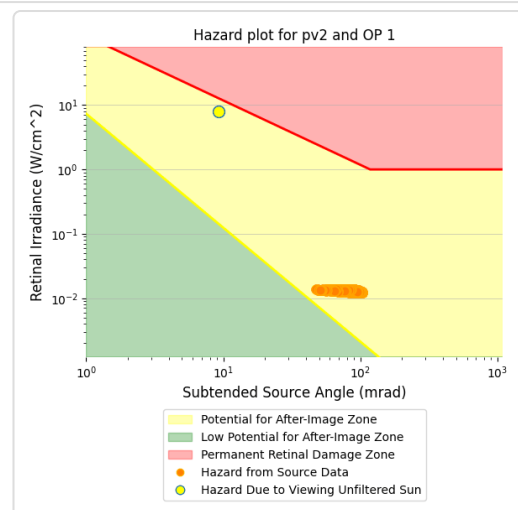
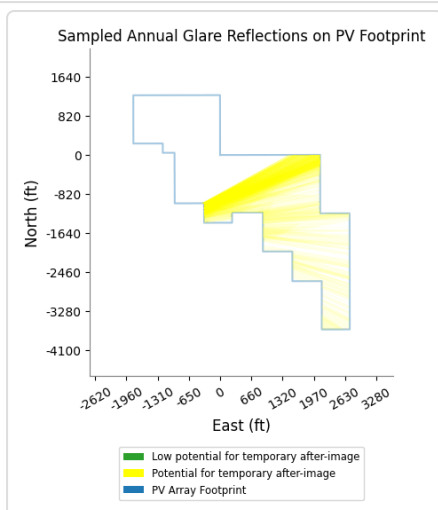
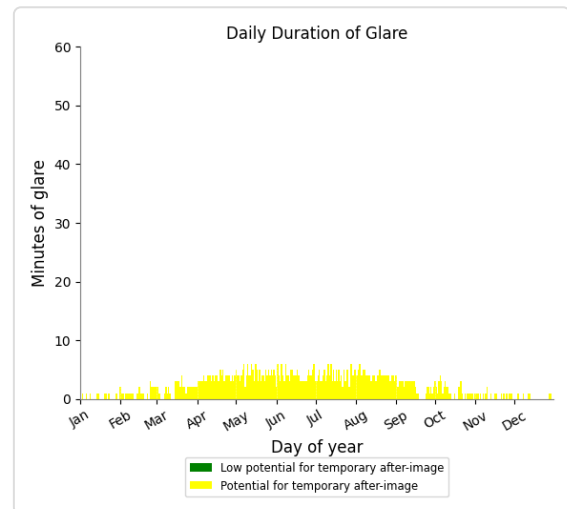
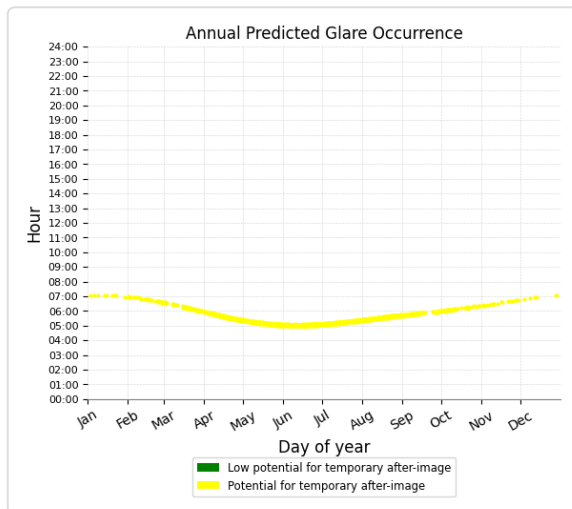

PV2 and OP 2

Receptor type: Observation Point

9 minutes of yellow glare

0 minutes of green glare

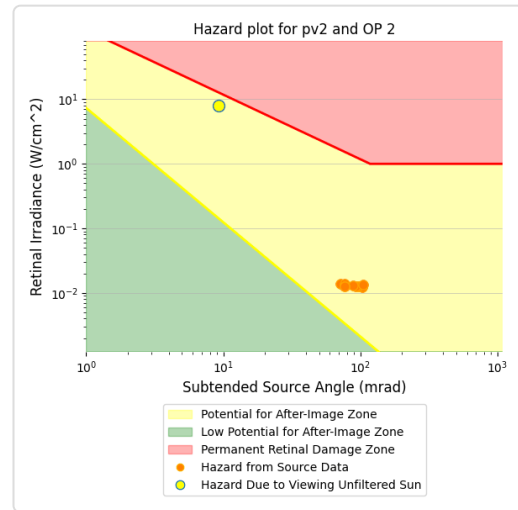
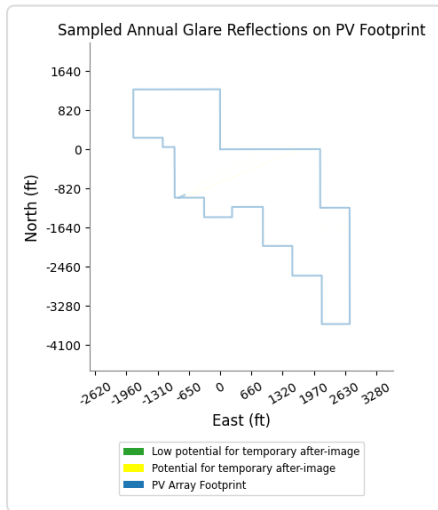
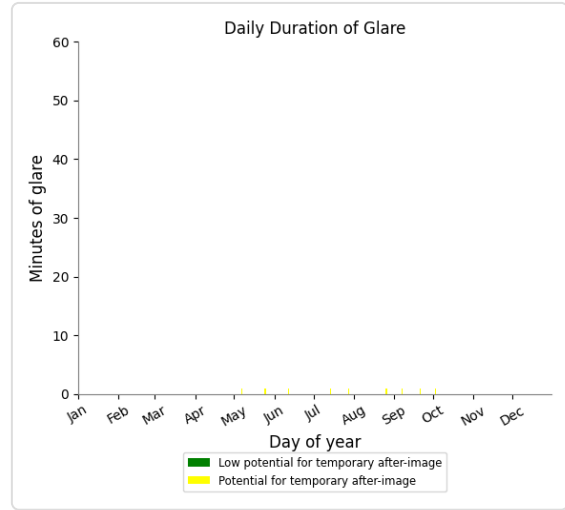
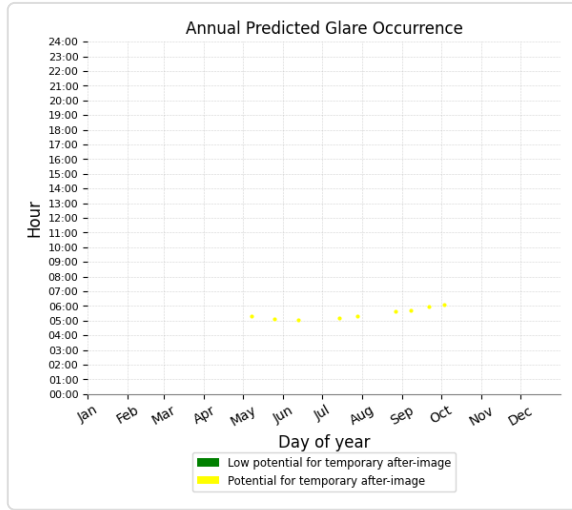

PV2 and OP 3

Receptor type: Observation Point

No glare found

PV2 and OP 4

Receptor type: Observation Point

No glare found

Assumptions

"Green" glare is glare with low potential to cause an after-image (flash blindness) when observed prior to a typical blink response time.

"Yellow" glare is glare with potential to cause an after-image (flash blindness) when observed prior to a typical blink response time.

Times associated with glare are denoted in Standard time. For Daylight Savings, add one hour.

The algorithm does not rigorously represent the detailed geometry of a system; detailed features such as gaps between modules, variable height of the PV array, and support structures may impact actual glare results. However, we have validated our models against several systems, including a PV array causing glare to the air-traffic control tower at Manchester-Boston Regional Airport and several sites in Albuquerque, and the tool accurately predicted the occurrence and intensity of glare at different times and days of the year.

Several V1 calculations utilize the PV array centroid, rather than the actual glare spot location, due to algorithm limitations. This may affect results for large PV footprints. Additional analyses of array sub-sections can provide additional information on expected glare. This primarily affects V1 analyses of path receptors.

Random number computations are utilized by various steps of the annual hazard analysis algorithm. Predicted minutes of glare can vary between runs as a result. This limitation primarily affects analyses of Observation Point receptors, including ATCTs. Note that the SGHAT/ ForgeSolar methodology has always relied on an analytical, qualitative approach to accurately determine the overall hazard (i.e. green vs. yellow) of expected glare on an annual basis.

The analysis does not automatically consider obstacles (either man-made or natural) between the observation points and the prescribed solar installation that may obstruct observed glare, such as trees, hills, buildings, etc.

The subtended source angle (glare spot size) is constrained by the PV array footprint size. Partitioning large arrays into smaller sections will reduce the maximum potential subtended angle, potentially impacting results if actual glare spots are larger than the sub-array size. Additional analyses of the combined area of adjacent sub-arrays can provide more information on potential glare hazards. (See previous point on related limitations.)

The variable direct normal irradiance (DNI) feature (if selected) scales the user-prescribed peak DNI using a typical clear-day irradiance profile. This profile has a lower DNI in the mornings and evenings and a maximum at solar noon. The scaling uses a clear-day irradiance profile based on a normalized time relative to sunrise, solar noon, and sunset, which are prescribed by a sun-position algorithm and the latitude and longitude obtained from Google maps. The actual DNI on any given day can be affected by cloud cover, atmospheric attenuation, and other environmental factors.

The ocular hazard predicted by the tool depends on a number of environmental, optical, and human factors, which can be uncertain. We provide input fields and typical ranges of values for these factors so that the user can vary these parameters to see if they have an impact on the results. The speed of SGHAT allows expedited sensitivity and parametric analyses.

The system output calculation is a DNI-based approximation that assumes clear, sunny skies year-round. It should not be used in place of more rigorous modeling methods.

Hazard zone boundaries shown in the Glare Hazard plot are an approximation and visual aid based on aggregated research data. Actual ocular impact outcomes encompass a continuous, not discrete, spectrum.

Glare locations displayed on receptor plots are approximate. Actual glare-spot locations may differ.

Refer to the Help page at www.forgesolar.com/help/ for assumptions and limitations not listed here.

Default glare analysis parameters and observer eye characteristics (for reference only):

- Analysis time interval: 1 minute
- Ocular transmission coefficient: 0.5
- Pupil diameter: 0.002 meters
- Eye focal length: 0.017 meters
- Sun subtended angle: 9.3 milliradians

2016 © Sims Industries d/b/a ForgeSolar, All Rights Reserved.

